

INDUSTRIAL UV SYSTEMS

# Avant™ Series

State-of-the-art UV Water Treatment System for Industrial Applications





### Improved Performance

Treats up to three-times more flow compared to our prior systems making it ideal for facilities of any size.



### Compact Footprint

Smaller system footprint compared to our previous systems, lowering installation costs and maintenance expenses.



### User-friendly Operator Interface

Intuitive interface enables at-a-glance system status checks. Avant makes the job easier for engineers and plant operators.



### Predictive Diagnostics

Our system controls offer advanced lamp power control, remote monitoring, and enhanced diagnostic capabilities to enable proactive maintenance that protects equipment, reduces costs & minimizes downtime.



#### Key Markets & Applications:

Food & Beverage (including liquid sugar treatment)	TOC Reduction
Life Sciences	Microbiological Inactivation
Microelectronics	Ozone Reduction
	Chlorine & Chloramine Reduction

## Reduce Total Cost of Ownership and Simplify Operation and Maintenance

The Avant series incorporates the latest innovations in UV technology and best-in-class components to reduce total cost of ownership and drastically simplify operation and maintenance.

This highly advanced product line utilizes UV technology to break down trace chemicals such as total organic carbon (TOC), chlorine & chloramines and ozone while also providing microbiological inactivation.

Our skid-mounted design allows for compact and flexible installation options with the ability to mount up to six chambers.

Efficient low-pressure high-output (LPHO) lamp technology significantly cuts down on the energy needed to treat your flow rate. And fewer lamps are needed to treat the same flow compared to previous generations of our products. This provides significant savings in energy and maintenance expenses.

Our control system allows you to monitor and adjust system functions from a remote location if desired. The system's diagnostic capabilities keep you ahead of unplanned failures to maximize uptime. Lamp power can be set to optimize electrical consumption while also ensuring treatment targets are being met.

### Ultraviolet (UV) light is a versatile, reliable approach to address numerous requirements in industrial water applications

#### UV for TOC Reduction

UV is used for the effective reduction of organics, commonly referred to as TOC (total organic carbon). Reduction of TOC is accomplished by incorporating a 185 nm UV system, appropriately designed and sized, as well as strategically located in conjunction with other equipment. Carbon dioxide is a typical by-product of a TOC reduction process, resulting in a drop in the resistivity of water.

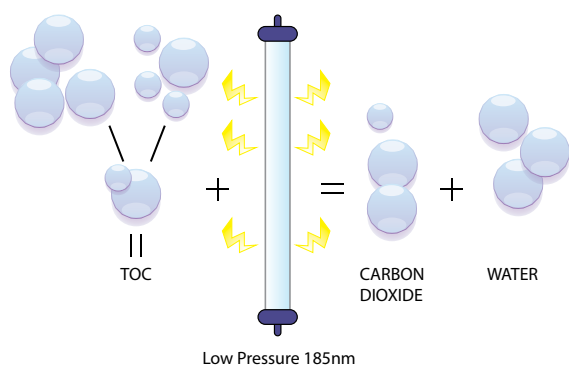

*UV light promotes the formation of free radicals leading to the oxidation of organics into CO<sub>2</sub> (carbon) and H<sub>2</sub>O (water) molecules.*

While most organic molecules are oxidized into carbon dioxide and water molecules, other more resistant species become weakly ionized or charged, after absorbing the UV. This is why polishing deionization (DI) beds are typically placed downstream of the TOC reduction units, so that they not only remove the charged/ionized organics, but also restore the resistivity to the water.

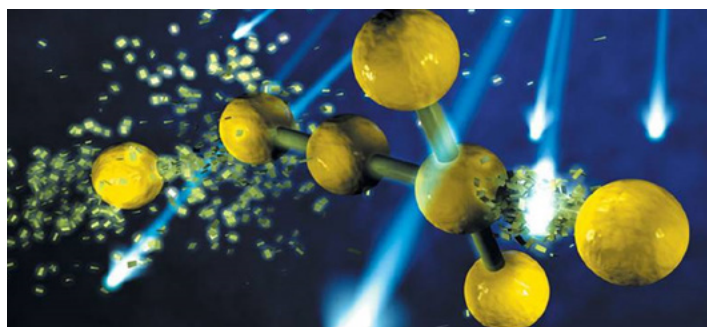

*UV breaks down the bonds of chlorine & chloramine molecules to reduce their levels down to parts per billion.*

#### UV for Microbial Inactivation

There are multiple locations throughout an industrial facility where UV can be installed to prevent microbial growth. Some typical locations would be post-carbon filter, pre-membrane filtration or RO (reverse osmosis), and pre-storage tanks. UV wavelengths inactivate microorganisms by damaging their DNA and instantaneously rendering them incapable of reproducing. The speed and efficiency of the treatment process allow the footprint of UV systems to be relatively small with no need for storage or contact tanks. The UV inactivation process adds nothing to the water but UV light, and therefore does not impact the taste, odor, or color of water.

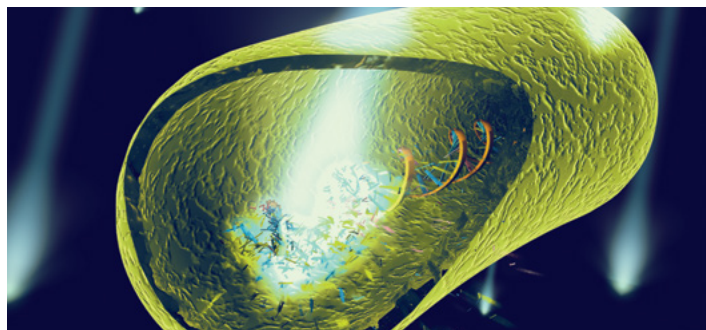

*UV light attacks the microorganisms genetic material (DNA) preventing replication.*

#### UV for Chlorine & Chloramines Reduction

Municipalities are required to add a residual to drinking water to ensure the control of microorganisms in their distribution lines. While this is a critical step for municipalities, it can cause an extra pre-treatment step for industrial facilities. If left in the incoming facility water, chlorine & chloramine can potentially damage metal piping, membrane filters, RO systems and degrade rubber, such as o-rings, gaskets or seals. Popular methods of removal, such as carbon beds or chemical injection, have proven to be problematic. Sodium metabisulfite involves replacing one chemical with another and creates food for microorganisms, while carbon beds can be inefficient, vulnerable to channeling, and provide breeding grounds for microorganisms. UV solves these problems while reducing chlorine & chloramines, using a small footprint, and reducing maintenance costs.



## System Design

### State-of-the-art UV water treatment system for Industrial applications

#### Programmable Logic Controller (PLC)

The controller continuously monitors and controls UV system functions including safety conditions. Off-spec conditions will generate critical and non-critical alarms.

An intuitive 7" touch-screen HMI allows the operator to configure various settings with ease. The easy-to-navigate HMI screen displays the status of individual lamps including detailed diagnostics.

#### Configurable Inlet/Outlet

Water can flow in either direction allowing the units to adapt to customer's piping requirements.

#### UV Intensity Sensor\*

UV intensity (UVI) sensors continuously monitor UV lamp output to ensure specified dose levels are maintained.

We offer a unique sensor for fluids with low ultraviolet transmittance, such as liquid sugar in food & beverage applications. This low UVI sensor is mounted in the center of the chamber for a 360 degree view of the lamp output from the entire array of lamps in the chamber.

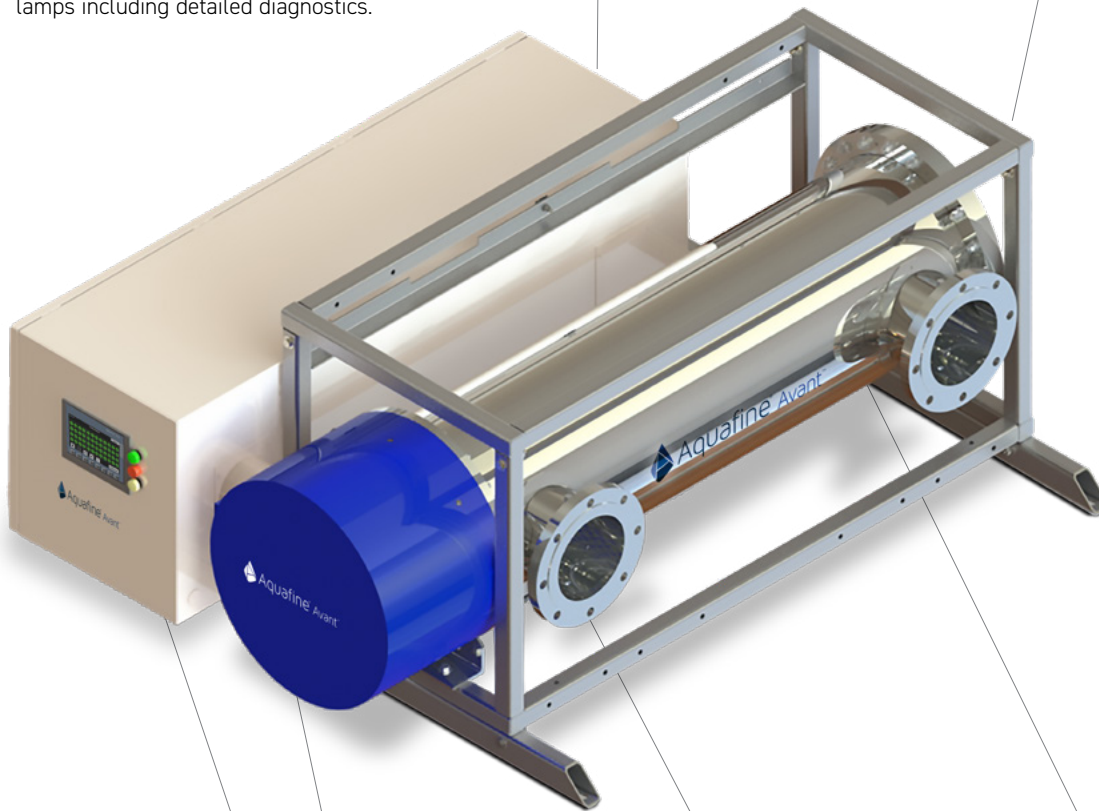

#### Inlet-Outlet Options

The Avant Series can be manufactured with either standard ANSI inlet-out flanges, or with tri-clamp sanitary connections.

Tri-clamps comply with the Food Contact Materials regulation that ensures wetted parts materials are appropriate for food contact.



#### Panel Enclosure

The painted carbon steel variant is a Type 1/IP51 panel. The panels are available in skid-mounted or stand-alone variations.

Stand-alone panels can be upgraded to Type 12/IP54 or a stainless-steel Type 4X/IP56 version.

#### End Cap

The end cap protects and isolates connections for components such as lamps and sleeves. Power is automatically disconnected if the end cap is removed thereby ensuring a safe working environment for operators.

#### UV Chamber

Electropolished 316L stainless steel chamber to fit into existing piping galleries or tight spaces.

#### Lamps

High efficiency, high output lamps are energy efficient, to provide superior system performance, and save operating costs due to reduced electric consumption. Single ended lamps are located within protective quartz sleeves with easy access from the service entrance.

\* Part of upgrade package

## Efficient LPHO Lamp Technology

Our efficient low-pressure high-output (LPHO) lamp technology significantly cuts down on the energy needed to treat your flow rate. Fewer lamps are now needed to treat the same flow compared to previous generations of our products. This allows plants to significantly save on power expenditures, lamp replacement costs, and maintenance expenses.

Avant met the same performance level to reduce TOC levels below 2 ppb with significantly lower power consumption.

	SCD-H	Avant
Unit Quantity	8	3
Annual Power Consumption	531,050 KW	209,121 KW

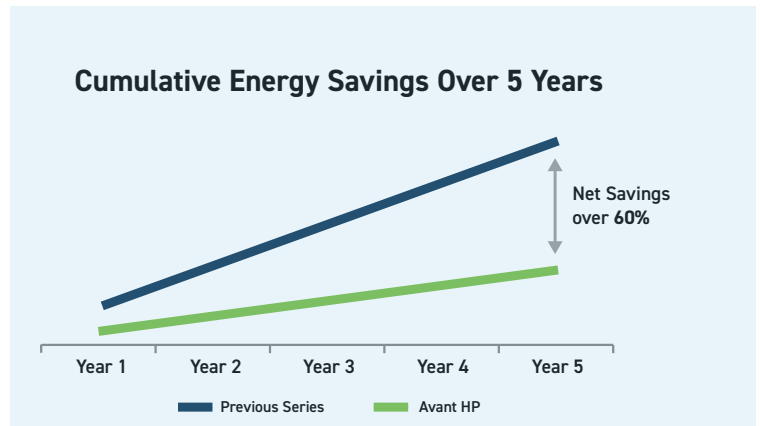

## Aquafine® Colorguard® UV Lamps

All of our Aquafine systems come with best-in-class Aquafine Colorguard™ UV lamps.

Colorguard lamps are operating reliably in over 100,000 systems, in a range of applications, around the world. The Colorguard system makes it easy for team members responsible for ordering and replacing UV lamps to identify which lamps are needed where.

Lamps undergo a rigorous quality control inspection and testing program to ensure efficient operation and reliable performance over the life of the lamp.



**High Energy Savings**

**Lower Lamp Replacement Costs**

**Easy Maintenance**

**Proven Core Components**

## State-of-the-Art Controls and Predictive Maintenance

User friendly operator interface with touch screen for easy operation, monitoring and troubleshooting

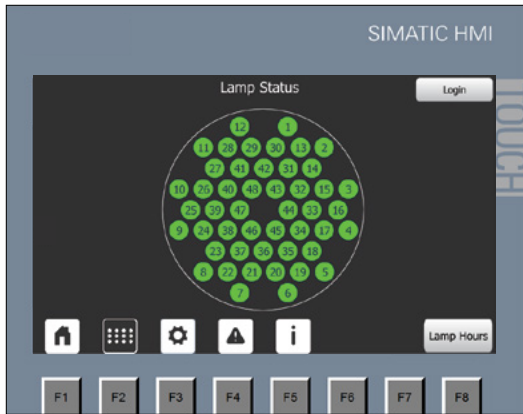

### Advanced Lamp Control

The system can be operated in three modes; 100% On, Manual Dimming and Grouping. The Grouping mode allows a set number of lamps to be turned off, allowing treatment to be optimized under changing conditions. This enhanced power control allows operators to meet their treatment targets while minimizing their electrical consumption and operating expenses.

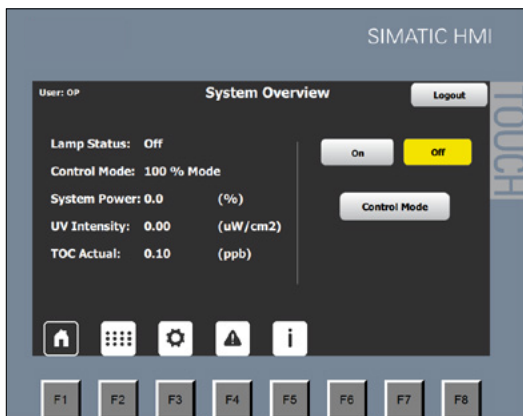

### Predictive Maintenance Tool & Smart Driver Technology

Our predictive maintenance tool and smart driver technology enhance diagnostic capabilities to enable proactive maintenance that protects equipment, reduces costs & minimizes downtime.

The predictive maintenance tool monitors the health of individual lamps so you can proactively change lamps before a failure. It also monitors for any unusual power consumption or operating patterns. Smart driver technology monitors individual lamp drivers. It can recognize a lamp failure, preventing the driver from being damaged by trying to turn on a lamp that is no longer operational.

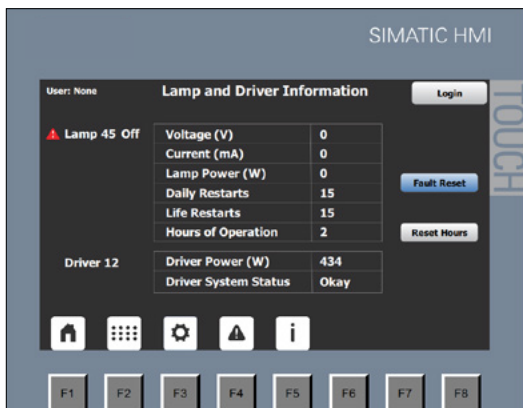

### Remote System Monitoring

Communication protocols included in the base models enable users to continuously monitor all available system information from a remote location, which reduces operational expenses and allows for immediate action if an issue arises.

## Avant High Performance (HP) Model For UPW Plants

**Our HP Avant system is designed specifically for UPW facilities so they can reclaim plant footprint while treating more flow**

Avant HP is a cutting edge TOC reduction system that provides improved performance and reduced costs. Compared to our previous offerings, Avant HP can save up to 75% in footprint while treating more flow. The reduction in UV units not only helps to save in upfront capital & installation investments, but also significantly reduces future maintenance expenses.

The modular skid configuration allows multiple units to be stacked, taking advantage of Aquafine's technology in a compact and easily expandable footprint. Special grade synthetic quartz sleeves allow more UV light to pass through to improve treatment performance & efficiency.

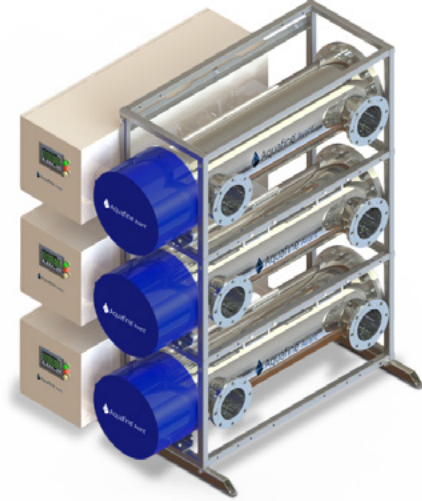

### Footprint of the Avant HP Compared to Previous Offering

#### 8 X SCD-H

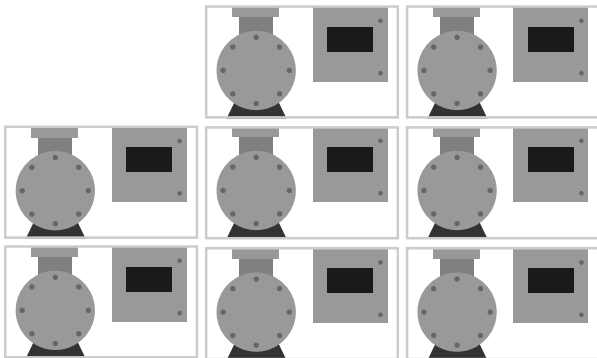

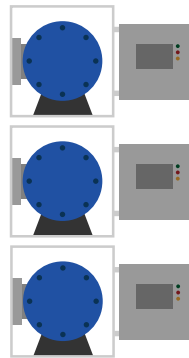

#### 3 X Avant HP



**Up to 75%  
Footprint Savings!**



# AVANT SERIES | TOC REDUCTION

MODEL NAME	Avant 20		Avant 36		Avant 44		Avant 48	
<b>Lamps</b>								
185nm	Standard							
Lamp Power	155 W							
Quartz Material	Avant		Natural					
	Avant HP		Synthetic					
Number of UV Lamps	20		36		44		48	
Lamp Type	Low Pressure High Output							
<b>Flow Rate</b>								
Maximum Hydraulic Flow gpm (m <sup>3</sup> /hr)	386 (87.6)		867 (196.9)		867 (196.9)		1500 (340.6)	
Minimum Hydraulic Flow gpm (m <sup>3</sup> /hr) at 25°C	1.5 (0.36)		2.4 (0.54)		2.9 (0.66)		3.2 (0.73)	
For Application Specific Sizing, please contact Trojan Technologies								
<b>Treatment Chamber</b>								
Chamber Length Inches (mm) <sup>1</sup>	79 (2006)							
Chamber Diameter Inches (mm)	12 (305)		14 (356)		16 (406)		18 (457)	
Standard I/O Size Inches (mm)	4 (101)		6 (152)		6 (152)		8 (203)	
I/O Type	Standard: ANSI Custom: Sanitary							
Pressure Rating	Up to 150 psi [PN10]							
<b>Electrical Requirements</b>								
Electrical Supply	System Power (kVA)	System Current (A)	System Power (kVA)	System Current (A)	System Power (kVA)	System Current (A)	System Power (kVA)	System Current (A)
208Vac, 3PH, 50/60Hz 3W + GND	3.9	12	6.8	19	8.3	24	9	25
220-240Vac, 1PH, 50/60Hz, 2W + GND	3.9	18	6.9	31	8.3	38	9	41
240Vac, 3PH, 50/60Hz, 3W + GND	4	11	6.9	17	8.3	21	9.1	22
380/220Vac, 3PH, 50Hz, 4W + GND	3.9	7	6.9	11	8.3	13	9	15
400/230Vac, 3PH, 50Hz, 4W + GND	3.9	6	6.9	11	8.3	13	9.1	14
415/240Vac, 3PH, 50Hz, 4W + GND	4	6	6.9	10	8.3	12	9.1	14
440Vac, 3PH, 50/60Hz, DELTA	4	7	6.9	12	8.3	15	9.1	16
480/277Vac, 3PH, 60Hz, 4W + GND	4.3	6	7.2	9	8.7	12	9.4	12
<b>Control Power Panel - Modular (Standard)</b>								
Material & Rating	Standard: Painted Carbon Steel ( TYPE 1 - IP 51)							
Dimensions H×W×D Inches (cm)	23 × 66 × 23 (59 × 168 × 59)							
<b>Control Power Panel - Stand Alone (Optional)</b>								
<b>Standard</b>								
Material and Coating	Painted Carbon Steel (UL or CE TYPE 12 - IP 54)							
Cooling	Forced Air and Vent							
Installation Location	Indoor Only							
Conduit Length	9 feet							
<b>Optional</b>								
Material and Coating	304 Stainless Steel (UL or CE Type 4X - IP 56)							
Cooling	Forced Air and Vent, With Shroud							
Installation Location	Indoor Only							
Conduit Length	15 feet							
Dimensions H×W×D Inches (cm)	65 × 35 × 19 (166 × 90 × 50)							
Certifications	  							

NOTES: Dimensions are for informational purposes only and not to be used for design. Refer to system layout drawings.  
1. Overall Length with End Cap Installed



# AVANT SERIES | LIQUID SUGAR

MODEL NAME	Avant 20		Avant 36		Avant 44	
<b>Maximum Flow Rate</b>						
Flow Rate (gpm)*	345 gpm - 728 gpm					
Flow Rate (m <sup>3</sup> /hr)*	78 m <sup>3</sup> /hr - 165 m <sup>3</sup> /hr					
Minimum Cooling Flow Rate gpm (m <sup>3</sup> /hr) @25°C	1.5 (0.36)		2.4 (0.54)		2.9 (0.66)	
Number of UV Lamps	20		36		44	
For Application Specific Sizing, please contact Trojan Technologies						
<b>Operating Conditions</b>						
Fluid operating temperature °F (°C)	34° - 131° (1° - 55°)					
UV Transmittance Range	20% - 50% UVT					
Maximum Operating Pressure PSI (BAR)	150 (10)					
Hot Water Sanitization °F (°C)	194° (90°)					
<b>Electrical Requirements</b>						
Electrical Supply	System Power (kVA)	System Current (A)	System Power (kVA)	System Current (A)	System Power (kVA)	System Current (A)
208Vac, 3PH, 50/60Hz 3W + GND	3.9	12	6.8	19	8.3	24
220-240Vac, 1PH, 50/60Hz, 2W + GND	3.9	18	6.9	31	8.3	38
240Vac, 3PH, 50/60HZ, 3W + GND	4	11	6.9	17	8.3	21
380/220Vac, 3PH, 50Hz, 4W + GND	3.9	7	6.9	11	8.3	13
400/230Vac, 3PH, 50Hz, 4W + GND	3.9	6	6.9	11	8.3	13
415/240Vac, 3PH, 50Hz, 4W + GND	4	6	6.9	10	8.3	12
440Vac, 3PH, 50/60Hz, DELTA	4	7	6.9	12	8.3	15
480/277Vac, 3PH, 60Hz, 4W + GND	4.3	6	7.2	9	8.7	12
<b>Chamber</b>						
Material of Construction	316L Stainless Steel					
Chamber Length - in (mm) <sup>1</sup>	79 (200.6)					
Chamber Diameter - in (cm)	12 (30.5)		14 (35.6)		16 (40.6)	
I/O Sanitary Tri-clamp size - in (cm)	4 (10)		6 (15)		6 (15)	
Surface Finish	Ra15					
Elastomers	EPDM (EC1935/2004, FDA)					
<b>Monitoring and Controls</b>						
<b>Standard</b>	Base Package: Lamp status indicator, System hours of operation, Lamp out alert (LOA) and Remote start/stop (HOA)					
<b>Optional</b>	UV Monitoring Package: UV intensity reading with NIST certified sensor, theoretical dose display					
<b>Control Panel - Modular (Standard)</b>						
Material of Construction	Painted Carbon Steel					
Rating	UL Type 1 (IP51) with Forced Air and Vent					
Dimensions H×W×D - in (cm)	23 × 66 × 23 (59 × 168 × 59)					
Installation Location	Indoor Only					
Operating Temp Ambient °F (°C)	34° - 104° (1° - 40°)					
<b>Control Panel - Stand Alone (Optional)</b>						
<b>Standard</b>						
Material of Construction	Painted Carbon Steel					
Rating	UL Type 12 (IP 54) with Forced Air and Vent					
Installation Location	Indoor Only					
Conduit Length	9 feet					
Operating Temp Ambient °F (°C)	34° - 104° (1° - 40°)					
<b>Optional</b>						
Material of Construction	304 Stainless Steel					
Rating	UL Type 4X (IP56) Forced Air and Vent, With Shroud					
Installation Location	Indoor Only					
Conduit Length	15 feet					
Operating Temp Ambient °F (°C)	34° - 104° (1° - 40°)					
Dimensions H×W×D Inches (cm)	65 × 35 × 19 (166 × 90 × 50)					
Certifications	  					

NOTES: Dimensions are for informational purposes only and not to be used for design. Refer to system layout drawings.

<sup>1</sup> Overall Length with End Cap Installed

\* Dose Level: 50 mJ/cm<sup>2</sup> after 9,000 hours of operation @ 50% UVT

## Aquafine Performance Guarantee and Regional Support

Aquafine provides a Lifetime Performance Guarantee for its UV products. A Lifetime Performance Guarantee means that the UV system will achieve the targets for which it was designed and sized on the original sales order of the equipment which considers operational parameters such as UVT of the fluid, maximum flow rate, operating pressure, fluid temperature, among others.

The Lifetime Performance Guarantee will only be applicable with the use of genuine OEM replacement parts. This guarantee is valid for the life of the equipment and it is available for both new and existing equipment when applicable conditions are met.

Our extensive network of local certified service providers offer fast response for service and spare parts.

Customer support is available from our Authorized Distributor Network and from our Technical Assistance Centre Monday to Friday, 8:00 a.m. to 5:00 p.m. (EST). After hours emergency support is available 24/7.

For questions regarding your application needs, please contact your local Authorized Distributor or Trojan Technologies for more information.



To learn more about the brands and affiliates of Trojan Technologies, please visit [www.trojantechnologies.com](http://www.trojantechnologies.com)

