



DOC326.97.00102

# **Professional Boiler/Cooling Water Test Kit**

**PBC-DT (2350700)**

01/2018, Edition 1

**User Manual**



<b>General information</b> .....	3
Safety information .....	3
Use of hazard information .....	3
Product overview .....	3
Product components .....	5
<b>Alkalinity</b> .....	6
Test preparation .....	6
Sample collection .....	6
Test procedure—Alkalinity (mg/L as CaCO <sub>3</sub> ) .....	7
Sample volumes and digit multipliers .....	8
Alkalinity pH endpoints .....	8
Determine the alkalinity relationships .....	9
Interferences .....	9
Clean the pH probes .....	10
Replacement items .....	10
Optional items .....	10
<b>Chloride</b> .....	12
Test preparation .....	12
Test procedure—Chloride (mg/L Cl <sup>-</sup> ) .....	12
Sample volumes and digit multipliers .....	13
Interferences .....	14
Replacement items .....	14
Optional items .....	14
<b>Total Chlorine</b> .....	16
Test preparation .....	16
Test procedure—Total chlorine (0–3.4 mg/L Cl <sub>2</sub> ) .....	16
Interferences .....	17
Replacement items .....	17
Optional items .....	17
<b>Hardness, Total</b> .....	19
Test preparation .....	19
Sample collection and storage .....	19
Test procedure—Hardness (mg/L CaCO <sub>3</sub> ) .....	20
Sample volumes and digit multipliers .....	20
Interferences .....	21
Use CDTA to remove metal interferences .....	22
Replacement items .....	23
Optional items .....	23
<b>Iron</b> .....	25
Test preparation .....	25
Test procedure—Iron (0–0.2 mg/L Fe) .....	25
Test procedure—Iron (0–2 mg/L Fe) .....	26
Interferences .....	27
Replacement items .....	27
Optional items .....	28

## Table of Contents

---

<b>Nitrite</b> .....	29
Test preparation .....	29
Test procedure—Nitrite (0–80 mg/L NO <sub>2</sub> <sup>-</sup> ).....	29
Test procedure—Nitrite (0–1600 mg/L NO <sub>2</sub> <sup>-</sup> ).....	30
Replacement items .....	31
Optional items .....	31
<b>pH</b> .....	32
Test preparation .....	32
Test procedure—pH (5.6–8.4 pH units).....	32
Test procedure—pH (7.4–9.6 pH units).....	33
Replacement items .....	33
Optional items .....	33
<b>Phosphate</b> .....	35
Test preparation .....	35
Filtration procedure for turbid samples.....	35
Test procedure—Orthophosphate high range (0–40 mg/L PO <sub>4</sub> ).....	36
Digestion procedure for total inorganic phosphate.....	37
Interferences.....	38
Replacement items .....	38
Optional items .....	39
<b>Silica</b> .....	40
Test preparation .....	40
Test procedure—Silica (0–30 mg/L SiO <sub>2</sub> ).....	40
Test procedure—Silica (0–300 mg/L SiO <sub>2</sub> ).....	41
Replacement items .....	42
Optional items .....	43
<b>Sulfite</b> .....	44
Test preparation .....	44
Test procedure—Sulfite (mg/L SO <sub>3</sub> <sup>2-</sup> ).....	44
Sample volumes and digit multipliers .....	45
Interferences.....	45
Replacement items .....	46
Optional items .....	46
<b>Total dissolved solids (TDS)</b> .....	47
Optional items .....	47

## General information

In no event will the manufacturer be liable for direct, indirect, special, incidental or consequential damages resulting from any defect or omission in this manual. The manufacturer reserves the right to make changes in this manual and the products it describes at any time, without notice or obligation. Revised editions are found on the manufacturer's website.

## Safety information

### NOTICE

The manufacturer is not responsible for any damages due to misapplication or misuse of this product including, without limitation, direct, incidental and consequential damages, and disclaims such damages to the full extent permitted under applicable law. The user is solely responsible to identify critical application risks and install appropriate mechanisms to protect processes during a possible equipment malfunction.

Please read this entire manual before unpacking, setting up or operating this equipment. Pay attention to all danger and caution statements. Failure to do so could result in serious injury to the operator or damage to the equipment.

Make sure that the protection provided by this equipment is not impaired. Do not use or install this equipment in any manner other than that specified in this manual.

## Use of hazard information

### ▲ DANGER

Indicates a potentially or imminently hazardous situation which, if not avoided, will result in death or serious injury.

### ▲ WARNING

Indicates a potentially or imminently hazardous situation which, if not avoided, could result in death or serious injury.

### ▲ CAUTION

Indicates a potentially hazardous situation that may result in minor or moderate injury.

### NOTICE

Indicates a situation which, if not avoided, may cause damage to the instrument. Information that requires special emphasis.

## Product overview

The professional boiler and cooling water test kit includes the necessary items to measure important parameters in boiler and cooling water. Refer to [Table 1](#).

Some measurement methods use reagents and color discs to make a visual determination of the parameter concentration. Refer to [Figure 1](#). Other measurement methods use reagents and titration procedures to measure the parameter concentration.

Use the Digital Titrator for the titration procedures. Refer to the supplied documentation for the correct operation of the Digital Titrator. The Digital Titrator documentation also has more accuracy check procedures and descriptions of the chemical reactions.

**Table 1 Test kit parameters**

Parameter	Range	Method
Alkalinity	0–4000 mg/L CaCO <sub>3</sub>	Titration
Chloride	0–8000 mg/L Cl <sup>-</sup>	Titration
Chlorine, total	0–3.4 mg/L Cl <sub>2</sub>	Color disc
Hardness, total	0–4000 mg/L CaCO <sub>3</sub>	Titration

**Table 1 Test kit parameters (continued)**

Parameter	Range	Method
Iron	0–0.2, 0–2.0 mg/L Fe	Color disc
Nitrite	0–1600 mg/L NO <sub>2</sub>	Color disc
pH	5.6–8.4, 7.4–9.6 pH units	Color disc
Phosphate	0–40 mg/L PO <sub>4</sub>	Color disc
Silica	0–30, 0–300 mg/L SiO <sub>2</sub>	Color disc
Sulfite	0–800 mg/L SO <sub>3</sub>	Titration
Total dissolved solids (TDS)	0–1999 ppm TDS	Pocket Pro™ TDS <sub>LR</sub> Tester

**Figure 1 Color comparator box**

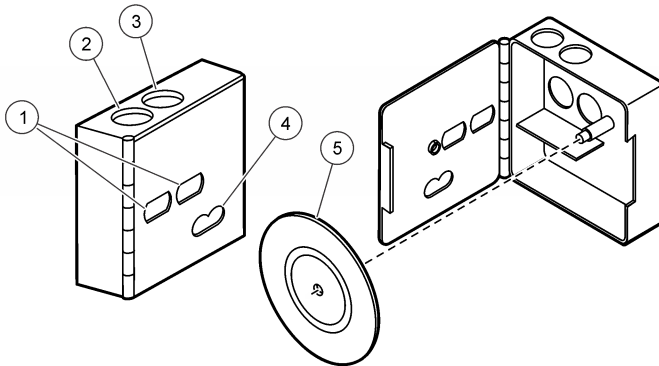

1 Windows for color matching	4 Scale window
2 Left opening for viewing tube	5 Color disc
3 Right opening for viewing tube	

## Product components

Make sure that all components have been received. Refer to the list that follows. If any items are missing or damaged, contact the manufacturer or a sales representative immediately.

- Bottle, mixing (4x)
- Carrying case
- Clamp, test tube
- Clippers
- Color comparator box
- Color discs (8x)
- Color viewing tubes, glass (2x)
- Delivery tubes for Digital Titrator
- Digital Titrator
- Droppers (3x)
- Filter paper, 2–3  $\mu\text{m}$ , 12.5 cm
- Flask, Erlenmeyer, 50 mL
- Flask, Erlenmeyer, 125 mL
- Funnel, plastic
- Graduated cylinder, 10 mL
- Graduated cylinder, 100 mL
- Long-path viewing adaptor
- Pocket Pro Low Range TDS Tester
- Stoppers for color viewing tubes (4x)
- Stove with cover and Heatabs
- Acid Reagent Powder Pillows
- Bromcresol Green-Methyl Red Powder Pillows
- Bromthymol Blue Indicator Solution
- Citric Acid Reagent Powder Pillows
- Diphenylcarbazone Reagent Powder Pillows
- Dissolved Oxygen 3 Powder Pillows (4x)
- DPD Total Chlorine Reagent Powder Pillows
- EDTA Digital Titrator Cartridge, 0.0800 M
- EDTA Digital Titrator Cartridge, 0.800 M
- Filtration aid solution
- Hardness 1 Buffer Solution
- Iodate-Iodide Digital Titrator Cartridge, 0.3998 N
- ManVer 2 Hardness Indicator Powder Pillows
- Mercuric Nitrate Digital Titrator Cartridge, 0.2256 N
- Mercuric Nitrate Digital Titrator Cartridge, 2.256 N
- Molybdate Reagent Powder Pillows
- NitriVer 2 Nitrite Reagent Powder Pillows
- Phenolphthalein Indicator Powder Pillows
- PhosVer 3 Reagent Powder Pillows
- Silica 3 Reagent Powder Pillows
- Sodium Hydroxide Standard Solution, 5.0 N
- Starch Indicator Solution
- Sulfuric Acid Digital Titrator Cartridge, 0.1600 N
- Sulfuric Acid Digital Titrator Cartridge, 1.600 N
- Sulfuric Acid Standard Solution, 5.25 N
- Thymol Blue Indicator Solution
- TPTZ Iron Reagent Powder Pillows

# Alkalinity

## Test preparation

### ▲ CAUTION

Review the Safety Data Sheets (MSDS/SDS) for the chemicals that are used. Use the recommended personal protective equipment.

- Discard or clean the delivery tube immediately after use so the titrant does not dry and clog the tube. To clean, use a syringe or wash bottle to push water, then air through the tube.
- Keep the cap on the titration cartridge when not in use.
- Rinse the graduated cylinder and flask with deionized water after the test. Rinse the graduated cylinder with sample before the test.
- Alkalinity is the capacity of water to neutralize acids. Carbonates, bicarbonates and hydroxides are the primary sources of alkalinity in water. A high total alkalinity value makes water more resistant to pH changes. In a boiler system, alkalinity is controlled to prevent corrosion from low pH and also to prevent scaling from calcium precipitates.
- Alkalinity procedures use two endpoints. The first endpoint, phenolphthalein (pH 8.3), measures the total hydroxide and one half of the carbonate ions in the sample. The second endpoint, total, measures all carbonate, bicarbonate and hydroxide ions. The pH of the second endpoint can be different for different alkalinity levels and sample compositions. Refer to [Alkalinity pH endpoints](#) on page 8.
- To help see the correct endpoint color, mix one pH Buffer Powder Pillow of the applicable endpoint pH in 50 mL of deionized water, then add one Bromcresol Green-Methyl Red Powder Pillow. Compare the color of the buffer indicator solution to the sample during the titration. If an endpoint pH of 3.7 is used, use a Bromphenol Blue Powder Pillow and titrate to a green endpoint.
- As an alternative to the Phenolphthalein Indicator Powder Pillow, use 4 drops of Phenolphthalein Indicator Solution.
- As an alternative to the Bromcresol Green-Methyl Red Indicator Powder Pillow, use 4 drops of Bromcresol Green-Methyl Red Indicator Solution or 4 drops of Methyl Purple Indicator Solution.
- Color or turbidity in the sample can make it difficult to see the color change at the endpoint. If the sample contains color or turbidity, use a pH meter to determine the titration endpoint.
- To verify the test accuracy, use a standard solution as the sample.

## Sample collection

- Collect samples in clean glass or plastic bottles with tight-fitting caps. Completely fill the bottle and immediately tighten the cap.
- Prevent agitation of the sample and exposure to air.
- Analyze the samples as soon as possible for best results.
- If immediate analysis is not possible, keep the samples at or below 6 °C (43 °F) for a maximum of 24 hours.
- Let the sample temperature increase to room temperature before analysis.



## Test procedure—Alkalinity (mg/L as CaCO<sub>3</sub>)

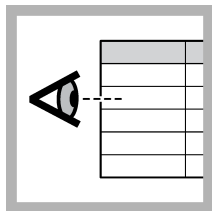

1. Select a sample volume and titration cartridge from [Table 2](#) on page 8.

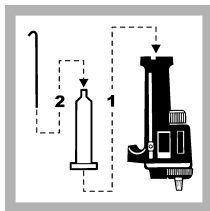

2. Attach the titration cartridge to the Digital Titrator. Insert a clean delivery tube into the cartridge.



3. Hold the Digital Titrator with the cartridge tip up. Turn the delivery knob to eject air and a few drops of titrant. Reset the counter to zero and wipe the tip.

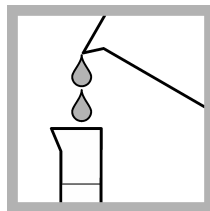

4. Use a graduated cylinder to measure the sample volume from [Table 2](#) on page 8.



5. Pour the sample into a clean, 125-mL Erlenmeyer flask.

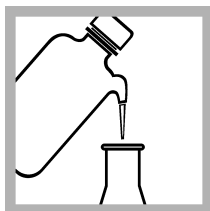

6. If the sample volume is less than 100 mL, dilute to approximately 100 mL with deionized water.

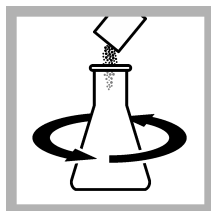

7. Add one Phenolphthalein Powder Pillow. Swirl to mix. A pink color develops. If a pink color does not develop, the phenolphthalein alkalinity is zero. Go to step 11.

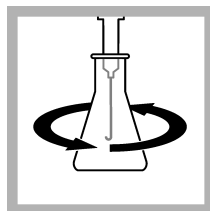

8. Put the end of the delivery tube fully into the solution. Swirl the flask.

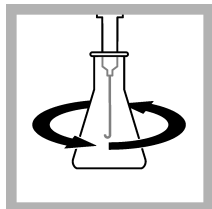

9. Turn the knob on the Digital Titrator to add titrant to the solution. Continue to swirl the flask. Add titrant until the color changes from pink to colorless.

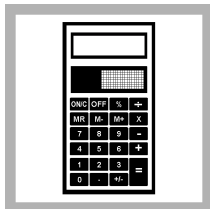

10. Record the number of digits on the counter. Use the digit multiplier in [Table 2](#) on page 8 to calculate the concentration. Digits used x digit multiplier = mg/L as CaCO<sub>3</sub> Phenolphthalein alkalinity.

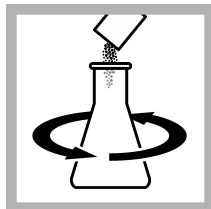

11. Add one Bromcresol Green-Methyl Red Powder Pillow. Swirl to mix.

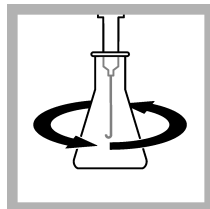

12. Put the end of the delivery tube fully into the solution. Swirl the flask.

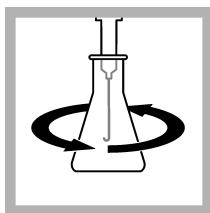

13. Turn the knob on the Digital Titrator to add titrant to the solution. Continue to swirl the flask. Add titrant until the color changes light greenish blue-gray (pH 5.1), a light violet-gray (pH 4.8) or a light pink (pH 4.5).

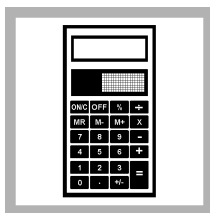

14. Record the number of digits on the counter. Use the digit multiplier in Table 2 on page 8 to calculate the concentration. Total digits used x digit multiplier = mg/L as CaCO<sub>3</sub> Total alkalinity.

## Sample volumes and digit multipliers

Use an approximate alkalinity concentration (as mg/L CaCO<sub>3</sub>) to find the sample volume, titration cartridge and digit multiplier from Table 2. Use the digit multiplier to calculate the concentration at the end of the test procedure.

Table 2 Sample volumes and digit multipliers

Range (mg/L as CaCO <sub>3</sub> )	Sample volume (mL)	Titration cartridge	Digit multiplier
10–40	100	0.1600 N H <sub>2</sub> SO <sub>4</sub>	0.1
40–160	25	0.1600 N H <sub>2</sub> SO <sub>4</sub>	0.4
100–400	100	1.600 N H <sub>2</sub> SO <sub>4</sub>	1
200–800	50	1.600 N H <sub>2</sub> SO <sub>4</sub>	2
500–2000	20	1.600 N H <sub>2</sub> SO <sub>4</sub>	5
1000–4000	10	1.600 N H <sub>2</sub> SO <sub>4</sub>	10

## Alkalinity pH endpoints

The titration pH endpoints in Table 3 are recommended for alkalinity determinations in water samples of various compositions and alkalinity concentrations.

Table 3 Alkalinity pH endpoints

Sample composition	Phenolphthalein alkalinity	Total alkalinity
Alkalinity approximately 30 mg/L	pH 8.3	pH 4.9
Alkalinity approximately 150 mg/L	pH 8.3	pH 4.6
Alkalinity approximately 500 mg/L	pH 8.3	pH 4.3
Contains silicates or phosphates	pH 8.3	pH 4.5
Industrial wastes or complex system	pH 8.3	pH 4.5
Routine or automated analyses	pH 8.3	pH 4.5

## Determine the alkalinity relationships

The primary forms of alkalinity in water are hydroxide, carbonate and bicarbonate ions. The concentration of these ions in a sample can be determined from the phenolphthalein alkalinity and total alkalinity values. Refer to [Table 4](#) and the steps that follow to determine the hydroxide, carbonate and bicarbonate alkalinities.

- If the phenolphthalein (P) alkalinity is 0 mg/L, use Row 1.
- If the phenolphthalein (P) alkalinity is equal to the total alkalinity, use Row 2.
- Divide the total alkalinity by 2 to calculate one-half of the total alkalinity.
  - Compare the phenolphthalein (P) alkalinity to one-half of the total alkalinity. Then, use Row 3, 4 or 5.
  - Do the calculations in the row (if applicable).
- Make sure that the sum of the three alkalinity types is equal to the total alkalinity.

### Example:

A sample has 170 mg/L as CaCO<sub>3</sub> phenolphthalein alkalinity and 250 mg/L as CaCO<sub>3</sub> total alkalinity.

The phenolphthalein alkalinity of 170 mg/L is more than one-half of the total alkalinity, so use Row 5.

- Hydroxide alkalinity:  $2 \times 170 = 340$ ;  $340 - 250 = 90$  mg/L hydroxide alkalinity
- Carbonate alkalinity:  $250 - 170 = 80$ ;  $80 \times 2 = 160$  mg/L carbonate alkalinity
- Bicarbonate alkalinity: 0 mg/L

Sum of the alkalinity types: 90 mg/L hydroxide alkalinity + 160 mg/L carbonate alkalinity + 0 mg/L bicarbonate alkalinity = 250 mg/L total alkalinity.

**Table 4 Alkalinity relationships**

Row	Titration result	Hydroxide alkalinity	Carbonate alkalinity	Bicarbonate alkalinity
1	P alkalinity = 0	0	0	= Total alkalinity
2	P alkalinity = Total alkalinity	= Total alkalinity	0	0
3	P alkalinity is less than ½ of Total alkalinity	0	= P alkalinity × 2	= Total alkalinity – (P alkalinity × 2)
4	P alkalinity = ½ Total alkalinity	0	= Total alkalinity	0
5	P alkalinity is more than ½ Total alkalinity	= (P alkalinity × 2) – Total alkalinity	= (Total alkalinity – P alkalinity) × 2	0

## Interferences

Interfering substance	Interference level
Chlorine	Chlorine at levels more than 3.5 mg/L can cause a yellow-brown color when the Bromocresol Green-Methyl Red Powder Pillow is added. Add 1 drop of 0.1 N Sodium Thiosulfate to the sample to remove chlorine before the test is started.
Color or turbidity	Color or turbidity can make it difficult to see the color change at the endpoint. Do not filter or dilute samples with color or turbidity. Use a pH meter and titrate the samples to a pH of 8.3 for phenolphthalein alkalinity. For total alkalinity, refer to <a href="#">Table 3</a> on page 8 for the correct endpoint pH.
Soaps, oily matter, suspended solids and precipitates	Oils or solids can collect on the pH probe and cause a slow response. Clean the probe immediately after use (refer to <a href="#">Clean the pH probes</a> on page 10).

## Clean the pH probes

Make sure to clean the pH probes regularly when a pH meter is used to determine the endpoint. Refer to the probe documentation for maintenance instructions. Use the cleaning solution that is specified for the type of contamination that is in the sample. Clean the probe when one or more of the conditions that follow occur:

- Drifting/inaccurate readings
- Slow stabilization times
- Calibration errors

## Replacement items

**Note:** Product and Article numbers may vary for some selling regions. Contact the appropriate distributor or refer to the company website for contact information.

Description	Unit	Item no.
Alkalinity Reagent Set (~100 tests), includes 1 each of 94299, 94399, 1438801, 1438901	each	2271900
Bromcresol Green-Methyl Red Indicator Powder Pillows	100/pkg	94399
Cylinder, graduated, polypropylene, 10 mL	each	108138
Cylinder, graduated, polypropylene, 100 mL	each	108142
Delivery tube for Digital Titrator	5/pkg	1720500
Flask, Erlenmeyer, 125 mL	each	50543
Phenolphthalein Indicator Powder Pillows	100/pkg	94299
Sulfuric Acid Digital Titrator Cartridge, 0.1600 N	each	1438801
Sulfuric Acid Digital Titrator Cartridge, 1.600 N	each	1438901

## Optional items

Description	Unit	Item no.
Alkalinity standard solution, 500 mg/L as CaCO <sub>3</sub>	1 L	2826253
Bottle, wash, polyethylene, 500 mL	each	62011
Bromcresol Green-Methyl Red Indicator Solution	100 mL MDB	2329232
Bromphenol Blue Indicator Powder Pillows	100/pkg	1455099
Bromphenol Blue Indicator Solution	100 mL MDB	1455232
Buffer Powder Pillows, pH 4.50, 50 mL	25/pkg	89568
Buffer Powder Pillows, pH 8.30, 50 mL	25/pkg	89868
Cylinder, graduated, polypropylene, 25 mL	each	108140
Cylinder, graduated, polypropylene, 50 mL	each	108141
Demineralizer bottle, 473-mL capacity	each	2184600
Flask, Erlenmeyer, 250 mL	each	50546
Methyl Purple Indicator Solution	100 mL MDB	2193432
Phenolphthalein Indicator Solution, 5 g/L	100 mL MDB	16232
Sodium thiosulfate standard solution, 0.1 N	100 mL MDB	32332

## Optional items (continued)

Description	Unit	Item no.
TitraStir® Titration Stand, 115 VAC	each	1940000
TitraStir® Titration Stand, 230 VAC	each	1940010
Delivery tube for Digital Titrator, 90-degree bend for use with TitraStir Titration Stand	5/pkg	4157800
Water, deionized	500 mL	27249

# Chloride

## Test preparation

### ⚠ CAUTION

Review the Safety Data Sheets (MSDS/SDS) for the chemicals that are used. Use the recommended personal protective equipment.

- Collect samples in clean glass or plastic bottles. If prompt analysis is not possible, keep the sample for a maximum of 28 days.
- If the sample is strongly alkaline or acidic, add 5.25 N sulfuric acid or 5.0 N sodium hydroxide until the pH is between 2 and 7. If a pH meter is used, use a separate sample to find the correct amount of acid or base to use. Then add the same amount of acid or base to the sample. pH electrodes will contaminate the sample. Correct the test result for the dilution caused by the volume additions.
- Discard or clean the delivery tube immediately after use so the titrant does not dry and clog the tube. To clean, use a syringe or wash bottle to push water, then air through the tube.
- Keep the cap on the titration cartridge when not in use.
- Rinse the graduated cylinder and flask with deionized water after the test. Rinse the graduated cylinder with sample before the test.
- Undissolved reagent does not have an effect on test accuracy.
- To verify the test accuracy, use a standard solution as the sample.
- To record the test result as mg/L sodium chloride (NaCl), multiply the chloride result by 1.65.
- In boiler water, the chloride concentration is used to determine when the dissolved solids have increased to a level that requires removal by blowdown.

## Test procedure—Chloride (mg/L Cl<sup>-</sup>)

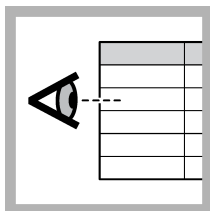

1. Select a sample volume and titration cartridge from [Table 5](#) on page 13.

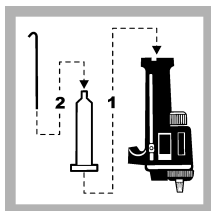

2. Attach the titration cartridge to the Digital Titrator. Insert a clean delivery tube into the cartridge.



3. Hold the Digital Titrator with the cartridge tip up. Turn the delivery knob to eject air and a few drops of titrant. Reset the counter to zero and wipe the tip.

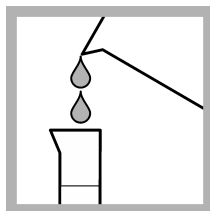

4. Use a graduated cylinder to measure the sample volume from [Table 5](#) on page 13.



5. Pour the sample into a clean, 125-mL Erlenmeyer flask.

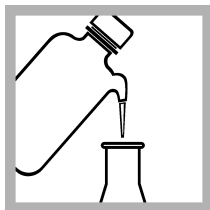

6. If the sample volume is less than 100 mL, dilute to approximately 100 mL with deionized water.

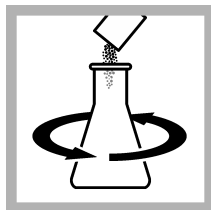

7. Add one Diphenylcarbazone Reagent Powder Pillow. Swirl to mix.

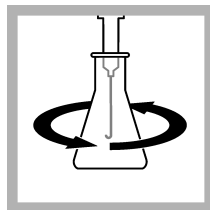

8. Put the end of the delivery tube fully into the solution. Swirl the flask.

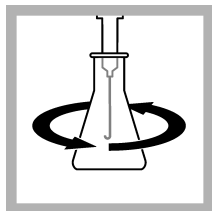

9. Turn the knob on the Digital Titrator to add titrant to the solution. Continue to swirl the flask. Add titrant until the color changes to blue.

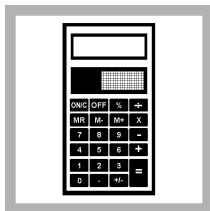

10. Record the number of digits on the counter. Use the digit multiplier in [Table 5](#) on page 13 to calculate the concentration.  
 Digits used x digit multiplier = mg/L chloride.

## Sample volumes and digit multipliers

Use an approximate chloride concentration (as mg/L  $\text{Cl}^-$ ) to find the sample volume from [Table 5](#). Use the digit multiplier to calculate the concentration at the end of the test procedure.

**Table 5 Sample volumes and digit multipliers**

Range (mg/L as $\text{Cl}^-$ )	Sample volume (mL)	Titration cartridge	Digit multiplier
10–40	100	0.2256 N $\text{Hg}(\text{NO}_3)_2$	0.1
40–160	25	0.2256 N $\text{Hg}(\text{NO}_3)_2$	0.4
100–400	100	2.256 N $\text{Hg}(\text{NO}_3)_2$	1.0
200–800	50	2.256 N $\text{Hg}(\text{NO}_3)_2$	2.0
500–2000	20	2.256 N $\text{Hg}(\text{NO}_3)_2$	5.0
1000–4000	10	2.256 N $\text{Hg}(\text{NO}_3)_2$	10.0
2000–8000	5	2.256 N $\text{Hg}(\text{NO}_3)_2$	20.0

## Interferences

Interfering substance	Interference level
Bromide	Interferes directly and is included in the test result.
Chromate	Concentrations that are more than 10 mg/L interfere with this method.
Iodide	Interferes directly and is included in the test result.
Iron, ferric	Concentrations that are more than 10 mg/L interfere with this method.
Highly buffered samples or extreme sample pH	Can prevent the correct pH adjustment (of the sample) by the reagents. Sample pretreatment may be necessary.
Sulfide	Remove sulfide interference as follows: <ol style="list-style-type: none"> <li>1. Add the contents of one Sulfide Inhibitor Reagent Powder Pillow to approximately 125 mL of sample.</li> <li>2. Mix for 1 minute.</li> <li>3. Pour the solution through folded filter paper in a funnel.</li> <li>4. Use the filtered sample in the chloride test procedure.</li> </ol>
Sulfite	Concentrations that are more than 10 mg/L interfere with this method. To remove sulfite interference, add 3 drops of 30% Hydrogen Peroxide to the sample, then start the test.

## Replacement items

**Note:** Product and Article numbers may vary for some selling regions. Contact the appropriate distributor or refer to the company website for contact information.

Description	Unit	Item no.
Chloride Reagent Set (~100 tests), mercuric nitrate, includes 83699, 1439301, 92101	each	2272000
Cylinder, graduated, polypropylene, 10 mL	each	108138
Cylinder, graduated, polypropylene, 100 mL	each	108142
Delivery tube for Digital Titrator	5/pkg	1720500
Diphenylcarbazone Reagent Powder Pillows	100/pkg	83699
Flask, Erlenmeyer, 125 mL	each	50543
Mercuric Nitrate Digital Titrator Cartridge, 0.2256 N	each	1439301
Mercuric Nitrate Digital Titrator Cartridge, 2.256 N	each	92101

## Optional items

Description	Unit	Item no.
Bottle, wash, polyethylene, 500 mL	each	62011
Cylinder, graduated, polypropylene, 5 mL	each	50837
Cylinder, graduated, polypropylene, 25 mL	each	108140
Cylinder, graduated, polypropylene, 50 mL	each	108141
Demineralizer bottle, 473-mL capacity	each	2184600
Chloride standard solution, 1000 mg/L Cl <sup>-</sup>	500 mL	18349



## Optional items (continued)

Description	Unit	Item no.
Filter paper, 2–3 micron, pleated, 12.5 cm	100/pkg	189457
Flask, Erlenmeyer, 250 mL	each	50546
Funnel, poly, 65 mm	each	108367
Hydrogen Peroxide Solution, 30%	473 mL	14411
Sodium hydroxide standard solution, 5.0 N	100 mL MDB	245032
Sulfide Inhibitor Reagent Powder Pillows	100/pkg	241899
Sulfuric acid standard solution, 5.25 N	100 mL MDB	244932
TitraStir <sup>®</sup> Titration Stand, 115 VAC	each	1940000
TitraStir <sup>®</sup> Titration Stand, 230 VAC	each	1940010
Delivery tube for Digital Titrator, 90-degree bend for use with TitraStir Titration Stand	5/pkg	4157800
Water, deionized	500 mL	27249

# Total Chlorine

## Test preparation

### ⚠ CAUTION

Review the Safety Data Sheets (MSDS/SDS) for the chemicals that are used. Use the recommended personal protective equipment.

### NOTICE

This product has not been evaluated to test for chlorine and chloramines in medical applications in the United States.

- Analyze samples immediately after collection.
- Put the color disc on the center pin in the color comparator box (numbers to the front).
- Use sunlight or a lamp as a light source to find the color match with the color comparator box.
- Rinse the tubes with sample before the test. Rinse the tubes with deionized water after the test.
- If the color match is between two segments, use the value that is in the middle of the two segments.
- If the color disc becomes wet internally, pull apart the flat plastic sides to open the color disc. Remove the thin inner disc. Dry all parts with a soft cloth. Assemble when fully dry.
- Undissolved reagent does not have an effect on test accuracy.
- If the test result is more than the limit of the test, or if the sample temporarily becomes yellow after the reagent addition, dilute the sample with a known volume of high quality, chlorine demand-free water and do the test again. Some loss of chlorine may occur due to the dilution. Multiply the result by the dilution factor.
- Chlorine is added to cooling water to control biological growth. Monitor the chlorine content to control the growth of slime but at the same time not cause corrosion of pipes and fittings.

## Test procedure—Total chlorine (0–3.4 mg/L Cl<sub>2</sub>)

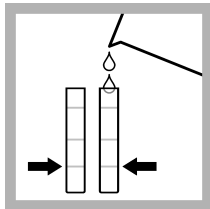

1. Fill two tubes to the first line (5 mL) with sample.

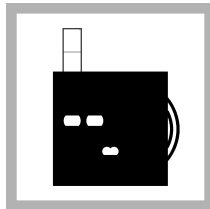

2. Put one tube into the left opening of the color comparator box.

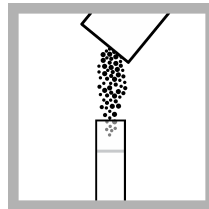

3. Add one DPD Total Chlorine Powder Pillow to the second tube.



4. Wait 3 minutes. Read the result within 6 minutes.

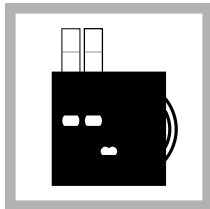

5. Put the second tube into the color comparator box.

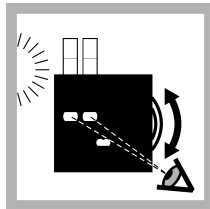

6. Hold the color comparator box in front of a light source. Turn the color disc to find the color match.

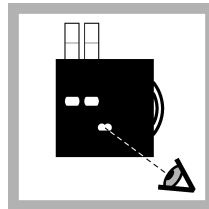

7. Read the result in mg/L in the scale window.

## Interferences

Interfering substance	Interference level
Acidity	More than 150 mg/L CaCO <sub>3</sub> . The full color may not develop or the color may fade instantly. Adjust to pH 6–7 with 1 N Sodium Hydroxide. Measure the amount to be added on a separate sample aliquot, then add the same amount to the sample that is tested. Correct the test result for the dilution from the volume addition.
Alkalinity	More than 250 mg/L CaCO <sub>3</sub> . The full color may not develop or the color may fade instantly. Adjust to pH 6–7 with 1 N Sulfuric Acid. Measure the amount to add on a separate sample aliquot, then add the same amount to the sample that is tested. Correct the test result for the dilution from the volume addition.
Bromine, Br <sub>2</sub>	Interferes at all levels
Chlorine Dioxide, ClO <sub>2</sub>	Interferes at all levels
Chloramines, organic	May interfere
Hardness	No effect at less than 1000 mg/L as CaCO <sub>3</sub>
Iodine, I <sub>2</sub>	Interferes at all levels
Manganese, Oxidized (Mn <sup>4+</sup> , Mn <sup>7+</sup> ) or Chromium, Oxidized (Cr <sup>6+</sup> )	Pre-treat the sample as follows: <ol style="list-style-type: none"> <li>1. Adjust the sample pH to 6–7.</li> <li>2. Add 3 drops of Potassium Iodide (30-g/L) to 10 mL of sample.</li> <li>3. Mix and wait 1 minute.</li> <li>4. Add 3 drops of Sodium Arsenite (5-g/L) and mix.</li> <li>5. Use the test procedure to measure the concentration of the treated sample.</li> <li>6. Subtract this result from the result without the treatment to obtain the correct chlorine concentration.</li> </ol>
Ozone	Interferes at all levels
Peroxides	May interfere
Highly buffered samples or extreme sample pH	Can prevent the correct pH adjustment (of the sample) by the reagents. Sample pretreatment may be necessary.

## Replacement items

**Note:** Product and Article numbers may vary for some selling regions. Contact the appropriate distributor or refer to the company website for contact information.

Description	Unit	Item no.
DPD Total Chlorine Reagent Powder Pillows, 5 mL	100/pkg	1407699
Color disc, DPD chlorine, 0–3.4 mg/L	each	990200
Color comparator box	each	173200
Glass viewing tubes, 18 mm	6/pkg	173006
Stoppers for 18-mm glass tubes and AccuVac Ampuls	6/pkg	173106

## Optional items

Description	Unit	Item no.
Potassium iodide solution, 30 g/L	100 mL MDB	34332
Sodium arsenite solution, 5 g/L	100 mL	104732

## Optional items (continued)

Description	Unit	Item no.
Sodium hydroxide standard solution, 1.0 N	100 mL MDB	104532
Sulfuric acid standard solution, 1.0 N	100 mL MDB	127032
Water, deionized	500 mL	27249

# Hardness, Total

## Test preparation

### ▲ CAUTION

Review the Safety Data Sheets (MSDS/SDS) for the chemicals that are used. Use the recommended personal protective equipment.

- If prompt analysis is not possible, preserve the sample for later analysis. Refer to [Sample collection and storage](#) on page 19.
- If the sample volume is 100 mL and the sample contains more than 400 mg/L acidity as  $\text{CaCO}_3$ , use 2 mL of the Hardness 1 Buffer Solution.
- Discard or clean the delivery tube immediately after use so the titrant does not dry and clog the tube. To clean, use a syringe or wash bottle to push water, then air through the tube.
- Keep the cap on the titration cartridge when not in use.
- Rinse the graduated cylinder and flask with deionized water after the test. Rinse the graduated cylinder with sample before the test.
- To verify the test accuracy, use a standard solution as the sample.
- Titrate slowly near the endpoint because the reaction is slow, especially in cold samples.
- To determine the concentration of calcium and magnesium independently, refer to the sequential hardness procedure in the Digital Titrator User Manual.
- As an alternative to the ManVer 2 Hardness Indicator Powder Pillow, use 4 drops of Hardness 2 Indicator Solution or a 0.1 g scoop of bulk ManVer 2 Hardness Indicator Powder.
- Use the optional 0.1428 M or 0.714 M EDTA Digital Titrator Cartridge for results as Gdh (German degrees of hardness), or multiply the result as  $\text{CaCO}_3$  by 0.056 to get the result as Gdh.
- Hardness in boiler or cooling water can cause scale in the system and decrease the efficiency of the boiler or cooling tower.

## Sample collection and storage

- Collect samples in clean glass or plastic bottles that have been cleaned with a detergent and rinsed with 1:1 nitric acid and deionized water.
- To preserve samples for later analysis, adjust the sample pH to 2 or less with concentrated nitric acid (about 2 mL per liter). No acid addition is necessary if the sample is tested immediately.
- Keep the preserved samples at or below 6 °C (43 °F) for a maximum of 6 months.
- Before analysis, adjust the pH to ~7 with 5 N sodium hydroxide solution.
- Correct the test result for the dilution caused by the volume additions.

## Test procedure—Hardness (mg/L CaCO<sub>3</sub>)

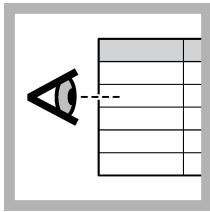

1. Select a sample volume and titration cartridge from [Table 6](#) on page 21.

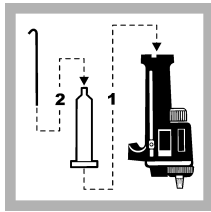

2. Attach the titration cartridge to the Digital Titrator. Insert a clean delivery tube into the cartridge.



3. Hold the Digital Titrator with the cartridge tip up. Turn the delivery knob to eject air and a few drops of titrant. Reset the counter to zero and wipe the tip.

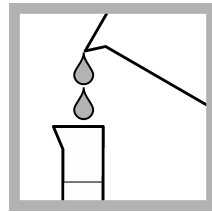

4. Use a graduated cylinder to measure the sample volume from [Table 6](#) on page 21.

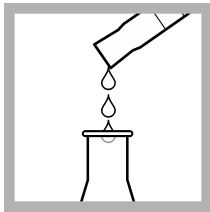

5. Pour the sample into a clean, 125-mL Erlenmeyer flask.

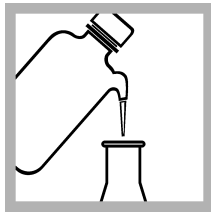

6. If the sample volume is less than 100 mL, dilute to approximately 100 mL with deionized water.

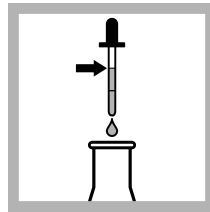

7. Use the 1-mL dropper to add 1 mL of the Hardness 1 Buffer Solution. Swirl to mix.

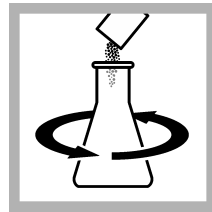

8. Add one ManVer 2 Reagent Powder Pillow. Swirl to mix.

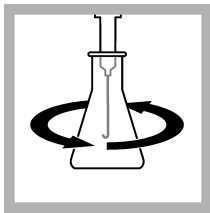

9. Put the end of the delivery tube fully into the solution. Swirl the flask.

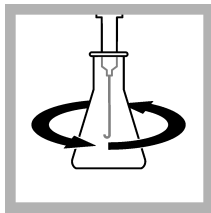

10. Turn the knob on the Digital Titrator to add titrant to the solution. Continue to swirl the flask. Add titrant until the color changes from pink to pure blue.

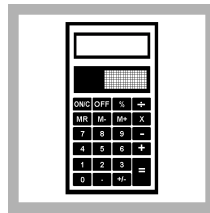

11. Record the number of digits on the counter. Use the digit multiplier in [Table 6](#) on page 21 to calculate the concentration. Digits used x digit multiplier = mg/L hardness.

## Sample volumes and digit multipliers

Select a range in [Table 6](#) or [Table 7](#) as applicable, then read across the table row to find the applicable information for this test. Use the digit multiplier to calculate the concentration in the test procedure.

**Example:** A 50-mL sample was titrated with 0.800 M EDTA titration cartridge and the counter showed 250 digits at the endpoint. The concentration is  $250 \text{ digits} \times 2.0 = 500 \text{ mg/L}$  as  $\text{CaCO}_3$  (or with the 0.714 M EDTA titration cartridge,  $250 \times 0.1 = 25 \text{ mg/L Gdh}$ ).

**Table 6 Sample volumes and digit multipliers—mg/L**

Range (mg/L as $\text{CaCO}_3$ )	Sample volume (mL)	Titration cartridge	Digit multiplier
10–40	100	0.0800 M EDTA	0.1
40–160	25	0.0800 M EDTA	0.4
100–400	100	0.800 M EDTA	1.0
200–800	50	0.800 M EDTA	2.0
500–2000	20	0.800 M EDTA	5.0
1000–4000	10	0.800 M EDTA	10.0

**Table 7 Sample volumes and digit multipliers—Gdh**

Range (Gdh as $\text{CaCO}_3$ )	Sample volume (mL)	Titration cartridge	Digit multiplier
1–4	100	0.1428 M EDTA	0.01
4–16	25	0.1428 M EDTA	0.04
10–40	50	0.714 M EDTA	0.1
25–100	20	0.714 M EDTA	0.25
> 100	10	0.714 M EDTA	0.5

## Interferences

<b>⚠ WARNING</b>	
	Chemical hazard. Potassium cyanide is toxic. Make sure to add potassium cyanide to the sample after the Hardness 1 Buffer Solution has been added. Keep cyanide solutions at more than pH 11 to prevent exposure to hydrogen cyanide gas. Dispose of reacted solutions according to local, state and federal regulations.

An interfering substance can prevent the color change at the titration endpoint. A smaller sample volume can often dilute the interfering substance to a level at which the substance does not interfere. [Table 8](#) shows the substances that can interfere with this test.

**Table 8 Interferences**

Interfering substance	Interference level
Acidity	10,000 mg/L acidity as $\text{CaCO}_3$ does not interfere.
Alkalinity	10,000 mg/L alkalinity as $\text{CaCO}_3$ does not interfere.
Aluminum	Interferes when the sample contains more than 0.20 mg/L aluminum. Add 1.0 gram of potassium cyanide after the Hardness 1 Buffer Solution during the test procedure to remove the interference from a maximum of 1 mg/L aluminum. As an alternative, add a CDTA Powder Pillow to remove the interference.
Barium	Barium is titrated at the same time with calcium and interferes with this test, but it is unusual to find high levels of Barium in natural waters.
Chloride	The chloride level in seawater does not interfere. Solutions that are saturated with chloride do not show a sharp endpoint.
Cobalt	Interferes directly and is included in the test result. Add 0.5 grams of potassium cyanide after the Hardness 1 Buffer Solution during the test procedure to remove the interference from a maximum of 100 mg/L cobalt. As an alternative, add a CDTA Powder Pillow to remove the interference.

**Table 8 Interferences (continued)**

Interfering substance	Interference level
Copper	Interferes when the sample contains 0.1 mg/L copper. Add 0.5 grams of potassium cyanide after the Hardness 1 Buffer Solution during the test procedure to remove the interference from a maximum of 100 mg/L copper. As an alternative, add a CDTA powder pillow to remove the interference.
Iron	More than 15 mg/L iron causes an orange-red to green endpoint. Results are accurate to 30 mg/L iron with this endpoint. Use a CDTA Digital Titrator Cartridge if an iron interference is probable.
Manganese	Titrate directly, but masks the endpoint above 20 mg/L. Add 0.1 grams of hydroxylamine hydrochloride to increase the level to 200 mg/L manganese.
Nickel	Interferes directly and is included in the test result. Add 0.5 grams of potassium cyanide after the Hardness 1 Buffer Solution during the test procedure to remove the interference from a maximum of 100 mg/L nickel. As an alternative, add a CDTA Powder Pillow to remove the interference.
Orthophosphate	Forms calcium phosphate and causes a slow endpoint. If sufficient time is given to let the calcium phosphate dissolve during the titration, the orthophosphate will not interfere with the test.
Polyphosphates	Interferes at all levels.
Polyvalent metal ions	Although less common than calcium and magnesium, other polyvalent metal ions are titrated with the calcium and magnesium and are included in the results.
Strontium	Strontium is titrated at the same time with calcium and interferes with this test, but it is unusual to find high levels of Strontium in natural waters.
Zinc	Interferes directly and is included in the test result. Add a CDTA Powder Pillow to remove the interference.
Highly buffered samples or extreme sample pH	Can prevent the correct pH adjustment (of the sample) by the reagents. Sample pretreatment may be necessary.

### Use CDTA to remove metal interferences

Add one CDTA Magnesium Salt Powder Pillow to remove the interference from metals at or below the levels shown in [Table 9](#). If more than one metal is in the sample at or more than the concentration in [Table 9](#), add an additional CDTA Magnesium Salt Powder Pillow.

The results given with CDTA Magnesium Salt include the hardness from these metals. If the concentration of each metal is known, a correction can be made to get the hardness from calcium and magnesium only. The hardness value from different metal ions is shown in [Table 10](#).

Metal hardness = (mg/L of metal in the sample) x (hardness equivalence factor)

Calcium and magnesium hardness = (total hardness) – (metal hardness)

**Table 9 Interference level with one CDTA pillow**

Interfering substance	Interference level
Aluminum	50 mg/L
Cobalt	200 mg/L
Copper	100 mg/L
Iron	100 mg/L
Manganese	200 mg/L
Nickel	400 mg/L
Zinc	300 mg/L



**Table 10 Hardness equivalence factors (mg/L as CaCO<sub>3</sub>)**

Interfering substance	Hardness equivalence factor
Aluminum	3.710
Barium	0.729
Cobalt	1.698
Copper	1.575
Iron	1.792
Manganese	1.822
Nickel	1.705
Strontium	1.142
Zinc	1.531

## Replacement items

**Note:** Product and Article numbers may vary for some selling regions. Contact the appropriate distributor or refer to the company website for contact information.

Description	Unit	Item no.
Hardness (Total) Reagent Set (~100 tests), includes 1 each of 42432, 85199, 1436401, 1439901	each	2272000
Cylinder, graduated, polypropylene, 10 mL	each	108138
Cylinder, graduated, polypropylene, 100 mL	each	108142
Delivery tube for Digital Titrator	5/pkg	1720500
EDTA Digital Titrator Cartridge, 0.0800 M	each	1436401
EDTA Digital Titrator Cartridge, 0.800 M	each	1439901
Flask, Erlenmeyer, 125 mL	each	50543
Hardness 1 Buffer Solution	100 mL MDB	42432
ManVer 2 Hardness Indicator Powder Pillows, 50 mL sample	100/pkg	85199

## Optional items

Description	Unit	Item no.
Bottle, wash, polyethylene, 500 mL	each	62011
Calcium standard solution, 1000 mg/L as CaCO <sub>3</sub>	1 L	12153
CDTA Digital Titrator Cartridge, 0.0800 M	each	1440201
CDTA Digital Titrator Cartridge, 0.800 M	each	1440301
CDTA Disodium Magnesium Salt Powder Pillows	100/pkg	1408099
Cylinder, graduated, polypropylene, 25 mL	each	108140
Cylinder, graduated, polypropylene, 50 mL	each	108141
Demineralizer bottle, 473-mL capacity	each	2184600
EDTA Digital Titrator Cartridge, 0.1428 M	each	1496001

## Optional items (continued)

Description	Unit	Item no.
EDTA Digital Titrator Cartridge, 0.714 M	each	1495901
Flask, Erlenmeyer, 250 mL	each	50546
Hardness 2 Indicator Solution	100 mL MDB	42532
Hydroxylamine hydrochloride	113 g	24614
ManVer 2 Hardness Indicator Powder, bulk	113 g	28014
Nitric Acid Solution, 1:1	500 mL	254049
Nitric Acid, ACS	500 mL	15249
pH paper, 1.0 to 11.0 pH range	each	39133
Potassium cyanide	100 g	76714
Sodium hydroxide standard solution, 5.0 N	100 mL MDB	245032
Spoon, measuring, 0.1 g	each	51100
Spoon, measuring, 0.5 g	each	90700
Spoon, measuring, 1.0 g	each	51000
Sulfuric acid standard solution, 5.25 N	100 mL MDB	244932
TitraStir® Titration Stand, 115 VAC	each	1940000
TitraStir® Titration Stand, 230 VAC	each	1940010
Delivery tube for Digital Titrator, 90-degree bend for use with TitraStir Titration Stand	5/pkg	4157800
Water, deionized	500 mL	27249

# Iron

## Test preparation

### ⚠ CAUTION

Review the Safety Data Sheets (MSDS/SDS) for the chemicals that are used. Use the recommended personal protective equipment.

- Put the color disc on the center pin in the color comparator box (numbers to the front).
- Use the color disc that is applicable to the test procedure range.
- Rinse the tubes with sample before the test. Rinse the tubes with deionized water after the test.
- This test is very sensitive to contamination. For best results, clean all glassware with 6.0 N (1:1) hydrochloric acid solution, then rinse fully with deionized water.
- Use a graduated cylinder to add 25 mL of water to the mixing bottle. Write a line on the mixing bottle, then use the line to measure 25 mL of sample in the test procedure.
- If the sample is clear with no color or turbidity, prepare a reagent blank for best results. To prepare a reagent blank, fill the mixing bottle to 25 mL with deionized water. Add one TPTZ Iron Reagent Powder Pillow. Swirl immediately to mix. Pour the solution into a clean viewing tube to the line that is shown in step 2 of the test procedure. Continue the test procedure with step 3.
- If the sample pH is less than 3 or more than 4 after the reagent addition, the color may not fully develop, may fade quickly or turbidity may develop. Adjust the sample pH to 3–8 before the addition of reagent with iron-free acid or base such as 1.0 N Sulfuric Acid Standard Solution or 1.0 N Sodium Hydroxide Standard Solution.
- The long-path adapter for the low range test shows the color in the tubes from top to bottom. Make sure the light source is above the tubes during the color match.
- If the color match is between two segments, use the value that is in the middle of the two segments.
- If the color disc becomes wet internally, pull apart the flat plastic sides to open the color disc. Remove the thin inner disc. Dry all parts with a soft cloth. Assemble when fully dry.
- To verify the test accuracy, use a standard solution as the sample.
- The reagent contains a reducing agent that changes precipitated or suspended iron, such as rust, to ferrous iron ( $\text{Fe}^{2+}$ ). The indicator in the reagent forms a blue color with ferrous iron.
- Copper, cobalt, chromium or mercury in the sample cause an interference that gives high results, but the effect is small.
- The iron concentration can give an indication of the corrosion rate within the system. A regulatory limit may be set on the effluent iron concentration.

## Test procedure—Iron (0–0.2 mg/L Fe)

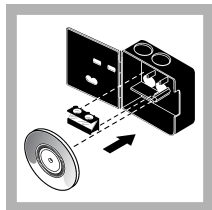

1. Install the long-path adapter in the color comparator box.

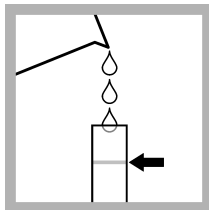

2. Fill a tube to the top line with sample.

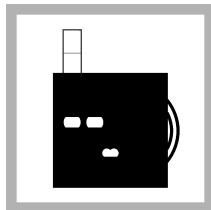

3. Put the tube into the left opening of the color comparator box.

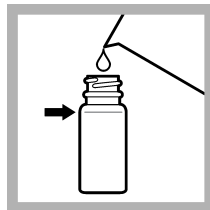

4. Fill a bottle with 25 mL of sample.



5. Add one TPTZ Iron Reagent Powder Pillow. Immediately swirl to mix.



6. Wait 3 minutes. A blue color develops.

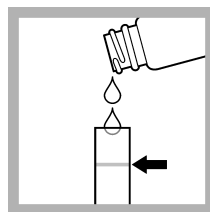

7. Fill a second tube to the top line with the prepared sample.

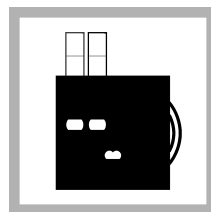

8. Put the second tube into the color comparator box.

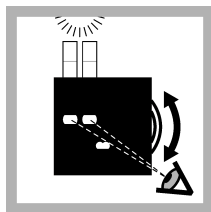

9. Hold the color comparator box below a light source. Turn the color disc to find the color match.

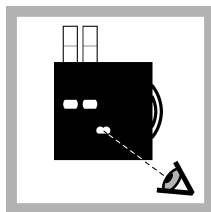

10. Read the result in mg/L in the scale window.

## Test procedure—Iron (0–2 mg/L Fe)

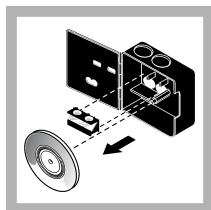

1. If installed, remove the long-path adapter.

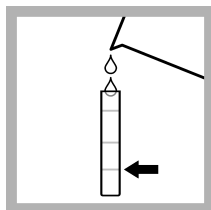

2. Fill a tube to the first line (5 mL) with sample.

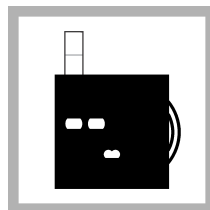

3. Put the tube into the left opening of the color comparator box.

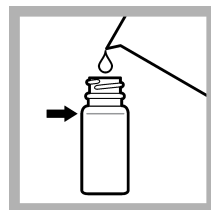

4. Fill a bottle with 25 mL of sample.



5. Add one TPTZ Iron Reagent Powder Pillow. Immediately swirl to mix.



6. Wait 3 minutes. A blue color develops.

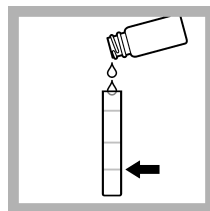

7. Fill a second tube to the first line (5 mL) with the prepared sample.

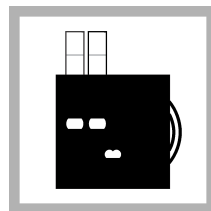

8. Put the second tube into the color comparator box.

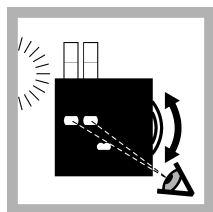

**9.** Hold the color comparator box in front of a light source. Turn the color disc to find the color match.

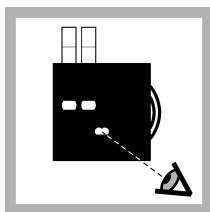

**10.** Read the result in mg/L in the scale window.

## Interferences

Interferences were tested with an iron concentration of 0.5 mg/L Fe. The following do not interfere with this method when present up to the levels shown.

Interfering substance	Interference level
Cadmium	4.0 mg/L
Chromium <sup>3+</sup>	0.25 mg/L
Chromium <sup>6+</sup>	1.2 mg/L
Cobalt	0.05 mg/L
Copper	0.6 mg/L
Cyanide	2.8 mg/L
Manganese	50.0 mg/L
Mercury	0.4 mg/L
Molybdenum	4.0 mg/L
Nickel	1.0 mg/L
Nitrite Ion	0.8 mg/L

## Replacement items

**Note:** Product and Article numbers may vary for some selling regions. Contact the appropriate distributor or refer to the company website for contact information.

Description	Unit	Item no.
TPTZ Iron Reagent Powder Pillows, 25 mL	100/pkg	2275699
Color disc, iron, TPTZ, 0–0.2 mg/L	each	9265400
Color disc, iron, TPTZ, 0–2.0 mg/L	each	9264300
Bottle, square, 29 mL, with 10, 15, 20 and 23-mL marks	6/pkg	232706
Color comparator box	each	173200
Long-path adapter	each	2412200
Glass viewing tubes, 18 mm	6/pkg	173006
Stoppers for 18-mm glass tubes and AccuVac Ampuls	6/pkg	173106

## Optional items

Description	Unit	Item no.
Hydrochloric acid standard solution, 6.0 N (1:1)	500 mL	88449
Iron standard solution, 1 mg/L Fe	500 mL	13949
Sodium hydroxide standard solution, 1.0 N	100 mL MDB	104532
Sulfuric acid standard solution, 1.0 N	100 mL MDB	127032
Water, deionized	500 mL	27249

# Nitrite

## Test preparation

### ⚠ CAUTION

Review the Safety Data Sheets (MSDS/SDS) for the chemicals that are used. Use the recommended personal protective equipment.

- Put the color disc on the center pin in the color comparator box (numbers to the front).
- Use sunlight or a lamp as a light source to find the color match with the color comparator box.
- Rinse the tubes with sample before the test. Rinse the tubes with deionized water after the test.
- If the color match is between two segments, use the value that is in the middle of the two segments.
- If the color disc becomes wet internally, pull apart the flat plastic sides to open the color disc. Remove the thin inner disc. Dry all parts with a soft cloth. Assemble when fully dry.
- Undissolved reagent does not have an effect on test accuracy.
- To record the test result as mg/L  $\text{NaNO}_2$ , multiply the test result by 1.5.
- To record the test result as mg/L N, multiply the test result by 0.3.

## Test procedure—Nitrite (0–80 mg/L $\text{NO}_2^-$ )

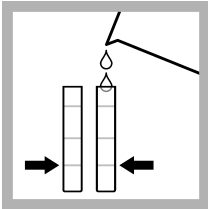

1. Fill two tubes to the first line (5 mL) with sample.

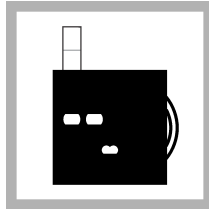

2. Put one tube into the left opening of the color comparator box.

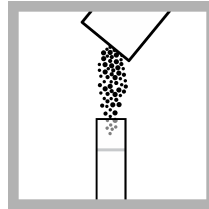

3. Add one NitriVer 2 Reagent Powder Pillow to the second tube.

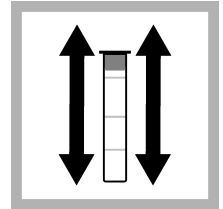

4. Put the stopper on the second tube. Shake to mix.



5. Wait 5 minutes. A green-brown color develops.

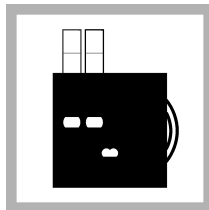

6. Put the second tube into the color comparator box.

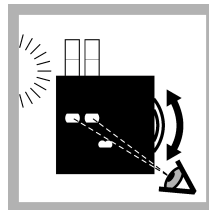

7. Hold the color comparator box in front of a light source. Turn the color disc to find the color match.

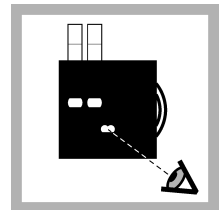

8. Read the result in mg/L in the scale window.

## Test procedure—Nitrite (0–1600 mg/L NO<sub>2</sub><sup>-</sup>)

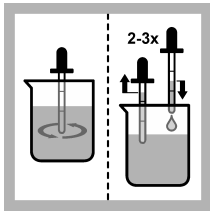

1. Fully rinse the dropper with the sample.

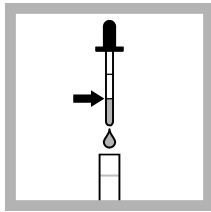

2. Use the dropper to add 0.5-mL of sample to one tube.

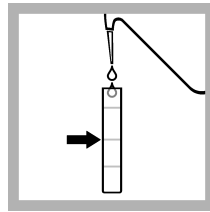

3. Fill the tube to the second line (10 mL) with deionized water.

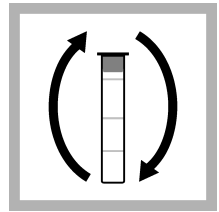

4. Put the stopper on the tube. Invert to mix.

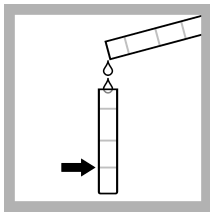

5. Pour 5 mL of the diluted sample into another tube.

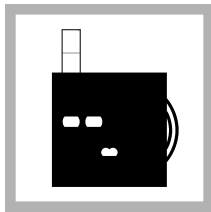

6. Put one tube into the left opening of the color comparator box.

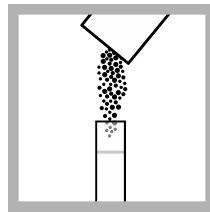

7. Add one NitriVer 2 Reagent Powder Pillow to the second tube.

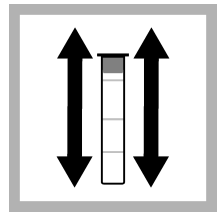

8. Put the stopper on the second tube. Shake to mix.



9. Wait 5 minutes. A green-brown color develops.

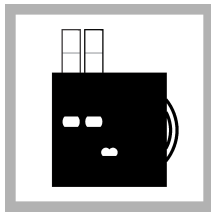

10. Put the second tube into the color comparator box.

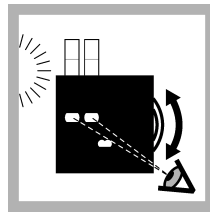

11. Hold the color comparator box in front of a light source. Turn the color disc to find the color match.

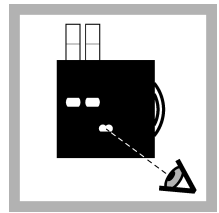

12. Read the value in the scale window.

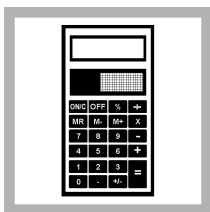

13. Multiply the value by 20 to get the result in mg/L.



## Replacement items

Description	Unit	Item no.
NitriVer 2 Nitrite Reagent Powder Pillows, 5 mL	100/pkg	181369
Color disc, nitrite, 0–80 mg/L, 0–1600 mg/L	each	9262900
Color comparator box	each	173200
Dropper, glass, 0.5- and 1.0-mL marks	5/pkg	1419705
Glass viewing tubes, 18 mm	6/pkg	173006
Stoppers for 18-mm glass tubes and AccuVac Ampuls	6/pkg	173106

## Optional items

Description	Unit	Item no.
Water, deionized	500 mL	27249

# pH

## Test preparation

### ⚠ CAUTION

Review the Safety Data Sheets (MSDS/SDS) for the chemicals that are used. Use the recommended personal protective equipment.

- Put the color disc on the center pin in the color comparator box (numbers to the front).
- Use sunlight or a lamp as a light source to find the color match with the color comparator box.
- Rinse the tubes with sample before the test. Rinse the tubes with deionized water after the test.
- If the color match is between two segments, use the value that is in the middle of the two segments.
- If the color disc becomes wet internally, pull apart the flat plastic sides to open the color disc. Remove the thin inner disc. Dry all parts with a soft cloth. Assemble when fully dry.
- To verify the test accuracy, use a buffer solution as the sample.
- More than 1 mg/L chlorine interferes with the test. To remove chlorine from the sample, add 1 drop of 0.1 N sodium thiosulfate solution to 25 mL of sample and mix. Use this dechlorinated sample in the test procedure. The sodium thiosulfate removes a maximum of 10 mg/L chlorine from the sample.
- The bromthymol blue test procedure, with a range of 5.6 to 8.4 pH units, gives the most accurate results in the 6.0–8.0 pH units range. For accurate results above this range, use the thymol blue test procedure, which has a range of 7.4 to 9.6 pH units.

## Test procedure—pH (5.6–8.4 pH units)

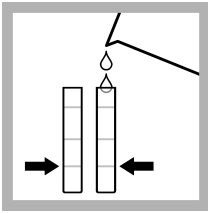

1. Fill two tubes to the first line (5 mL) with sample.

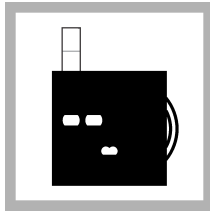

2. Put one tube into the left opening of the color comparator box.

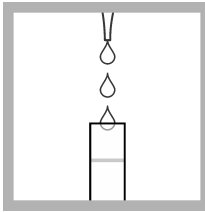

3. Add 8 drops of bromthymol blue pH indicator solution to the second tube.

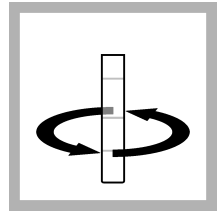

4. Swirl to mix.

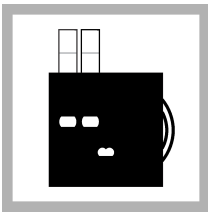

5. Put the second tube into the color comparator box.

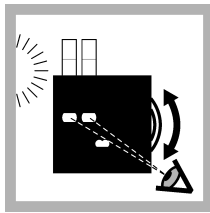

6. Hold the color comparator box in front of a light source. Turn the color disc to find the color match.

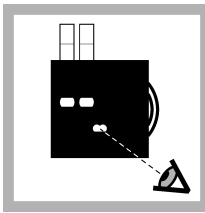

7. Read the result in pH units in the scale window.

## Test procedure—pH (7.4–9.6 pH units)

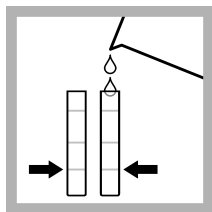

1. Fill two tubes to the first line (5 mL) with sample.

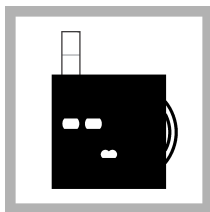

2. Put one tube into the left opening of the color comparator box.

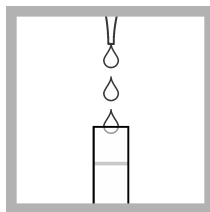

3. Add 6 drops of thymol blue pH indicator solution to the second tube.

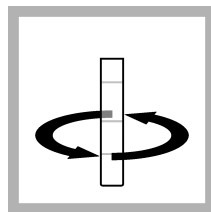

4. Swirl to mix.

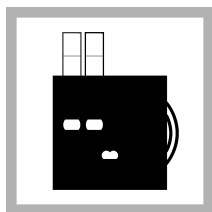

5. Put the second tube into the color comparator box.

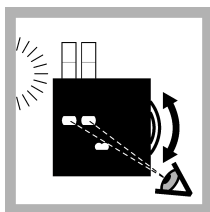

6. Hold the color comparator box in front of a light source. Turn the color disc to find the color match.

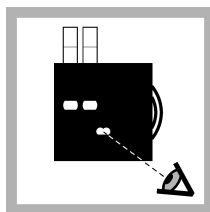

7. Read the result in pH units in the scale window.

## Replacement items

*Note: Product and Article numbers may vary for some selling regions. Contact the appropriate distributor or refer to the company website for contact information.*

Description	Unit	Item no.
Bromthymol blue pH indicator solution	100 mL MDB	25532
Thymol blue pH indicator solution	100 mL MDB	25732
Color disc, pH, bromthymol blue, 5.6–8.4 pH units	each	9261200
Color disc, pH, thymol blue, 7.4–9.6 pH units	each	9263500
Color comparator box	each	173200
Glass viewing tubes, 18 mm	6/pkg	173006
Stoppers for 18-mm glass tubes and AccuVac Ampuls	6/pkg	173106

## Optional items

Description	Unit	Item no.
pH 7.0 buffer solution, colorless	500 mL	1222249
Buffer Powder Pillows, pH 9.00 (NIST), colorless	50/pkg	1410766
Demineralizer bottle, 473-mL capacity	each	2184600

## Optional items (continued)

Description	Unit	Item no.
Sodium thiosulfate, 0.1 N	100 mL MDB	32332
Water, deionized	500 mL	27249

# Phosphate

## Test preparation

### ⚠ CAUTION

Review the Safety Data Sheets (MSDS/SDS) for the chemicals that are used. Use the recommended personal protective equipment.

- Put the color disc on the center pin in the color comparator box (numbers to the front).
- Use sunlight or a lamp as a light source to find the color match with the color comparator box.
- Rinse the tubes with sample before the test. Rinse the tubes with deionized water after the test.
- For best results, clean the tubes and bottles with 6.0 N (1:1) hydrochloric acid solution, then rinse with deionized water.
- If the color match is between two segments, use the value that is in the middle of the two segments.
- If the color disc becomes wet internally, pull apart the flat plastic sides to open the color disc. Remove the thin inner disc. Dry all parts with a soft cloth. Assemble when fully dry.
- Undissolved reagent does not have an effect on test accuracy.
- To verify the test accuracy, use a standard solution as the sample.
- Use the filtration procedure for samples that contain turbidity.
- To determine metaphosphate, use the digestion procedure to determine the total inorganic phosphate. Subtract the result of an orthophosphate test (without digestion) from the total inorganic phosphate result.
- To record the test result as mg/L P, divide the mg/L  $\text{PO}_4$  test result by 3.
- To record the test result as mg/L  $\text{P}_2\text{O}_5$ , multiply the mg/L  $\text{PO}_4$  test result by 0.75.
- Orthophosphate and condensed phosphates are used in water treatment systems to control corrosion and scale. When dissolved in water, condensed phosphates change to orthophosphate at a rate that changes with different temperature and pH conditions.

## Filtration procedure for turbid samples

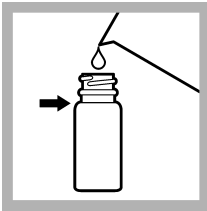

1. Fill a bottle to the shoulder with sample.



2. Add one drop of Filtration Aid Solution. Swirl to mix.

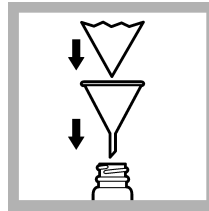

3. Put the filter paper in the funnel. Put the funnel on a second bottle.

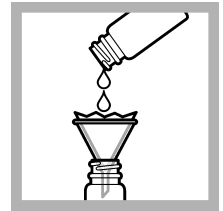

4. Pour the sample from the first bottle into the funnel.

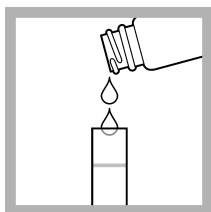

5. Use the filtered sample in the test procedure. Record the results as soluble phosphate.

## Test procedure—Orthophosphate high range (0–40 mg/L PO<sub>4</sub>)

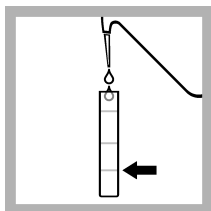

1. Fill a tube to the first line (5 mL) with deionized water.

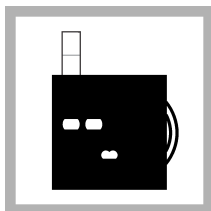

2. Put the tube into the left opening of the color comparator box.

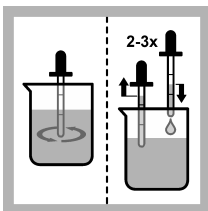

3. Fully rinse the dropper with the sample.

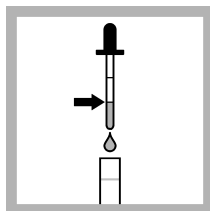

4. Use the dropper to add 0.5-mL of sample to a second tube.

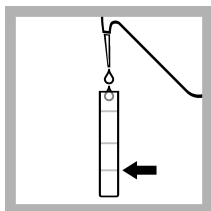

5. Add deionized water to the first line (5 mL) on the second tube.

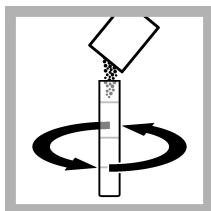

6. Add one PhosVer 3 Phosphate Reagent Powder Pillow to the second tube. Swirl to mix.



7. Wait 2 minutes. A blue color develops. Read the result within 5 minutes.

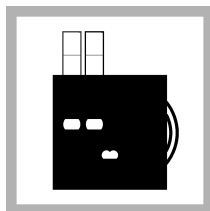

8. Put the second tube into the color comparator box.

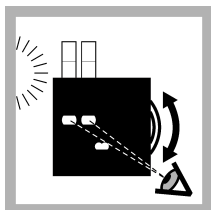

9. Hold the color comparator box in front of a light source. Turn the color disc to find the color match.

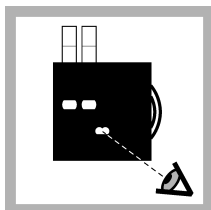

10. Read the result in mg/L in the scale window.

## Digestion procedure for total inorganic phosphate

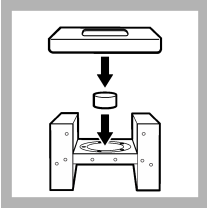

1. Assemble the heating apparatus.



2. Fill the bottle to the 20-mL mark with sample.

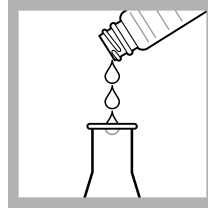

3. Pour the sample into a clean 50-mL Erlenmeyer flask.

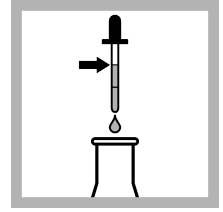

4. Use the dropper to add 2.0 mL of 5.25 N sulfuric acid.



5. Swirl to mix.

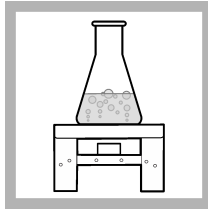

6. Put the flask on the heating apparatus.



7. Boil the solution for 10 minutes.



8. Add some deionized water during the boil time, if necessary, to keep some solution in the flask.

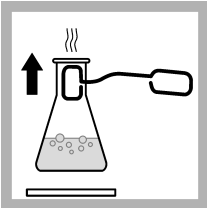

9. Use the clamp to remove the flask.

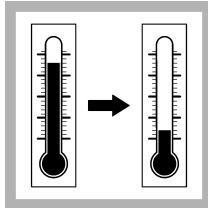

10. Wait until the solution is cool.

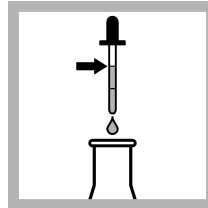

11. Use the dropper to add 2.0 mL of 5 N sodium hydroxide.



12. Swirl to mix.

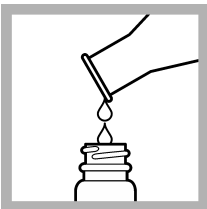

13. Pour the solution into the bottle.

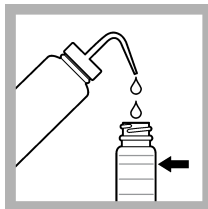

14. Add deionized water to the 20-mL mark.

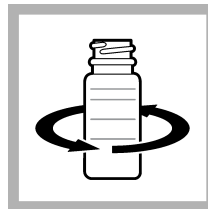

15. Swirl to mix.

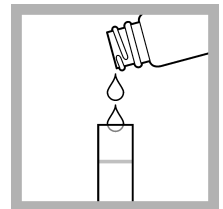

16. Use the digested sample in the test procedure. The result is total inorganic phosphate.

## Interferences

Table 11 shows the interferences and interference levels. Table 12 shows the substances that do not interfere at or below the indicated levels.

**Table 11 Interfering substances**

Interfering substance	Interference level
Arsenate	Causes a negative interference. Causes a positive interference only if the sample is heated.
Bismuth	Causes a negative interference.
Fluoride	Causes a negative interference.
Iron, ferrous	Causes a blue color which interferes at more than 100 mg/L Fe.
Molybdate	Causes a negative interference at more than 1000 mg/L.
Silica	Causes a positive interference only if the sample is heated.
Sulfide	Causes a negative interference.
Thiocyanate	Causes a negative interference.
Thiosulfate	Causes a negative interference.
Thorium	Causes a negative interference.

**Table 12 Substances that do not interfere at less than 1000 mg/L**

Substance		
Benzoate	Molybdate	Salicylate
Citrate	Oxalate	Tartrate
Formate	Pyrophosphate	Tetraborate
Lactate	Selenate	

## Replacement items

**Note:** Product and Article numbers may vary for some selling regions. Contact the appropriate distributor or refer to the company website for contact information.

Description	Unit	Item no.
PhosVer® 3 Phosphate Reagent Powder Pillows, 5 mL	100/pkg	220999
Bottle, square, 29 mL, with 10, 15, 20 and 23-mL marks	6/pkg	232706
Clamp, test tube holder	each	63400
Color comparator box	each	173200
Color disc, phosphate, 0–40 mg/L	each	9262100
Cookit stove with Heatab fuel tablets	each	220600
Cookit support cover	each	217900
Dropper, glass, 0.5- and 1.0-mL marks	5/pkg	1419705
Dropper assembly, 0.5 & 1.0 mL	6/pkg	2318506
Filter paper, 2–3 micron, pleated, 12.5 cm	100/pkg	189457
Filtration aid solution, 29-mL dropper bottle	29 mL	104633



## Replacement items (continued)

Description	Unit	Item no.
Flask, Erlenmeyer, 50 mL	each	50541
Funnel, poly, 65 mm	each	108367
Glass viewing tubes, 18 mm	6/pkg	173006
Heatab dry fuel tablets for Cookit stove	21/pkg	220700
Sodium hydroxide standard solution, 5.0 N	100 mL MDB	245032
Stoppers for 18-mm glass tubes and AccuVac Ampuls	6/pkg	173106
Sulfuric acid standard solution, 5.25 N	100 mL MDB	244932

## Optional items

Description	Unit	Item no.
Boiling chips, carbon	227 g	1483531
Demineralizer bottle, 473-mL capacity	each	2184600
Hydrochloric acid standard solution, 6.0 N (1:1)	500 mL	88449
Phosphate standard solution, 30 mg/L as PO <sub>4</sub> (NIST)	946 mL	1436716
Sodium hydroxide standard solution, 5.0 N	1 L	245053
Sulfuric acid standard solution, 5.25 N	1 L	244953
Water, deionized	500 mL	27249

# Silica

## Test preparation

### ⚠ CAUTION

Review the Safety Data Sheets (MSDS/SDS) for the chemicals that are used. Use the recommended personal protective equipment.

- Put the color disc on the center pin in the color comparator box (numbers to the front).
- Use sunlight or a lamp as a light source to find the color match with the color comparator box.
- Rinse the tubes with sample before the test. Rinse the tubes with deionized water after the test.
- If the color match is between two segments, use the value that is in the middle of the two segments.
- If the color disc becomes wet internally, pull apart the flat plastic sides to open the color disc. Remove the thin inner disc. Dry all parts with a soft cloth. Assemble when fully dry.
- Undissolved reagent does not have an effect on test accuracy.
- To verify the test accuracy, use a standard solution as the sample.
- The sample temperature must be 15–25 °C (59–77 °F) for accurate results.
- Phosphate levels of more than 50 mg/L  $\text{PO}_4^{3-}$  interfere with the 0–30 mg/L test procedure. If 60 mg/L  $\text{PO}_4^{3-}$  is in the sample, the error is –2% silica . If 75 mg/L  $\text{PO}_4^{3-}$  is in the sample, the error is –11% silica . Use the high range test procedure if high levels of phosphate are in the sample.
- Silica in boiler and cooling water forms a hard, dense layer on surfaces that cannot be easily removed, which decreases the efficiency of the system.

## Test procedure—Silica (0–30 mg/L $\text{SiO}_2$ )

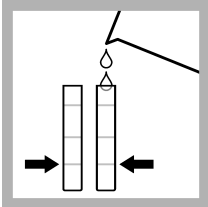

1. Fill two tubes to the first line (5 mL) with sample.

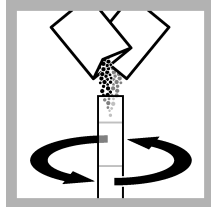

2. Add one Acid Reagent Powder Pillow and one Molybdate Reagent Powder Pillow to one tube. Swirl to mix.



3. Wait 10 minutes. A yellow color develops if silica or phosphate is in the sample.

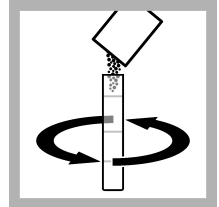

4. Add one Citric Acid Powder Pillow to the same tube. Swirl to mix.



**5.** Wait 2 minutes. Interference from phosphate is removed.

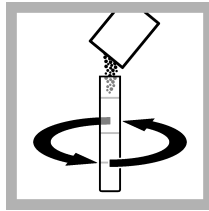

**6.** Add one Silica 3 Reagent Powder Pillow to the same tube. Swirl to mix.



**7.** Wait 5 minutes. A blue color develops if silica is in the sample.

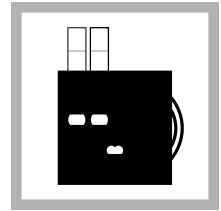

**8.** Put the blank tube into the left opening of the color comparator box. Put the prepared sample tube into the color comparator box.

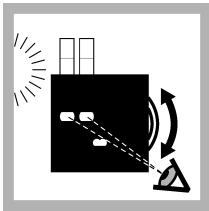

**9.** Hold the color comparator box in front of a light source. Turn the color disc to find the color match.

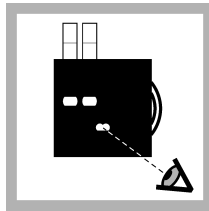

**10.** Read the result in mg/L in the scale window.

## Test procedure—Silica (0–300 mg/L SiO<sub>2</sub>)



**1.** Use the dropper to add 1 mL of sample to the bottle.



**2.** Fill the bottle to the 10-mL mark with deionized water. Swirl to mix.

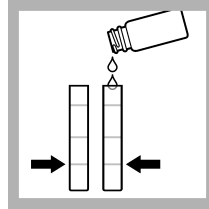

**3.** Fill two tubes to the first line (5 mL) with the diluted sample.

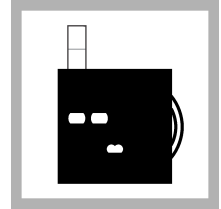

**4.** Put one tube into the left opening of the color comparator box.

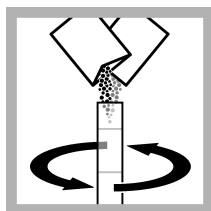

5. Add one Acid Reagent Powder Pillow and one Molybdate Reagent Powder Pillow to the second tube. Swirl to mix.



6. Wait 10 minutes. A yellow color develops if silica or phosphate is in the sample.

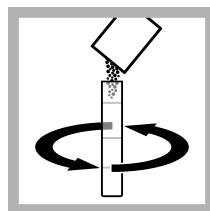

7. Add one Citric Acid Powder Pillow to the same tube. Swirl to mix.

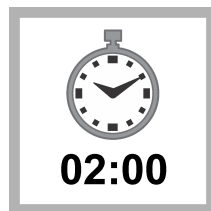

8. Wait 2 minutes. Interference from phosphate is removed.

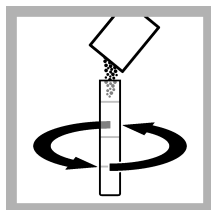

9. Add one Silica 3 Reagent Powder Pillow to the same tube. Swirl to mix.

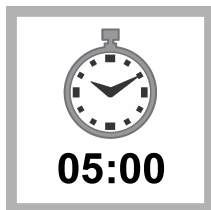

10. Wait 5 minutes. A blue color develops if silica is in the sample.

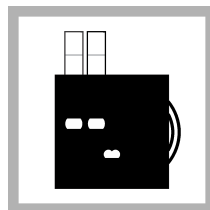

11. Put the second tube into the color comparator box.

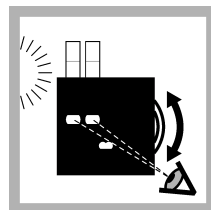

12. Hold the color comparator box in front of a light source. Turn the color disc to find the color match.

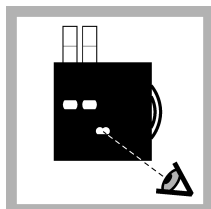

13. Read the value in the scale window.

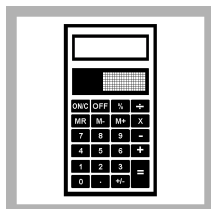

14. Multiply the value by 10 to get the result in mg/L.

## Replacement items

**Note:** Product and Article numbers may vary for some selling regions. Contact the appropriate distributor or refer to the company website for contact information.

Description	Unit	Item no.
Acid Reagent Powder Pillows, 5 mL	100/pkg	1454599
Citric Acid Powder Pillows, 5 mL	100/pkg	1454999
Molybdate Reagent Powder Pillows, 5 mL	100/pkg	1454699
Silica 3 Reagent Powder Pillows	100/pkg	27169
Bottle, square, 29 mL, with 10, 15, 20 and 23-mL marks	6/pkg	232706

## Replacement items (continued)

Description	Unit	Item no.
Color disc, silica, 0–30 mg/L	each	9262000
Color comparator box	each	173200
Dropper, glass, 0.5- and 1.0-mL marks	5/pkg	1419705
Glass viewing tubes, 18 mm	6/pkg	173006
Stoppers for 18-mm glass tubes and AccuVac Ampuls	6/pkg	173106

## Optional items

Description	Unit	Item no.
Demineralizer bottle, 473-mL capacity	each	2184600
Silica standard solution, 10 mg/L as SiO <sub>2</sub> (NIST)	500 mL	140349
Water, deionized	500 mL	27249

# Sulfite

## Test preparation

### ⚠ CAUTION

Review the Safety Data Sheets (MSDS/SDS) for the chemicals that are used. Use the recommended personal protective equipment.

- Analyze samples immediately after collection.
- Decrease the temperature of hot samples to 50 °C (122 °F) or less before analysis.
- Sulfite reacts quickly with oxygen in the air. Pour and mix the sample carefully during the procedure to prevent the loss of sulfite.
- Discard or clean the delivery tube immediately after use so the titrant does not dry and clog the tube. To clean, use a syringe or wash bottle to push water, then air through the tube.
- Keep the cap on the titration cartridge when not in use.
- Rinse the graduated cylinder and flask with deionized water after the test. Rinse the graduated cylinder with sample before the test.
- As an alternative to the Dissolved Oxygen 3 Reagent Powder Pillow, use 0.5 mL of 19.2 N Sulfuric Acid Standard Solution.
- To verify the test accuracy, use a standard solution as the sample. To prepare a standard solution that is equivalent to 40 mg/L sulfite, dilute 10.0 mL of a 0.025 N sodium thiosulfate standard solution to 250 mL in a volumetric flask. Use 50 mL of the standard solution as the sample in the test procedure.
- Use the conversions that follow to record the test result as a different form of sulfite.  
 $\text{mg/L Sulfite (SO}_3^{2-}) \times 1.01 = \text{Bisulfite, Hydrogen Sulfite (HSO}_3^-)$   
 $\text{mg/L Sulfite (SO}_3^{2-}) \times 1.30 = \text{Sodium Bisulfite, Sodium Hydrogen Sulfite (NaHSO}_3)$   
 $\text{mg/L Sulfite (SO}_3^{2-}) \times 2.37 = \text{Sodium Metabisulfite, Sodium Pyrosulfite (Na}_2\text{S}_2\text{O}_5)$   
 $\text{mg/L Sulfite (SO}_3^{2-}) \times 1.58 = \text{Sodium Sulfite (Na}_2\text{SO}_3)$

## Test procedure—Sulfite (mg/L SO<sub>3</sub><sup>2-</sup>)

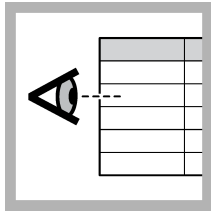

1. Select a sample volume and titration cartridge from [Table 13](#) on page 45.

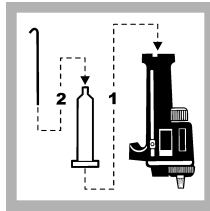

2. Attach the titration cartridge to the Digital Titrator. Insert a clean delivery tube into the cartridge.



3. Hold the Digital Titrator with the cartridge tip up. Turn the delivery knob to eject air and a few drops of titrant. Reset the counter to zero and wipe the tip.

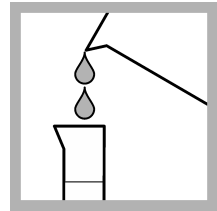

4. Use a graduated cylinder to measure the sample volume from [Table 13](#) on page 45.



5. Pour the sample into a clean, 125-mL Erlenmeyer flask.

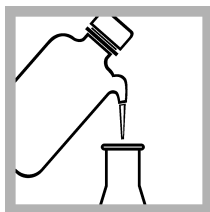

6. If the sample volume is less than 50 mL, dilute to approximately 50 mL with deionized water.

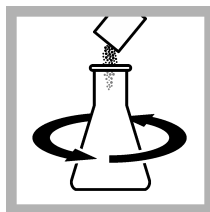

7. Add one Dissolved Oxygen 3 Reagent Powder Pillow. Swirl to mix.

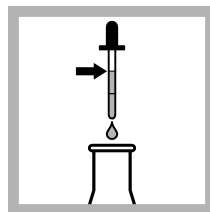

8. Add one full dropper of Starch Indicator Solution. Swirl to mix.

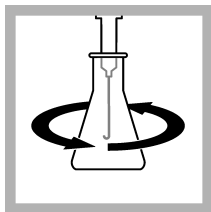

9. Put the end of the delivery tube fully into the solution. Swirl the flask.

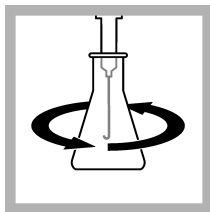

10. Turn the knob on the Digital Titrator to add titrant to the solution. Continue to swirl the flask. Add titrant until the color changes to blue.

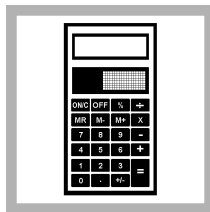

11. Record the number of digits on the counter. Use the digit multiplier in [Table 13](#) on page 45 to calculate the concentration. Digits used x digit multiplier = mg/L sulfite.

## Sample volumes and digit multipliers

Use an approximate sulfite concentration (as mg/L  $\text{SO}_3^{2-}$ ) to find the sample volume from [Table 13](#). Use the digit multiplier to calculate the concentration at the end of the test procedure.

**Table 13 Sample volumes and digit multipliers**

Range (mg/L as $\text{SO}_3^{2-}$ )	Sample volume (mL)	Titration cartridge	Digit multiplier
up to 160	50	0.3998 N $\text{KIO}_3$ -KI	0.4
100-400	20	0.3998 N $\text{KIO}_3$ -KI	1
200-800	10	0.3998 N $\text{KIO}_3$ -KI	2

## Interferences

[Table 14](#) shows the substances that can interfere with this test.

**Table 14 Interferences**

Interfering substance	Interference level
Metals	Some metals, especially copper, catalyze the oxidation of sulfite to sulfate. Immediately add one Sulfamic Acid Powder Pillow or one Dissolved Oxygen 3 Powder Pillow for each liter of sample during sample collection to prevent the interference.
Nitrite	Reacts with sulfite and causes low results.
Organic compounds	Oxidizable organic compounds can cause high results.

**Table 14 Interferences (continued)**

Interfering substance	Interference level
Oxidizable compounds	Cause high results.
Sulfide	Causes high results.

## Replacement items

*Note: Product and Article numbers may vary for some selling regions. Contact the appropriate distributor or refer to the company website for contact information.*

Description	Unit	Item no.
Sulfite Reagent Set (~100 tests), includes 1 each of 98799, 1496101, 34932	each	2272300
Clippers	each	96800
Cylinder, graduated, polypropylene, 10 mL	each	108138
Cylinder, graduated, polypropylene, 100 mL	each	108142
Delivery tube for Digital Titrator	5/pkg	1720500
Flask, Erlenmeyer, 125 mL	each	50543
Dissolved Oxygen 3 Reagent Powder Pillows	100/pkg	98799
Iodate-Iodide Digital Titrator Cartridge, 0.3998 N	each	1496101
Starch Indicator Solution	100 mL MDB	34932

## Optional items

Description	Unit	Item no.
Bottle, wash, polyethylene, 500 mL	each	62011
Cylinder, graduated, polypropylene, 25 mL	each	108140
Cylinder, graduated, polypropylene, 50 mL	each	108141
Deminerizer bottle, 473-mL capacity	each	2184600
Flask, volumetric, Class A, glass, 250 mL	each	1457446
Pipet, volumetric, Class A, 10 mL	each	1451538
Sodium Thiosulfate Standard Solution, stabilized, 0.0250 N	1 L	2409353
Sulfuric Acid Standard Solution, 19.2 N	100 mL MDB	203832
TitraStir® Titration Stand, 115 VAC	each	1940000
TitraStir® Titration Stand, 230 VAC	each	1940010
Delivery tube for Digital Titrator, 90-degree bend for use with TitraStir Titration Stand	5/pkg	4157800
Water, deionized	500 mL	27249



## Total dissolved solids (TDS)

TDS is a measure of the dissolved solids in water. High TDS levels (more than 500 ppm) can cause scaling problems in water pipes and heaters. High TDS levels can also cause an unsatisfactory taste in potable water. The TDS concentration in natural waters can be very different from one location to another because of the minerals and solubilities of the minerals in the locations.

The TDS tester measures the electrical current from ionized solids such as salts and minerals, then converts the electrical current to a concentration. Refer to the documentation that is supplied with the TDS tester to measure the TDS value of samples and to calibrate the TDS tester. Documentation is also available online.

**Note:** *The TDS value of water before and after the water goes through a softener does not change significantly because the hardness ions are replaced with sodium ions.*

## Optional items

Description	Unit	Item no.
Sodium chloride standard solution,, 85.47 mg/L NaCl (180 $\mu$ S/cm)	100 mL	2307542
Sodium chloride standard solution, 491 mg/L NaCl (1000 $\mu$ S/cm)	100 mL	1440042
Sodium chloride standard solution, 1000 mg/L NaCl (1990 $\mu$ S/cm)	100 mL	210542
Water, deionized	500 mL	27249







**HACH COMPANY World Headquarters**

P.O. Box 389, Loveland, CO 80539-0389 U.S.A.  
Tel. (970) 669-3050  
(800) 227-4224 (U.S.A. only)  
Fax (970) 669-2932  
orders@hach.com  
www.hach.com

**HACH LANGE GMBH**

Willstätterstraße 11  
D-40549 Düsseldorf, Germany  
Tel. +49 (0) 2 11 52 88-320  
Fax +49 (0) 2 11 52 88-210  
info-de@hach.com  
www.de.hach.com

**HACH LANGE Sàrl**

6, route de Compois  
1222 Vézenaz  
SWITZERLAND  
Tel. +41 22 594 6400  
Fax +41 22 594 6499