



Catalog Number 51250-18

# **SIGNAL OUTPUT MODULE (SOM)**

INSTRUMENT MANUAL

# Table Of Contents

---

Safety Precautions .....	3
Specifications .....	4
<b>Operation</b> .....	<b>5</b>
<b>Section 1 General Description</b> .....	<b>7</b>
1.1 Using This Instruction Manual .....	7
1.2 Device Description .....	8
1.3 Unpacking the SOM .....	8
<b>Section 2 Network Setup</b> .....	<b>9</b>
2.1 Adding a Signal Output Module to the Network .....	9
2.1.1 Removing or Replacing an SOM on the Network .....	10
2.1.2 Editing the SOM Name .....	11
2.2 Alarm to Relay Connections .....	12
2.3 Relay Settings .....	12
2.3.1 Relay Communication Loss .....	12
2.3.2 Relay Test .....	13
2.4 Recorder to Analog Output Connections .....	14
2.4.1 Connecting a Recorder Signal to an Output Device .....	14
2.5 Analog Output Settings .....	15
2.5.1 Output Trim .....	16
2.5.2 Communications Loss .....	16
2.5.3 Output Range .....	17
2.5.4 Output Test .....	17
<b>Installation/Maintenance</b> .....	<b>19</b>
<b>Section 3 Installation</b> .....	<b>21</b>
3.1 Mounting Instructions .....	21
3.1.1 Pole Mounting .....	21
3.1.2 Wall Mounting .....	22
3.1.3 Panel Mounting .....	24
3.2 SOM Power and Network Connections .....	25
3.2.1 Analog Output Connections .....	27
3.2.2 Using a Voltage Mode Device .....	29
3.2.3 Relay Connections .....	30
3.2.4 Network Terminator Adjustment .....	31
3.3 Interconnecting a New Device on the Network to an Existing SOM or AquaTrend Interface with SOM .....	33
<b>Section 4 Maintenance And Troubleshooting</b> .....	<b>35</b>
4.1 Maintenance .....	35
4.2 Troubleshooting .....	35
4.2.1 Configure LED .....	35
4.3 Unconfiguring the SOM .....	35
<b>Glossary</b> .....	<b>37</b>
<b>General Information</b> .....	<b>41</b>
Replacement Parts .....	43
How to Order .....	44
Repair Service .....	45
Limited Warranty .....	46
Certification .....	47
<b>Index</b> .....	<b>51</b>

Before attempting to unpack, set up, or operate this instrument, please read this entire manual. Pay particular attention to all warnings, cautions and notes. Failure to do so could result in serious injury to the operator or damage to the equipment.

To ensure the protection provided by this equipment is not impaired, this equipment **MUST NOT** be installed or used in any manner other than that which is specified in this manual.

## Use of Hazard Information

If multiple hazards exist, the signal word corresponding to the greatest hazard shall be used.

### **DANGER**

*Indicates a potentially or imminently hazardous situation which, if not avoided, could result in death or serious injury.*

### **CAUTION**

*Indicates a potentially hazardous situation that may result in minor or moderate injury.*

### **NOTE**

*Information that requires special emphasis.*

## Precautionary Labels

Please pay particular attention to labels and tags attached to the instrument. Personal injury or damage to the instrument could occur if not observed.

 This symbol, if noted on the instrument, references the instruction manual for operational and/or safety information.

 **3.2 SOM Power and Network Connections**

 **3.2.1 Analog Output Connections**

 **3.2.3 Relay Connections**

# Specifications

---

**Power requirements:** External power supply 12 VDC nominal  $\pm 25\%$  (10 to 28 VDC range) with peak ripple to be less than 10% of nominal

**Communications:** Echelon® fieldbus compatible; utilizes LonTalk® protocol. Maximum of 400 meters between devices with a 500 meter maximum per segment; distances in excess of 500 meters require a repeater. Up to 3 repeaters can be used for a total network length of 2000 meters.

**Current:** Less than 250 mA at 12 volts, (3 watts) worst case

**Operating humidity:** 5 to 95% relative humidity, non-condensing

**Operating temperature:** 0 to 40 °C (32 to 104 °F)

**Storage temperature:** -20 to 60 °C (-4 to 140 °F)

**Enclosure:** NEMA 4X (indoor) and IEC 529 IP66 rating

**Relays:** Two with both normally open and normally closed contacts rated maximum of 5A at 250 VAC resistive or 5A at 30VDC resistive

**Outputs:** Two current analog outputs; range either 4-20 mA or 0-20 mA (user selectable); both outputs isolated to 500 VDC; may be trimmed  $\pm 20\%$  if needed (via AquaTrend® Interface). Maximum load resistance 500 ohm.

**Dimensions:** 22.86 x 22.86 x 17.78 cm (9 x 9 x 7 in.)

**Shipping Weight:** (2 kg) 4 lb. 6 oz.



# Operation



## 1.1 Using This Instruction Manual

This manual includes setup and installation instructions for the Signal Output Module (SOM).

Read this section of the manual to become familiar with basic information about the SOM. A glossary of terms is provided on [page 37](#) to aid in understanding the AquaTrend® Network System.

Once you have gathered the basic information about the SOM, read all instructions and warnings in [Section 3 on page 21](#) associated with the installation of the SOM. Then refer to [section 3.1](#) for instructions on how to mount the SOM to a wall, pole, or panel.

Carefully read and follow the instructions in [section 3.2 on page 25](#) to make electrical and network connections. Then follow the instructions in [Section 2 on page 9](#) to add the SOM to the network, and setup the appropriate dialogue between the AquaTrend Interface, SOM, and sensors.

[Figure 1](#) describes the basic installation sequence for this AquaTrend Network devices and references sections of this manual where instructions are found.

**Figure 1**      **General Installation Information**

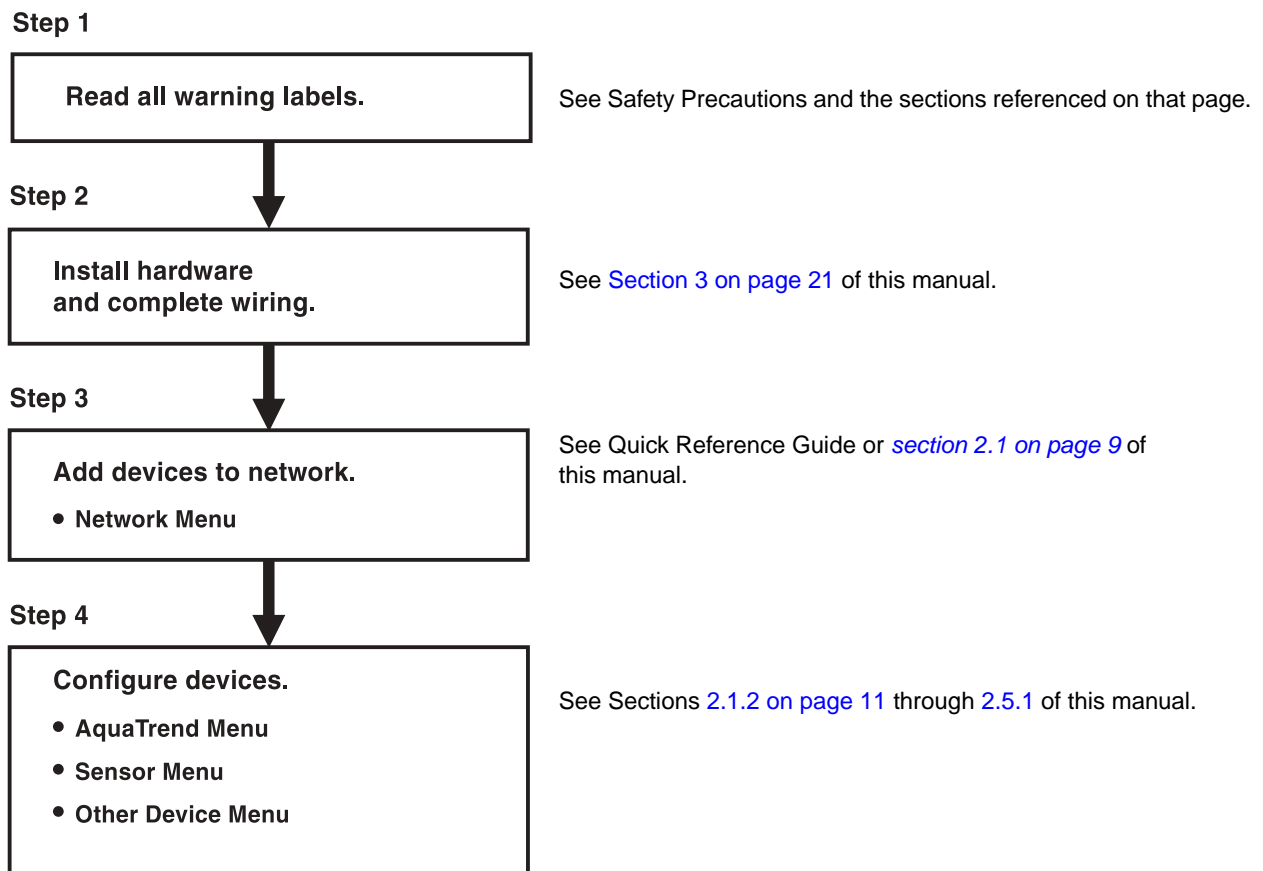

## 1.2 Device Description

The AquaTrend Signal Output Module (SOM) is designed to be used with the AquaTrend Network System. The SOM can be a stand-alone device, or it can be part of an AquaTrend interface with SOM. See [Figure 2](#).

The SOM provides two relays, each with normally open and normally closed contacts rated at a maximum of 5A/250 VAC (30 VDC, 5A) resistive loads, and two analog outputs, selectable at either 4-20 or 0-20 mA using the AquaTrend Interface.

Sensors on the AquaTrend Network System contain alarms that can be configured to trigger one of the relays in an SOM. Similarly, a recorder or controller signal from a sensor can be attached to one of the analog outputs in an SOM. This approach provides flexibility as to where the SOM can be mounted. In some cases, the SOM can be placed up to 400 m (1300 ft.) away from other devices on the network without a repeater.

The module housing, constructed of corrosion resistant materials, is designed to meet NEMA 4X (indoor)/IEC529 IP66 industrial enclosure requirements.

**Figure 2 Signal Output Module and AquaTrend Interface/SOM**

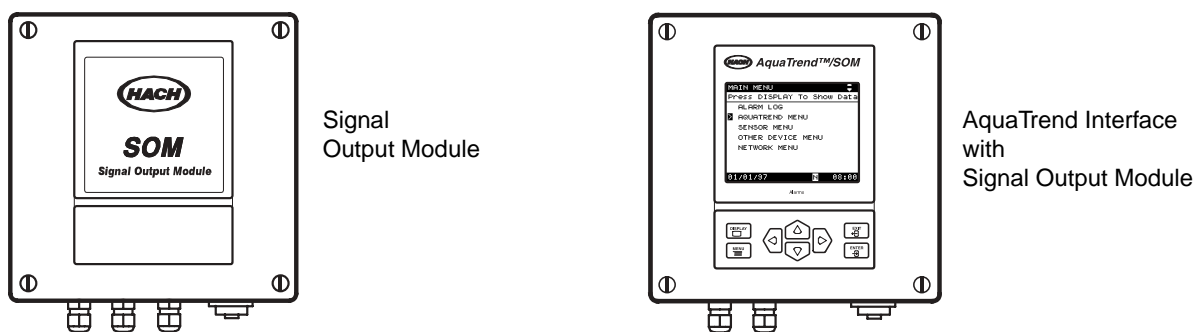

## 1.3 Unpacking the SOM

After opening the packing carton, remove the insulating foam and identify the device you have received as a Signal Output Module (SOM). If you have received this manual with the AquaTrend/SOM, refer to the AquaTrend Network System Manual for unpacking instructions. The stand-alone SOM carton should contain the items listed in [Table 1](#).

Remove the device from the carton and verify that no visible damage has occurred during shipment. Inspect the carton for the following items. Contact Hach Customer Service at 1-800-227-4224 if any items are missing or damaged. Outside the United States, contact your nearest Hach dealer.

**Table 1 Items Packaged with the Signal Output Module (SOM)**

Item	Catalog Number
Signal Output Module (SOM)	51250-60
Bracket, Wall Mount	51409-00
Cable Termination Kit	52156-00
Instruction Manual	51250-18



The following instructions apply to the stand-alone Signal Output Module (SOM) and to the SOM within the AquaTrend® Interface/SOM.

All wiring and installation (see Section 3.2) must be completed correctly so the AquaTrend Interface can recognize the SOM as an active network device. Reference the Sensor Manual and the PS1201 Manual for additional hardware wiring instructions for connecting to those devices. After wiring is complete, proceed with Section 2.1 to add an SOM to the network.

## 2.1 Adding a Signal Output Module to the Network

1. Press the **MENU** key to access the Main Menu.
2. Use the up or down arrow key to move the pointer to **NETWORK MENU** and press **ENTER**.
3. Select **Add Device** and press **ENTER**. A pop-up box will show: **SEARCHING FOR UNCONFIGURED DEVICES...PLEASE WAIT**.
  - If only one unconfigured device is found on the network, go to step 4.
  - If two or more types of unconfigured devices are listed, select **OUTPUTS** from the list and press **ENTER**.
  - If more than one SOM is configured on the network, a pop-up box will ask you to press the configure button on the device you want to add. See *Figure 15* on page 36 for the location of the configure button. Press the configure button and continue.

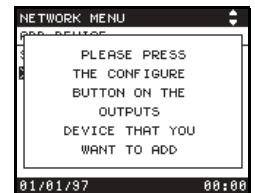
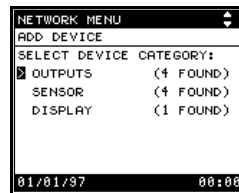
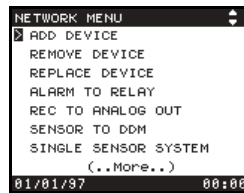
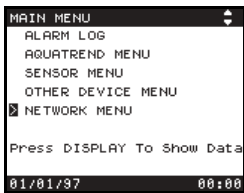

4. Select **Add Device** and press **ENTER** to continue, or select **Cancel** to cancel the operation.
5. The AquaTrend Interface will give the SOM a unique name. To change the name, refer to [section 2.1.2](#).

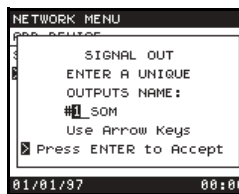
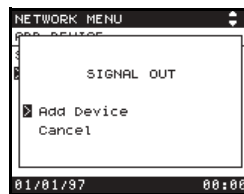

6. Press **ENTER** to accept the displayed name. Proceed with Section 2.2 to configure sensor alarms to the SOM relays.

### 2.1.1 Removing or Replacing an SOM on the Network

The remove device procedure is used to disconnect a device from the network. The replace device procedure is used to substitute an existing device with an identical new device. The replace device procedure replaces (transfers) network connections and the SOM name, but not device specific settings.

#### 2.1.1.1 Removing an SOM from the Network

Before physically removing an SOM from the system, this remove device software procedure must be performed. This assures that all network communications associated with the SOM are properly removed to avoid miscommunication from other devices on the network. Proceed as follows:

1. Press the **MENU** key to access the main menu.
2. Use the up or down arrow key to move the pointer to **NETWORK MENU** and press **ENTER**.
3. Select **REMOVE Device** and press **ENTER**.
4. From the list of device categories, select **OUTPUTS** and press **ENTER**.

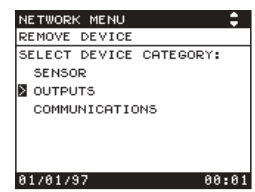
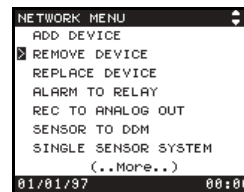

5. Select the specific SOM to remove and press the **ENTER** key.
6. Press **ENTER** again to verify the removal of the SOM or move the pointer to **Cancel** to end the operation without changes.

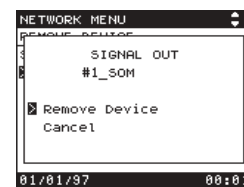
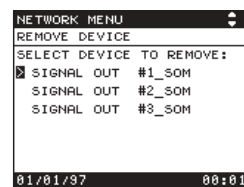

#### 2.1.1.2 Replacing an SOM on the Network

Use this procedure when you want to transfer the settings of one Signal Output Module to another. This procedure works best if both modules are physically connected to the network. If not, use the **REMOVE DEVICE** procedure to remove the current Signal Output Module, then physically unplug it from the network and use the **ADD DEVICE** to add the new module (after physically plugging it into the network). If the first module already has been physically unplugged from the network, and the **REMOVE DEVICE** procedure was not used, it will need to be unconfigured before it can be used again (see [section 4.3, Unconfiguring the SOM on page 35](#)).

This option will take you through all the steps necessary for completely removing the Signal Output Module and adding a new module—with the

settings and sensor assignment of the original module—to the network as in [section 2.1, Adding a Signal Output Module to the Network on page 9](#).

1. Press the **MENU** key to start from the AquaTrend **MAIN MENU**.
2. Select **NETWORK MENU**. Press **ENTER**.

Select **REPLACE DEVICE**. Press **ENTER**. The AquaTrend Interface will prompt you as necessary.

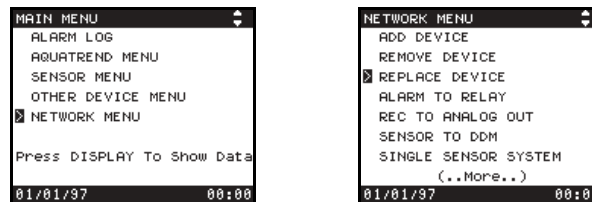

### 2.1.2 Editing the SOM Name

To change the name of an SOM on the network, follow the steps below:

1. Press the **MENU** key to access the main menu.
2. Use the up or down arrow key to move the pointer to **OTHER DEVICE MENU** and press **ENTER**.
3. If necessary, select **OUTpUTS MODULE** from the **other device menu** and press **ENTER**. A list of SOMs on the network will appear.
4. Select the SOM of interest and press **ENTER**.

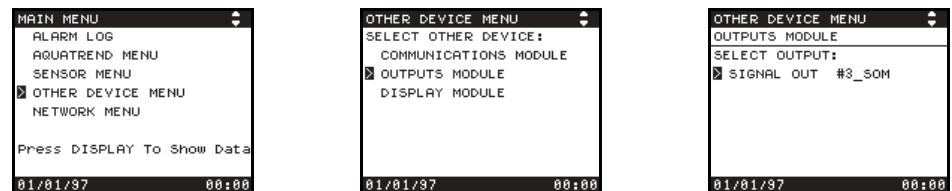

5. Select **EDIT NAME** and press **ENTER**.
6. Use the **ARROW** keys (right or left arrows to move to another character space in the name and up or down arrows to scroll through the available characters) to create a unique device name of up to 12 characters. Press **ENTER** to accept the name.
7. Press **ENTER** to confirm the name, or press **EXIT** to cancel.

**Note:** The first character of the name must not be a number.

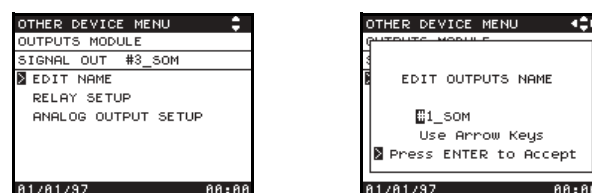

### 2.2 Alarm to Relay Connections

After the alarm settings are established as described in the Sensor Manual, the alarms must be attached to physical relays in an SOM (via the AquaTrend Interface menu). SOMs contain two relays and two analog outputs.

To attach an alarm to a relay, proceed as follows:

1. Press the **MENU** key to access the Main Menu.
2. Move the pointer to **NETWORK MENU** and press the **ENTER** key.
3. Move the pointer to **ALARM TO RELAY** and press the **ENTER** key.
4. Select **ATTACH** or **DETACH** and press **ENTER**.

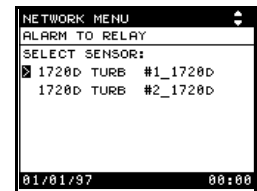
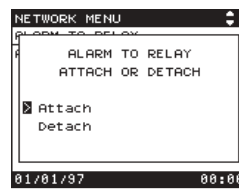
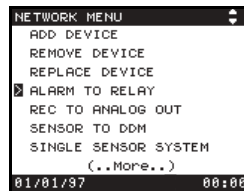

5. Select the sensor with the alarm of interest and press the **ENTER** key.
6. Select the appropriate sensor alarm number with the up or down arrow key, and press the **ENTER** key.
7. Select the SOM containing the relay of interest and press the **ENTER** key.
8. If necessary, select the appropriate SOM relay number (1 or 2) and press the **ENTER** key.
9. A summary of the attach/detach information is displayed. Press **ENTER** to connect the alarm to the relay.

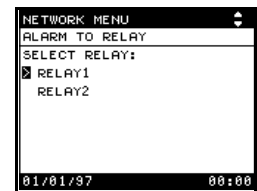
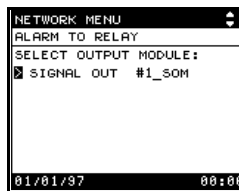
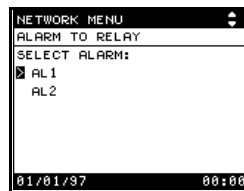

### 2.3 Relay Settings

#### 2.3.1 Relay Communication Loss

This setting tells the SOM what to do with its relays if communications with the sensors that control those relays are lost. The following steps describe how to adjust this setting:

1. Press the **MENU** key to access the main menu.
2. Use the up or down arrow key to move the pointer to **OTHER DEVICE MENU** and press **ENTER**.

3. Select **outputs module** and press **ENTER**.
  - Select the SOM of interest and press **ENTER**.
4. Select **RELAY SETUP** and press **ENTER**.
5. Select **RELAY 1** or **2** and press **ENTER**.

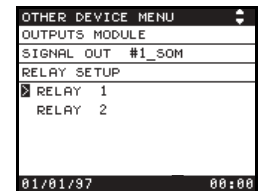
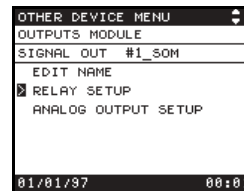

6. Select **ON COMM LOSS** and press **ENTER**.
7. Select from the following, and then press **ENTER**:
  - **Open Relay** opens the relays, regardless of their position at the time of the loss.
  - **Close Relay** closes the relays, regardless of their position at the time of the loss.
  - **Hold Current Setting** keeps the relays in the same position they were in before communication was lost.

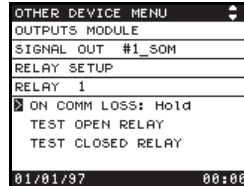

### 2.3.2 Relay Test

Test a relay to make sure it is functioning correctly by following the instructions below:

1. Press the **MENU** key to access the main menu.
2. Use the up or down arrow key to move the pointer to **OTHER DEVICE MENU** and press **ENTER**.
3. Select **outputs module** and press **ENTER**.
4. Select the SOM of interest and press **ENTER**.
5. Select **RELAY SETUP** and press **ENTER**.

6. Select **RELAY 1** or **2** and press **ENTER**.

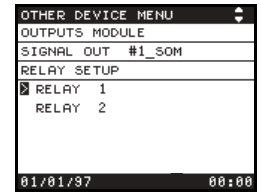
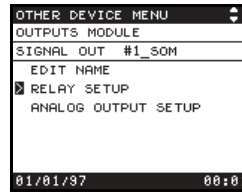

7. Select **TEST OPEN RELAY** or **TEST CLOSED RELAY**. This will open or close the specified relay for one minute or until you cancel. Press the **ENTER** key or press **EXIT** to cancel. A pop-up box will appear during the test.

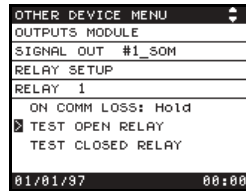

## 2.4 Recorder to Analog Output Connections

AquaTrend Interface-compatible sensors typically contain recorder signals for sending data outside the network in analog form.

After setting up parameters, recorder signals can be bound to an analog output, so 0-20 or 4-20 mA signals can be sent to a chart recorder or a Supervisory Control and Data Acquisition (SCADA) system. The AquaTrend System allows you to bind a recorder signal from a sensor to an analog output in any SOM on the network.

Analog outputs are contained in SOMs, and each SOM supplies two analog outputs.

### 2.4.1 Connecting a Recorder Signal to an Output Device

The output device must be properly configured before attempting to configure the sensor's recorder signals. Refer to [section 2.1, Adding a Signal Output Module to the Network on page 9](#) for more information.

1. Press the **MENU** key to access the Main Menu.
2. Select **NETWORK MENU** and press **ENTER**.
3. Select **RECORDER TO ANALOG OUT** and press **ENTER**.

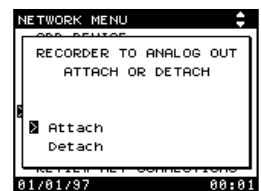
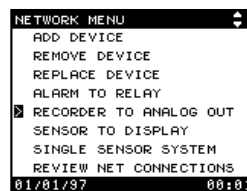

4. Select **ATTACH** and press **ENTER**.

- If only one sensor is available for relay attachment, go to step 5.
- If two or more sensors are found on the network, the AquaTrend Interface will present a list of sensors from which to choose. Select the sensor of interest and press **ENTER**
- If two or more recorders are available, a menu showing available recorders will appear. Select the recorder of interest and press **ENTER**.
- If two or more Signal Output Modules are available, select the SOM of interest and press **ENTER**.

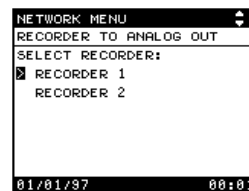
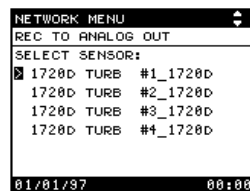

5. Select **RECORDER 1** or **RECORDER 2** and press **ENTER**.

6. A screen showing all of your selections will then appear. Select **ATTACH RECORDER TO ANALOG OUTPUT** and press **ENTER** to confirm the setting or select **CANCEL** and press **ENTER**. The message **CONFIGURING NETWORK...PLEASE WAIT** will appear.

The **OPERATION COMPLETE** message will appear when the attachment is complete.

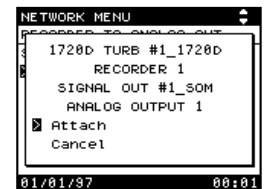
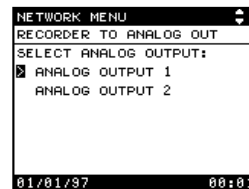
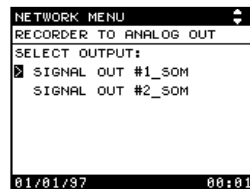

## 2.5 Analog Output Settings

The steps below explain how to access the **Analog Output Setup** Menu. From that menu, select a specific analog output and one of the following options:

- Output Trim ([Section 2.5.1](#))
- Output Test ([Section 2.5.4](#))
- Output Range ([Section 2.5.3](#))
- Communication Loss ([Section 2.5.2](#)).

1. Press the **MENU** key to access the Main Menu.

2. Use the up or down arrow key to move the pointer to **OTHER DEVICE MENU** and press **ENTER**.

3. Select **output module** and press **ENTER**.
4. Select the SOM of interest and press **ENTER**.
5. Select **ANALOG OUTPUT SETUP** and press **ENTER**.
6. Select **ANALOG OUT 1** or **2** and press **ENTER**. Then select from the options described in the next four sections.

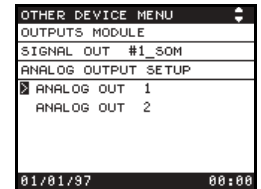
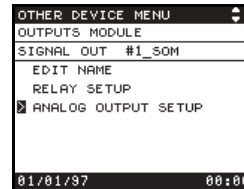

### 2.5.1 Output Trim

The trimming options provide a way to adjust the signal sent from the SOM to the output device (i.e., recorder or SCADA system). The following steps describe how this option can be adjusted:

1. Access the **Analog Output Setup Menu** using the instructions in [section 2.5](#).
2. Select **ZERO SCALE TRIM** or **FULL SCALE TRIM** to adjust the zero or full parameters and press **ENTER**. One of the following pop-up boxes will appear.
3. Use the up or down arrow key to adjust each parameter.

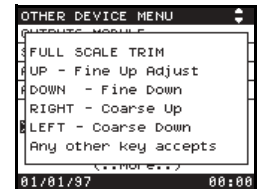
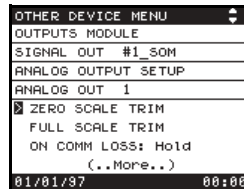

### 2.5.2 Communications Loss

If communications between the SOM and the sensor is lost, the SOM must be instructed via the software on what to do with its analog outputs. Specify these settings as follows:

1. Access the **Analog Output Setup Menu** using the instructions in [section 2.5](#).
2. Select **ON COMM LOSS**. The following menu will appear:



- Use the arrow keys to move the pointer to the appropriate selection and press **ENTER** to accept the setting.

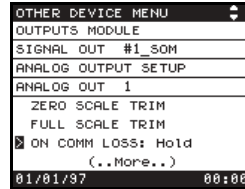

### 2.5.3 Output Range

The output range is selectable at either 0-20 or 4-20 mA. The current output range setting is shown next to the **OUTPUT RANGE** option as shown at left. To change the output range setting, proceed as follows:

- Access the **Analog Output Setup** Menu using the instructions in [section 2.5](#).
- Select **OUTPUT RANGE** and press **ENTER**.
- Select the correct output range and press **ENTER**.

**Note:** Setting an output range resets all trim levels, so if necessary, repeat [section 2.5.1](#).

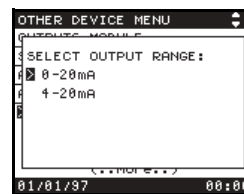
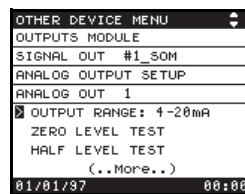

### 2.5.4 Output Test

- Access the **Analog Output Setup** Menu using the instructions in [section 2.5](#).
- Test the output to verify that the chart recorder readings match the output trim settings by selecting **ZERO**, **HALF** or **FULL level TEST** and pressing **ENTER**.
- A pop-up box will be displayed for the duration of the test. Verify that the zero, half, or full scale readings match those on the chart recorder.





## Installation/Maintenance

### **DANGER**

*Some of the following manual sections contain information in the form of warnings, cautions and notes that require special attention. Read and follow these instructions carefully to avoid personal injury and damage to the instrument. Only personnel qualified to do so, should conduct the installation/maintenance tasks described in this portion of the manual.*

### **DANGER**

*Certains des chapitres suivants de ce mode d'emploi contiennent des informations sous la forme d'avertissements, messages de prudence et notes qui demandent une attention particulière. Lire et suivre ces instructions attentivement pour éviter les risques de blessures des personnes et de détérioration de l'appareil. Les tâches d'installation et d'entretien décrites dans cette partie du mode d'emploi doivent être seulement effectuées par le personnel qualifié pour le faire.*

### **PELIGRO**

*Algunos de los capítulos del manual que presentamos contienen información muy importante en forma de alertas, notas y precauciones a tomar. Lea y siga cuidadosamente estas instrucciones a fin de evitar accidentes personales y daños al instrumento. Las tareas de instalación y mantenimiento descritas en la presente sección deberán ser efectuadas únicamente por personas debidamente cualificadas.*

### **GEFAHR**

*Einige der folgenden Abschnitte dieses Handbuchs enthalten Informationen in Form von Warnungen, Vorsichtsmaßnahmen oder Anmerkungen, die besonders beachtet werden müssen. Lesen und befolgen Sie diese Instruktionen aufmerksam, um Verletzungen von Personen oder Schäden am Gerät zu vermeiden. In diesem Abschnitt beschriebene Installations- und Wartungsaufgaben dürfen nur von qualifiziertem Personal durchgeführt werden.*

### **PERICOLO**

*Alcune parti di questo manuale contengono informazioni sotto forma d'avvertimenti, di precauzioni e di osservazioni le quali richiedono una particolare attenzione. La preghiamo di leggere attentivamente e di rispettare quelle istruzioni per evitare ogni ferita corporale e danneggiamento della macchina. Solo gli operatori qualificati per l'uso di questa macchina sono autorizzati ad effettuare le operazioni di manutenzione descritte in questa parte del manuale.*



### 3.1 Mounting Instructions

The Signal Output Module (SOM) is designed to mount easily to a wall, pole, or panel. Disassembly is not required for pole or wall mounting, and minimal disassembly is required for panel mounting. A floor stand (Cat. No. 52160-00) for setting the unit upright on a floor or table is also available.

Determine the knockouts needed for power and network wiring. Use a punch and hammer to remove those knockouts prior to mounting the SOM. Center the punch on the knockout for best results.

Figure 3 Module Dimensions

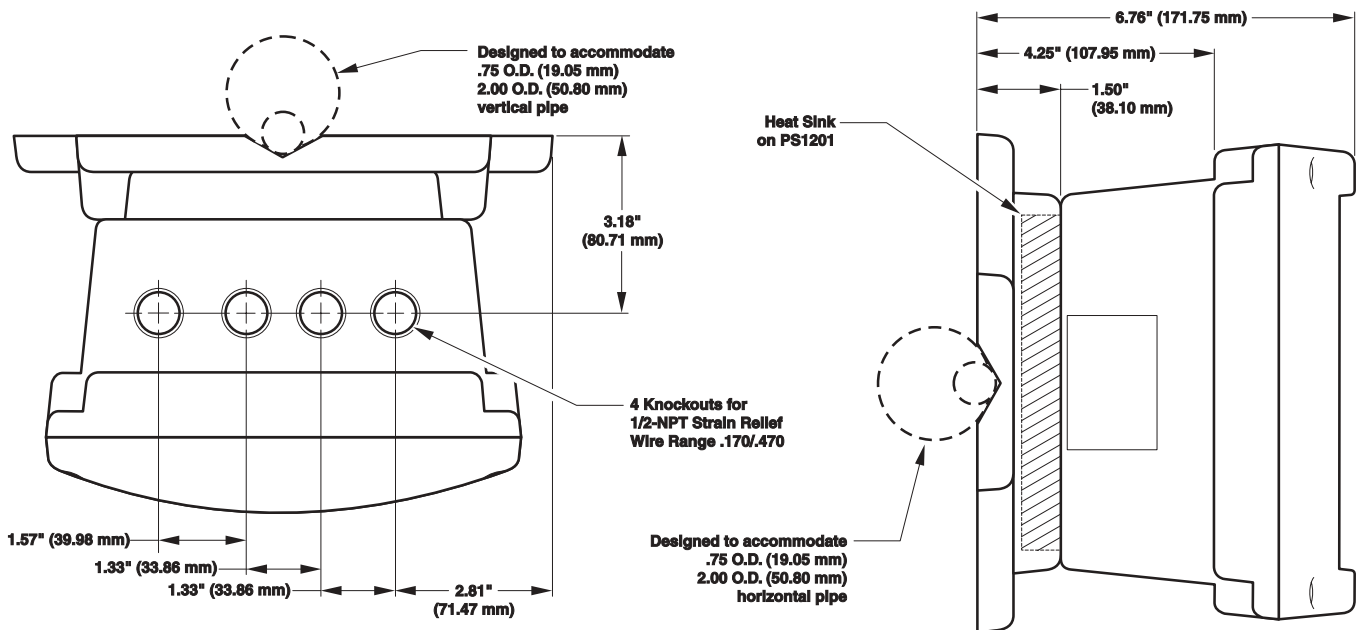

Drawing Number: 52181-00 Sheet 2  
Revision A, 1-21-98

#### 3.1.1 Pole Mounting

The mounting bracket on the back of the SOM provides an efficient way to secure the SOM to a horizontal or vertical pole (see [Figure 4](#)). Use customer-supplied U-bolts to create a channel for a 3/4- to 2-inch diameter pole. The pole must support at least five pounds. The mounting bracket need not be removed for this procedure.

1. Obtain two 1/4-20 x 2.843 U-bolts and nuts.
2. Press the back of the SOM mounting bracket against a pole in the position you want it mounted, either vertically or horizontally.
3. Place the curve of one U-bolt behind the pole, and insert the threaded ends of the bolt through two of the center holes on the mounting bracket.
4. Secure the two nuts onto the U-bolts with a wrench, and repeat steps 1-3 on the opposite end of the mounting bracket.

**Figure 4** Signal Output Module Pole Mounting

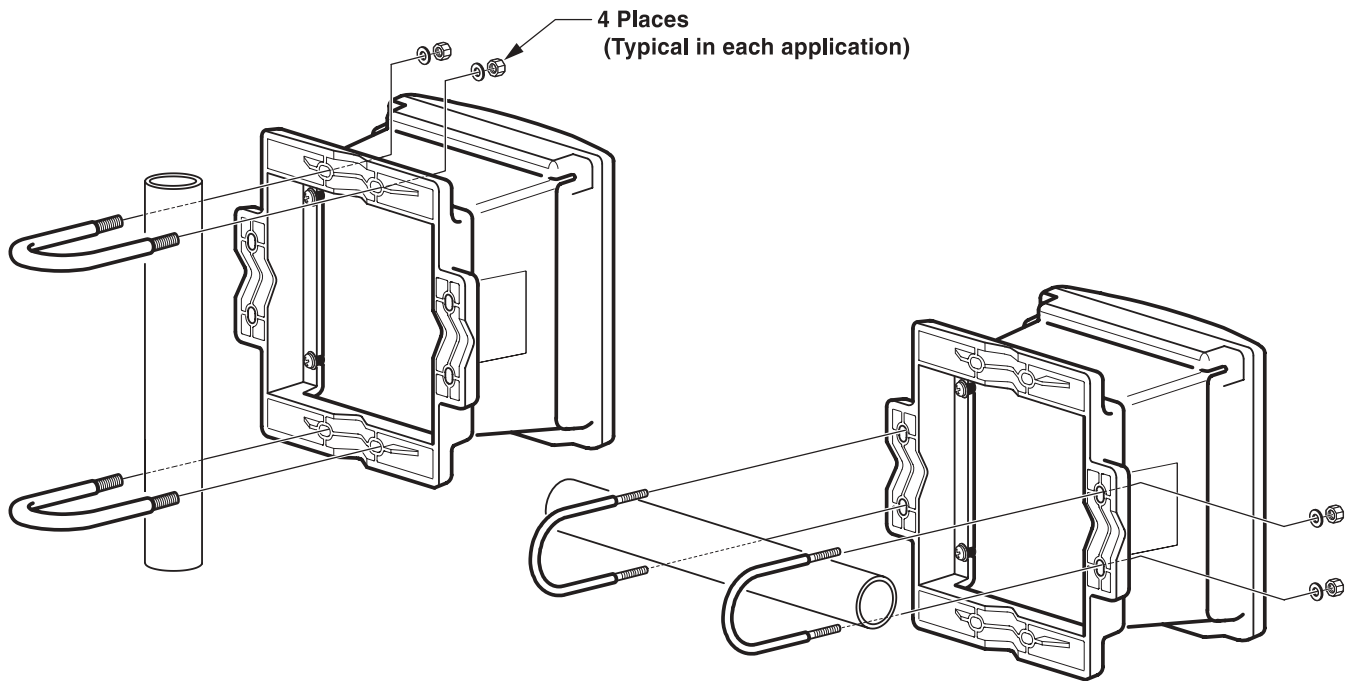

### 3.1.2 Wall Mounting

1. Remove the mounting bracket on the back of the SOM by removing the four Phillips screws on the back of the module.
2. Use the bracket as a template to mark positions on the wall for four of the eight screw holes – either the vertical or horizontal pair; or use the dimensions in [Figure 6](#).
3. Reconnect the mounting bracket to the AquaTrend (see [Figure 5](#)).
4. Drill pilot holes in the marked positions for four ¼-inch screws.
5. Use four ¼-inch hex-head or pan-head screws to secure the bracket and SOM to the wall.

Figure 5 Reconnecting the Mounting Bracket

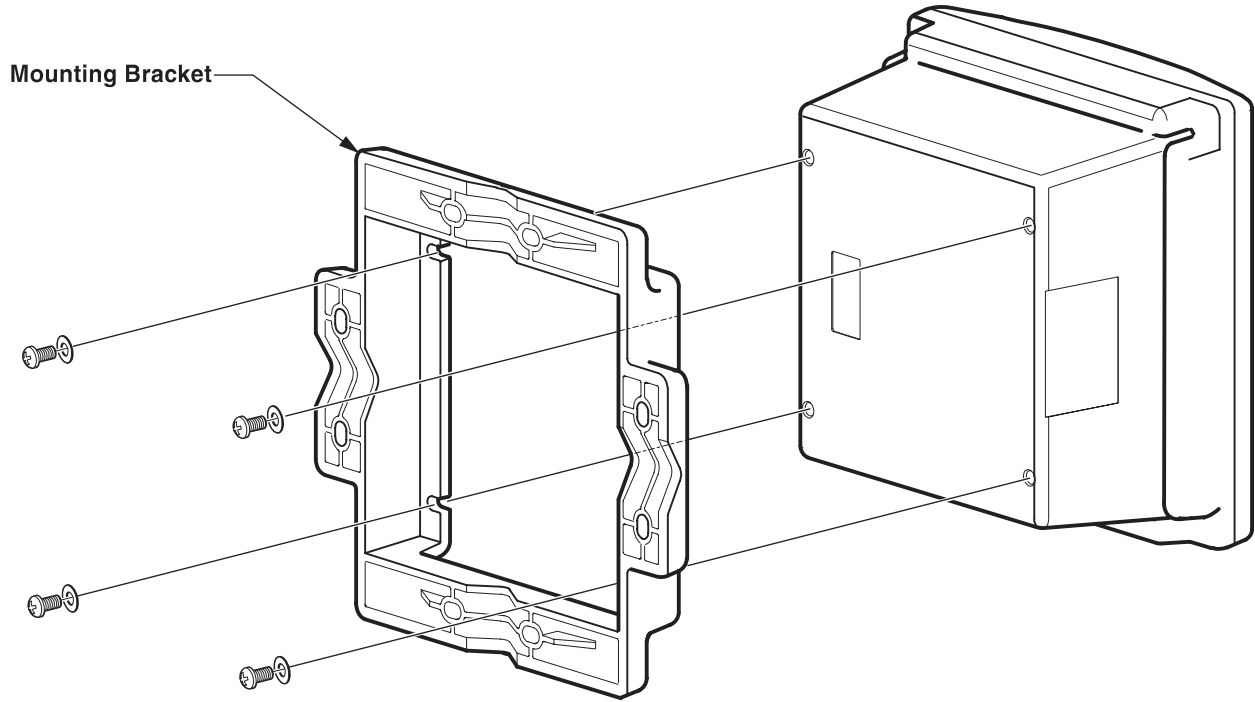
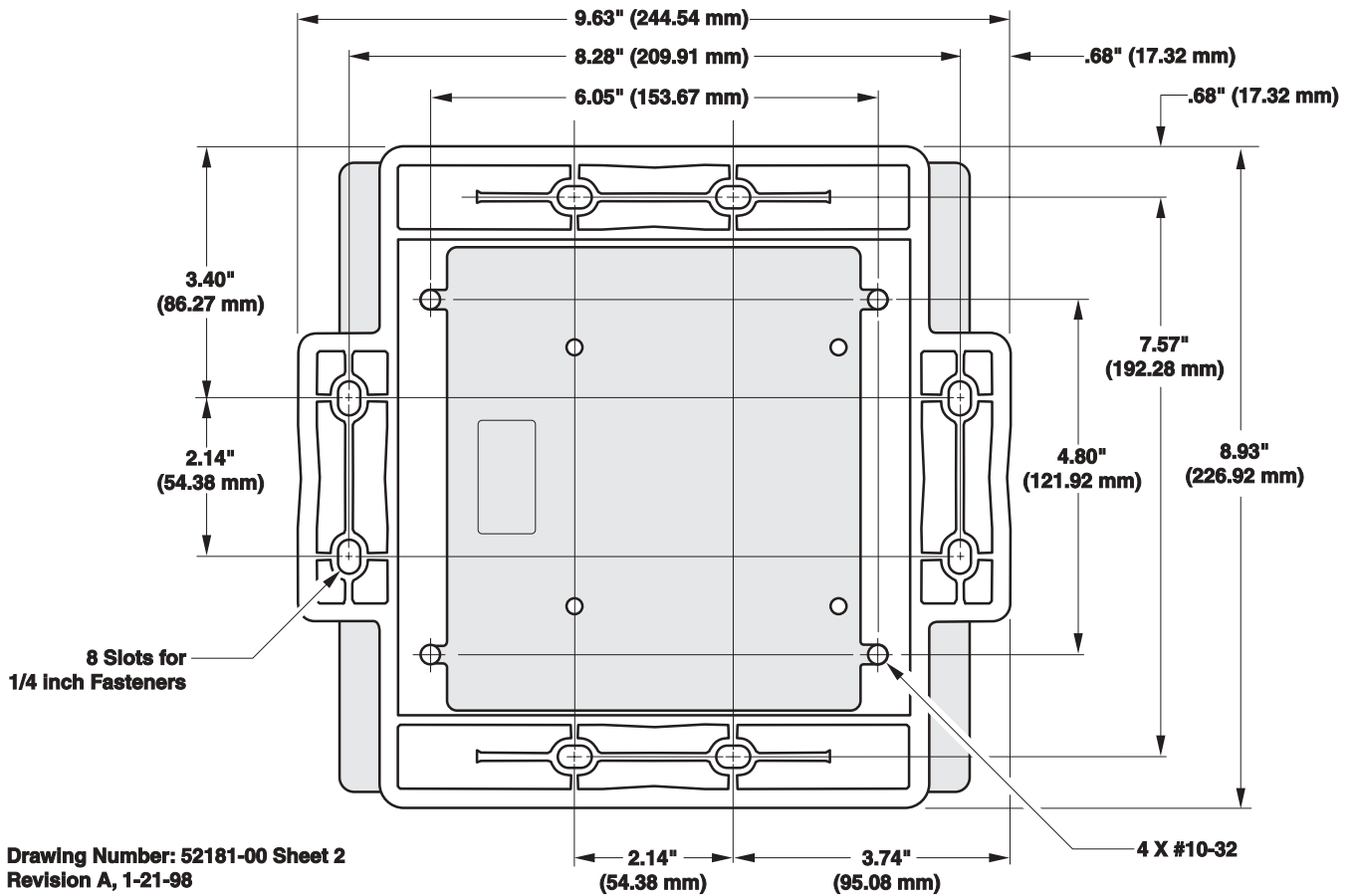

Figure 6 Signal Output Module Wall Mount Dimensions



Drawing Number: 52181-00 Sheet 2  
Revision A, 1-21-98

### 3.1.3 Panel Mounting

1. Disconnect all relay and instrument power sources, if necessary, before installation.
2. Use a Phillips screwdriver to remove the four screws holding the mounting frame onto the back of the SOM. The wall mount frame is not needed for panel mounting.
3. Use a flat-blade screwdriver to loosen the screws of the SOM face.
4. Lift the face off the SOM and set it aside. Or, store the front cover by screwing the right side of the face to the left side of the back enclosure.
5. Use a punch and hammer to remove knockouts (on the inside rim of the enclosure) needed for network or electrical wiring. Center the punch on the knockout for best results.
6. Measure the hole for the SOM by using the dimensions in [Figure 8](#). Mark the panel for placement of three #10 pan-head screws.
7. Cut out the panel hole and drill pilot holes for the three screws.
8. Fit the AquaTrend into the panel hole and secure it with three #10 pan-head screws.
9. Make wire connections as discussed in [section 3.2](#).
10. Ensure that the gasket is properly seated in the SOM face and tighten the screws (10 in-lb [1.1 n-m] maximum). Do not overtighten the screws.

**Figure 7** Panel Mounting

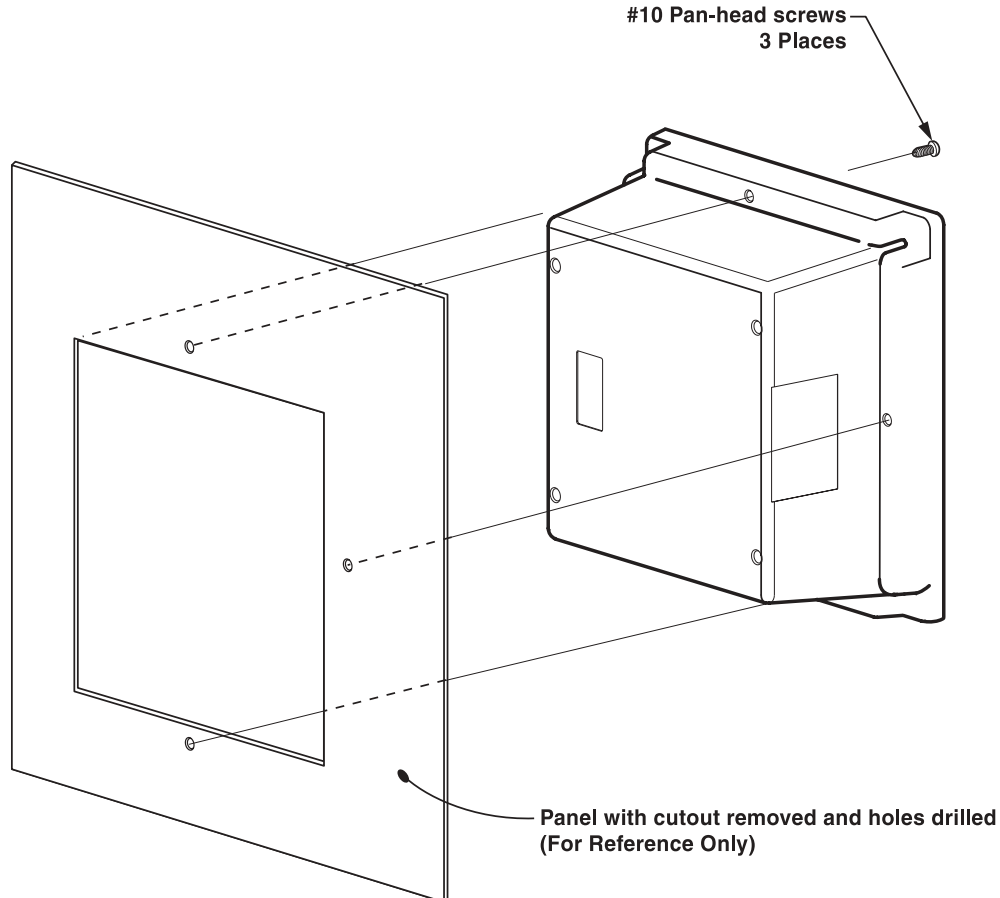
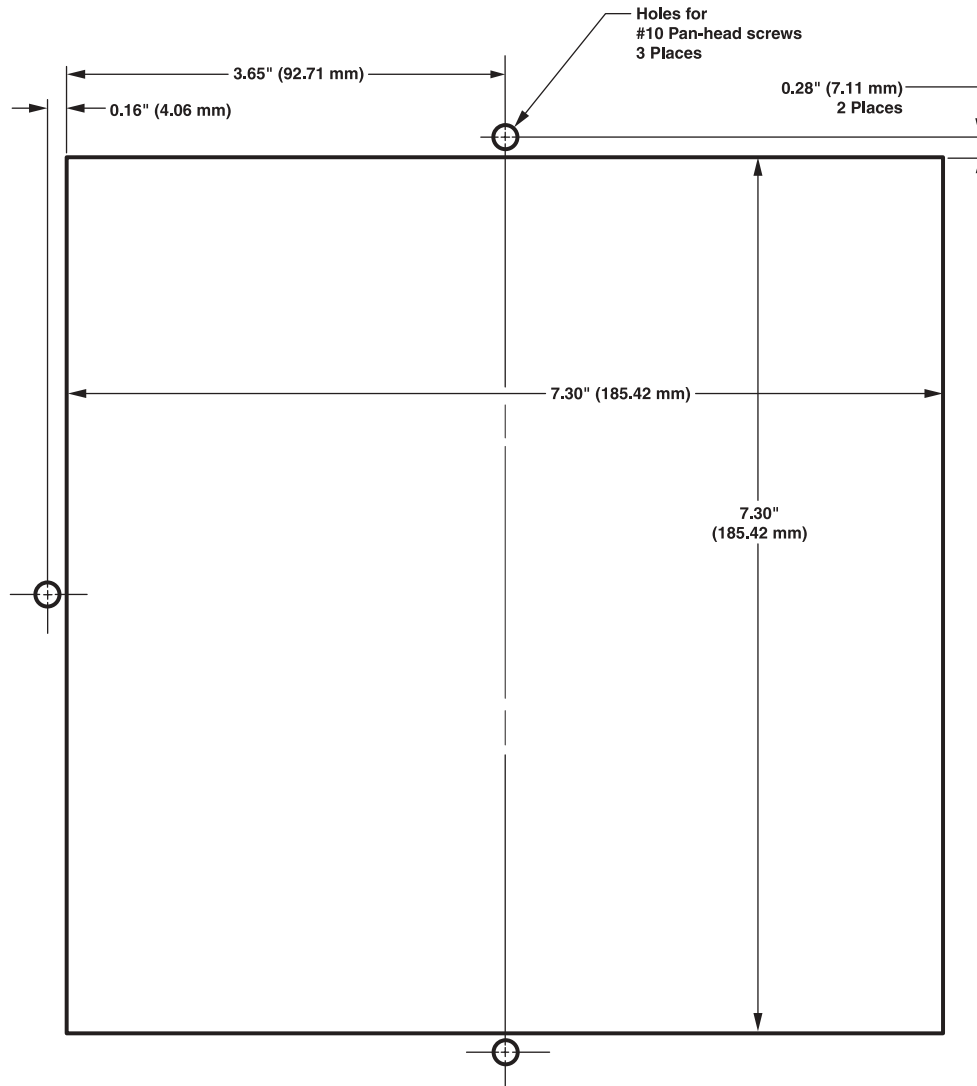



Figure 8 Signal Output Module Opening Dimensions for Panel Mount



### 3.2 SOM Power and Network Connections

#### **DANGER**

*This instrument should be installed by qualified technical personnel to ensure adherence to all applicable electrical codes.*

#### **PELIGRO**

*Este instrumento debe ser instalado por personal técnico capacitado para asegurar el cumplimiento con todos los códigos eléctricos y de plomería aplicables.*

#### **PERIGO**

*Este instrumento deve ser instalado por pessoal técnico qualificado para assegurar o cumprimento de todas as normas elétricas e de canalização aplicáveis.*

#### **DANGER**

*Cet appareil doit être installé par du personnel technique qualifié, afin d'assurer le respect de toutes les normes applicables d'électricité.*

#### **GEFAHR**

*Um zu gewährleisten, daß alle elektrischen VDE-Vorschriften und gegebenenfalls die Zusatzvorschriften der zuständigen Elektrizitäts- und Wasserwerke erfüllt werden, darf dieses Gerät nur von geschultem Fachpersonal installiert werden.*

The SOM is shipped with a Cable Terminator Kit (Cat. No. 52156-00). The cable, at a length specified by the customer, must be ordered separately.

Connect network and power wires to the SOM circuit board, as described below. These network and power connections are then wired either through the sensor's power supply or, if the sensor does not contain an internal power supply, through the Hach PS1201 Power Supply. Refer to the PS1201 Manual or to the appropriate Sensor Manual for wiring connections at their end.

1. Make sure there is no power supplied to the SOM.
2. Use a flat-blade screwdriver to loosen the screws of the SOM front face.
3. Lift the face off the SOM and set it aside. Or, store the front cover by screwing the right side of the face to the left side of the back enclosure.
4. If necessary, carefully use a punch and hammer from the outside of the enclosure to remove one of the left three unused knockouts (shown in [Figure 9](#)) on the bottom of the SOM enclosure. Center the punch on the knockout for best results,
5. Make wire connections as shown in [Table 2](#) and [Figure 10](#).
6. Tighten the strain relief fitting using the supplied washer and locknut until the cable no longer slides in the strain relief.
7. Make other wiring connections at this time if needed.
8. When all necessary connections have been made, ensure that the gasket is properly seated in the SOM face and tighten the screws to 10 in-lb [1.1 n-m] maximum. Do not overtighten the screws.

**Note:** Although conduit is generally not required for the low voltage network wiring, conduit, if used, must be bonded together by the customer. This product does not provide automatic conduit bonding.

**Note:** To assure the devices continue to meet NEMA 4X, I.P.66 enclosure ratings, use only the supplied NEMA-style enclosure strain relief fittings.

---

**Figure 9**      **Knockouts**

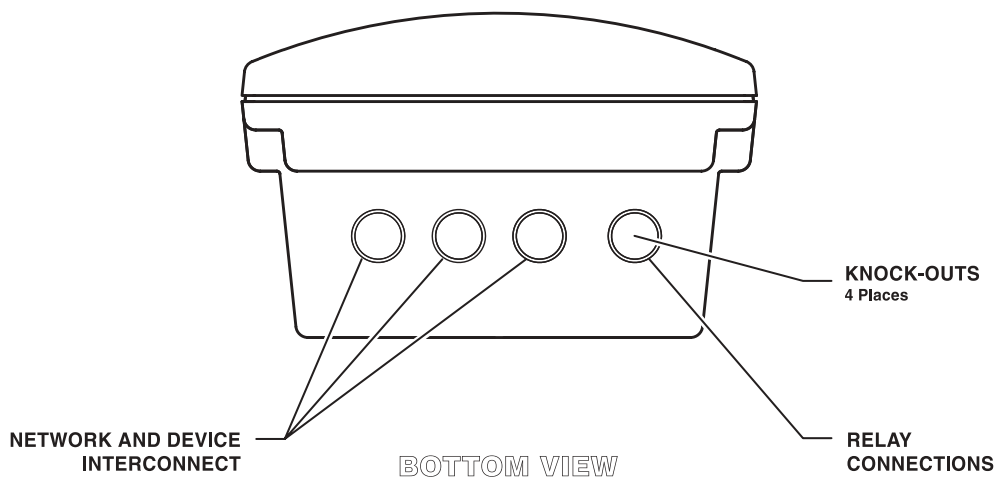

Figure 10 Network Cable Connections

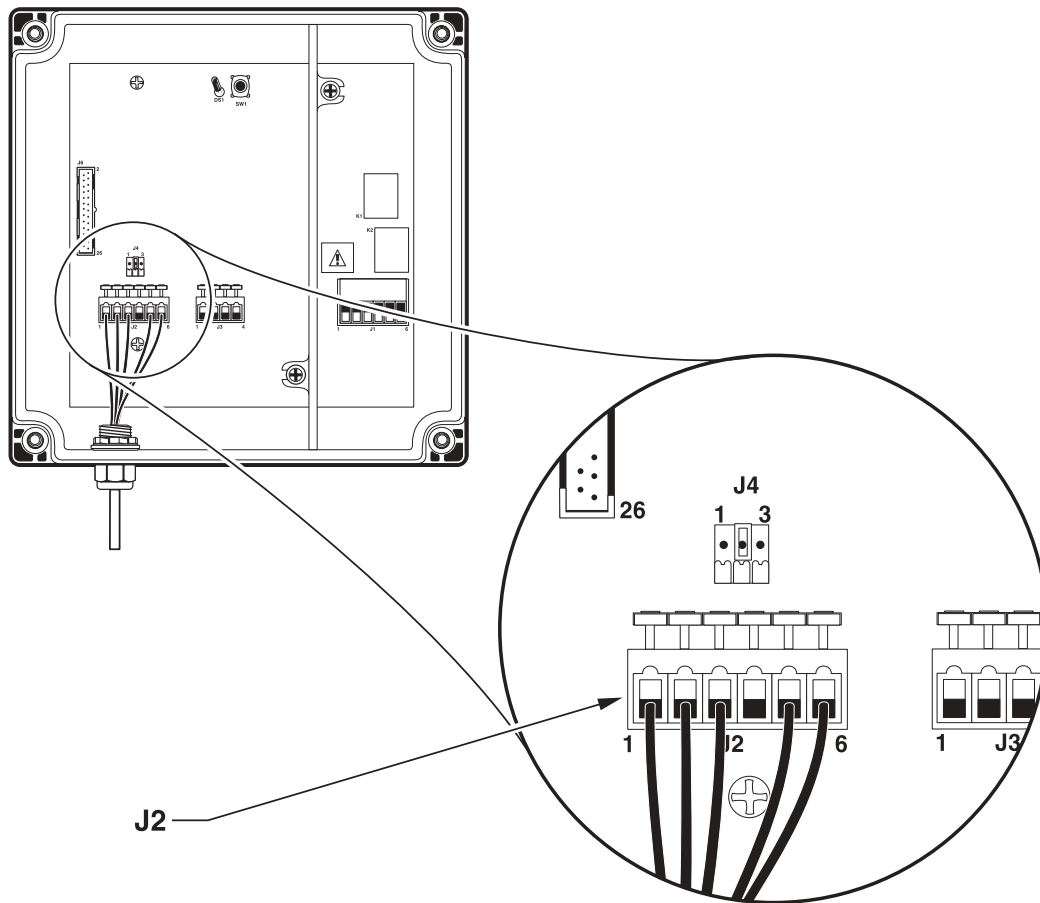

Table 2 J2 Terminal Connections

Terminal Connection	Wire Colors for Hach Cable (Cat. No. 52158)	Function
J2 - 1	Clear	shield, left-most terminal
J2 - 2	Green	network A
J2 - 3	White	network B
J2 - 4	–	no connection
J2 - 5	Red	+12
J2 - 6	Black	ground, right-most terminal

### 3.2.1 Analog Output Connections

Follow the guidelines listed below to connect the analog outputs to the system. Refer to [Figure 11](#) and [Table 3](#) as needed:

- Shielded cable is required for proper operation and compliance.
- Wire gauge must be adequate to handle 20 mA with less than a 5-volt drop over the length of the cable.
- Connect the shield at the receiving device only (e.g., recorder), not at the SOM.
- Refer to [section 3.2.2](#) to connect the current mode outputs to voltage mode inputs.

## Section 3

---



### **DANGER**

*If high-voltage power is applied to the alarm relays, provisions must be made for disconnecting external power to the analyzer during servicing.*

### **PELIGRO**

*En caso de aplicarse una alimentación de alta tensión a los relés de la alarma, deben tomarse las precauciones necesarias para desconectar la potencia externa a los relés del analizador al realizar el servicio.*

### **PERIGO**

*Caso os relés do alarme forem conectados à energia de alta voltagem, deverá ser tomada a precaução de desligar a energia externa dos relés do analisador durante os consertos.*

### **DANGER**

*Si du courant à haute tension doit être appliqué aux relais d'alarmes, il est nécessaire de prévoir un moyen de débrancher l'alimentation électrique externe des relais de l'analyseur au cours de la maintenance.*

### **GEFAHR**

*Soll den Warnrelais Hochspannungsstrom zugeführt werden, ist dafür zu sorgen, daß während der Wartung die externe Stromversorgung zu den Analysator-Relais unterbrochen ist.*

### **CAUTION**

*Nonmetallic enclosure does not provide grounding between conduit connections. Use grounding type bushings and jumper wires.*

### **PRECAUCION**

*Este instrumento deve ser instalado por pessoal técnico qualificado para assegurar cumprimento de todas as normas eléctricas e de canalização aplicáveis.*

### **PRECAUÇÃO**

*Un boîtier non métallique n'assure pas la continuité électrique des conduits. Utiliser des manchons ou des fils de raccord spécialement conçus pour la mise à la terre.*

### **PRUDENCE**

*Un boîtier non métallique n'assure pas la continuité électrique des conduits. Utiliser des manchons ou des fils de raccord spécialement conçus pour la mise à la terre.*

### **VORSICHT**

*Durch das nichtmetallische Gehäuse besteht keine Erdung zwischen den Zuleitungen. Erdungsbuchsen und-drahtbrücken benutzen.*

Four wiring knockouts, sized for ½-inch conduit are located in the bottom of the module (see [Figure 9](#)). Analog output connections are made at the board terminal block J3 on the SOM board (see [Figure 11](#)). The recommended recorder hookup uses shielded, twisted-pair cable. Connect the shield to earth ground (pin 1 of TB1) at the recorder end and leave the SOM end open.

For proper operation, the following conditions are required at the recorder end.

- Input to the recorder must be isolated from earth ground of the recorder.
- If the recorder has more than one input, they must be differential inputs.

Outputs of either 0-20 mA or 4-20 mA can be selected through the sensor menu on the AquaTrend.

**Table 3 SOM Analog Output Connections**

J3 Terminal	Function
J3-1	Analog Out #2 -
J3-2	Analog Out #2 +
J3-3	Analog Out #1 -
J3-4	Analog Out #1 +

### 3.2.2 Using a Voltage Mode Device

To use a current mode output on a voltage mode device (i.e., recorder) refer to [Table 4](#). Follow the instructions in [section 2.5.1 on page 16](#) to adjust the endpoint.

**Table 4 Resistor Values**

Recorder Range	Resistor ( $\pm 5\%$ )
0 - 10 mV	0.5 ohms
0 - 100 mV	5 ohms
0 - 1 V	50 ohms
0 - 10 V	500 ohms

**Figure 11 SOM Analog Output Connections**

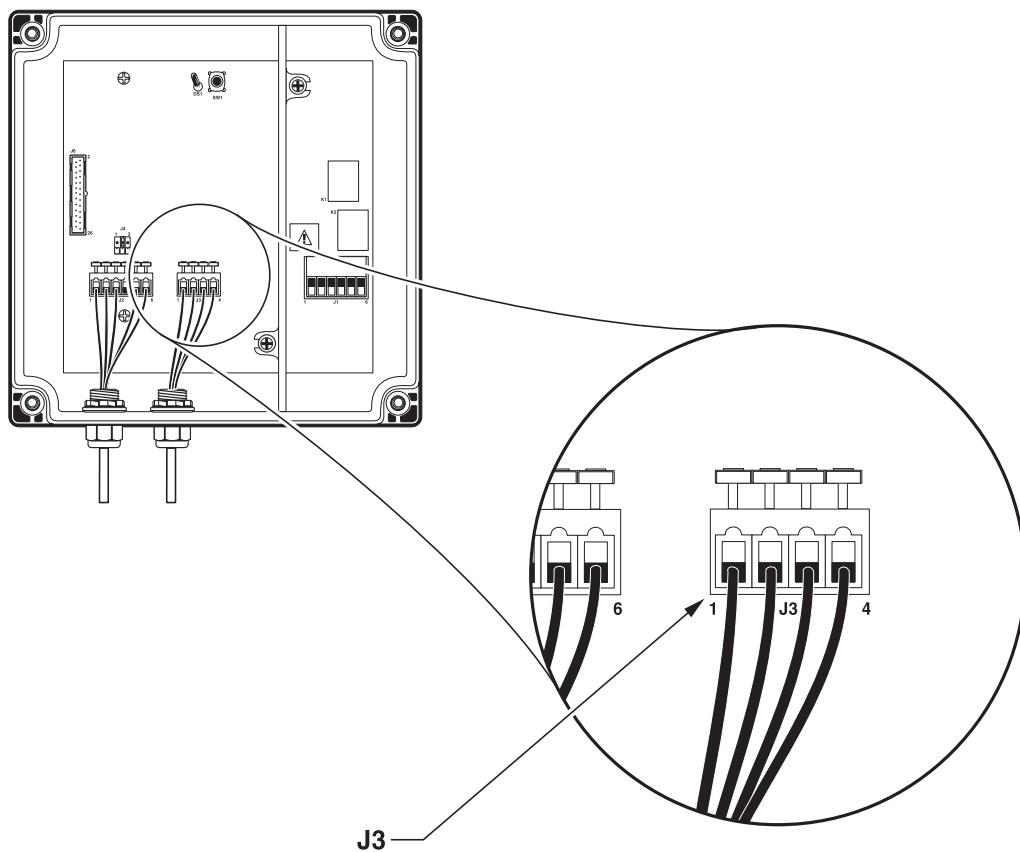

### 3.2.3 Relay Connections

#### **DANGER**

*The relay connection area is designed for either all low voltage (<30 V) or all high voltage (>30 V) connections. A shock hazard exists if low and high voltage connections occur simultaneously in the relay connection area.*

#### **PELIGRO**

*El área de conexión del relé está diseñada para conexiones de bajo (<30 V) o alto (> 30 V) voltaje. Existe un riesgo de descarga eléctrica si ambos tipos de conexión se presentan simultáneamente en el área de conexión del relé.*

#### **PERIGO**

*A área de conexão do relé foi concebida para todas as conexões de baixa voltagem (<30 V) ou de alta voltagem (>30 V). Há risco de choques em caso de ligação simultânea de baixa e de alta voltagem na área de conexão do relé.*

#### **DANGER**

*La zone de connexion des relais est conçue soit pour toutes les connexions en basse tension (<30 V) ou toutes les connexions en haute tension (> 30 V). Un risque d'électrocution existe si des connexions en basse et haute tension sont effectuées simultanément dans la zone de connexions des relais.*

#### **GEFAHR**

*Der Relaisanschlusskasten ist entweder komplett auf Niederspannungs- (<30 V) oder auf Hochspannungsanschluss (>30 V) ausgelegt. Werden sowohl Nieder- als auch Hochspannung im Relaisanschlusskasten angeschossen, besteht die Gefahr eines Stromschlages.*

#### **CAUTION**

*Nonmetallic enclosure does not provide grounding between conduit connections. Use grounding type bushings and jumper wires.*

#### **PRECAUCION**

*La caja protectora no metálica no establece contacto de tierra entre las conexiones de los conductos de cableado. Use manguitos aislantes y cables de cierre especialmente adaptados para la puesta a tierra.*

#### **PRECAUÇÃO**

*Uma caixa não metálica não assegura a ligação à terra entre as condutas. Utilize uniões de tipo ligação à terra e cabos de ligação em ponte.*

#### **PRUDENCE**

*Un boîtier non métallique n'assure pas la continuité électrique des conduits. Utiliser des manchons ou des fils de raccord spécialement conçus pour la mise à la terre.*

#### **VORSICHT**

*Durch das nichtmetallische Gehäuse besteht keine Erdung zwischen den Zuleitungen. Erdungsbuchsen und-drahtbrücken benutzen.*

**Note:** *If voltages >30 V are connected to the relay contacts, you must limit current to the relay contacts to 5 amps and be able to remove power from the relays locally in case of an emergency or for servicing of the product. This can be accomplished with an external switch and a 5-amp fuse or with a switched 5-amp circuit breaker.*

Read the danger and caution statements above, and follow the guidelines listed below to connect the relays to the network. Refer to [Figure 12](#) and [Table 5](#) as needed:

- Shielded cable or metal conduit is required for proper operation and compliance.
- Wire gauge must be adequate to handle intended use.
- Connect the shield at the receiving device only, not at the SOM.
- Do not exceed relay contact rating specifications (5 A, 250 VAC resistive, or 5 A, 30 VDC).

Table 5 Relay Connections

J1 Terminal	Function
1	Relay 1 normally closed
2	Relay 1 normally open
3	Relay 1 common
4	Relay 2 normally closed
5	Relay 2 normally open
6	Relay 2 common

Figure 12 Relay Connections

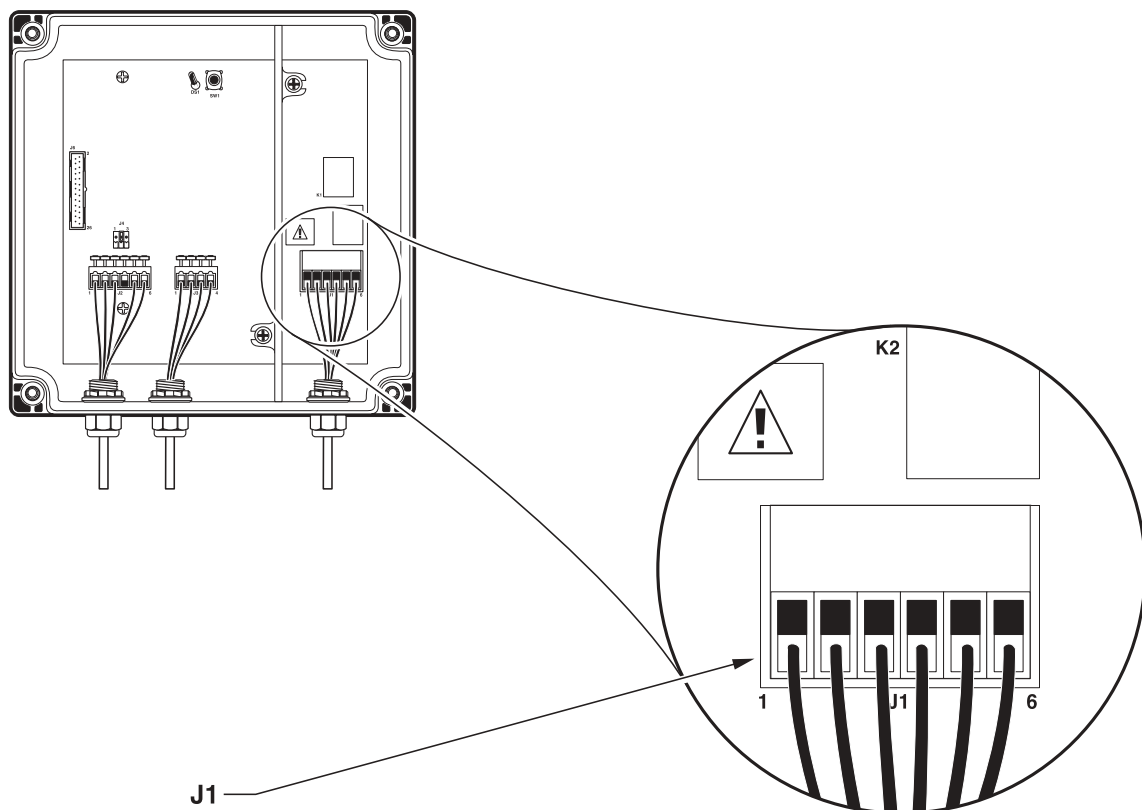

### 3.2.4 Network Terminator Adjustment

The network signals require a terminator for proper operation. As shipped from the factory, the terminator is disabled on all SOMs (See [Figure 13](#)).

**Important Note:** Failure to properly install a terminator the network may cause total network failure. Only one terminator is allowed on the network.

Follow the steps below to enable the terminator and complete the installation of the SOM.

1. Verify if the system Master AquaTrend® Interface is equipped with an SOM by checking the front label and the catalog number on the serial number label:

**AquaTrend Interface** (Cat. No. 51200-60)

## AquaTrend Interface/SOM (Cat. No. 51350-60)

- If the system's Master AquaTrend Interface does not contain an SOM (Model 51200), the terminator should have been enabled on that AquaTrend during installation. Consult the AquaTrend Manual for further instructions.
- If the system's Master AquaTrend Interface contains an SOM (Model 51350), make sure the terminator on that SOM is enabled as follows:
  2. Remove the front face of the AquaTrend Interface/SOM and locate J4 (a white, three-pin connector) on the circuit board in the back enclosure of the device (see Figure 13). A jumper connected only to pin 2 should be present as shown in Figure 14.

Figure 13 J4 Connector

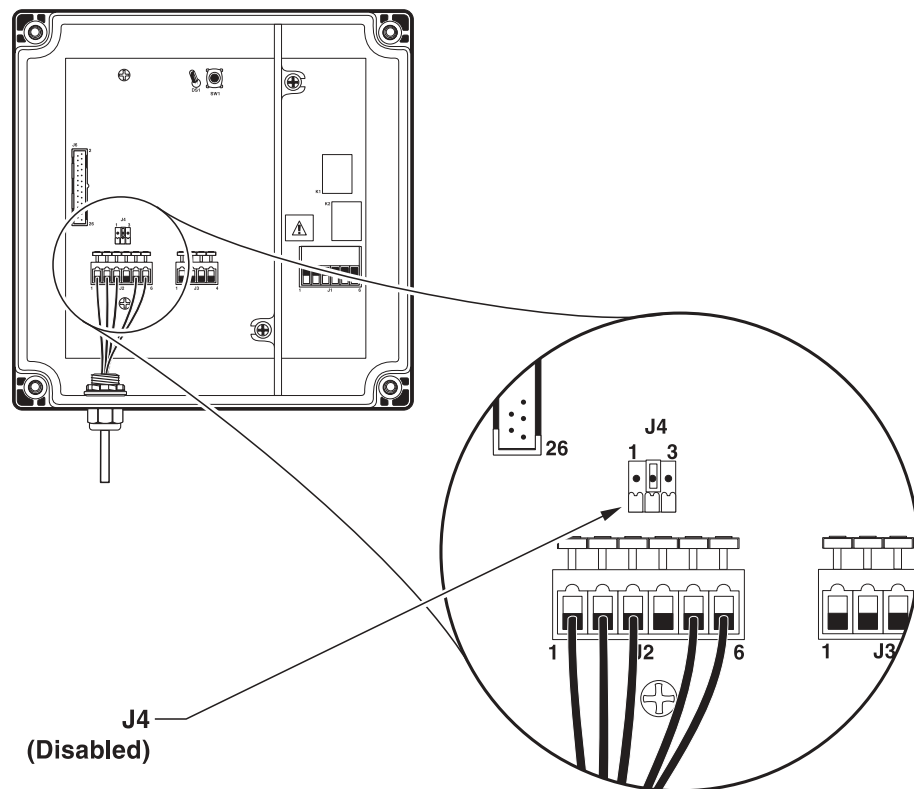
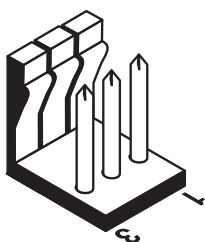

Figure 14 Network Termination

J4 or J6 Connector



Jumper



J4 or J6 Disabled

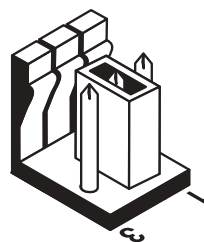

J4 or J6 Enabled

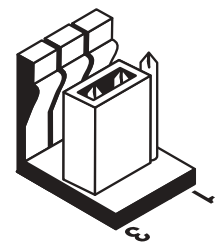



3. To enable the terminator, lift the jumper off of pin 2 and move the jumper so that it connects pins 2 and 3 as shown in [Figure 14](#).
4. Add the SOM to the network using the instructions in [Section 2](#).

### 3.3 Interconnecting a New Device on the Network to an Existing SOM or AquaTrend Interface with SOM

If all of the available access holes and/or wiring terminals in a PS1201 or sensor's power supply have been used, it may be possible to use another existing device (such as an SOM) to provide network and/or power connections for a new device.

Before connecting a new device to an existing device instead of directly to a PS1201, consider the following questions:

1. Is the total power consumed by existing devices, plus the new device, within the capabilities of a single PS1201? (Refer to the PS1201 Manual for information to calculate this.) Failure to confirm this could result in failure of the existing PS1201 due to thermal overload. Such failure is NOT covered by warranty.
2. Is there an unused knockout on the existing device, so that the new connections can be made while preserving network integrity?

**If the answer to BOTH of the above questions is yes:**

The new device can be connected to an existing SOM using its existing PS1201. To connect both power and network signals to the new device via an existing SOM, proceed as follows:

1. Procure the required length of 4-conductor, shielded cable (Cat. No. 52158) to make both the power and network connections.
2. Route the cable in accordance with local building codes. Remove AC input power from the PS1201 that supplies power to all of the devices involved.
3. Strip approximately six inches of insulation from the 4-conductor cable.
4. Insulate the shield using heat-shrink tubing, Cat. No. 40825-00.
5. Remove approximately ½-inch of insulation from each of the remaining wires.
6. Remove, one at a time, each wire from the terminal block of the existing SOM. Match that wire with the same color wire from the new device.
7. Twist the ends of the two wires together and insert them both into the terminal block position where the wire from the existing SOM originated.

Refer to [Figure 10](#) for proper terminal connections.

8. Connect the other end of the new cable to the new device, following the instructions in the manual supplied with that device.

9. After all connections have been verified, reapply input AC power to the PS1201, and follow the instructions in the new device's manual for configuring the new device to function on the network.

**If the answer to question 1 was no, but the answer to question 2 was yes:**

Connect only the cable which sends network signals from the existing SOM to the new device. Connect the new device power connections to an additional PS1201 or sensor power supply. Follow the instructions in the PS1201 or Sensor Manual.

To connect the network signals to the new device from the existing SOM, proceed as follows:

1. Procure the length of 4-conductor, shielded cable (Cat. No. 52158) needed between the new power supply and the new device.
2. Using a Cable Termination Kit (Cat. No. 52156-00), install this cable between the new power supply and the new device according to their respective manuals.
3. Determine the length of cable needed between the new device and the existing SOM. Procure this length of 2-conductor, shielded cable (Cat. No. 52157) plus a Cable Termination Kit (Cat. No. 52156-00).
4. Route the cable in accordance with local building codes, and proceed as follows to connect one end of this cable at the existing SOM:
  - a. Remove input AC power from the power supply that is powering the existing SOM.
  - b. Connect the green and white wires in the new cable to J2-2 and J2-3, respectively, in the existing SOM. Refer to [Figure 10](#) for proper terminal connections.

**Important Note:** *DO NOT connect the shield in the new cable to any terminal in the existing SOM; it must only be connected at the new power supply.*

5. Connect the other end of the cable to the new device as follows:
  - a. Refer to the new device's manual for proper terminal connections.
  - b. Connect the white and green wires to the correct terminals in the new device.
  - c. Insulate the shield using the heat-shrink tubing supplied in the Cable Termination Kit (Cat. No. 52156-00), then connect it to the appropriate terminal in the new device.
6. After all connections have been verified, apply input AC power to both the existing and new power supply, and follow the instructions in the new device's manual for configuring the new device to the network.

## 4.1 Maintenance

No scheduled maintenance is required for the Signal Output Module (SOM). If the module needs cleaning, wipe the external surface with a cloth and warm soapy water as needed. Stronger solvents can damage the labels and housing.

## 4.2 Troubleshooting

The SOM was designed to operate relays and outputs accurately and automatically when setup procedures have been followed properly. The following information describes some minor problems that could arise while setting up or operating the SOM. If these problems persist or other problems develop, please contact the Hach Service Center serving your area (see page 45 for service information).

Problem	Cause	Remedy
Analog outputs not functioning	Not configured	Add or replace the SOM (see <a href="#">Section 2</a> or see the <i>Adding a Device</i> section in the AquaTrend Network Manual).
	Not attached to sensors	Attach outputs to sensor (see the <i>Recorder to Analog Output Connections</i> section in the AquaTrend® Network Manual).
	Cable error	Check cable connections.
Relay outputs not functioning	Not configured	Add or replace the SOM (see <a href="#">Section 2</a> or see the <i>Adding a Device</i> section in the AquaTrend Network Manual).
	Not attached to sensors	Attach outputs to sensor (see the <i>Recorder to Analog Output Connections</i> section in the AquaTrend Network Manual).
	Cable error	Check cable connections.
Network not functioning	Termination not correct	Check all SOMs and AquaTrend Interfaces to make sure that only one network terminator is enabled on the network. See <a href="#">Section 3.2.4</a>

### 4.2.1 Configure LED

The yellow configure LED provides information about the state of the device. The following table describes the state of the device after power up and assumes the **CONFIGURE** button is not being held down.

Configuration LED	Device State	Description/Action
Flashing steady once per second	Unconfigured	Refer to <a href="#">Section 2.1</a> for configuration instructions
Steady Off	Configured	Normal operational state
Steady On	Microprocessor not functioning properly	Call the Hach Service Department
Erratically flashing	Microprocessor not functioning properly	Call the Hach Service Department

The configure LED also lights when the CONFIGURE button is pressed and held.

## 4.3 Unconfiguring the SOM

If the SOM cannot communicate with the AquaTrend Interface, follow the procedure below. After performing this procedure, repeat the SOM network setup in [section 2.1](#).

## Section 4



### DANGER

If high-voltage power is applied to the alarm relays, provisions must be made for disconnecting external power to the analyzer during servicing.

### PELIGRO

En caso de aplicarse una alimentación de alta tensión a los relés de la alarma, deben tomarse las precauciones necesarias para desconectar la potencia externa a los relés del analizador al realizar el servicio.

### PERIGO

Caso os relés do alarme forem conectados à energia de alta voltagem, deverá ser tomada a precaução de desligar a energia externa dos relés do analisador durante os consertos.

### DANGER

Si du courant à haute tension doit être appliqué aux relais d'alarmes, il est nécessaire de prévoir un moyen de débrancher l'alimentation électrique externe des relais de l'analyseur au cours de la maintenance.

### GEFAHR

Soll den Warnrelais Hochspannungsstrom zugeführt werden, ist dafür zu sorgen, daß während der Wartung die externe Stromversorgung zu den Analysator-Relais unterbrochen ist.

**Note:** The SOM contains components that are extremely sensitive to static electricity. When it is necessary to remove the enclosure cover, the proper Electrostatic Discharge (ESD) safeguards **MUST** be taken by the installation or service personnel. Avoid contacting the circuit boards and circuit board components.

**Note:** All previous settings in the SOM are preserved. To verify or change them, refer to [section 2.2](#).

1. Disconnect all AC power to the PS1201 that is powering the SOM and to the relays if high voltage power has been supplied separately to them.
2. Remove the face of the SOM.
3. Press and hold the configure button on the SOM while reconnecting the AC power to the PS1201 (not to the relays). The yellow light next to the button should be continuously lit. Refer to [Figure 15](#).
4. Continue to hold the configure button for at least 5 seconds then release the button. The yellow light next to the button should be flashing.
5. To restore SOM communication to the AquaTrend Interface and Network, either use the Replace Device procedure or follow the Remove Device procedure then the Add Device procedure.

Figure 15 Configure Button

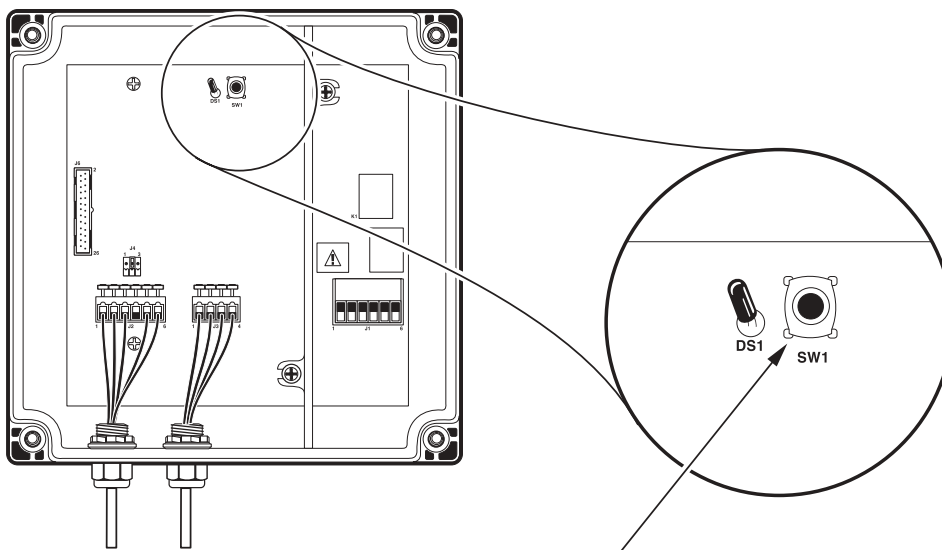

Configure Button

**AquaTrend® Network System** – A system which provides a digital interface link between sensors and communication devices and can receive data from these devices at a maximum distance of up to 1400 m (4593 ft.). The fieldbus communications that makes such configuration possible is provided by Echelon® LonWorks® technology.

The network software may configure up to 35 devices including: one Master AquaTrend Interface, as many as two Serial I/O Modules, and up to eight sensors, eight Signal Output Modules, eight Digital Display Modules, and eight Remote AquaTrends.

**channel** – Where data is displayed and logged on the AquaTrend Interface. The AquaTrend Interface has eight channels (represented by the letters A through H) to which you can attach measurements from sensors.

**configure** – Setting up a Hach network device for operation after hardware installation is complete. This involves selecting various software options and establishing communications between devices.

**device** – Any of the Hach network instruments, including sensors, communications modules, display modules, outputs, and AquaTrends.

**Digital Display Module (DDM)** – An eight-character display that can be used with sensors or analyzers to display a single measurement. It can be mounted as far away as 400 meters (1310 feet) from the sensor.

**Echelon® Technology** – communications technology used by the AquaTrend Network System and developed by Echelon Corporation, producers of LonWorks® fieldbus technology.

**fieldbus** – Any of several techniques allowing multiple devices to be connected on a single set of wires.

**LonWorks** – The fieldbus protocol used by the AquaTrend Network System.

**Master AquaTrend Interface**– Acts as the main network data control center for setup and operation of the network. The network can contain as many as nine AquaTrends but only one can be the Master AquaTrend Interface. Only through the Master AquaTrend Interface can you perform network operations.

**network** – The connection of one or more devices (of which at least one is a sensor or analyzer) to a Master AquaTrend Interface.

**pop-up box** – Refers to a selection or message box at the end of a menu chain. This box either provides a choice of options, selectable by moving the cursor and pressing **ENTER**, or allows you to use the arrow keys to enter an

alphanumeric response, or it states the status of the current operation. These three possibilities, respectively, are shown below.



**Portable AquaTrend** – Mobile device designed to setup and calibrate sensors already setup on the network. Portable AquaTrend Interfaces can access all menus except the network menu and can not perform network operations.

**PS1201** – A power supply that provides 25 watts to the AquaTrend network.

**Remote AquaTrend Interface**– Any AquaTrend Interface on a network that is not a Portable or Master AquaTrend. Remote AquaTrend Interfaces can access all menus except the network menu.

**repeater** – A device capable of amplifying signals when total cable distance is exceeded in order to extend the network's capabilities.

**SCADA** – Supervisory Control and Data Acquisition. General term for any automated (and usually PLC or computer-controlled) system for control and data acquisition.

**sensor** – Any one of the Hach devices designed to take measurements for specific parameters and for use with the AquaTrend Network System (e.g., the 1720D Turbidimeter)

**Serial I/O Module (SIO)** – Communication device for two-way communication with a PC or one-way communication with a printer.

**Signal Output Module (SOM)** – Network device providing two relays, each with normally open and normally closed contacts rated at a maximum of 5A/250 VAC. Also contains two analog outputs, selectable through the AquaTrend keypad at either 4-20 or 0-20 mA. Sensor alarms can be configured to trigger one of the relays in the SOM and/or a recorder or controller signal from a sensor can be attached to one of the analog outputs of the SOM.

The SOM can either be a stand-alone device (model 51250) or can be internal to the AquaTrend Interface/SOM (Model 51350).

**terminator** – Impedance stabilizing component that maintains network signal integrity. One terminator is required for proper network operation, either on an AquaTrend (without SOM) or on a stand-alone SOM.

**topology** – Any wiring configuration, other than bus. See [Figure 16](#) for examples.

Figure 16 Wiring Topologies

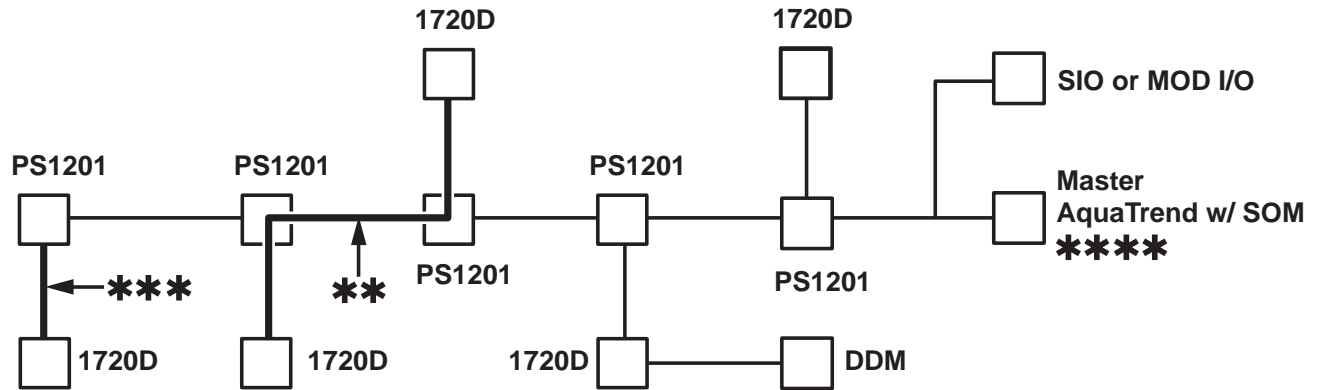

1650 feet (500 meters) Total maximum distance for network communication.

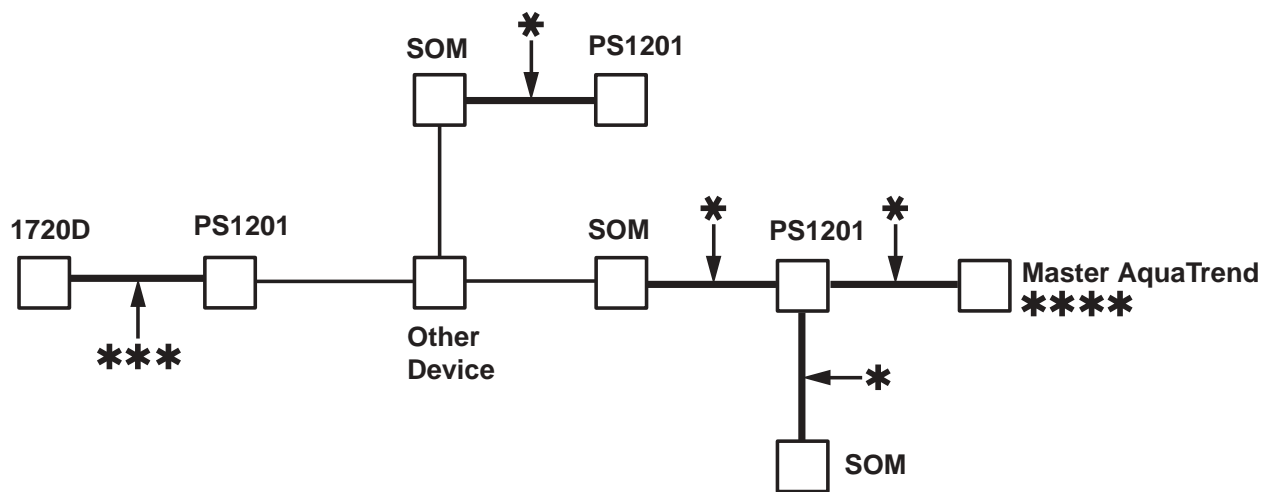

1650 feet (500 meters) Total maximum distance for network communication.

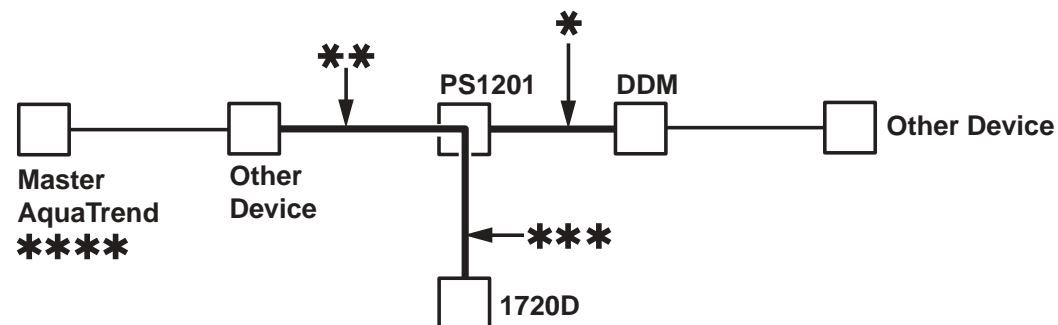

1650 feet (500 meters) Total maximum distance for network communication.  
Distances in excess of 1650 feet (500 meters) require a repeater.

- \* 100 feet (30.3 meters) Maximum distance between the power supply and the device it is powering.
- \*\* 1320 feet (400 meters) Maximum distance between two network devices.
- \*\*\* 20 feet Fixed distance between power supply and 1720D.
- \*\*\*\* Only one enabled terminator is allowed for network.  
(Terminators are located in SOMs, AquaTrends, and SIOs)







## General Information

**At Hach Company, customer service is an important part of every product we make.**

**With that in mind, we have compiled the following information for your convenience.**



## Required Parts and Accessories

Description	Unit	Cat. No.
Cable, 2-conductor, 22-gauge		
by the ft. ....		52157-00
100 ft. ....		52157-10
250 ft. ....		52157-25
500 ft. ....		52157-50
1000 ft. ....		52157-51
Cable, 4-conductor, 20-gauge		
by the ft. ....		52158-00
100 ft. ....		52158-10
250 ft. ....		52158-25
500 ft. ....		52158-50
1000 ft. ....		52158-51
Cable Termination Kit - includes: .....	each	52156-00
Strain Relief Bushing .....	(4)	52025-00
Insulated Quick Connects .....	(6)	52143-00
Heat Shrink Tubing .....	(1 ft.)	40825-00
Locknut, 1/2 inch .....	(4)	10596-12
Washer, Sealing, 1/2 inch NPT .....	(4)	10338-14
Connector, Internal (6) Position Terminal Block (for relay contacts) .....	each	52088-00
Instruction Manual - SOM .....	each	51250-18
PS1201 Power Supply .....	each	52010-00
Relay Output Connector .....	each	52088-00
Signal Output Module (SOM) .....	each	51250-00

## Optional Parts and Accessories

Digital Display Module .....	each	51250-00
Floor Stand .....	each	52160-00
Floor Stand Mounting Hardware (2 U-Bolts) .....	each	51410-00
Repeater Board for AquaTrend® .....	each	52200-00
Signal Input Module .....	each	51450-00
Serial Input/Output Module, 115 V 50/60 Hz with 120 V power supply .....	each	52074-00
Serial Input/Output Module, 230 V 50/60 Hz with 230 V power supply .....	each	52074-02

# How to Order

---

## U.S.A. Customers

**By Telephone:**

6:30 a.m. to 5:00 p.m. MST  
Monday through Friday  
(800) 227-HACH (800-227-4224)

**By Fax:**

(970) 669-2932

**By Mail:**

Hach Company  
P.O. Box 389  
Loveland, Colorado 80539-0389 U.S.A.

**Ordering information by e-mail:** [orders@hach.com](mailto:orders@hach.com)

## Information Required

- Hach account number (if available)
- Your name and phone number
- Purchase order number
- Brief description or model number
- billing address
- Shipping address
- Catalog number
- Quantity

## International Customers

Hach maintains a worldwide network of dealers and distributors. To locate the representative nearest you, send e-mail to [intl@hach.com](mailto:intl@hach.com) or contact:

**Hach Company World Headquarters;** Loveland, Colorado, U.S.A.  
Telephone: (970) 669-3050; Fax: (970) 669-2932

## Technical and Customer Service (U.S.A. only)

Hach Technical and Customer Service Department personnel are eager to answer questions about our products and their use. Specialists in analytical methods, they are happy to put their talents to work for you.

Call 1-800-227-4224 or e-mail [techhelp@hach.com](mailto:techhelp@hach.com)

Authorization must be obtained from Hach Company before sending any items for repair. Please contact the Hach Service Center serving your location.

**In the United States:**

Hach Company  
Ames Service  
100 Dayton Avenue  
Ames, Iowa 50010  
(800) 227-4224 (U.S.A. only)  
FAX: (515) 232-3835

**In Canada:**

Hach Sales & Service Canada Ltd.  
1313 Border Street, Unit 34  
Winnipeg, Manitoba  
R3H 0X4  
(800) 665-7635 (Canada only)  
Telephone: (204) 632-5598  
FAX: (204) 694-5134  
E-mail: [canada@hach.com](mailto:canada@hach.com)

**In Latin America, the Caribbean, the Far East, the**

Indian Subcontinent, Africa, Europe, or the Middle East:  
Hach Company World Headquarters,  
P.O. Box 389  
Loveland, Colorado, 80539-0389 U.S.A.  
Telephone: (970) 669-3050  
FAX: (970) 669-2932  
E-mail: [intl@hach.com](mailto:intl@hach.com)

# Limited Warranty

---

Hach Company warrants this product against any defects that are due to faulty material or workmanship for a period of one year from the date of purchase.

In the event that a defect is discovered during the warranty period, Hach Company agrees that, at its option, it will repair or replace the defective product or refund the purchase price of the defective product less any charges for shipping and handling.

This warranty does not apply to: (i) damage caused by Act of God; (ii) damage caused by misuse, neglect, accident or improper application or installation; (iii) damage caused by any repair or attempted repair not authorized by Hach Company; (iv) any product not used in accordance with the instructions furnished by Hach Company.

Any product repaired or replaced under this warranty will itself be warranted only for the remainder of the warranty period of the original product being repair or replaced.

This warranty does not apply to short-life or consumable components of a product, such as, without limitation, light bulbs and chemical reagents.

## How To Obtain Service

Because Hach Company manufactures and warrants a variety of products, you must receive a Return Authorization and details as to how warranty service may be obtained from Hach Company by calling the appropriate number for your product, see [Repair Service on page 45](#).

## Modifications and Limitations

This warranty contains the sole express warranty made by Hach Company in connection with its products. All implied warranties, including without limitation, the warranties of merchantability and fitness for a particular purpose, are expressly disclaimed.

Some states do not allow the disclaimer of implied warranties and if this is true in your state the above limitation may not apply to you. This warranty gives you specific rights, and you may also have other rights that vary from state to state.

This warranty constitutes the final, complete and exclusive statement of warranty terms and no person is authorized to make any other warranties or representations on behalf of Hach Company.

## Limitation of Remedies

The remedies of repair, replacement or refund of purchase price as stated above are the exclusive remedies for the breach of this warranty. In no event shall Hach Company be liable for any incidental or consequential damages of any kind for breach of warranty, negligence, on the basis of strict Liability or under any other legal theory.

## Geographical Limitation

This warranty is extended only to products purchased, delivered and used in the 50 United States.

Hach Company certifies this instrument was tested thoroughly, inspected and found to meet its published specifications when it was shipped from the factory.

The Signal Output Module (SOM) with and without the AquaTrend® Interface have been tested and are certified as indicated to the following instrumentation standards:

## Product Safety

The SOM was tested with a Hach 1720D and PS 1201 Power Supply in an AquaTrend with SOM configuration.

UL 3101-1 (ETL Listing # H0492805390)

CSA C22.2 No. 1010.1 (ETLc Certification # H0492805390)

Certified by Hach to EN 61010-1 (IEC1010-1) per 73/23/EEC, supporting test records by Intertek Testing Services.

## Immunity

The (SOM) was tested with a Hach PS 2401 and PS 1201 Power Supply in an AquaTrend/SOM configuration.

**EN 61326** (EMC Requirements for Electrical Equipment for Measurement, Control and Laboratory Use) **per 89/336/EEC EMC:** Supporting test records by Hach Company, certified compliance by Hach Company.

### Standards include:

IEC 1000-4-2:1995 (EN 61000-4-2:1995) Electro-Static Discharge Immunity (Criteria B)

IEC 1000-4-3:1995 (EN 61000-4-3:1996) Radiated RF Electro-Magnetic Field Immunity (Criteria A)

IEC 1000-4-4:1995 (EN 61000-4-4:1995) Electrical Fast Transients/Burst (Criteria B)

IEC 1000-4-5:1995 (EN 61000-4-5:1995) Surge (Criteria B)

IEC 1000-4-6:1996 (EN 61000-4-6:1996) Conducted Disturbances Induced by RF Fields (Criteria A)

IEC 1000-4-11:1994 (EN 61000-4-11:1994) Voltage Dip/Short Interruptions (Criteria B)

### Additional immunity Standard/s include:

ENV 50204:1996 Radiated Electro-Magnetic Field from Digital Telephones (Criteria A)

## Emissions

The SOM was tested with a Hach PS2401 and PS 1201 Power Supply in an AquaTrend/SOM configuration.

Per **89/336/EEC EMC: EN 61326:1998** (Electrical Equipment for measurement, control and laboratory use—EMC requirements) Class “A” emission limits. Supporting test records by Hewlett Packard, Fort Collins, Colorado Hardware Test Center (A2LA # 0905-01) and certified compliance by Hach Company.

**Standards include: (applied only to the PS 1201 and 2401 power supplies)**

EN 61000-3-2 Harmonic Disturbances Caused by Electrical Equipment

EN 61000-3-3 Voltage Fluctuation (Flicker) Disturbances Caused by Electrical Equipment

Additional Emissions Standard/s include:

EN 55011 (CISPR 11), Class “A” emission limits

## Canadian Interference-causing Equipment Regulation, IECS-003, Class A

Supporting test records by Hewlett Packard, Fort Collins, Colorado Hardware Test Center (A2LA # 0905-01) and certified compliance by Hach Company.

This Class A digital apparatus meets all requirements of the Canadian Interference- Causing Equipment Regulations.

Cet appareil numérique de la classe A respecte toutes les exigences du Règlement sur le matériel brouilleur du Canada.

## FCC PART 15, Class "A" Limits

Supporting test records by Hewlett Packard, Fort Collins, Colorado Hardware Test Center (A2LA # 0905-01) and certified compliance by Hach Company.

This device complies with Part 15 of the FCC Rules. Operation is subject to the following two conditions:

(1) this device may not cause harmful interference, and (2) this device must accept any interference received, including interference that may cause undesired operation.

Changes or modifications to this unit not expressly approved by the party responsible for compliance could void the user's authority to operate the equipment.

This equipment has been tested and found to comply with the limits for a Class A digital device, pursuant to Part 15 of the FCC Rules. These limits are designed to provide reasonable protection against harmful interference when the equipment is operated in a commercial environment. This equipment generates, uses, and can radiate radio frequency energy and, if not installed and used in accordance with the instruction manual, may cause harmful interference to radio communications. Operation of this equipment in a residential area is likely to cause harmful interference, in which case the user will be required to correct the interference at his own expense. The following techniques of reducing the interference problems are easily applied.



1. Disconnect the Signal Output Module from its power source to verify that it is or is not the source of the interference.
2. If the AC power supply or the power to relay contacts for the Signal Output Module are connected into the same outlet as the device with which it is interfering, try another outlet.
3. Move the Signal Output Module away from the device receiving the interference.
4. Reposition the receiving antenna for the device receiving the interference.
5. Try combinations of the above.



## A

adding an SOM .....	9
alarm .....	28, 36
alarm to relay .....	12
analog output .....	14, 28
settings .....	15
trim .....	16
analog outputs .....	4, 27, 35

## C

cable	
shielded .....	27
Cable Terminator Kit .....	26
cleaning .....	35
communication	
SIO with AquaTrend .....	35
Configuration LED .....	35
configuring DDM by AquaTrend .....	7
connections	
analog output .....	28, 29
analog outputs .....	27
cable .....	27
network .....	25
recorder to analog output .....	14
relay .....	30
terminal .....	27

## E

Echelon LonWorks .....	37
------------------------	----

## F

fieldbus communications .....	37
-------------------------------	----

## G

General Installation Information .....	7
--	---

## I

installation .....	21
basics .....	7
mounting .....	21

## J

jumper position .....	32
-----------------------	----

## L

labels .....	3
LonWorks .....	37

## M

maintenance	
cleaning .....	35
Master AquaTrend .....	31
menus	
network menu .....	7
other device menu .....	7
sensor menu .....	7
mounting .....	21
bracket .....	21, 22
panel .....	24
pole .....	21
screws .....	22
template .....	22
wall .....	22

## N

naming the SOM .....	9
characters .....	11
edit name .....	11
network .....	35
connections .....	25
setup .....	9
wiring .....	26
network setup	
adding an SOM .....	9
alarm to relay .....	12
naming the SOM .....	9
network terminator adjustment .....	31

## O

ON COMM LOSS .....	16
output trim .....	16

## P

power .....	4
wiring .....	26
power supply .....	26
sensor .....	26
PS1201 .....	26

# Index

---

## R

recorder .....	14
hookup .....	28
range .....	29
relay settings .....	12
communication loss .....	12
relays .....	4, 12, 28, 35, 36
test .....	13
resistor values .....	29

## S

safety	
labels .....	3
shield .....	28
shielded cable .....	27
Signal Output Module (SOM) .....	14
signals	
network .....	31

solvents .....	35
strain relief .....	26

## T

terminal block .....	28
terminator adjustment .....	31
test relays .....	13
troubleshooting .....	35

## U

U-bolt .....	21
--------------	----

## V

voltage mode device .....	29
---------------------------	----

## W

wire gauge .....	27
------------------	----