



DOC023.53.90171

TSS EX1 sc

User Manual

07/2017, Edition 8

Turbidity and Solid matter sensor TSS EX1 sc

Table of contents

Section 1 Specifications	5
1.1 Dimensions	6
Section 2 General information	7
2.1 Safety information	7
2.1.1 Hazard warnings in this manual	7
2.1.2 Warning labels	8
2.2 Areas of application	8
2.3 Measuring principle	9
2.3.1 Turbidity according to DIN standards	9
2.3.2 Measurement of solids according to plant-specific curves	9
2.4 Handling	9
2.5 Scope of delivery	9
Section 3 Installation	11
3.1 Installation overview of basin sensor	12
3.2 Installation sensor pipe installation option	13
3.3 Grounding	13
3.4 Installation of the sc controller	13
3.5 Connect the sensor cable	13
3.5.1 Attaching a sc Sensor with a Quick-connect Fitting in a Hazardous Location	14
Section 4 Operation	17
4.1 sc controller operation	17
4.2 Sensor setup	17
4.3 Sensor data logger	17
4.4 Menu structure	17
4.4.1 SENSOR STATUS	17
4.4.2 SENSOR setup	18
4.5 CALIBRATE	20
4.5.1 Calibration of the TURBIDITY (TRB) parameter	20
4.5.1.1 Select TURBIDITY (TRB) parameter	20
4.5.1.2 FACTOR	20
4.5.1.3 OFFSET	21
4.5.1.4 1 to 3 point calibration	21
4.5.2 Calibration of the SOLID (TS) parameter	22
4.5.2.1 Select the SOLID (TS) parameter	22
4.5.2.2 FACTOR	22
4.5.2.3 1 to 3 point calibration	23
4.5.3 General information about calibration	24
4.5.3.1 Delete recorded points	24
4.5.3.2 Delete a calibration point	24
Section 5 Maintenance	25
5.1 Maintenance schedule	25
5.2 Clean the measurement windows	25

Table of contents

Section 6 Malfunctions, causes, resolution	27
6.1 Error messages.....	27
6.2 Warning messages.....	27
Section 7 Replacement parts and accessories	29
7.1 Replacement parts	29
7.2 Accessories	29
Section 8 Limited warranty	31
Appendix A Modbus register	33
Index	35

Section 1 Specifications

Specifications are subject to change without notice.

Measurement		
Measurement method	Combined multiple-beam alternating light technique with IR diode system and beam focusing	
	Turbidity (TRB)	2-channel 90° scattered light measurement in accordance with DIN/EN 27027/ISO7027, wavelength = 860 nm additional measurement value verification through eight-channel multiple-angle measurement
	Solid matter (TS)	Modified absorption measurement: Eight-channel multiple-angle measurement, wavelength = 860 nm
	Air-bubble compensation	Software-based
	Measurement value compensation	Software-based (process-adaptable)
Measurement range	Turbidity (TRB)	0.001 to 9999 FNU
	Solid matter (TS)	0.001 to 500 g/L
Measurement accuracy	Turbidity (TRB)	Up to 1000 FNU/NTU: < 5% of measurement value ± 0.01 FNU/NTU
Reproducibility	Turbidity (TRB)	< 3%
	Solid matter (TS)	< 4%
Response time	1 s ≤ T90 ≤ 300 s (adjustable)	
Calibration	Turbidity (TRB)	Calibrated before shipping
	Solid matter (TS)	To be calibrated on site by the customer
	Zero point	Calibrated permanently before shipping
Environmental conditions		
Pressure range	≤ 10 bar or ≤ 100 m (≤ 145 PSI)	
Flow rate	Maximum 3 m/s (air bubbles created affect measurement)	
Ambient temperature	-10 to 50 °C (14 to 122 °F)	
Distance: Sensor — Wall/Floor	Solid matter (TS) > 10 cm, turbidity (TRB) > 50 cm	
Instrument properties		
Dimensions	Basin sensor:	Ø x L 48.5 mm x 385 mm (1.91 in x 15.16 in)
	Installation sensor (TriClamp):	Ø x L 48.5 mm x 448 mm (1.91 in x 17.64 in)
	Installation sensor (InLine):	Ø x L 48.5 mm x 410 mm (1.91 in x 16.03 in)
Materials	Parts in contact with medium	Head: stainless steel DIN 1.4460
		Sleeve: stainless steel DIN 1.4404
	Sensor connection cable (permanently connected), Semoflex (PUR):	Shank: stainless steel DIN 1.4571 Sapphire glass Gaskets: FPM
Cable hardware	1 AWG 22/12 V DC twisted cable pair, 1 AWG 22/data twisted cable pair, shared cable screen	
Weight	Basin sensor, installation sensor (TriClamp/InLine): approximately 2.7 kg	

Specifications

Cable length	10 m (32.81 ft), maximum 100 m (328 ft) with extension cable
Miscellaneous	
Inspection interval	upon request 1/year service contract with warranty extension to 5 years
Maintenance requirements	1 hour/month, typical
Declarations of conformity	CE, GS from the Technical Inspection Association, UL/CSA, FM
Grounding	Ground wire 4 mm ² minimum
Hazardous location certifications	Class I Division 2 Groups A, B, C, D, T4 Class I Zone 2 Group IIC, T4

1.1 Dimensions

Figure 1 Dimensions

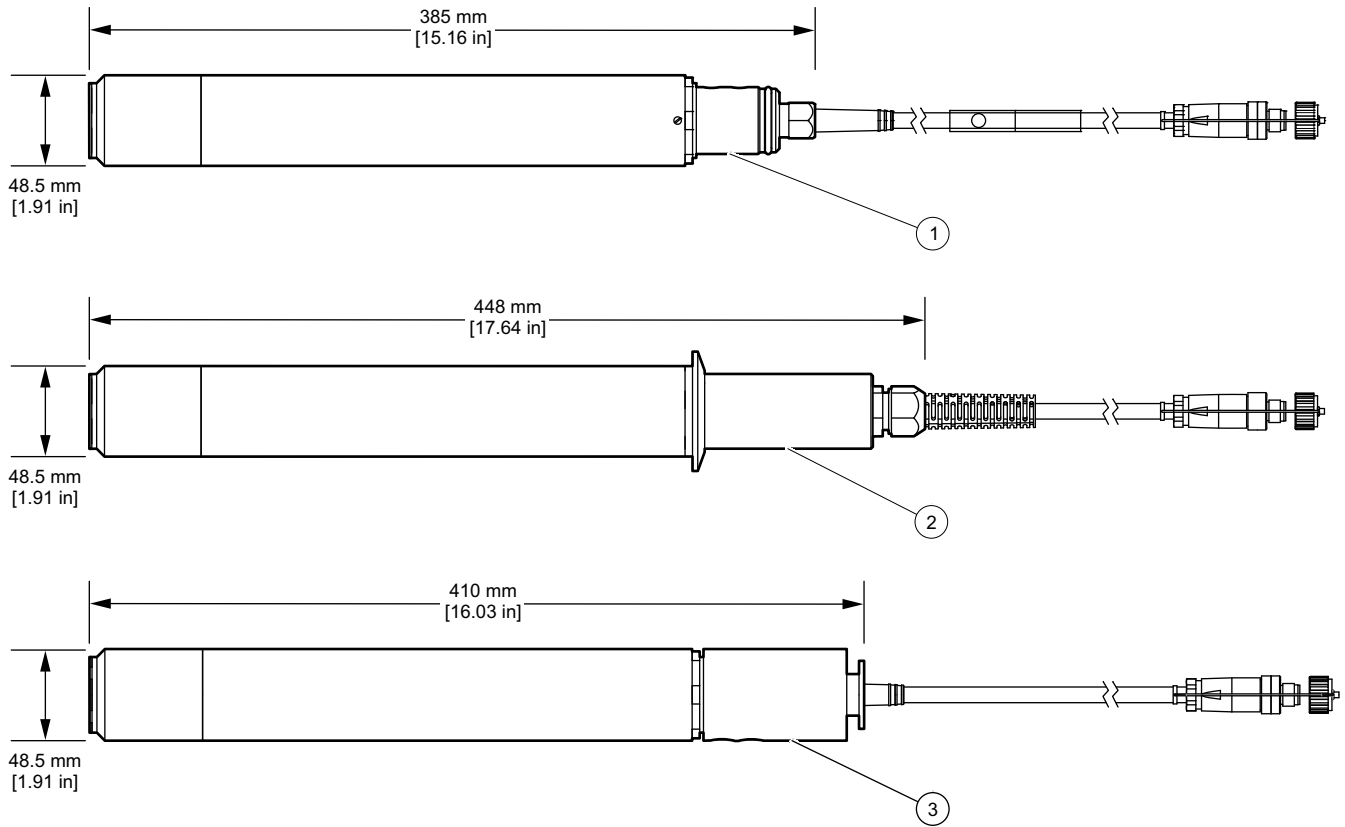

1 Basin sensor	2 Installation sensor (TriClamp)	3 Installation sensor (InLine)
-----------------------	---	---------------------------------------

Section 2 General information

2.1 Safety information

Please read this entire manual before unpacking, setting up, or operating this equipment. Pay attention to all danger and caution statements. Failure to do so could result in serious injury to the operator or damage to the equipment.

To ensure that the protection provided by the equipment is not impaired, do not use or install this equipment in any manner other than that specified in this manual.

DANGER

Class I Division 2
Groups A, B, C, D, T4
Class I Zone 2
Group IIC, T4.

DANGER

The probe (especially the type plate) must not be cleaned with or come into contact with acetone or p-Xylene, or any liquids containing these solvents.

DANGER

The free end of the feed hose must be connected either outside of the zone at risk of explosion or within equipment approved for the equipment category in question.

2.1.1 Hazard warnings in this manual

DANGER

Indicates a potentially or imminently hazardous situation that, if not avoided, can result in death or serious injury.

WARNING

Indicates a potentially or imminently dangerous situation that, if it is not avoided, can lead to death or to serious injuries.

CAUTION

Indicates a potentially hazardous situation that may result in minor or moderate injury if it is not avoided.

NOTICE



Indicates a situation that, if it is not avoided, can lead to damage to the device. Information that requires special emphasis.

Note: Information that supplements points in the main text.

General information

2.1.2 Warning labels

Read all labels and tags attached to the instrument. Failure to do so may result in personal injury or damage to the instrument.

	This symbol may have been attached to the device, and in such cases it references the instruction manual for operating and/or safety information.
	This symbol may have been attached to a housing or barrier in the product and warns that there is a risk of electric shock and/or danger of death by electrocution.
	Electrical equipment marked with this symbol may not be disposed of in European domestic or public disposal systems after August 12, 2005. In conformity with European local and national regulations (EU Directive 2002/96/EC), European electrical equipment users must now return old or end-of life equipment to the manufacturer for disposal at no charge to the user. Note: Instructions on the correct disposal of all (marked and unmarked) electrical products supplied or manufactured by Hach-Lange may be obtained from your local Hach-Lange sales office.

2.2 Areas of application

Figure 2 Overview

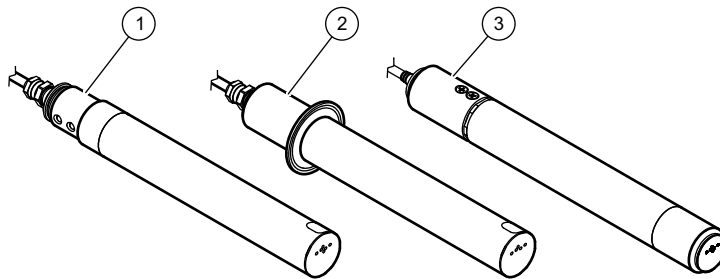

1 Basin sensor	2 Installation sensor (TriClamp)	3 Installation sensor (InLine)
----------------	----------------------------------	--------------------------------

The TSS EX1 sc sensor is an extremely accurate turbidity and solid sensor made from stainless steel for color-independent measurement of highly concentrated sludges.

This sensor was specially developed for
Class I Division 2
Groups A, B, C, D, T4
Class I Zone 2
Group IIC, T4

2.3 Measuring principle

2.3.1 Turbidity according to DIN standards

Turbidity is measured in accordance with DIN standard EN 27027 (ISO 7027) and is calibrated by the manufacturer. Measurement is exceptionally simple and accurate.

2.3.2 Measurement of solids according to plant-specific curves

Software-based optimization routines enable extremely precise simulation of medium-specific calibration curves with few calibration points. Usually, a single calibration point is sufficient.

Up to three calibration points can be defined for a strongly fluctuating medium. The combined multiple-beam alternating light technique records solids in the medium with even greater accuracy.

2.4 Handling

DANGER

Switch off the sc controller before connection or disconnection of the probe and sc controller.

NOTICE

Protect the probe from impacts and never rest the probe on the measurement head.

NOTICE

Never operate the probe within powerful magnetic fields! (EN50021 6.4)

2.5 Scope of delivery

- TSS EX1 sc sensor
- Test log
- Operating instructions

Make sure that all components have been received. If any items are missing or damaged, contact the manufacturer or a sales representative immediately.

Section 3 Installation

DANGER

Observe the requirements for installation in hazardous zones.
This system must only be installed by qualified experts in accordance with all local safety regulations.

DANGER

DANGER
EXPLOSION HAZARD - DO NOT DISCONNECT EQUIPMENT UNLESS POWER HAS BEEN SWITCHED OFF OR THE AREA IS KNOWN TO BE NON-HAZARDOUS.

AVERTISSEMENT - RISQUE D'EXPLOSION - AVANT DE DECONNECTER L'EQUIPEMENT, COUPER LE COURANT OU S'ASSURER QUE L'EMPLACEMENT EST DESIGNÉ NON DANGEREUX.

***Note:** Depending on the area of application, the sensor may have to be installed with additional optional accessories*

3.1 Installation overview of basin sensor

Figure 3 Example of installation with optional accessories

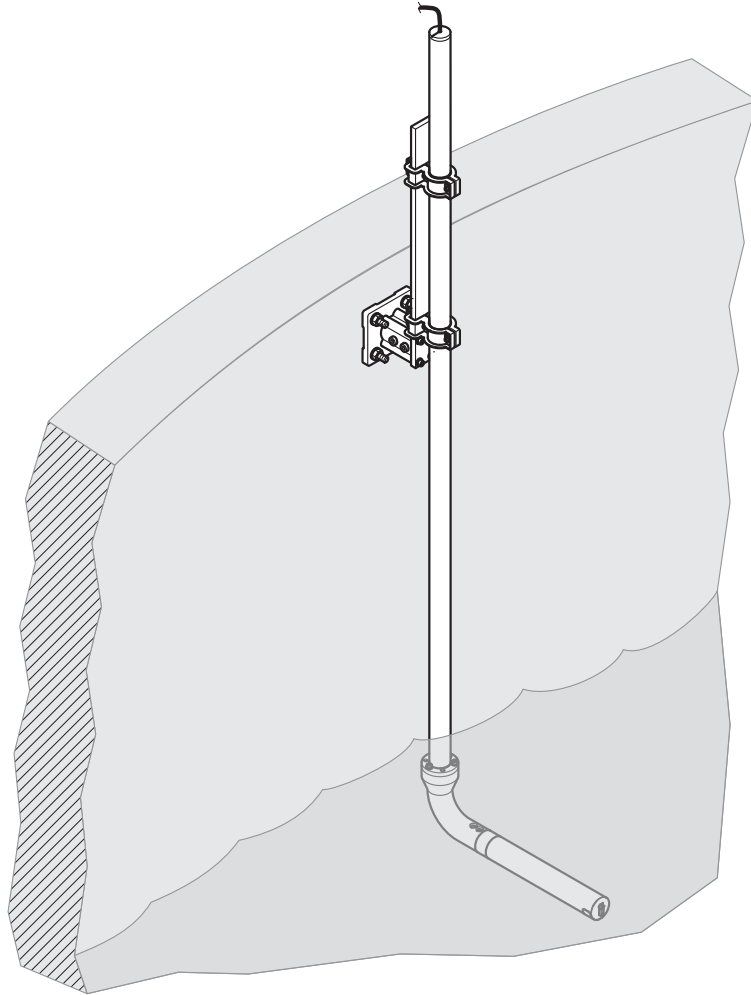

3.2 Installation sensor pipe installation option

Figure 4 Installation options

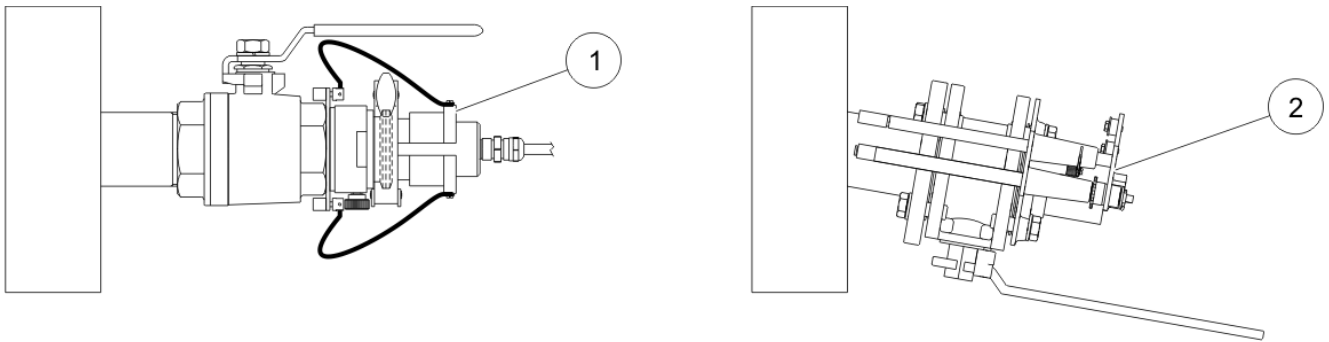

<p>1 TSS EX1 sc TriClamp with retractable ball valve fitting (maximum operating pressure 1.5 bar; LZU301.99.00000)</p>	<p>2 TSS EX1 sc Inline with built in safety valve LZY630.00.2x000 (maximum operating pressure 6 bar) (x= Identifier for material selection of the corresponding connecting flange))</p>
---	--

3.3 Grounding

DANGER

Make sure that a ground wire with a cross-section of at least 4 mm² at the cable lug is attached directly to the probe/the band clamp on the assembly rod. The ground wire must be attached with a screw and lock washer.

3.4 Installation of the sc controller

Note: The sc200 controller can be installed within the hazardous zone.

3.5 Connect the sensor cable

CAUTION

Always lay cables and hoses so that they do not pose a tripping risk.

1. Unscrew the protective caps from the sc controller socket and the cable plug and retain them.
2. Pay attention to the guide in the plug and slide the plug into the socket.
3. Tighten the nut by hand.

Note: Extension cables are available in various lengths (refer to [Section 7 Replacement parts and accessories](#)). Maximum cable length 100 m (328 ft).

Figure 5 Connect the sensor plug to the sc controller

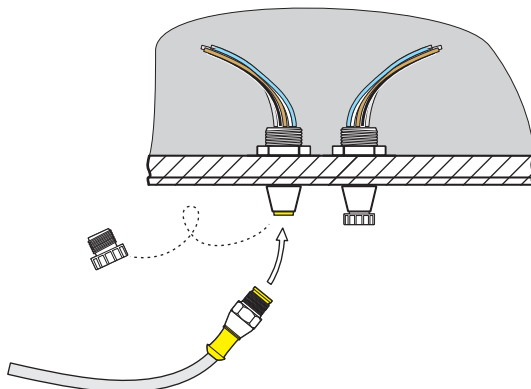
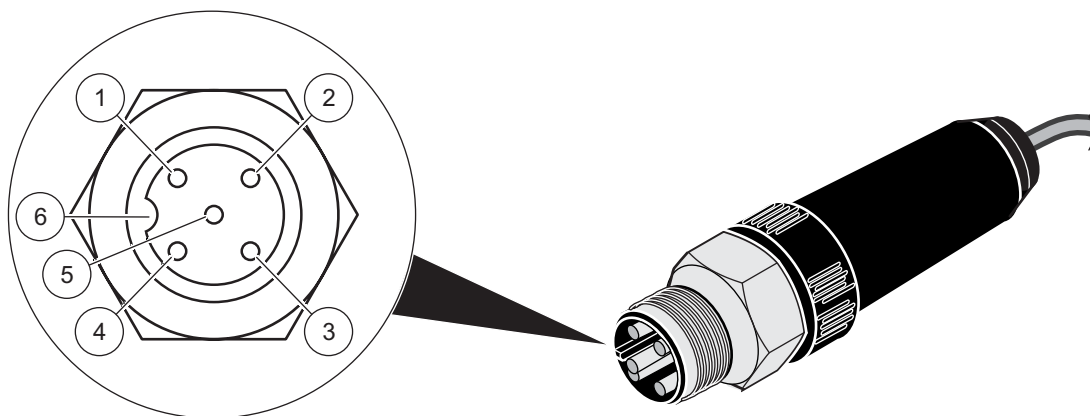

Figure 6 Pin assignment



Number	Description	Cable color
1	+12 VDC	Brown
2	Earth	White
3	Data (+)	Blue
4	Data (-)	Black
5	Screen	Screen (gray)
6	Guide	

3.5.1 Attaching a sc Sensor with a Quick-connect Fitting in a Hazardous Location

The sensor cable is supplied with a keyed quick-connect fitting for easy attachment to the controller, see [Figure 5](#). For hazardous locations, a connector safety lock is supplied and **must** be installed (see [Figure 7 on page 15](#)). Retain the connector cap to seal the connector opening in case the sensor must be removed.

Note: The load termination box (Cat. No. 5867000) cannot be used in a hazardous location.

1. Remove the connector cap from sc200 controller. Retain the connector cap to seal the connector opening in case the sensor must be removed.
2. Connect the sensor connector to the plug on the sc200.

3. Install a connector safety lock (Figure 7). Align the lock over the connector and squeeze the two halves together to lock. To remove the connector safety lock by inserting a small flat-bladed screwdriver into the locking groove. Pivot the screwdriver away from the groove and separate the two halves (Figure 7).

Figure 7 Installing the Connector Safety Lock

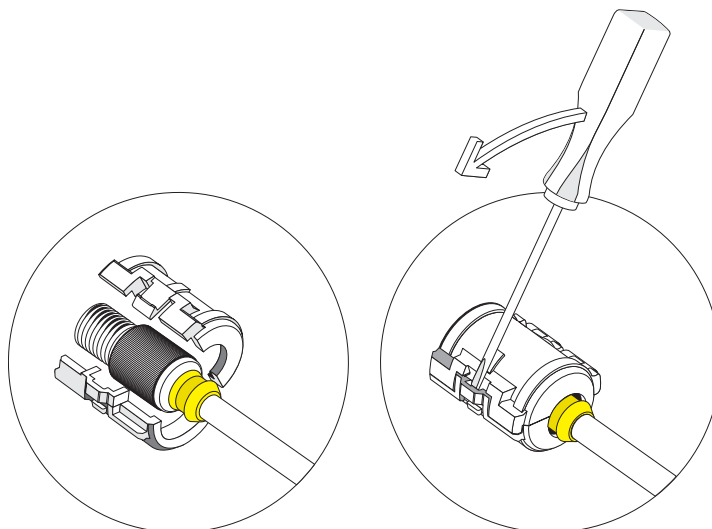

Section 4 Operation

4.1 sc controller operation

The sensor can be operated with all sc controllers. Become familiar with the functionality of the sc controller before using the sensor. Learn how to navigate the menu and execute the corresponding functions.

4.2 Sensor setup

When the sensor is connected for the first time, the sensor serial number is displayed as the sensor name. The sensor name can be changed as follows.

1. Open the MAIN MENU.
2. Press SENSOR SETUP and confirm.
3. Select the corresponding sensor and confirm.
4. Select CONFIGURE and confirm.
5. Press EDITED NAME and confirm.
6. Edit the names and confirm to return to the CONFIGURE menu.

Complete the system configuration in the same way by defining settings for the following menu items:

- MEAS UNITS
 - PARAMETERS
 - RESPONSE TIME
 - LOGGER INTERVAL
7. Go back to the MAIN MENU or the Measurement mode display.

4.3 Sensor data logger

A data storage unit and an event memory unit are provided for each sensor. The data storage unit stores measurement data at predefined time intervals, while the event memory unit stores events such as configuration changes, alarms and warning conditions. Both storage units can be output in CSV format (refer to sc controller manual).

4.4 Menu structure

4.4.1 SENSOR STATUS

SELECT SENSOR (if there is more than one sensor)	
ERRORS	Possible error messages: MEAS. OVERRANGE, CAL. INSUFF. +/-, ZERO, CAL REQUIRED, EE RSRVD ERR, ERROR PROBE, LED FAILURE
WARNINGS	Possible warning messages: TEST/MAINT

Note: Refer to [Section 6 Malfunctions, causes, resolution](#) for a list of all error and warning messages as well as a description of all necessary corrective actions.

Operation

4.4.2 SENSOR setup

SELECT SENSOR (if there is more than one sensor)	
WIPE	Triggers a wiping operation
CALIBRATE (turbidity)	
OUTPUT MODE	Behavior of the outputs during calibration or while the zero point is being set
HOLD	
ACTIVE	
TRANSFER	
SELECTION	
SENS MEASURE	Current, uncorrected measurement value
FACTOR	Can be set from 0.10 to 10.00, a detailed description is provided in section 4.5 CALIBRATE
OFFSET	Can be set from -100 to +100, a detailed description is provided in section 4.5 CALIBRATE
CALIBRATE	
MEMORY	
POINT 1	Calibration point 1 is recorded
POINT 2	Calibration point 2 is recorded
POINT 3	Calibration point 3 is recorded
CLEAR MEMORY	Clears the recorded values for all points.
POINT 1	Current calibration for point 1
POINT 2	Current calibration for point 2
POINT 3	Current calibration for point 3
SET CAL DEFLT	Security prompt, reset to default calibration
CALIBRATE (TS content)	
OUTPUT MODE	Behavior of the outputs during calibration or while the zero point is being set
HOLD	
ACTIVE	
TRANSFER	
SELECTION	
SENS MEASURE	Current, uncorrected measurement value
FACTOR	Can be set from 0.10 to 10.00, a detailed description is provided in section 4.5 CALIBRATE
CALIBRATE	
MEMORY	
POINT 1	Calibration point 1 is recorded
POINT 2	Calibration point 2 is recorded
POINT 3	Calibration point 3 is recorded
CLEAR MEMORY	Clears the recorded values for all points.
POINT 1	Current calibration for point 1
POINT 2	Current calibration for point 2
POINT 3	Current calibration for point 3
SET CAL DEFLT	Security prompt, all calibration points are cleared

4.4.2 SENSOR setup

SELECT SENSOR (if there is more than one sensor)	
CONFIGURE	
EDIT NAME	Name can include up to 16 characters, FACTORY CONFIG: Device number
MEAS UNITS	TRB: (FNU, EBC, TE/F, NTU, FTU) TS: (mg/L, g/L, ppm, %) FACTORY CONFIG: FNU
PARAMETERS	TRB, TS, FACTORY CONFIG: TRB
RESPONSE TIME	1 to 300 s, FACTORY CONFIG: 60 s
LOGGER INTERVAL	10 s, 30 s, 1 min, 2 min, 3 min, 4 min, 5 min, 6 min, 10 min, 15 min, 30 min, FACTORY CONFIG: 10 min
FACTORY CONFIG	Security prompt, reset to factory configuration for all menu items listed above.
TEST / MAINT	
PROBE INFO	
SENSOR NAME	Device name
EDITED NAME	
INSTRUMENT NUMBER	
TURBIDITY	0.001 to 9999 FNU
SOLID	0.001 to 500 g/L
MODEL NUMBER	Sensor item number
CODE VERSION	Sensor software
COUNTER	MANUAL RESET PRESS ENTER: Security prompt TEST / MAINT: COUNTER X DAYS BACKWARDS, TOTAL: OPERATING HOURS COUNTER,
INTERVAL	Default for maintenance counter
SERVICE	
SIGNALS	Explanation: refer to service manual
S5E1	
S5E3	
S6E1	
S6E3	
S5E2	
S5E4	
S6E2	
S6E4	
OUTPUT MODE	Behavior of instrument outputs in the SERVICE menu
HOLD	
ACTIVE	
TRANSFER	
SELECTION	
	Service access

4.5 CALIBRATE

Note: Turbidity measurement has been calibrated by the manufacturer — it does not need to be calibrated again.

Note: It is imperative to calibrate for solid matter measurement (refer to section 4.5.2 Calibration of the SOLID (TS) parameter).

The zero point for turbidity and solid matter measurement has been set in the sensors by the manufacturer.

Installation conditions in the pipes can cause interfering ground reflection when measuring turbidity, which in turn may cause the zero point to shift. Compensate for this effect with an offset correction (section 4.5.1.3 OFFSET). If there are deviations between the displayed measurement values and laboratory results that are unrelated to the factors described above, the slope of the calibration curve can be adjusted using a factor (refer to section 4.5.1 Calibration of the TURBIDITY (TRB) parameter).

At least a 1-point calibration must be carried out for a solid matter measurement. In difficult application conditions, a 2-point or 3-point calibration may be necessary (refer to section 4.5.2 Calibration of the SOLID (TS) parameter).

4.5.1 Calibration of the TURBIDITY (TRB) parameter

Before the sensor can be calibrated to the TURBIDITY (TRB) parameter, the parameter must be selected.

4.5.1.1 Select TURBIDITY (TRB) parameter

1. Open the MAIN MENU.
2. Press SENSOR SETUP and confirm.
3. Select the corresponding sensor and confirm.
4. Select CONFIGURE and confirm.
5. Press PARAMETERS and confirm.
6. Select the TRB parameter and confirm.
7. Go back to the MAIN MENU or the Measurement mode display.

4.5.1.2 FACTOR

1. Open the MAIN MENU.
2. Press SENSOR SETUP and confirm.
3. Select the corresponding sensor and confirm.
4. Press CALIBRATE and confirm.
5. Press FACTOR and confirm.
6. Set the desired factor and confirm.
7. Go back to the MAIN MENU or the Measurement mode display.

4.5.1.3 OFFSET

1. Open the MAIN MENU.
2. Press SENSOR SETUP and confirm.
3. Select the corresponding sensor and confirm.
4. Press CALIBRATE and confirm.
5. Press OFFSET and confirm.
6. Set the required offset and confirm.
7. Go back to the MAIN MENU or the Measurement mode display.

4.5.1.4 1 to 3 point calibration

Note: The turbidity measurement has been calibrated by the manufacturer.

Note: Before the sensor can be calibrated to the TRB parameter, the parameter must be selected (refer to 4.5.1.1 Select TURBIDITY (TRB) parameter).

1. Open the MAIN MENU.
2. Press SENSOR SETUP and confirm.
3. Select the corresponding sensor and confirm.
4. Press CALIBRATE and confirm.
5. Press CALIBRATE and confirm.
6. Press RECORD and confirm.
7. Press POINT... (point 1, 2 or 3) and confirm.

Once the calibration point has been recorded by the probe, a mark "<<" is displayed after the point or points that has (have) been recorded for approximately 3 seconds.

Note: If the Calibrate menu is closed before the calibration is complete and then called again, the "<<" mark is displayed again. This shows that the calibration for this point or points has not yet been completed. The old calibration values are still being used.

8. Select the recorded POINT parameter and confirm.
9. Enter the laboratory comparison value and confirm.
To record more calibration points: repeat steps 6 to 9.
10. Go back to the MAIN MENU or the Measurement mode display.

The instrument automatically sorts the saved calibration points according to the size of the calibration values, irrespective of the sequence in which the calibration points were recorded.

- Point 1 is always assigned to the smallest calibration value.
- Point 2 is assigned to the next smallest calibration value.
- Point 3 is assigned to the largest calibration value.

The value calculated in the laboratory can be corrected at any time by overwriting.

4.5.2 Calibration of the SOLID (TS) parameter

Before the probe can be calibrated to the SOLID (TS) parameter, the parameter must be selected.

4.5.2.1 Select the SOLID (TS) parameter

1. Open the MAIN MENU.
2. Press SENSOR SETUP and confirm.
3. Select the corresponding sensor and confirm.
4. Select CONFIGURE and confirm.
5. Press PARAMETERS and confirm.
6. Select the parameter TS and confirm.
7. Go back to the MAIN MENU or the Measurement mode display.

4.5.2.2 FACTOR

1. Open the MAIN MENU.
2. Press SENSOR SETUP and confirm.
3. Select the corresponding sensor and confirm.
4. Press CALIBRATE and confirm.
5. Press FACTOR and confirm.
6. Set the desired factor and confirm.
7. Go back to the MAIN MENU or the Measurement mode display.

4.5.2.3 1 to 3 point calibration

Note: It is imperative to calibrate for solid matter measurement (refer to section 4.5.2 Calibration of the SOLID (TS) parameter).

Note: Before the sensor can be calibrated to the TS parameter, the parameter must be selected (refer to 4.5.2.1 Select the SOLID (TS) parameter).

1. Open the MAIN MENU.
2. Press SENSOR SETUP and confirm.
3. Select the corresponding sensor and confirm.
4. Press CALIBRATE and confirm.
5. Press CALIBRATE and confirm.
6. Press RECORD and confirm.
7. Press POINT... (point 1, 2 or 3) and confirm.

Note: Points 2 and 3 are not displayed unless point 1 or points 1 and 2 have already been recorded.

Note: This comparison is made from a grab sample and not a known standard.

Once the calibration point has been recorded by the probe, a mark "<<" is displayed after the point or points that has (have) been recorded for approximately 3 seconds.

Note: If the Calibrate menu is closed before the calibration is complete and then called again, the "<<" mark is displayed again. This shows that the calibration for this point or points has not yet been completed. The old calibration values are still being used.

8. Remove a sample and determine the solid matter content in the laboratory.
9. Select the recorded POINT parameter and confirm.
10. Enter the laboratory comparison value and confirm.

To record more calibration points: repeat steps 6 to 10.

11. Go back to the MAIN MENU or the Measurement mode display.

The instrument automatically sorts the saved calibration points according to the size of the calibration values, irrespective of the sequence in which the calibration points were recorded.

- Point 1 is always assigned to the smallest calibration value.
- Point 2 is assigned to the next smallest calibration value.
- Point 3 is assigned to the largest calibration value.

The value calculated in the laboratory can be corrected at any time by overwriting.

4.5.3 General information about calibration

4.5.3.1 Delete recorded points

Points that have been saved with RECORD can be reset and deleted at any time.

1. Open the MAIN MENU.
2. Press SENSOR SETUP and confirm.
3. Select the corresponding sensor and confirm.
4. Press CALIBRATE and confirm.
5. Press CALIBRATE and confirm.

A mark "<<" is displayed after the recorded point or points for approximately 3 seconds.

6. Press RECORD and confirm.
7. Press CLEAR MEMORY and confirm.

The sensor will continue working with the old calibration values.

8. Go back to the MAIN MENU or the Measurement mode display.

4.5.3.2 Delete a calibration point

An individual calibration point can be deleted at any time by entering the value 0.0 for the concentration.

1. Open the MAIN MENU.
2. Press SENSOR SETUP and confirm.
3. Select the corresponding sensor and confirm.
4. Press CALIBRATE and confirm.
5. Press CALIBRATE and confirm.
6. Select the POINT to be deleted and confirm.
7. Enter the value 0 and confirm.
8. Go back to the MAIN MENU or the Measurement mode display.

Section 5 Maintenance

The cleanliness of the measurement windows in the sensor head is decisive for the accuracy of the measurement results!

Check the measurement windows for dirt and wear once a month.

DANGER

The probe must not be opened. Work on the inside of the probe may only be carried out by the manufacturer.

5.1 Maintenance schedule

Maintenance task	Maintenance interval
Visual inspection	Monthly
Test calibration	Monthly (depending on environmental conditions)
Inspection	Every 6 months (counter)

5.2 Clean the measurement windows

DANGER

The probe (especially the type plate) must not come into contact with acetone or p-Xylene, or any liquids containing these solvents.

DANGER

Potential danger with contact with chemical/biological substances.
Working with chemical samples, standards and reagents can be dangerous.
Make yourself familiar with the necessary safety procedures and the correct handling of the chemicals before use and read and follow all relevant safety data sheets.

CAUTION

Observe safety conditions and wear protective clothing!
Safety glasses
Gloves
Overalls

The windows are made of sapphire glass. The measurement windows can be cleaned with any conventional cleaning agent and a soft cloth.

In the case of stubborn deposits, it is recommended that 5% hydrochloric acid is used.

Section 6 Malfunctions, causes, resolution

6.1 Error messages

Possible sensor error messages are displayed by the sc controller.

Table 1 Error messages

Error displayed	Definition	Resolution
MEAS OVERRANGE	Measurement range exceeded, signals too small, probe can no longer measure this concentration.	If error occurs more frequently: find another installation location.
CAL. INSUFF. –	Calibration insufficient.	Probe requires another calibration point in a lower concentration.
CAL. INSUFF. +	Calibration insufficient.	Probe requires another calibration point in a higher concentration.
ZERO POINT	Calibration is too close to the zero point.	Calibrate again with higher concentration.
CAL REQUIRED	No existing calibration	Calibrate probe.
EE RSRVD ERR	Error in the probe electronics	Call customer service department.
ERROR PROBE	Error in the probe electronics	Call customer service department.
LED FAILURE	Faulty LED	Call customer service department.

6.2 Warning messages

Possible sensor warning messages are displayed by the sc controller.

Table 2 Warnings

Warning displayed	Definition	Resolution
TEST / MAINT	Counter at zero	Call customer service department.

Section 7 Replacement parts and accessories

7.1 Replacement parts

Description	Catalog number
Manual (xx = language code)	DOC023.xx.90171

7.2 Accessories

Description	Catalog number
Stainless Steel pole mount kit, 10 cm base, 2 m pole, 90° adapter	LZY714.99.53120
Stainless Steel pole mount kit, 24 cm base, 2 m pole, 90° adapter	LZY714.99.52120
1.8 m (5.9 ft) extension pipe	LZY714.99.00040
1.0 m (3 ft) extension pipe	LZY714.99.00030
Retractable ball valve armature for TSS EX1 sc TriClamp sensor	LZU301.99.00000
Ball valve armature for TSS EX1 sc Inline, 6 bar, with stainless steel flange	LZY630.00.20000
Ball valve armature for TSS EX1 sc Inline, 6 bar, with carbon steel flange	LZY630.00.21000
Ball valve armature for TSS EX1 sc Inline, 6 bar, without flange	LZY630.00.22000
Silicone gasket for TriClamp fitting	LZY653
PTFE gasket for TriClamp fitting	LZY654
FKM Gasket for TriClamp fitting	LZY655
2-piece clip with thumb screw for TriClamp fitting	LZY656
3-piece clip with thumb screw for TriClamp fitting (for use with PTFE gasket)	LZY657
sc sensor plug	LZX971
Band clamp for grounding of explosion-proof probes	LZI12020
Cable, sensor extension, Class 1, Division 2 Hazardous Location, 1 m (3.3 ft)	6122401
Cable, sensor extension, Class 1, Division 2 Hazardous Location, 7m (23 ft)	5796001
Cable, sensor extension, Class 1, Division 2 Hazardous Location, 15 m (49.21 ft)	5796101
Cable, sensor extension, Class 1, Division 2 Hazardous Location, 31 m (101.71 ft)	5796201
Sensor cable lock for hazardous locations	6139900

Section 8 Limited warranty

Hach Company warrants its products to the original purchaser against any defects that are due to faulty material or workmanship for a period of one year from date of shipment unless otherwise noted in the product manual.

In the event that a defect is discovered during the warranty period, Hach Company agrees that, at its option, it will repair or replace the defective product or refund the purchase price excluding original shipping and handling charges. Any product repaired or replaced under this warranty will be warranted only for the remainder of the original product warranty period.

This warranty does not apply to consumable products such as chemical reagents; or consumable components of a product, such as, but not limited to, lamps and tubing.

Contact Hach Company or your distributor to initiate warranty support. Products may not be returned without authorization from Hach Company.

Limitations

This warranty does not cover:

- Damage caused by acts of God, natural disaster, labor unrest, acts of war (declared or undeclared), terrorism, civil strife or acts of any governmental jurisdiction
- Damage caused by misuse, neglect, accident or improper application or installation
- Damage caused by any repair or attempted repair not authorized by Hach Company
- Any product not used in accordance with the instructions furnished by Hach Company
- Freight charges to return merchandise to Hach Company
- Freight charges on expedited or express shipment of warranted parts or product
- Travel fees associated with on-site warranty repair

This warranty contains the sole express warranty made by Hach Company in connection with its products. All implied warranties, including without limitation, the warranties of merchantability and fitness for a particular purpose, are expressly disclaimed.

Some states within the United States do not allow the disclaimer of implied warranties and if this is true in your state the above limitation may not apply to you. This warranty gives you specific rights, and you may also have other rights that vary from state to state.

This warranty constitutes the final, complete, and exclusive statement of warranty terms and no person is authorized to make any other warranties or representations on behalf of Hach Company.

Limitation of Remedies

The remedies of repair, replacement or refund of purchase price as stated above are the exclusive remedies for the breach of this warranty. On the basis of strict liability or under any other legal theory, in no event shall Hach Company be liable for any incidental or consequential damages of any kind for breach of warranty or negligence.

Appendix A Modbus register

Table 3 Sensor modBUS registers

Tag Name	Group Name	Register	Data Type	Length	R/W	Description
TURBIDITY FNU	Measurement	40001	Float	2	R	Turbidity in FNU
TURBIDITY NTU	Measurement	40001	Float	2	R	Turbidity in NTU
TURBIDITY TEF	Measurement	40001	Float	2	R	Turbidity in TEF
TURBIDITY FTU	Measurement	40001	Float	2	R	Turbidity in FTU
TURBIDITY EBC	Measurement	40003	Float	2	R	Turbidity in EBC
SOLID mg/L	Measurement	40005	Float	2	R	Solid in mg/L
SOLID ppm	Measurement	40005	Float	2	R	Solid in ppm
SOLID g/L	Measurement	40007	Float	2	R	Solid in g/L
SOLID %	Measurement	40009	Float	2	R	Solid in percent
Reserved	Reserved	40011	Unsigned Integer	1	R	Reserved
SET PARAMETER	Configuration	40012	Unsigned Integer	1	R/W	Parameter
UnitTM	Unit	40013	Unsigned Integer	1	R/W	Turbidity Unit
UnitDS	Unit	40014	Unsigned Integer	1	R/W	Solid Unit
OFFSET	Calibration	40015	Float	2	R/W	Turbidity Offset
TRB Factor	Calibration	40017	Float	2	R/W	Turbidity Factor
TS Factor	Calibration	40019	Float	2	R/W	Solid Factor
Reserved	Reserved	40021	Unsigned Integer	1	R	Reserved
RESPONSE TIME	Configuration	40022	Unsigned Integer	1	R/W	Response time
LOGGER INTERVAL	Configuration	40024	Unsigned Integer	1	R/W	Log Interval
Outputmodekal	Service	40025	Unsigned Integer	1	R/W	Calibrate Output Mode
Outputmodesrv	Service	40026	Unsigned Integer	1	R/W	Output Mode Service
EDITED NAME	Configuration	40027	String	8	R/W	Measurement Location
SERIAL NUMBER	Configuration	40036	String	6	R/W	Serial Number
CAL. DATE	Configuration	40042	Time2	2	R	Default Calibration Date
TURBIDITY	Calibration	40044	Float	2	R	Turbidity Sensor Measurement Value
SOLID	Calibration	40046	Float	2	R	Solid Sensor Measurement Value
PROGRAM	Maintenance	40048	Float	2	R	Application Version
BOOTPROGR.	Maintenance	40050	Float	2	R	Bootloader Version
STRUCTURE	Maintenance	40052	Unsigned Integer	1	R	Structure Driver Version
FIRMWARE	Maintenance	40053	Unsigned Integer	1	R	Register Driver Version
CONTENT	Maintenance	40054	Unsigned Integer	1	R	Firmware Driver Version
FormatMinFNU	Configuration	40055	Float	2	R	Turbidity Lower Limit in FNU
FormatMaxFNU	Configuration	40057	Float	2	R	Turbidity Upper Limit in FNU
FormatMinEBC	Configuration	40059	Float	2	R	Turbidity Lower Limit in EBC
FormatMaxEBC	Configuration	40061	Float	2	R	Turbidity Upper Limit in EBC
FormatMinGL	Configuration	40063	Float	2	R	Solid Lower Limit in g/L
FormatMaxGL	Configuration	40065	Float	2	R	Solid Upper Limit in g/L
FormatMinMGL	Configuration	40067	Float	2	R	Solid Lower Limit in mg/L
FormatMaxMGL	Configuration	40069	Float	2	R	Solid Upper Limit in mg/L

Modbus register

Table 3 Sensor modBUS registers (continued)

FormatMinPR	Configuration	40071	Float	2	R	Solid Lower Limit in Percent
FormatMaxPR	Configuration	40073	Float	2	R	Solid Upper Limit in Percent
S5E1	Maintenance	40075	Float	2	R	Signal LED S5E1
S5E3	Maintenance	40077	Float	2	R	Signal LED S5E3
S6E1	Maintenance	40079	Float	2	R	Signal LED S6E1
S6E3	Maintenance	40081	Float	2	R	Signal LED S6E3
S5E2	Maintenance	40083	Float	2	R	Signal LED S5E2
S5E4	Maintenance	40085	Float	2	R	Signal LED S5E4
S6E2	Maintenance	40087	Float	2	R	Signal LED S6E2
S6E4	Maintenance	40089	Float	2	R	Signal LED S6E4

Index

A

Areas of application 8

C

Cable length 6

Calibration

 general information 24

Clean the measurement windows 25

D

Data logger 17

Dimensions 6

Dry matter measurement 9

E

Error messages 27

M

Maintenance schedule 25

Measurement

 accuracy 5

 method 5

 range 5

Measuring principle 9

R

Reproducibility 5

Response time 5

S

Safety information 7

Scope of delivery 9

Specifications 5

System configuration 17

T

Turbidity measurement 9

W

Warning labels 8

Warnings 27

Warranty 31

Warranty and liability 31

HACH COMPANY World Headquarters

P.O. Box 389, Loveland, CO 80539-0389 U.S.A.
Tel. (970) 669-3050
(800) 227-4224 (U.S.A. only)
Fax (970) 669-2932
orders@hach.com
www.hach.com

HACH LANGE GMBH

Willstätterstraße 11
D-40549 Düsseldorf, Germany
Tel. +49 (0) 2 11 52 88-320
Fax +49 (0) 2 11 52 88-210
info-de@hach.com
www.de.hach.com

HACH LANGE Sàrl

6, route de Compois
1222 Vézenaz
SWITZERLAND
Tel. +41 22 594 6400
Fax +41 22 594 6499

