



DOC023.52.90716

BioTector B3500dw Online TOC Analyzer

Maintenance and Troubleshooting

07/2024, Edition 3

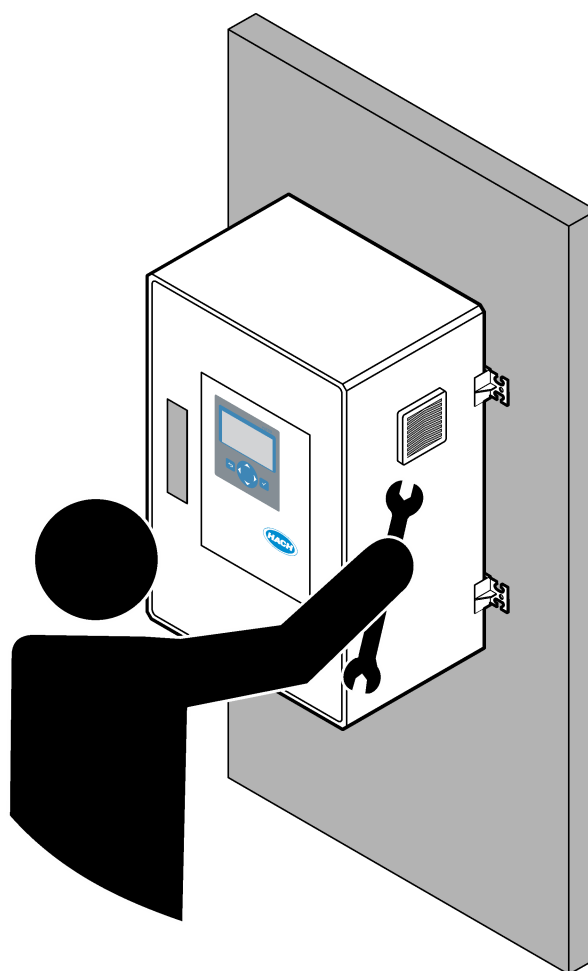

Section 1 Maintenance	3
1.1 Safety information.....	3
1.1.1 Safety symbols and markings.....	3
1.1.2 Use of hazard information.....	4
1.1.3 Electrical safety precautions.....	4
1.1.4 Ozone precautions.....	4
1.2 Maintenance schedule.....	5
1.3 Weekly maintenance.....	5
1.4 Fill or replace the reagents.....	6
1.5 Open the door.....	6
1.6 Replace a fuse.....	7
1.7 Shutdown procedure.....	11
1.7.1 Flush the reagent lines.....	11
Section 2 Troubleshooting	13
2.1 System Faults.....	13
2.2 System warnings.....	15
2.3 Notifications.....	21
2.4 Show the status history before a fault.....	21
Section 3 Diagnostics	23
3.1 Do a pressure test.....	23
3.2 Do a flow test.....	23
3.3 Do an ozone test.....	24
3.4 Do a sample pump test.....	24
3.5 Do a pH test.....	25
3.6 Do simulations.....	26
3.7 Do a relay or 4–20 mA output test.....	28
3.8 Show the input and output status.....	29
3.9 Show the oxygen controller status.....	29
3.10 Show the Modbus status.....	30
3.11 Modbus troubleshooting.....	31
Section 4 Analysis enclosure	33
Section 5 Replacement parts and accessories	39

Section 1 Maintenance

⚠ DANGER



Multiple hazards. Only qualified personnel must conduct the tasks described in this section of the document.

1.1 Safety information

Please read this entire manual before maintenance tasks or troubleshooting is done on this equipment. Pay attention to all danger and caution statements. Failure to do so could result in serious injury to the operator or damage to the equipment.

Make sure that the protection provided by this equipment is not impaired. Do not use or install this equipment in any manner other than that specified in this manual.



1.1.1 Safety symbols and markings

Read all labels and tags attached to the instrument. Personal injury or damage to the instrument could occur if not observed. A symbol on the instrument is referenced in the manual with a precautionary statement.

The safety symbols and marking that follow are used on the equipment and in the product documentation. The definitions are in the table that follows.

	Caution/Warning. This symbol identifies that an appropriate safety instruction should be followed or a potential hazard exists.
	Hazardous voltage. This symbol indicates that hazardous voltages are present where a risk of electrical shock exists.
	Hot surface. This symbol indicates that the marked item can be hot and should not be touched without care.
	Corrosive substance. This symbol identifies the presence of a strong corrosive or other hazardous substance and a risk of chemical harm. Only individuals qualified and trained to work with chemicals should handle chemicals or perform maintenance on chemical delivery systems associated with the equipment.
	Toxic. This symbol indicates a toxic/poisonous substance hazard.
	This symbol indicates the presence of devices sensitive to Electro-static Discharge (ESD) and indicates that care must be taken to prevent damage with the equipment.
	This symbol indicates a flying debris hazard.
	Protective earth. This symbol indicates a terminal which is intended for connection to an external conductor for protection against electric shock in case of a fault (or the terminal of a protective earth (ground) electrode).
	Noiseless (clean) earth. This symbol indicates a functional earthing (grounding) terminal (e.g., a specially designed earthing (grounding) system) to avoid a malfunction of the equipment.
	This symbol indicates an inhalation hazard.
	This symbol indicates there is a lifting hazard because the object is heavy.

Maintenance

	This symbol indicates a fire hazard.
	Electrical equipment marked with this symbol may not be disposed of in European domestic or public disposal systems. Return old or end-of-life equipment to the manufacturer for disposal at no charge to the user.

1.1.2 Use of hazard information

The alert boxes that follow are used in this document to indicate important instructions for the safe operation of the equipment.

DANGER

Indicates a potentially or imminently hazardous situation which, if not avoided, will result in death or serious injury.

WARNING

Indicates an instruction for a potentially hazardous situation that may result in death or a serious injury.

CAUTION

Indicates that a precaution must be followed for a potentially hazardous situation that may result in minor or moderate injury.

NOTICE

Indicates a situation which, if not avoided, may cause damage to the instrument. Information that requires special emphasis.

1.1.3 Electrical safety precautions

The power supplies in the electrical enclosure contain capacitors that are charged to hazardous voltages. After the main power is disconnected, let the capacitors discharge (1 minute minimum) before the electrical enclosure is opened.

1.1.4 Ozone precautions

CAUTION



Ozone inhalation hazard. This instrument produces ozone that is contained within the equipment, specifically within the internal plumbing. The ozone could be released under fault conditions.

It is recommended to plumb the exhaust gas port to a fume hood or to the building exterior in accordance with local, regional and national requirements.

Exposure to even low concentrations of ozone can damage delicate nasal, bronchial and pulmonary membrane. In sufficient concentration, ozone can cause headaches, coughing, eye, nose and throat irritation. Immediately, move the victim to uncontaminated air and seek first aid.

The type and harshness of symptoms are based on the concentration and exposure time (n). Ozone poisoning includes one or more of the symptoms that follow.

- Irritation or burning of the eyes, nose or throat
- Lassitude
- Frontal headache
- Sensation of sub-sternal pressure
- Constriction or oppression

- Acid taste in mouth
- Asthma

In case of more severe ozone poisoning, the symptoms can include dyspnea, cough, choking sensation, tachycardia, vertigo, lowering of blood pressure, cramping, chest pain, and generalized body pain. Ozone can cause a pulmonary oedema one or more hours after exposure.

1.2 Maintenance schedule

NOTICE
To prevent instrument damage, weekly maintenance must be done by a Hach trained operator or Hach trained maintenance personnel.
To prevent instrument damage, 6-month maintenance and troubleshooting must be done by Hach trained maintenance personnel.

Table 1 shows the recommended schedule of maintenance tasks. Facility requirements and operating conditions may increase the frequency of some tasks.

Table 1 Maintenance schedule

Task	1 week	6 months	12 months	As necessary
Weekly maintenance on page 5	X			
6-month maintenance ¹		X		
Fill or replace the reagents on page 6				X
Replace a fuse on page 7				X
Shutdown procedure on page 11				X

1.3 Weekly maintenance

Use the checklist that follows to complete weekly maintenance. Do the tasks in the order given.

Task	Initial
Make sure that the instrument air pressure supplied to the analyzer is correct. <ul style="list-style-type: none"> • Instrument air plumbed to analyzer—1.5 bar • BioTector compressor plumbed to analyzer—1.2 bar 	
Select MAINTENANCE > DIAGNOSTICS > SIMULATE. Select MFC. Set the flow to 20 L/h. Push ✓ to start the mass flow controller (MFC). The measured flow shows on the display.	
Make sure that the oxygen pressure regulator shows 400 mbar at 20 L/h. Refer to Analysis enclosure on page 33 for the location.	
Make sure that the reagent levels are sufficient. Fill or replace reagent containers as necessary. Refer to Fill or replace the reagents on page 6.	
Make sure that there are no leaks at the reagent pumps. Refer to Analysis enclosure on page 33 for the location.	
Make sure that there are no leaks at the sample pump.	

¹ Refer to the documentation supplied with the maintenance kit for instructions.

Maintenance

Task	Initial
Make sure that there are no leaks at the valves in the analyzer. Refer to Analysis enclosure on page 33 for the location.	
Make sure that there are no blockages in the sample lines to the analyzer or the sample lines in the analyzer.	
Make sure that there are no blockages in the drain lines from the analyzer or the drain lines in the analyzer.	
Make sure that there is no blockage in the exhaust tubing.	
Make sure that there are no blockages in the filter in the fan housing and the vent housing on the side of the analyzer.	

1.4 Fill or replace the reagents

⚠ CAUTION



Chemical exposure hazard. Obey laboratory safety procedures and wear all of the personal protective equipment appropriate to the chemicals that are handled. Refer to the current safety data sheets (MSDS/SDS) for safety protocols.

⚠ CAUTION



Chemical exposure hazard. Dispose of chemicals and wastes in accordance with local, regional and national regulations.

Fill or replace the acid and base reagent containers as necessary when the analyzer is stopped.

1. Select OPERATION > START, STOP > FINISH & STOP or EMERGENCY STOP.
2. Fill or replace the reagents.
3. Select MAINTENANCE > COMMISSIONING > REAGENTS MONITOR.
4. Set the reagents volumes.
5. Select OPERATION > REAGENTS SETUP > INSTALL NEW REAGENTS to prime the reagent tubing and do a zero calibration.

1.5 Open the door

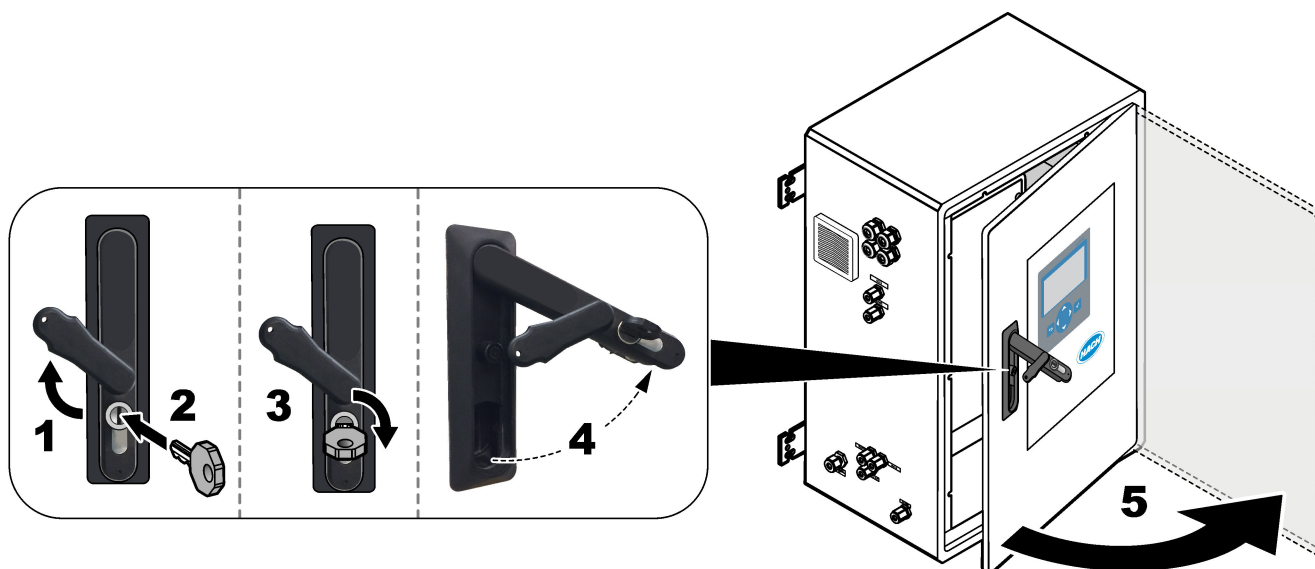

1.6 Replace a fuse

⚠ DANGER



Electrocution hazard. Isolate all power to the instrument and disconnect all power from the instrument and relay connections before this maintenance task is started

⚠ DANGER



Electrocution hazard. Use the same type and current rating to replace fuses.

Replace a blown fuse for correct operation.

1. Remove power to the analyzer. Refer to the illustrated steps in [Figure 1](#).
2. Replace the fuse. Refer to [Figure 2](#) and [Figure 3](#).
Refer to [Figure 4](#) for the fuse specifications.

Figure 1 Remove power to the analyzer

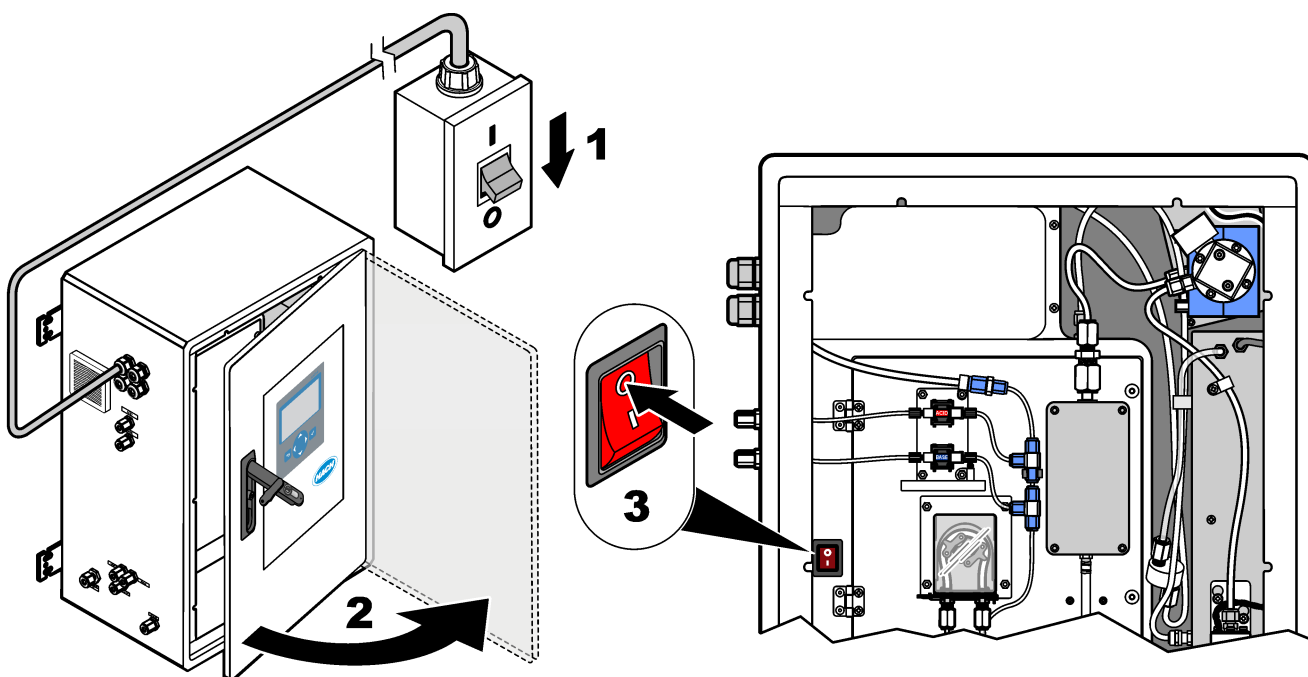

Figure 2 Replace a fuse on the Power and Input/Output Board

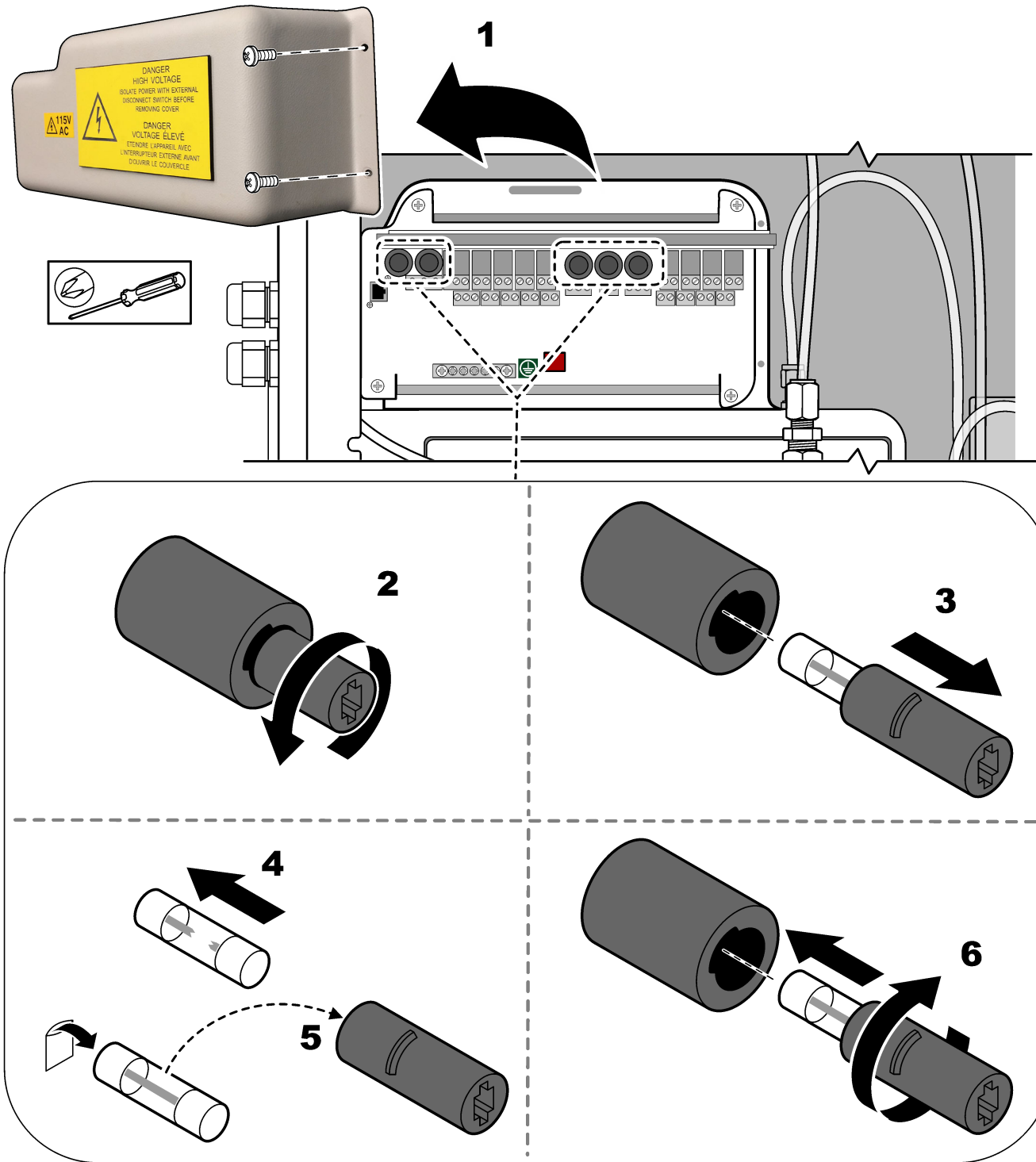

Figure 3 Replace a fuse on the motherboard

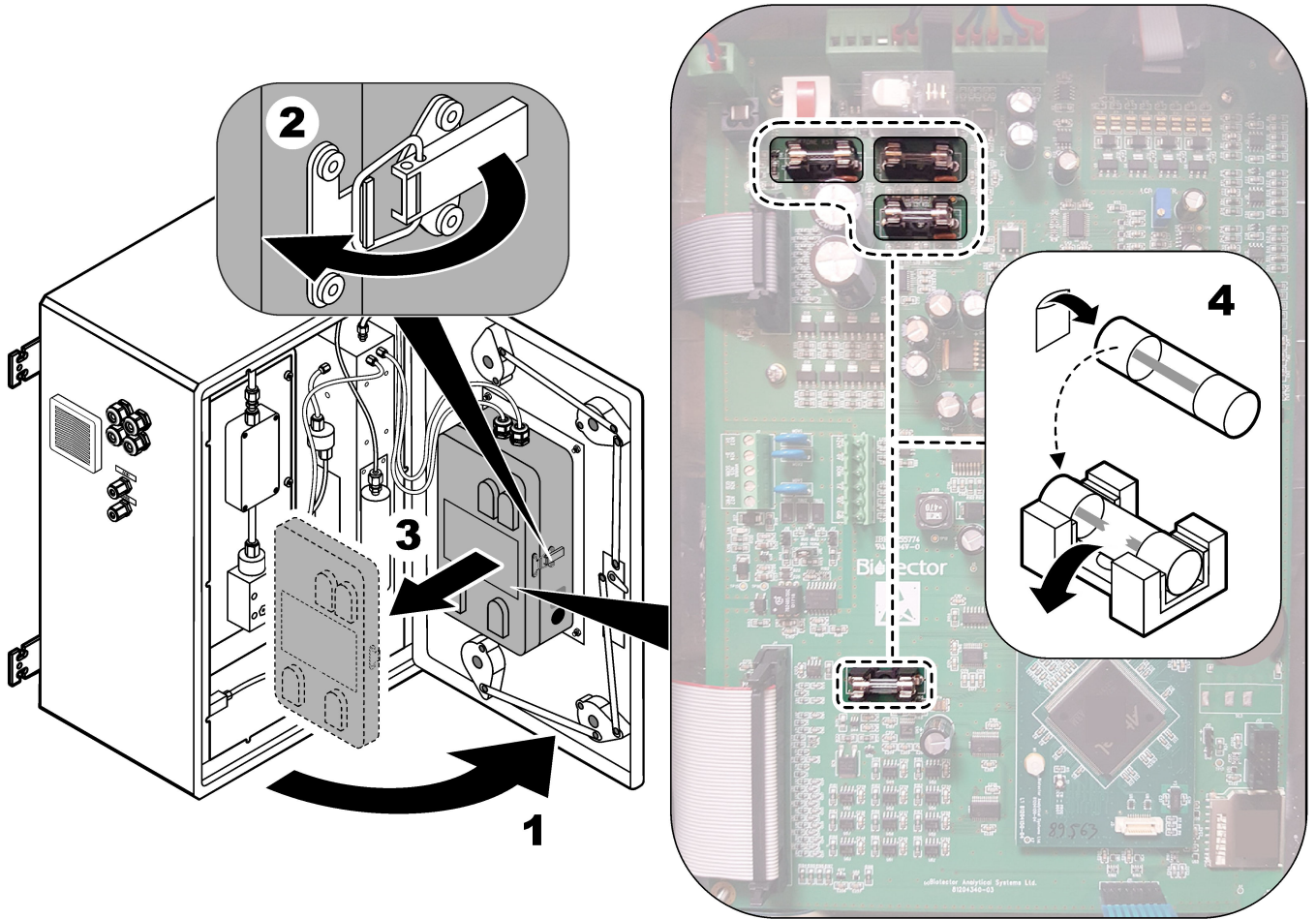
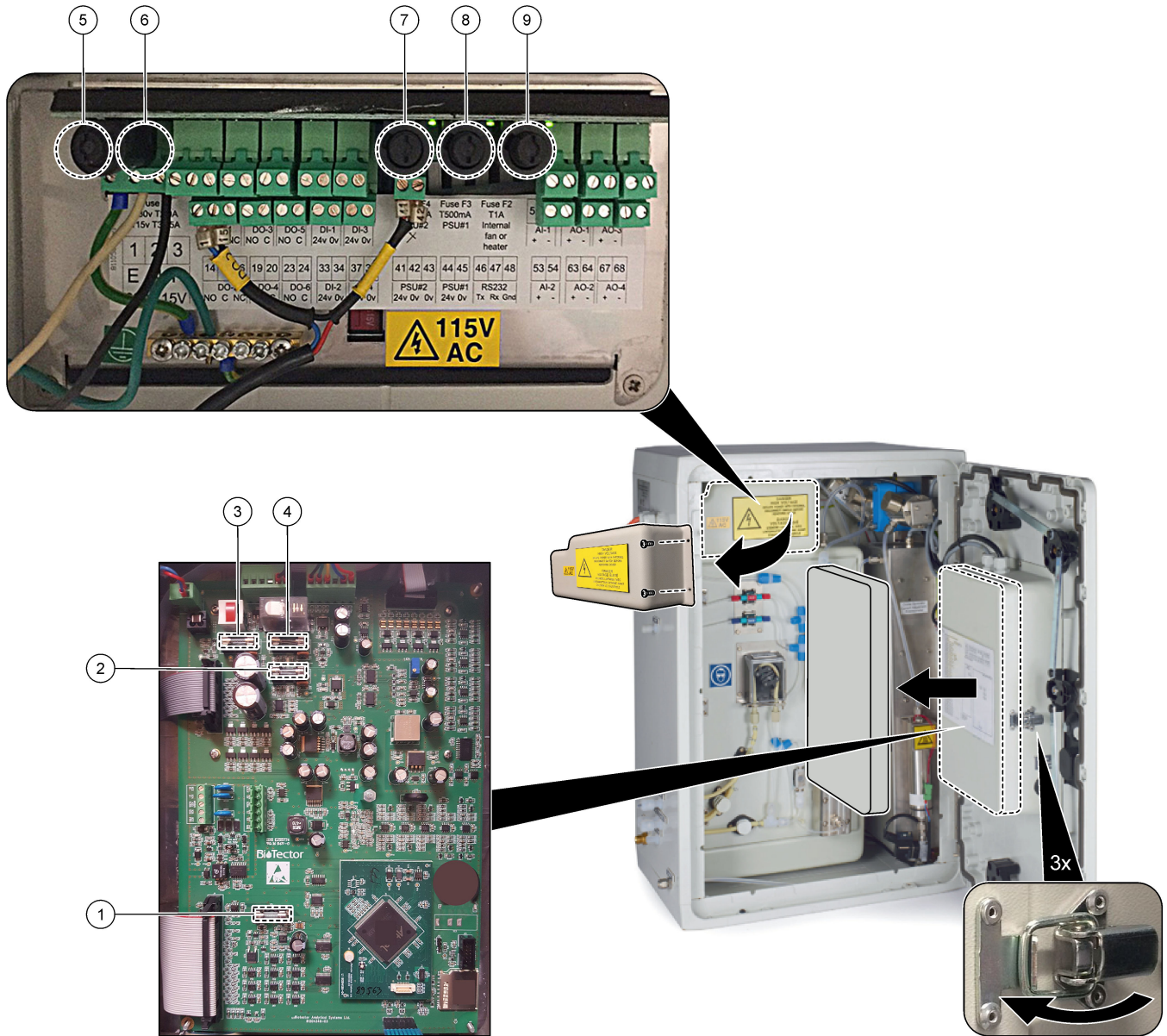

Figure 4 Fuse specifications



Item	Location	Fuse	Rating	Type	Material	Size
1	Motherboard 81204340_xx	F3	2 A	F 2A L250V DC	Glass	Miniature 5 x 20 mm
2		F5	3.15 A	F 3.15A L250V DC		
3		F2	1.6 A	F 1.6A L250V DC		
4		F4	2.5 A	F 2.5A L250V DC		
5	Power and Input/Output Board 81204350-xx	F1	230 V: 2 A 115 V: 3.15 A	230 V: T 2A H250V 115 V: T 3.15A H250V	Ceramic	Miniature 5 x 20 mm
6		F2	230 V: 2 A 115 V: 3.15 A	230 V: T 2A H250V 115 V: T 3.15A H250V		
7, 8		F3, F4	0.5 A	T 0.5mA H250V		
9		F5	1 A	T 1A H250V		

Key:

- A—Amperes
- F1-5—Fuse
- F—Fast acting (fast blow)
- H—High interrupt
- ID—Identification
- L— Low interrupt
- mA—Milliamperes
- PCB—Printed circuit board
- T—Time lag (time delay)
- V—Volts

1.7 Shutdown procedure

If power will be removed from the analyzer for more than 2 days, use the checklist that follows to prepare the analyzer for shutdown or storage. Do the tasks in the order given.

Task	Initial
Select OPERATION > START, STOP > FINISH & STOP or EMERGENCY STOP.	
Wait for the display to show "SYSTEM STOPPED".	
Remove the reagent from the reagent lines for safety. Refer to Flush the reagent lines on page 11.	
Disconnect the SAMPLE fittings from the sample sources. Connect the SAMPLE fittings to an open drain or empty plastic container.	
Remove power to the analyzer.	

1.7.1 Flush the reagent lines

⚠ CAUTION



Chemical exposure hazard. Obey laboratory safety procedures and wear all of the personal protective equipment appropriate to the chemicals that are handled. Refer to the current safety data sheets (MSDS/SDS) for safety protocols.

⚠ CAUTION



Chemical exposure hazard. Dispose of chemicals and wastes in accordance with local, regional and national regulations.

Remove the reagent from the reagent lines for safety.

1. Put on the personal protective equipment identified in the safety data sheets (MSDS/SDS).
 2. Remove the tubes from the ACID and BASE ports on the side of the analyzer. Refer to [Figure 5](#).
 3. Plumb the ACID and BASE ports to a deionized water container. If deionized water is not available, use tap water.
 4. Select CALIBRATION > ZERO CALIBRATION > RUN REAGENTS PURGE to start a purge cycle.
 5. If the reagent tubing does not fill with deionized water during the reagents purge cycle, hold the deionized water container higher than the analyzer and do step 4.
 6. Do step 4 a second time.
- The analyzer replaces the reagents in the reagents lines with water.

Maintenance

7. When the reagent purge cycle is complete, remove the tubing from the deionized water container and put them in open air.
8. Do step 4 two times.
The analyzer replaces the water in the reagents lines with air.

Figure 5 Connect deionized water to the reagent fittings

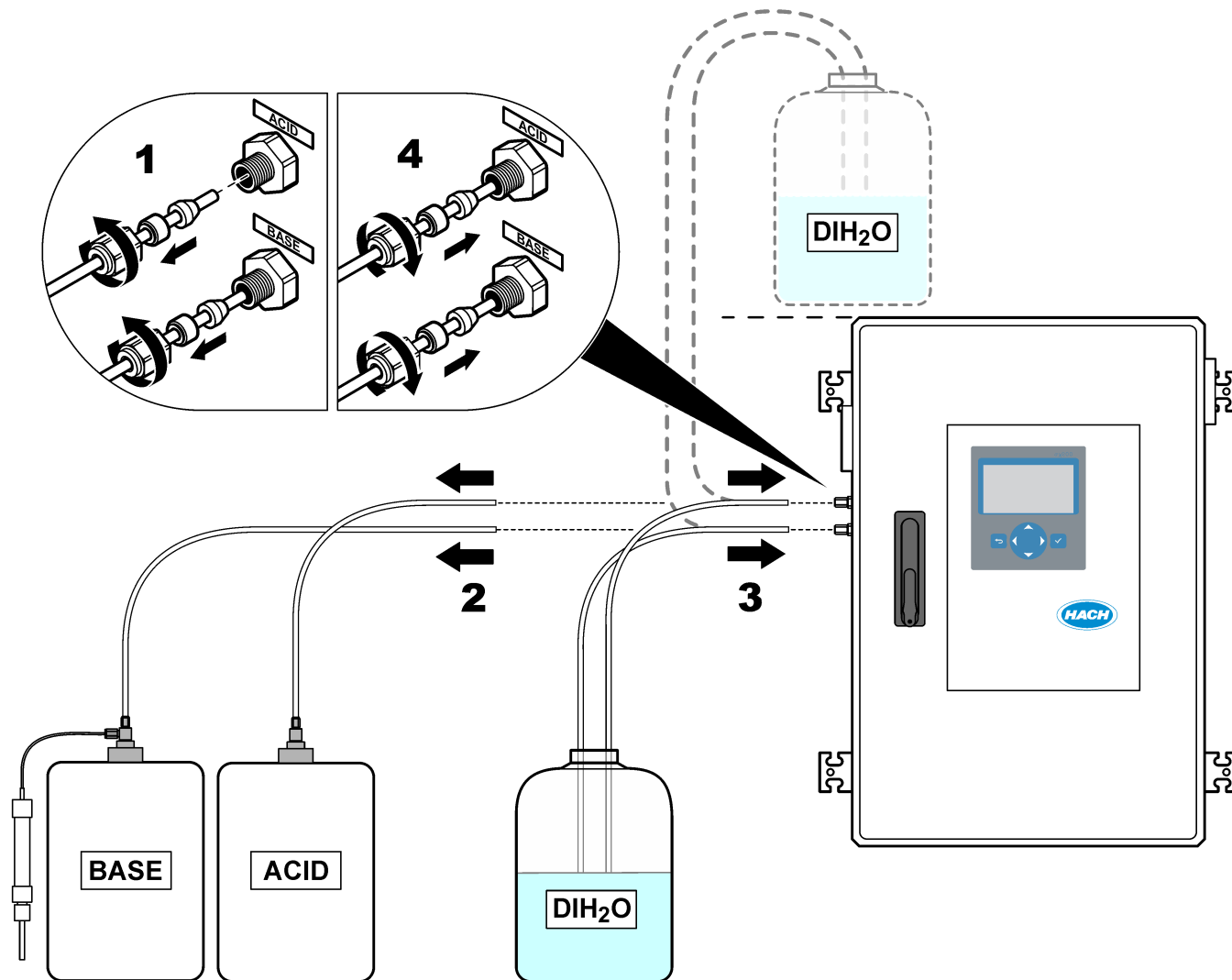

Section 2 Troubleshooting

2.1 System Faults

If the display is not on when the main power switch is set to on and power is supplied to the analyzer, replace F2 on the motherboard. Refer to [Replace a fuse](#) on page 7.

Select OPERATION > FAULT ARCHIVE to see the system faults that have occurred. Faults and warnings with an asterisk (*) are active.

When "SYSTEM FAULT" shows in the top-left corner of the Reaction Data screen or the Reagent Status screen, a system fault has occurred. Measurements have stopped. The 4–20 mA outputs are set to the fault level (default: 1 mA). The system fault relay is set to on.

To start the analyzer again, complete the troubleshooting steps for the system fault. Refer to [Table 2](#). To acknowledge the fault, select the fault and push ✓.

Note: There are system faults (e.g., 05_Pressure Test Fail) that cannot be acknowledged by the user. These faults are reset and acknowledged automatically by the system when the system is started, the system is rebooted or when the fault condition is removed.

Table 2 System Faults

Message	Description	Cause and solution
01_LOW O2 FLOW - EX	The oxygen flow through the exhaust (EX) valve (MV1) was less than 50% of the oxygen flow MFC (mass flow controller) setpoint for more than the LOW O2 FLOW TIME setting. Refer to MAINTENANCE > SYSTEM CONFIGURATION > FAULT SETUP > LOW O2 FLOW TIME.	<ul style="list-style-type: none"> Oxygen supply problem. The oxygen pressure should be 400 mbar (± 10 mbar) at 20 L/h MFC flow. Select MAINTENANCE > DIAGNOSTICS > O2-CTRL STATUS. Blockage in the ozone destructor Blockage in the tube after the MFC Failure of or blockage in the exhaust valve Failure of the MFC. Do a flow test. Refer to Do a flow test on page 23.
02_LOW O2 FLOW - SO	The oxygen flow through the Sample Out (SO) fitting (through the reactor valve, MV3) was less than 50% of the MFC setpoint for more than the LOW O2 FLOW TIME setting. Refer to MAINTENANCE > SYSTEM CONFIGURATION > FAULT SETUP > LOW O2 FLOW TIME.	<ul style="list-style-type: none"> Oxygen supply problem. The oxygen pressure should be 400 mbar (± 10 mbar) at 20 L/h MFC flow. Select MAINTENANCE > DIAGNOSTICS > O2-CTRL STATUS. Failure of or blockage in the sample out valve Failure of or blockage in the exhaust valve (MV1) Failure of the MFC. Do a flow test. Refer to Do a flow test on page 23.
03_HIGH O2 FLOW	The oxygen flow through the exhaust valve (MV1) was more than 50% of the MFC setpoint for more than the HIGH O2 FLOW TIME setting. Refer to MAINTENANCE > SYSTEM CONFIGURATION > FAULT SETUP > HIGH O2 FLOW TIME.	<ul style="list-style-type: none"> Failure of the MFC Oxygen supply problem. The oxygen pressure should be 400 mbar (± 10 mbar) at 20 L/h MFC flow. Select MAINTENANCE > DIAGNOSTICS > O2-CTRL STATUS.
04_REACTION ERROR (can be set as a fault or warning)	No TOC CO ₂ peak or the CO ₂ peak is less than the CO ₂ LEVEL setting for three consecutive reactions. Refer to MAINTENANCE > SYSTEM CONFIGURATION > REACTION CHECK > CO ₂ LEVEL.	<ul style="list-style-type: none"> The acid reagent and/or base reagent are the incorrect concentration. The acid reagent container and/or base reagent container are empty. The acid and/or base reagent lines have a blockage or air bubbles. The operation of the acid pump and/or base pump is incorrect. The operation of the mixer reactor is incorrect. Do a pH test. Refer to Do a pH test on page 25.

Table 2 System Faults (continued)

Message	Description	Cause and solution
05_PRESSURE TEST FAIL	The MFC flow did not decrease to less than the PRESSURE TEST FAULT setting during the pressure test. Refer to MAINTENANCE > SYSTEM CONFIGURATION > SEQUENCE PROGRAM > PRESSURE/FLOW TEST > PRESSURE TEST FAULT.	<ul style="list-style-type: none"> The analyzer has a gas and/or liquid leak. A valve has a leak. Open the reactor valve. Inspect for dirt and damage. Inspect the system fittings. Examine the mixer reactor for leaks. Do a pressure test. Refer to Do a pressure test on page 23.
06_PRESSURE CHCK FAIL	The MFC flow did not decrease to less than the PRESSURE CHCK FAULT setting during the pressure check for three consecutive reactions (default). Refer to MAINTENANCE > SYSTEM CONFIGURATION > SEQUENCE PROGRAM > PRESSURE/FLOW TEST > PRESSURE CHCK FAULT.	
11_CO2 ANALYZER FAULT	The operation of the CO ₂ analyzer is incorrect.	Examine the 24V DC input power to the CO ₂ analyzer from the motherboard (wires N11 and N12). Examine the signal from the CO ₂ analyzer. Open the CO ₂ analyzer and clean the lenses. Remove and then apply power to the analyzer. For more tests, refer to the information sheet <i>T019. BioTector CO₂ Analyzer Troubleshooting</i> .
12_HIGH CO2 IN O2	There is a high level of CO ₂ in the input oxygen gas.	Select MAINTENANCE > DIAGNOSTICS > SIMULATE. If the CO ₂ value on the display is more than 250 to 300 ppm, examine the oxygen purity. Identify if there is CO ₂ contamination in the oxygen supply. Refer to <i>Examine the oxygen supply</i> in the Operation and Installation Manual. If the oxygen purity is sufficient, open the CO ₂ analyzer and clean the lenses. If the problem continues, replace the CO ₂ analyzer filters. If the oxygen purity is not satisfactory, replace the oxygen concentrator.
18_LIQUID LEAK DET	A liquid leak detector in the analyzer is active. There is a liquid leak.	Look for a liquid leak in the analyzer enclosure. Examine the liquid leak detectors. There are four liquid leak detectors: <ul style="list-style-type: none"> Bottom of the main cabinet Bottom of the inner cabinet Bottom of the mixer reactor Below the acid and base pumps Disconnect the leak detector connector on the bottom of the reactor to identify if the reactor has a leak. Examine the liquid leak detector.
20_NO REAGENTS (can be set as a fault, warning or notification)	The calculated reagent levels identify that the reagent containers are empty.	Replace the reagents. Refer to Fill or replace the reagents on page 6.
104_MOTHERBOARD FUSE4	Fuse 4 is blown on the motherboard. Note: Fuse 4 is for the cooler and ozone generator.	If Fuse 4 (F4) is blown, replace the fuse. Refer to Replace a fuse on page 7. Make sure the fuse is fully in the fuse holder.

Table 2 System Faults (continued)

Message	Description	Cause and solution
105_MOTHERBOARD FUSE5	Fuse F5 is blown on the motherboard. <i>Note: F5 is for the pumps, valves, mixer reactor, cooler fan, ozone destructor and ozone generator fan.</i>	If Fuse 5 (F5) is blown, replace the fuse. Refer to Replace a fuse on page 7. Make sure the fuse is fully in the fuse holder. Select MAINTENANCE > DIAGNOSTICS > SIMULATE. Operate each device connected to F5. F5 is connected to the pumps, valves, mixer reactor, cooler fan, ozone destructor and ozone generator fan.
109_HI MPU TEMP	The temperature of the MPU (micro processor unit) is more than 70 °C (158 °F).	Examine the filters in the fan and vent. Examine the operation of the fan. Make sure that the ambient temperature is less than 45 °C (113 °F) and the analyzer is not in direct sunlight. <i>Note: At temperatures less than 25 °C (77 °F), the analyzer sets the fan to off.</i>
129_REACT PURGE FAIL	There is a blockage in the reactor, reactor valve (MV3), sample valve (MV4) or the related tubing and fittings. The MFC operation is not correct or the MFC tubing has a blockage. Refer to REACTOR PURGE CHECK and REACTOR PURGE BAND in <i>Configure the pressure test and flow test settings</i> in the advanced configuration manual.	There is an air or oxygen supply problem. Look at the O2-CTRL STATUS menu to examine the oxygen pressure. The pressure is usually 400 mbar (±10 mbar) at 20 L/h MFC flow. Do a flow test. Refer to Do a flow test on page 23.

2.2 System warnings

Select OPERATION > FAULT ARCHIVE to see the warnings that have occurred. Faults and warnings with an asterisk (*) are active.

When "SYSTEM WARNING" shows in the top-left corner of the Reaction Data screen or the Reagent Status screen, a warning occurred. Measurements continue. The 4-20 mA outputs do not change. The system fault relay is not set to on.

Complete the troubleshooting steps for the warning. Refer to [Table 3](#). To acknowledge the warning, select the warning and push ✓.

If there are multiple warnings in the instrument, examine the fuses on the relay board and signal board.

Table 3 System warnings

Message	Description	Cause and solution
21_CO2 ANL LENS DIRTY	The optical device of the CO ₂ analyzer is dirty.	Clean the CO ₂ analyzer. Clean the lenses in the CO ₂ analyzer.
22_FLOW WARNING – EX	The oxygen flow through the exhaust (EX) valve (MV1) decreased to less than the FLOW WARNING setting during the pressure test. Refer to MAINTENANCE > SYSTEM CONFIGURATION > SEQUENCE PROGRAM > PRESSURE/FLOW TEST > FLOW WARNING.	<ul style="list-style-type: none"> Oxygen supply problem. The oxygen pressure should be 400 mbar (±10 mbar) at 20 L/h MFC flow. Select MAINTENANCE > DIAGNOSTICS > O2-CTRL STATUS. Blockage in the ozone destructor Blockage in the tube after the mass flow controller (MFC) Failure of or blockage in the exhaust valve Failure of the MFC. Do a flow test. Refer to Do a flow test on page 23.

Table 3 System warnings (continued)

Message	Description	Cause and solution
23_FLOW WARNING – SO	The oxygen flow through the Sample Out fitting (through the reactor valve, MV3) decreased to less than the FLOW WARNING setting during the pressure test. Refer to MAINTENANCE > SYSTEM CONFIGURATION > SEQUENCE PROGRAM > PRESSURE/FLOW TEST > FLOW WARNING.	<ul style="list-style-type: none"> Oxygen supply problem Failure of or blockage in the sample out valve Blockage in the tube after MFC Failure of the MFC. Do a flow test. Refer to Do a flow test on page 23.
26_PRESSURE TEST WARN	The MFC flow did not decrease to less than the PRESSURE TEST WARN setting during the pressure test. Refer to MAINTENANCE > SYSTEM CONFIGURATION > SEQUENCE PROGRAM > PRESSURE/FLOW TEST > PRESSURE TEST WARN.	<ul style="list-style-type: none"> The analyzer has a gas and/or liquid leak. A valve has a leak. Open the reactor valve. Inspect for dirt and damage. Inspect the system fittings. Examine the mixer reactor for leaks. Do a pressure test. Refer to Do a pressure test on page 23.
28_NO PRESSURE TEST	The pressure test was not done during the system startup sequence. <i>Note: The warning stays active until a pressure test is passed.</i>	The analyzer was started with a quick startup. The RIGHT arrow key was pushed when START was selected.
29_PRESSURE TEST OFF	The daily pressure test and flow test functions are set to off.	Set the pressure test and flow test functions to on in the MAINTENANCE > SYSTEM CONFIGURATION > SEQUENCE PROGRAM > PRESSURE/FLOW TEST menu.
30_TOC SPAN CAL FAIL 31_TIC SPAN CAL FAIL	The result of the TIC or TOC span calibration is not within the TIC BAND or TOC BAND setting. Refer to MAINTENANCE > SYSTEM CONFIGURATION > SEQUENCE PROGRAM > SPAN PROGRAM > TIC BAND or TOC BAND.	Make sure that the concentration of the prepared standard solution is correct. Make sure that the settings in the CALIBRATION > SPAN CALIBRATION menu are correct. Examine the operation of the analyzer.
33_TOC SPAN CHCK FAIL 34_TIC SPAN CHCK FAIL	The result of the TIC or TOC span check is not within the TIC BAND or TOC BAND setting. Refer to MAINTENANCE > SYSTEM CONFIGURATION > SEQUENCE PROGRAM > SPAN PROGRAM > TIC BAND or TOC BAND.	
42_ZERO CAL FAIL	The zero calibration result is not within the ZERO BAND setting. Refer to MAINTENANCE > SYSTEM CONFIGURATION > SEQUENCE PROGRAM > ZERO PROGRAM > ZERO BAND.	<p>Examine the stability of the zero reactions and the quality of the reagents.</p> <p>Examine the settings in the ZERO PROGRAM menu.</p> <p>Do a zero calibration. Refer to the Installation and Operation Manual.</p>
43_ZERO CHCK FAIL	The zero check result is not within the ZERO BAND setting. Refer to MAINTENANCE > SYSTEM CONFIGURATION > SEQUENCE PROGRAM > ZERO PROGRAM > ZERO BAND.	

Table 3 System warnings (continued)

Message	Description	Cause and solution
50_TIC OVERFLOW	<p>The TIC reading at the end of the TIC analysis is more than the TIC CHECK setting. In addition the TIC reading is more than the TIC CHECK setting after the TIC sparge time was increased 300 seconds.</p> <p>Refer to MAINTENANCE > SYSTEM CONFIGURATION > REACTION CHECK > TIC CHECK.</p>	<p>Unusually high TIC reading.</p> <p>Increase the TIC SPARGE TIME setting. Refer to MAINTENANCE > SYSTEM CONFIGURATION > OXIDATION PROGRAM 1 > TIC SPARGE TIME.</p>
51_TOC OVERFLOW	<p>The TOC reading at the end of the TIC analysis is more than the TOC CHECK setting, even after the TOC sparge time was increased 300 seconds.</p> <p>Refer to MAINTENANCE > SYSTEM CONFIGURATION > REACTION CHECK > TOC CHECK.</p>	<p>Unusually high TOC reading.</p> <p>Increase the TOC SPARGE TIME setting. Refer to MAINTENANCE > SYSTEM CONFIGURATION > OXIDATION PROGRAM 1 > TOC SPARGE TIME.</p>
52_HIGH CO2 IN BASE	<p>The CO₂ level in the base reagent is more than the BASE CO2 ALARM setting.</p> <p>Refer to MAINTENANCE > SYSTEM CONFIGURATION > FAULT SETUP > BASE CO2 ALARM.</p> <p>Note: The CO₂ level in the base reagent is identified during a zero calibration or zero check.</p>	<p>Make sure that the CO₂ filter on the base reagent container is in good condition. Make sure that the base reagent container has no air leak. Identify the quality of the base reagent. Replace the base reagent.</p>
62_SMPL PUMP STOP ON	<p>The sample pump stopped with its rotation sensor set to on or the operation of the rotation sensor is incorrect (continuously on).</p>	<p>Examine the rotation of the sample pump.</p> <p>Examine the pump sensor signal. Look at DI15 in DIGITAL INPUT menu. Refer to MAINTENANCE > DIAGNOSTICS > INPUT/OUTPUT STATUS > DIGITAL INPUT.</p>
63_SMPL PUMP STOP OFF	<p>The sample pump stopped with its rotation sensor set to off or the operation of the rotation sensor is incorrect (no rotation sensed).</p>	<p>Replace the sample pump. Refer to Replacement parts and accessories on page 39</p>
81_ATM PRESSURE HIGH	<p>The reading of the atmospheric pressure sensor is more than 115 kPa. The atmospheric pressure sensor reading is set to 101.3 kPa (fault operation mode).</p>	<p>Examine ADC[05] in the ANALOG INPUT menu. Refer to MAINTENANCE > DIAGNOSTICS > INPUT/OUTPUT STATUS > ANALOG INPUT. The reading should be approximately 4 V.</p> <p>The operation of the pressure sensor is incorrect.</p>
82_ATM PRESSURE LOW	<p>The reading of the atmospheric pressure sensor is less than 60 kPa. The atmospheric pressure sensor reading is set to 101.3 kPa (fault operation mode).</p>	<p>Replace the motherboard. Refer to Replacement parts and accessories on page 39</p>
83_SERVICE TIME	<p>Service is necessary</p>	<p>Complete the necessary service tasks. Then, reset the service counter to acknowledge the warning. Select MAINTENANCE > DIAGNOSTICS > SERVICE > RESET SERVICE COUNTER.</p>

Table 3 System warnings (continued)

Message	Description	Cause and solution
88_O2 CONTROLLER WARN	There is a communication problem between the motherboard and the O ₂ Controller Board.	<p>Make sure that LED 2 (L2) on the O₂ Controller Board is on.</p> <p>Examine the 24 VDC power on the O₂ Controller board at terminals N01 and N02.</p> <p>Examine the ribbon cable connections on the board.</p> <p>Removed and then apply power to the analyzer.</p> <p>Replace the O₂ Controller Board if necessary. Refer to Replacement parts and accessories on page 39.</p>
92_HI AIR PRESSURE 2	The air pressure supply was more than 2.0 bar for more than 5 seconds. When the oxygen concentrator is on, the air pressure supply is normally between 0.9 bar to 1.5 bar. If the air pressure does not decrease to normal values, the air supply is isolated from the analyzer and oxygen is not made.	<p>The external air regulator is not operating correctly.</p> <p>Decrease the external air supply pressure to 1.5 bar when the oxygen concentrator is not in operation.</p> <p>When the problem is fixed, acknowledge the warning to reset the O₂ Controller Board.</p>
93_HI AIR PRESSURE 1	The air pressure supply was more than 1.8 bar for more than 60 seconds. When the oxygen concentrator is on, the air pressure supply is normally between 0.9 bar to 1.5 bar.	<p>The external air regulator is not operating correctly.</p> <p>Stop the analyzer. Decrease the external air supply pressure to 1.5 bar when the oxygen concentrator is not in operation.</p> <p>When the problem is fixed, acknowledge the warning to reset the O₂ Controller Board.</p>
94_LO AIR PRESSURE 2	The air pressure supply was less than 0.6 bar for more than 5 seconds. When the oxygen concentrator is on, the air pressure supply is normally between 0.9 bar to 1.5 bar. If the air pressure does not increase to normal values, the air supply is isolated from the analyzer and oxygen is not made.	<p>The external air regulator is not operating correctly.</p> <p>Increase the external air supply pressure to 1.5 bar when the oxygen concentrator is not in operation.</p> <p>When the problem is fixed, acknowledge the warning to reset the O₂ Controller Board.</p>
95_LO AIR PRESSURE 1	The air pressure supply was less than 0.8 bar for more than 60 seconds. When the oxygen concentrator is on, the air pressure supply is normally between 0.9 bar to 1.5 bar.	<p>The external air regulator is not operating correctly.</p> <p>Stop the analyzer. Increase the external air supply pressure to 1.5 bar when the oxygen concentrator is not in operation.</p> <p>When the problem is fixed, acknowledge the warning to reset the O₂ Controller Board.</p>
96_HI O2 PRESSURE 2	The oxygen pressure supply was more than 500 mbar for more than 5 seconds. If the oxygen pressure does not decrease to normal values, the air supply is isolated from the analyzer and oxygen is not made.	<p>Select MAINTENANCE > DIAGNOSTICS > O2-CTRL STATUS. Use the oxygen pressure regulator to decrease the oxygen pressure to 400 mbar (±10 mbar) at 20 L/h MFC flow. When the problem is fixed, acknowledge the warning to reset the O₂ Controller Board.</p>
97_HI O2 PRESSURE 1	The oxygen pressure supply was more than 450 mbar for more than 60 seconds. If the oxygen pressure does not decrease to normal values, the air supply is isolated from the analyzer and oxygen is not made.	<p>Select MAINTENANCE > DIAGNOSTICS > O2-CTRL STATUS. Use the oxygen pressure regulator to decrease the oxygen pressure to 400 mbar (±10 mbar) at 20 L/h MFC flow.</p>

Table 3 System warnings (continued)

Message	Description	Cause and solution
98_LO O2 PRESSURE 2	The oxygen pressure supply was less than 150 mbar for more than 5 seconds. If the oxygen pressure does not increase to normal values, the air supply is isolated from the analyzer and oxygen is not made.	Select MAINTENANCE > DIAGNOSTICS > O2-CTRL STATUS. Use the oxygen pressure regulator to increase the oxygen pressure to 400 mbar (± 10 mbar) at 20 L/h MFC flow. When the problem is fixed, acknowledge the warning to reset the O ₂ Controller Board.
99_LO O2 PRESSURE 1	The oxygen pressure supply was less than 200 mbar for more than 60 seconds. If the oxygen pressure does not decrease to normal values, the air supply is isolated from the analyzer and oxygen is not made.	Select MAINTENANCE > DIAGNOSTICS > O2-CTRL STATUS. Use the oxygen pressure regulator to increase the oxygen pressure to 400 mbar (± 10 mbar) at 20 L/h MFC flow.
100_ROTARY V STOP:ON	The rotary valve stopped with the rotation sensor on (sensor signal 1). The sensor is not operating correctly because it always shows on (sensor signal 1).	Select MAINTENANCE > DIAGNOSTICS > SIMULATE > MFC. Set the MFC to 20 L/h. Examine the rotation of the rotary valve. Select MAINTENANCE > DIAGNOSTICS > O2-CTRL STATUS. Look at the rotary valve signals (1 = on, 0 = off) as the valve rotates.
101_ROTARY V STOP:OFF	The rotary valve stopped with the rotation sensor off (sensor signal 0). The sensor is not operating correctly because it always shows off (sensor signal 0).	Replace the rotary valve for the oxygen concentrator. Refer to Replacement parts and accessories on page 39. When the warning is gone, the green LED (Stepper) on the Oxygen PCB is on.
102_OZONE GEN FAULT	The current through the ozone generator decreased to less than 0.2 A for more than 5 seconds.	Examine Fuse 4 (F4) on the motherboard. Replace the fuse if blown. Refer to Replace a fuse on page 7. Make sure the fuse is fully in the fuse holder. Push the reset button on the motherboard. Remove power to the analyzer, wait 30 seconds, then apply power to the analyzer. Select MAINTENANCE > DIAGNOSTICS > SIMULATE > OZONE GENERATOR. Examine the ozone generator current, which should be between 0.35 A to 0.55 A.
103_OZONE FAN FAULT	The voltage on the ozone generator fan decreased to less than 1.5 V (or increased to more than 3.5 V) for more than 5 seconds. <i>Note: The ozone generator fan is an optional component.</i>	Examine the fan operation in the ozone generator. Examine the wiring on terminals N01 and N03 on the ozone generator board.
107_COOLER FAULT	The current through the cooler decreased to less than 0.1 A for more than 5 seconds.	Examine Fuse 3 (F3) on the motherboard. Replace the fuse if blown. Refer to Replace a fuse on page 7. Make sure the fuse is fully in the fuse holder. Examine the cooler wiring on the green terminal block. Examine the wiring between the cooler and the Termination Board (81204370_xx.). Select MAINTENANCE > DIAGNOSTICS > SIMULATE > COOLER. Set the cooler to 100%. Identify if the voltage on the peltier element of the cooler is 10 V. If not, use the cooler kit to replace the cooler fan and peltier element. Refer to Replacement parts and accessories on page 39.

Table 3 System warnings (continued)

Message	Description	Cause and solution
108_COOLER FAN FAULT	The monitoring voltage on the cooler fan decreased to less than 1.5 V (or increased to more than 3.5 V) for more than 5 seconds.	Examine the wiring between the cooler fan and the Termination Board (81204370_xx.) Measure the voltage on the cooler fan on the green terminal block. Identify if the voltage is 24 V. If not, use the cooler kit to replace the cooler fan. Refer to Replacement parts and accessories on page 39.
110_HI TEMP DUTYCYCLE	The analyzer temperature increased to more than 50 °C (122 °F) for more than 2 minutes. Note: <i>The analyzer added an analysis delay time of 300 seconds between each analysis cycle.</i>	Examine the filters in the fan and vent. Examine the operation of the fan. Make sure that the ambient temperature is less than 45 °C (113 °F) and the analyzer is not in direct sunlight. Note: <i>When the analyzer temperature is less than 48 °C (118 °F) for more than 2 minutes, the analyzer continues usual operation.</i>
111_HI TEMP STANDBY	The analyzer temperature increased to more than 55 °C (131 °F) for more than 2 minutes. The analyzer is in standby mode.	Examine the filters in the fan and vent. Examine the operation of the fan. Make sure that the ambient temperature is less than 45 °C (113 °F) and the analyzer is not in direct sunlight. Note: <i>When the analyzer temperature is less than 48 °C (118 °F) for more than 2 minutes, the analyzer continues usual operation.</i>
112_LO TEMP STANDBY	The analyzer temperature decreased to less than 2 °C (35 °F) for more than 2 minutes. The analyzer is in standby mode.	Make sure that the ambient temperature is 5 to 45 °C (41 to 113 °F). Note: <i>When the analyzer temperature is more than 5 °C (41 °F) for more than 2 minutes, the analyzer continues usual operation.</i>
113_TEMP SENSOR FAULT	The temperature difference between the MPU (micro processor unit) and analyzer temperature sensor is more than ±15 °C (±27 °F). Note: <i>The MPU temperature sensor is on the motherboard. The analyzer temperature sensor is on the O₂ Controller Board.</i>	Make sure that the motherboard cover is installed and the analyzer door is closed. Make sure that the ambient temperature is less than 45 °C (113 °F) and the analyzer is not in direct sunlight.
114_I/O WARNING	Changes in the Input/Output bus extender MCP23S17 chips were identified during the periodic checks done automatically. The Input/Output bus extender MCP23S17 chips have read/write control registers. Note: <i>The Input/Output bus extender MCP23S17 chips have read/write control registers.</i>	When the analyzer senses a difference between the requested and the read configuration registers values, all of the devices on the SPI (serial peripheral interface) bus are reset and re-initialized automatically. Select OPERATION > FAULT ARCHIVE. Acknowledge the warning and tell technical support.
115_CO2_ANALYZER_WARN	The operation of the CO ₂ analyzer is not correct.	Select MAINTENANCE > DIAGNOSTICS > SIMULATE. Examine the ppm CO ₂ response of the CO ₂ analyzer. Clean the lenses in the CO ₂ analyzer. Remove power to the analyzer, wait 30 seconds, then apply power to the analyzer. Examine the 24 V DC power to the CO ₂ analyzer on the motherboard at wires N11 and N12. For more tests, refer to the information sheet <i>T019, BioTector CO₂ Analyzer Troubleshooting</i> .

Table 3 System warnings (continued)

Message	Description	Cause and solution
128_REACT PURGE WARN	The gas flow is not normal. There is an instrument air or oxygen supply problem.	<ul style="list-style-type: none"> Blockage in the mixer reactor, reactor valve (MV3), sample valve (MV4) or associated tubing and fittings Blockage in the tube after MFC Failure of the MFC <p>Select MAINTENANCE > DIAGNOSTICS > O2-CTRL STATUS. The oxygen pressure is normally 400 mbar (±10 mbar) at 20 L/h MFC flow.</p> <p>Do a flow test. Refer to Do a flow test on page 23.</p>
135_MODBUS WARN	Internal Modbus tasks are in an unknown condition.	When this warning occurs, the Modbus circuit starts again automatically. Acknowledge the warning and tell the distributor or the manufacturer. If the warning continues, replace the motherboard. Refer to Replacement parts and accessories on page 39.

2.3 Notifications

Select OPERATION > FAULT ARCHIVE to see the notifications. When "SYSTEM NOTE" shows in the top-left corner of the Reaction Data screen or the Reagent Status screen, a notification has occurred. Refer to [Table 4](#).

Table 4 Notifications

Message	Description	Solution
85_LOW REAGENTS (can be set as a warning or note)	The calculated reagent levels identify that the reagent containers are at a low level.	Replace the reagents. Refer to Fill or replace the reagents on page 6. To increase the number of days before a LOW REAGENTS notification occurs, select MAINTENANCE > COMMISSIONING > REAGENTS MONITOR > LOW REAGENTS AT.
86_POWER UP	Power was supplied to the analyzer or a power reboot was done after the processor watchdog timeout.	This notification is automatically acknowledged. No action is necessary.
87_SERVICE TIME RESET	RESET SERVICE COUNTER was selected.	This notification is automatically acknowledged. No action is necessary.
122_SAMPLE FAULT 1 123_SAMPLE FAULT 2 124_SAMPLE FAULT 3	An external device sent a sample fault input signal to the analyzer.	Examine the external sample liquid level and sampling system for the sample channel. Examine the external sample monitoring device and the external input signal wiring.

2.4 Show the status history before a fault

Show a short status history of some analyzer components before a fault occurs. The default 0.0 value identifies that there are no faults for the component.

1. Select MAINTENANCE > SYSTEM CONFIGURATION > FAULT STATUS.
2. Select an option.

Option	Description
O2 FLOW	Shows 120 entries for the MFC (mass flow controller) setpoint value (first column) and MFC flow value (second column). The entries are at 1 second intervals. If a fault occurs, the entries are kept in the O2 FLOW fault archive until a new fault occurs.
CO2 ANALYZER FAULT	Shows 120 readings of the CO ₂ analyzer. The readings are at 2 second intervals (4 minutes total). If a fault occurs, the readings are kept in the CO2 ANALYZER FAULT archive until a new fault occurs.
BIOTECTOR TEMPERATURE	Shows 120 readings of the analyzer temperature. The readings are at 2 seconds intervals (4 minutes total). If a fault occurs, the readings are kept in the BIOTECTOR TEMPERATURE fault archive until a new fault occurs.
OZONE GEN FAULT	Shows 120 readings of the current through the ozone generator. If a fault occurs, the analyzer keeps the readings in the OZONE GEN FAULT archive until a new fault occurs. <i>Note: It is possible to identify between an abrupt fault and an intermittent fault using the fault data.</i>
COOLER FAULT	Shows 120 readings of the cooler. The entries are at 1 second intervals. The first column shows the current through the cooler in amperes. The second column shows percent output activation time of the cooler. For example, 90% means that the analyzer activates the cooler for 90% of the pulse width modulation period. If a fault occurs, the analyzer keeps the reading in the COOLER FAULT archive until a new fault occurs.

Section 3 Diagnostics

3.1 Do a pressure test

Do a pressure test to identify if there is a gas leak in the analyzer.

1. Select MAINTENANCE > DIAGNOSTICS > PROCESS TEST > PRESSURE TEST.
2. Select PRESSURE TEST, then push ✓.

A pressure test starts (60 seconds). The information that follows shows.

Item	Description
TIME	Shows the remaining time for the test.
MFC SETPOINT	Shows the mass flow controller (MFC) setting for the test (default: 40 L/hr).
MFC FLOW	Shows the flow from the MFC. If there is no gas leak, the flow will slowly decrease to near 0 L/hr after 25 seconds.
STATUS	Shows the results of the test. TESTING —Test in progress PASS —The flow from the MFC at the end of the test is less than 4 L/hr (default). WARNING —The flow from the MFC at the end of the test is more than 4 L/hr but less than 6 L/hr (default). FAIL —The flow from the MFC at the end of the test is more than 6 L/hr (default). <i>Note: To change the default limits for the test, select MAINTENANCE > SYSTEM CONFIGURATION > SEQUENCE PROGRAM > PRESSURE/FLOW TEST.</i>

3. If the pressure test fails, select PRESSURIZE REACTOR, then push ✓ to find the location of a leak. A longer test starts (999 seconds).

3.2 Do a flow test

Do a flow test to identify if there is blockage in the gas exhaust or the sample out lines.

1. Select MAINTENANCE > DIAGNOSTICS > PROCESS TEST > FLOW TEST.
2. Select EXHAUST TEST, then push ✓.

A flow test starts (30 seconds). The information that follows shows.

Item	Description
TIME	Shows the remaining time for the test.
MFC SETPOINT	Shows the mass flow controller (MFC) setting for the test (default: 60 L/hr).
MFC FLOW	Shows the flow from the MFC. If there is no blockage, the flow is approximately 60 L/hr.
STATUS	Shows the results of the test. TESTING —Test in progress PASS —The flow from the MFC at the end of the test is more than 45 L/hr (default). WARNING —The flow from the MFC at the end of the test is less than 45 L/hr but more than 40 L/hr (default). FAIL —The flow from the MFC at the end of the test is less than 30 L/hr (default). <i>Note: To change the default limits for the test, select MAINTENANCE > SYSTEM CONFIGURATION > SEQUENCE PROGRAM > PRESSURE/FLOW TEST.</i>

3. If the exhaust test fails, select EXHAUST FLOW, then push ✓ to find the location of the blockage (e.g., at the exhaust valve). A longer test starts (999 seconds).
4. Select SAMPLE OUT TEST, then push ✓.
A sample out test is started. The test identifies if there is a blockage sample out lines.
5. If the sample out test fails, select SAMPLE OUT FLOW, then push ✓ to find the location of the blockage (e.g., at the sample out valve). A longer test starts (999 seconds).

3.3 Do an ozone test

Do an ozone test to identify if the operation of the ozone generator is correct.

1. Install the ozone tester in the analyzer. Refer to information sheet *T029. Procedure to check the ozone level in a BioTector B3500 and B7000 using a universal ozone tester.*
2. Select MAINTENANCE > DIAGNOSTICS > PROCESS TEST > OZONE TEST.
3. Select START TEST.
The analyzer does a pressure test. Then the ozone generator is set to on. An ozone warning message shows on the display.
4. When the O-ring in the tester breaks, select STOP TEST.
The analyzer removes all of the ozone from the ozone tester (30 seconds). The test results show on the display.

Item	Description
TIME	Shows the time for the O-ring to break.
MFC SETPOINT	Shows the MFC setpoint (e.g., 40.0 L/h).
MFC FLOW	Shows the MFC flow (e.g., 20.0 L/h).
STATUS	Shows the results of the test. TESTING —Test in progress PASS —The time to break the O-ring was less than 18 seconds (default). LOW OZONE —The time to break the O-ring was more than 18 seconds but less than 60 seconds (default). FAIL —The time to break the O-ring was more than 60 seconds. <i>Note: To change the default limits for the test, select MAINTENANCE > SYSTEM CONFIGURATION > FAULT SETUP > OZONE TEST TIME.</i>

3.4 Do a sample pump test

Do a sample pump test to identify the correct forward and reverse times for the sample pump for each sample stream.

1. Select MAINTENANCE > DIAGNOSTICS > PROCESS TEST > SAMPLE PUMP TEST.
2. Select an option.

Option	Description
VALVE	Sets the SAMPLE or MANUAL valve used for the test. For example, to select the SAMPLE valve, select STREAM 1.

Option	Description
PUMP FORWARD TEST	<p>Starts the sample pump in the forward direction.</p> <p>Note: First select PUMP REVERSE TEST to empty the sample lines, then select PUMP FORWARD TEST.</p> <ol style="list-style-type: none"> 1. Push  to stop the timer when the sample comes out the SAMPLE OUT fitting on the left side of the analyzer. 2. Record the time on the display. Add 10 seconds to the time. The time is the correct forward time for the selected stream.
PUMP REVERSE TEST	Starts the sample pump in the reverse direction.
SAMPLE PUMP	Goes to the MAINTENANCE > COMMISSIONING > SAMPLE PUMP menu to set the forward and reverse times for each sample stream.

3.5 Do a pH test

⚠ CAUTION	
	Chemical exposure hazard. Obey laboratory safety procedures and wear all of the personal protective equipment appropriate to the chemicals that are handled. Refer to the current safety data sheets (MSDS/SDS) for safety protocols.
⚠ CAUTION	
	Chemical exposure hazard. Dispose of chemicals and wastes in accordance with local, regional and national regulations.

Do a pH test to identify if the pH of the solution in the reactor is correct at the different steps of a reaction.

Items to collect:

- pH paper
 - Glass beaker
 - Personal protective equipment (refer to MSDS/SDS)
1. Put on the personal protective equipment identified in the safety data sheet (MSDS/SDS).
 2. Select MAINTENANCE > DIAGNOSTICS > PROCESS TEST > pH TEST.
 3. Select RANGE, VALVE.
 4. Set the operation range (e.g., 1) and the stream (e.g., STREAM 1) to use for the test. Refer to the OPERATION > SYSTEM RANGE DATA screen to see the operation ranges. Select the operation range that agrees with normal measurements for the sample stream.
 5. Select MODE.
 6. Select the test mode (e.g., TIC+TOC).
 7. Select START TEST.
 8. Push  again to confirm that the previous reaction completed normally.

The analyzer does the items that follow in sequence:

 - A normal startup completes in approximately 210 seconds (ozone purge, reactor purge, pressure test and flow test).
 - Adds the sample and TIC acid to the reactor. Then the program pauses so the TIC pH can be measured by the user.

- Adds the base reagent to the solution in the reactor. Then the program pauses so the base pH can be measured by the user.
 - Adds the TOC acid to the solution in the reactor. Then the program pauses so the pH can be measured by the user.
 - The reactor and CO₂ analyzer purge phase is completed.
9. When "TEST TIC pH" shows on the display, select an option.

Option	Description
TAKE SAMPLE	<p>Sets the sample out valve to on for 0.1 seconds.</p> <p>Select TAKE SAMPLE. Disconnect the tube that connects the outlet tube of the reactor valve to the Y fitting. Tip the tube gently down to collect 3 drops of liquid. Measure the pH of the liquid with pH paper. The expected pH shows on the display.</p> <p>Note: The loss of volume in the reactor when a sample is collected can have a negative effect on the pH of the samples collected at the next step. For the best accuracy, collect only one sample during a pH test, then complete the test. Start the pH test again and collect a sample at a different step (e.g., TEST BASE pH).</p>
CONTINUE TO NEXT PHASE	The analyzer goes to the next step of the program.
STOP TEST	The analyzer goes to the last step of the program, reactor purge.

10. When "TEST BASE pH" shows on the display, select an option. The options are the same as for the previous step.
11. When "TEST TOC pH" shows on the display, select an option. The options are the same as for the previous step.
12. When "CONFIRM ALL TUBES RE-CONNECTED" shows, push ✓ to confirm. The reactor and CO₂ analyzer purge phase is done.

3.6 Do simulations

Do simulations to identify if a component (e.g., pumps, valves and mass flow controller) operation is correct.

Note: Each time a component is activated, the analyzer will stop the operation of other devices as necessary to prevent damage to the analyzer.

When the back key is pushed to exit the menu, the analyzer does a pump synchronization process.

1. Select MAINTENANCE > DIAGNOSTICS > SIMULATE.

The status of the analyzer components show.

2. Select an option.

When a component is on, an asterisk (*) shows before the component name on the display.

Note: Changes made to settings in this menu are not saved.

Option	Description
MFC	<p>Sets the mass flow controller (MFC) flow (e.g., 40 L/h). Set the flow. Push ✓ to start the mass flow controller (MFC). The measured flow shows at the top of the display.</p> <p>Note: If the flow shown is 0.0 L/h, the MFC is off.</p>
OZONE GENERATOR	<p>Sets the ozone generator to on or off.</p> <p>Note: For safety, before the ozone generator is set to on, a pressure test is done. If a gas leak is found, the ozone generator is not set to on.</p>

Option	Description
OZONE GENERATOR FAN	Shows the status (on or off) and voltage at the ozone generator fan. When the fan is on, the voltage shown is usually 2.5 V.
ACID PUMP	Sets the acid pump to on or off. Sets the number of pulses. When the pump is in operation, the actual pulse time (external brackets) and the set pulse time (internal brackets) show.
BASE PUMP	Sets the base pump to on or off. Sets the number of pulses. When the pump is in operation, the actual pulse time (external brackets) and the set pulse time (internal brackets) show.
SAMPLE PUMP	Sets the sample pump to the selected operation mode. Options: FWD (forward), REV (reverse), P-FWD (pulse control forward) or P-REV (pulse control reverse). If P-FWD or P-REV is selected, set the number of pulses ($\frac{1}{2}$ revolution of the pump roller). When the pump is in operation, the actual pulse time (external brackets) and the set pulse time (internal brackets) show.
REACTOR MOTOR	Sets the mixer reactor motor to on or off.
SAMPLE VALVE	Sets the sample (out) valve, MV4, to on or off.
REACTOR VALVE	Sets the reactor valve to on or off.
EXHAUST VALVE	Sets the exhaust valve to on or off.
CALIBRATION VALVE (optional)	Sets the calibration/manual valve (MV5) to on or off.
STREAM VALVE	Sets a sample stream valve to on or off. Select the number of the stream valve. Only one stream valve can be set to on at one time.
MANUAL VALVE	Sets a manual valve to on or off. Select the manual valve. Only one manual valve can be set to on at one time.
COOLER	Sets the cooler to on, off or automatic to identify if the cooler relay operation is correct. The current through the cooler shows, which is usually 1.00 to 1.5 A.
COOLER FAN	Shows the status (on or off) and voltage at the cooler fan. When the fan is on, the voltage shown is usually 2.5 V.
LEAK DETECTOR	The LEAK DETECTOR option cannot be selected. The condition of the Liquid Leak Detector alarm input shows on the display.
SYSTEM FAN	Sets the fan to on, off or automatic to identify if the fan relay operation is correct. The analyzer temperature shows on the display. When FAN is set to AUTO, the analyzer sets the fan to off when the analyzer temperature is less than 25 °C. The fan operates continuously when the analyzer temperature is more than 25 °C.
TEMP SWITCH	Sets the temperature switch to on, off or automatic to identify if the temperature switch operation is correct. When TEMP SWITCH is set to AUTO, the analyzer sets the temperature switch to on when the analyzer temperature is 20 °C (default) or higher. The temperature switch stays on until the analyzer temperature is less than 20 °C.
SAMPLER FILL	Sets the signal to fill the sampler to on or off. The signal stays on until set to off.
SAMPLER EMPTY	Sets the signal to make the sampler empty to on or off. The signal stays on for 5 seconds.

Option	Description
SAMPLER ERROR	Sets the signal for a sampler error to on or off. The sampler error signal is normally sent from the sampler when there is an error in the sampler.
SAMPLE SENSOR	The SAMPLE SENSOR option cannot be selected. The condition of the sample sensor shows on the display.
REACTOR PURGE	Starts the reactor purge operation.
RUN REAGENTS PURGE	Starts the reagent prime operation, which fills the reagent tubing with reagent.
INPUT/OUTPUT STATUS	Goes to the MAINTENANCE > DIAGNOSTICS > INPUT/OUTPUT STATUS menu. The INPUT/OUTPUT STATUS menu shows the conditions of the digital inputs, digital outputs, analog inputs and analog outputs.

3.7 Do a relay or 4–20 mA output test

Do a signal simulation to identify if the relay and 4–20 mA output operation is correct.

1. Select MAINTENANCE > DIAGNOSTICS > SIGNAL SIMULATE.
2. Select an option.

Option	Description
ALARM 1 to 3	Sets the ALARM relay to on if configured.
CHANNEL 1 to 3	Sets a 4–20 mA output (e.g., CHANNEL 1) to a selected 4–20 mA signal.
CO2 ALARM 1 to 3	Sets the CO2 ALARM relay to on if configured.
SAMPLE FAULT 1 to 3	Sets the SAMPLE FAULT relay to on for a specified stream if configured.
SYNC RELAY	Sets the SYNC relay to on if configured.
SAMPLE STATUS 1 to 3	Sets the SAMPLE STATUS relay to on for a specified stream if configured.
CAL SIGNAL	Sets the CAL SIGNAL relay to on if configured.
MAINT SIGNAL	Sets the MAINT SIGNAL relay to on if configured.
REMOTE STANDBY	Sets the REMOTE STANDBY relay to on if configured.
STOP	Sets the STOP relay to on if configured.
FAULT	Sets the FAULT relay to on if configured.
WARNING	Sets the WARNING relay to on if configured.
NOTE	Sets the NOTE relay to on if configured.
MAN MODE TRIG	Sets the MAN MODE TRIG relay to on if configured.
4-20mA CHNG	Sets the 4-20mA CHNG relay to on if configured.
4-20mA CHNG 1 to 3	Sets a 4-20mA CHNG1 to 3 relay to on for a specified stream if configured.
4-20mA READ	Sets the 4-20mA READ relay to on if configured.

Option	Description
DW FAIL	Sets the DW FAIL (drinking water percent removal fail) relay to on if configured.
INPUT/OUTPUT STATUS	Goes to the MAINTENANCE > DIAGNOSTICS > INPUT/OUTPUT STATUS menu. The INPUT/OUTPUT STATUS menu shows the conditions of the digital inputs, digital outputs, analog inputs and analog outputs.

3.8 Show the input and output status

Show the signals at the digital inputs, digital outputs, analog inputs and analog outputs to examine their operation.

1. Select MAINTENANCE > DIAGNOSTICS > INPUT/OUTPUT STATUS.
2. Select an option.

Option	Description
DIGITAL INPUT	Shows the digital signal at the digital inputs (1 = active, 0 = not active). "DI" followed by two digits identifies the digital inputs. For example, DI09 is Digital Input 9. The digital input number is followed by the digital signal at the input and then the function. "[PROGRAMMABLE]" identifies the configurable digital inputs. Note: DI06 is the enter key. Push and hold down the enter key to change the digital signal at DI06 to 1.
DIGITAL OUTPUT	Shows the digital signal at the digital outputs (1 = active, 0 = not active). "DO" followed by two digits identifies the digital outputs. For example, DO21 is Digital Output 21. The digital output number is followed by the digital signal at the output and then the function. "[PROGRAMMABLE]" identifies the configurable digital outputs. Note: When the analyzer is set to on, all of the digital outputs are set to 0. Note: DO34 has a digital signal of 1 when the ozone destructor heater for the ozone destructor is on and 0 when the ozone destructor heater is off.
ANALOG INPUT	Shows the ADC converter digital value, input voltage and function of each analog input. The analyzer uses a 12-bit ADC, so the range of the digital value is 0 to 4095. The input voltage range is 0 to 5.00 V. Note: PWR BRD IN1 is the analog input signal (AI-1) at terminals 51 and 52 on the Power and Input/Output Board. PWR BRD IN2 is the analog input signal (AI-2) at terminals 53 and 54.
ANALOG OUTPUT	Shows the DAC converter digital value, output voltage and function of each analog output. The analyzer uses a 12-bit DAC, so the range of the digital value is 0 to 4095. The output voltage range is 0 to 10.00 V.

3.9 Show the oxygen controller status

Show the system air supply, oxygen supply, gas flow, pressure and temperature parameters.

1. Select MAINTENANCE > DIAGNOSTICS.
2. Select O2-CTRL STATUS.

The oxygen concentrator is set to on. The information that follows shows on the display:

- **IDENTIFICATION** —The identification number for the oxygen controller board.
- **VERSION** —The software version of the oxygen controller board.

- **MODE** —Sets the mode of the oxygen controller board. The modes follow:
MFC: The oxygen controller board operates the mass flow controller.
O2: The oxygen controller board operates the oxygen concentrator.
MFC AND O2: The oxygen controller board operates the MFC and oxygen concentrator.
- **TEMPERATURE SENSOR** —The first value is the temperature of the analyzer at the oxygen controller board. The second value is the voltage reading from the temperature sensor.
- **AIR PRESS SENSOR** —The first value is the air inlet pressure for the oxygen concentrator. The second value is the voltage reading from the air pressure sensor.
- **O2 PRESS SENSOR** — The first value is the oxygen inlet pressure for the MFC (normally 400 mbar (± 10 mbar) at 20 L/h MFC setpoint. The second value is the voltage reading from the oxygen pressure sensor.
- **VALVE1, 2, 3**—The oxygen controller valve outputs for Valves 1, 2 and 3 (1 = on, 0 = off). Valve 1 is the air isolation valve. Valve 2 and 3 are reserved.
- **ROTARY VALVE** —The operation of the rotary valve (FORWARD, REVERSE or STOP).
Note: Approximately September 2022, the rotary valve was removed from the analyzer.
- **ROTARY VALVE SENSOR** —The sensor position of the rotary valve (1 = rotary valve is on the sensor, 0 = the valve is not on the sensor).
Note: Approximately September 2022, the rotary valve sensor was removed from the analyzer.
- **MFC SETPOINT** —Sets the setpoint for the mass flow controller. Push enter (checkmark icon), select the setpoint, then push enter again. The MFC flow shows at the top of the display. The MFC is off when the flow is 0.0 L/h.
- **MFC FLOW** —The first value is the MFC flow. The second value is the voltage reading from the MFC. When the analyzer is stopped or in remote standby, the MFC setpoint is 1 L/h.

3.10 Show the Modbus status

1. Select MAINTENANCE > DIAGNOSTICS > MODBUS STATUS.
2. Select an option.

Option	Description
MODE	Shows the Modbus operating mode, which is BIOTECTOR.
DEVICE BUS ADDRESS	Shows the Modbus address of the instrument.
BUS MESSAGE COUNT	Shows the number of Modbus messages that were correctly received and were sent to the Modbus address of the instrument. <i>Note: When the count is 65,535, the subsequent message received sets the count to 1.</i>
BUS COM ERROR COUNT	Shows the number of corrupted or not fully received Modbus messages that the Modbus received. <i>Note: When the count is 65,535, the subsequent message received sets the count to 1.</i>
MANUFACTURE ID	Shows the manufacturer ID for the instrument (e.g., 1 for Hach).
DEVICE ID	Shows the class or family of the instrument, if entered (default: 1234).
SERIAL NUMBER	Shows the serial number of the instrument.
LOCATION TAG	Shows the location of the instrument.

Option	Description
FIRMWARE REV	Shows the firmware revision installed on the instrument.
REGISTERS MAP REV	Shows the Modbus register map version used by the instrument. Refer to the Modbus register maps in the Advanced Configuration Manual.

After the menu options, the first 17 bytes of the last received (RX) and transmitted (TX) Modbus message show.

3.11 Modbus troubleshooting

1. Make sure that the device bus address is correct. Refer to the *Configure the Modbus settings* in the Installation and Operations Manual.
2. Make sure that the register address (5-digit code) is correct.
3. Select MAINTENANCE > DIAGNOSTICS > MODBUS STATUS > BUS COM ERROR COUNT. Look at the bus transmission error count.
The bus error count should increase each time the analyzer reads an invalid or not fully received Modbus message.
Note: *Valid messages that are not addressed to the instrument do not increase the counter.*
4. For the Modbus RTU option, make sure that the wire connected to terminal D+ is positively biased compared to the wire connected to terminal D– when the bus is in an idle condition.
5. Make sure that there is a jumper installed on J15 of the motherboard at the end of the bus to terminate the bus. The motherboard is in the electronic enclosure on the door behind the stainless steel cover.
6. For the Modbus TCP option, open the web interface. Refer to *Configure the Modbus TCP/IP module* in the Installation and Operation Manual. If the web interface does not open, do the steps that follow:
 - a. Make sure that the network settings are correct.
 - b. Make sure that the Ethernet cable connectors are fully installed in the Ethernet ports.
 - c. Make sure that the LED for the Modbus TCP/IP (RJ45) connector is green.

Section 4 Analysis enclosure

[Figure 6](#) shows the interior view of the analyzer.

[Figure 7](#) shows how to open the inner door.

Approximately September 2022, the oxygen concentrator parts changed.

[Figure 8](#) shows the internal view with the inner door open after the change.

[Figure 9](#) shows the internal view with the inner door open before the change.

Analysis enclosure

Figure 6 Internal view

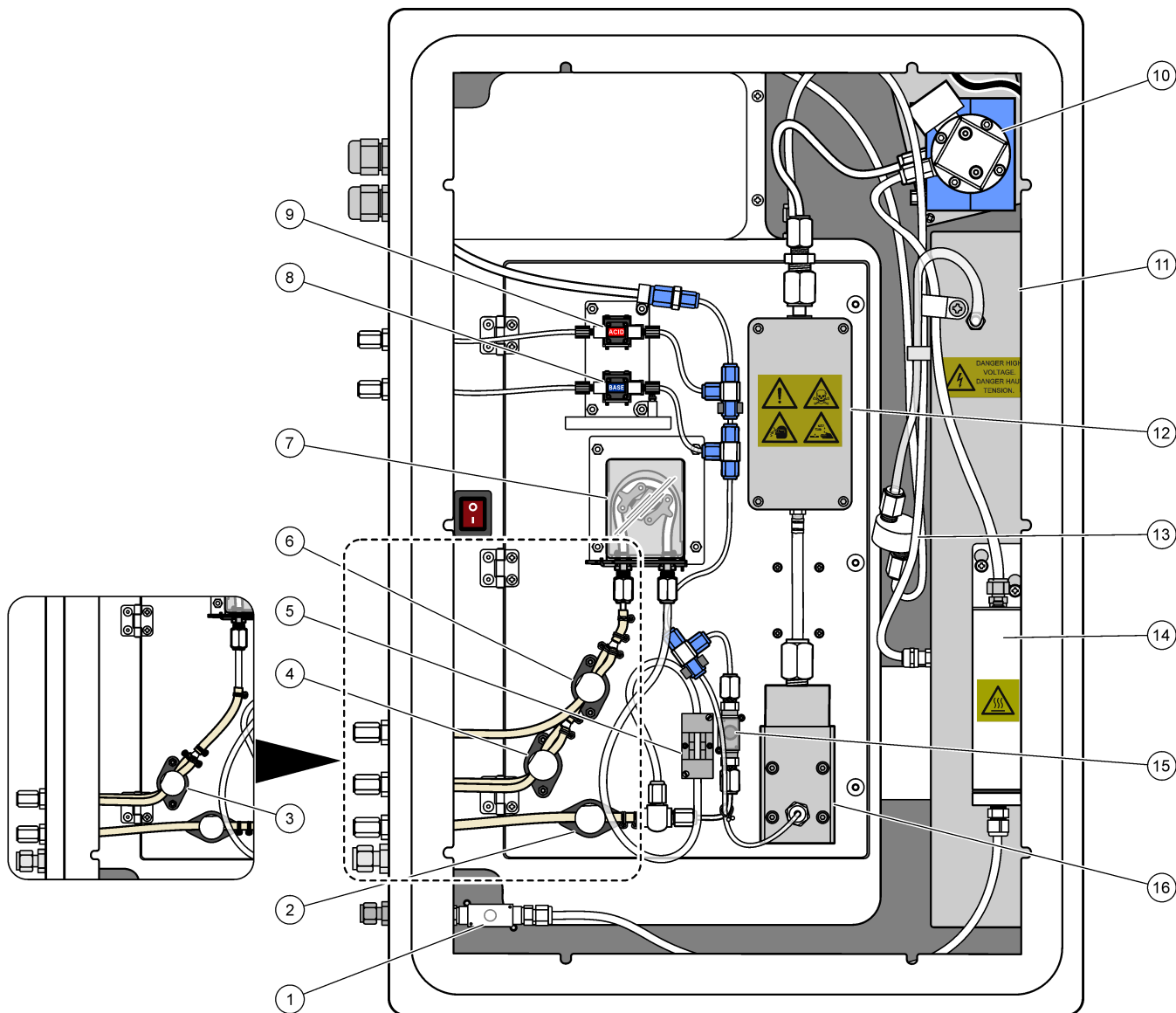

1 Exhaust valve, MV1	9 Acid pump, P3
2 Sample (out) valve, MV4	10 NDIR CO ₂ analyzer
3 Sample and Manual valve, MV5 ²	11 Ozone generator
4 Sample 1 and Sample 2 valve, MV6 ³	12 Cooler
5 Sample sensor	13 Ozone line filter
6 Manual valve, MV5 ³	14 Ozone destructor
7 Sample pump, P1	15 Reactor valve, MV3
8 Base pump, P4	16 Mixer reactor

² Single-stream analyzers (one exterior sample fitting)

³ Dual-stream analyzers (two exterior sample fittings)

Figure 7 Open the inner door

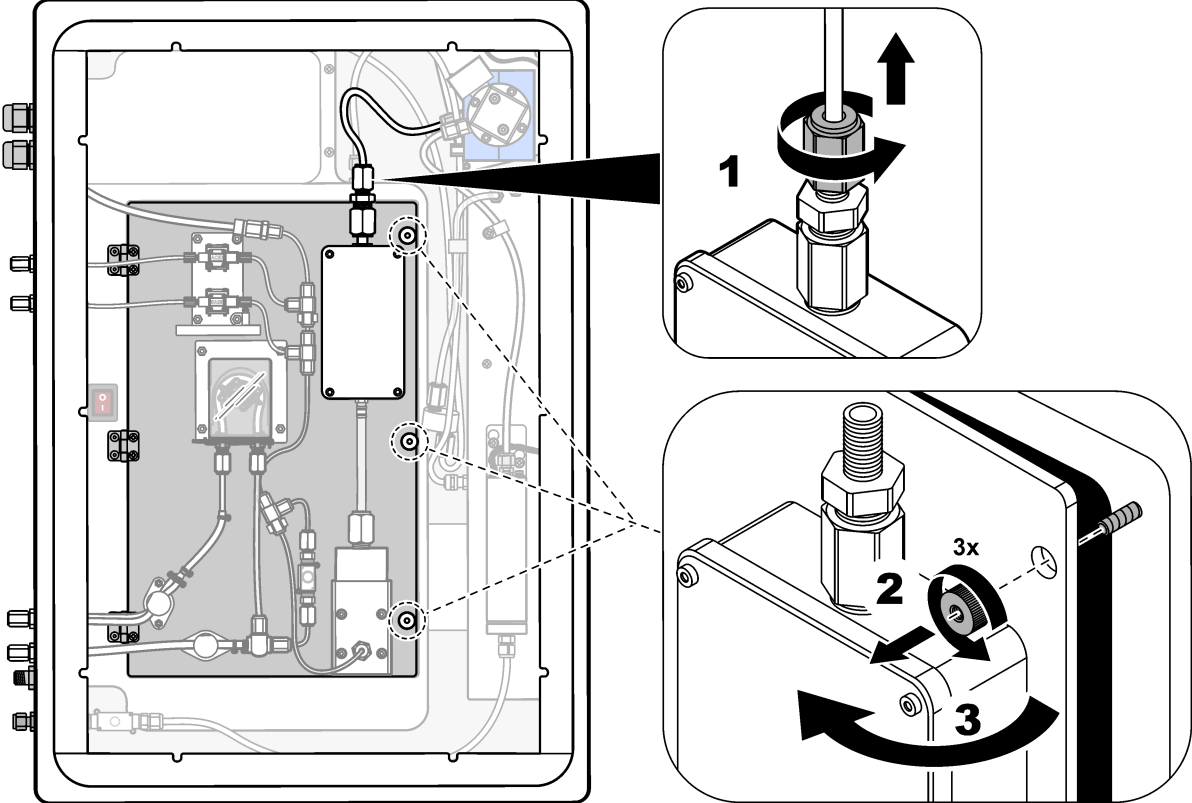

Analysis enclosure

Figure 8 Internal view—Inner door open

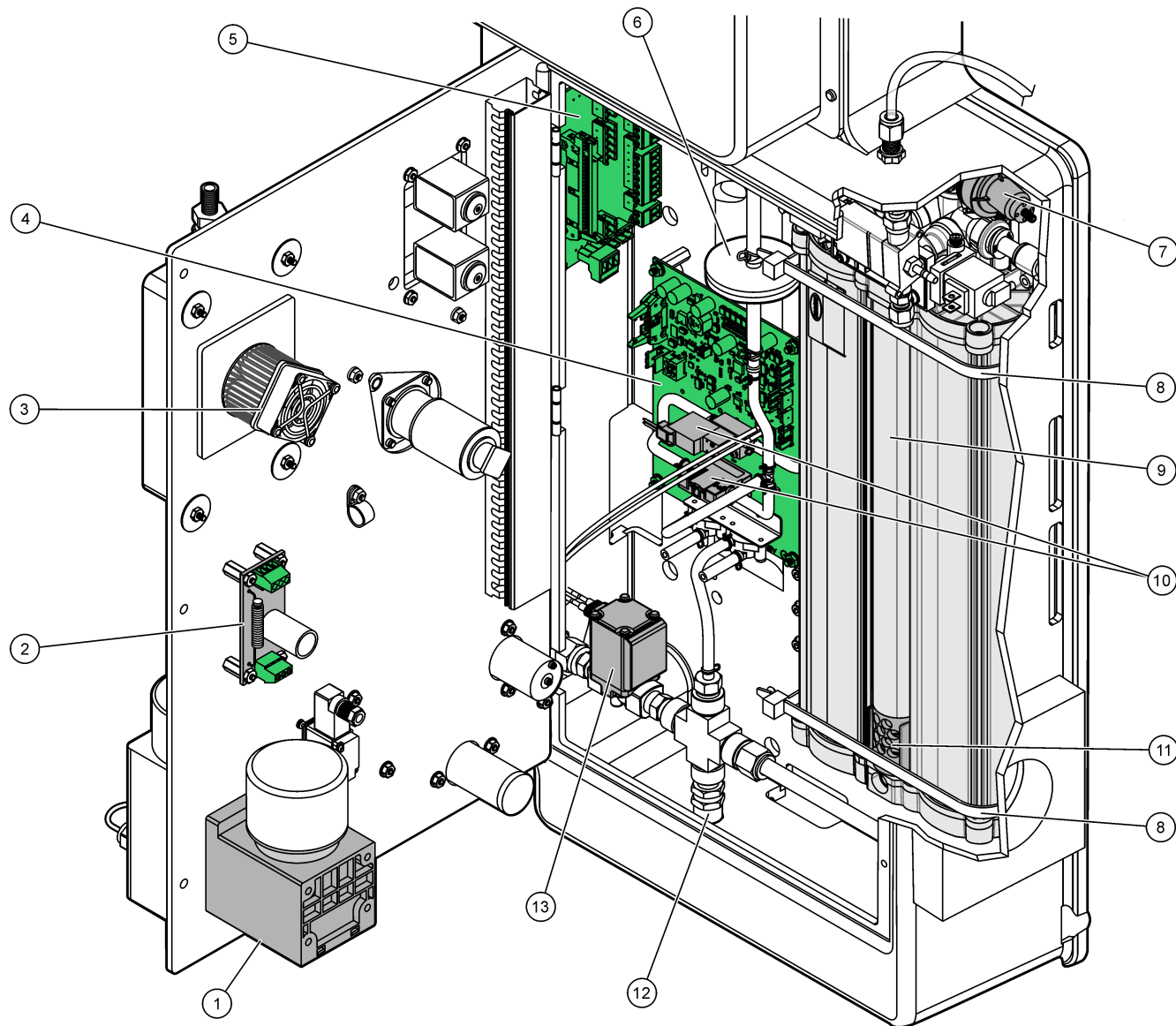

1 Mixer reactor motor, P2	8 Cable tie (2x)
2 Filter Board	9 Oxygen concentrator
3 Cooler fan	10 Mass flow controller (MFC)
4 Oxygen Control Board	11 Exhaust filter
5 Termination Board	12 Pressure relief valve
6 HEPA filter	13 Air isolation valve, OV1
7 Oxygen pressure regulator	

Figure 9 Internal view—Inner door open (before September 2022)

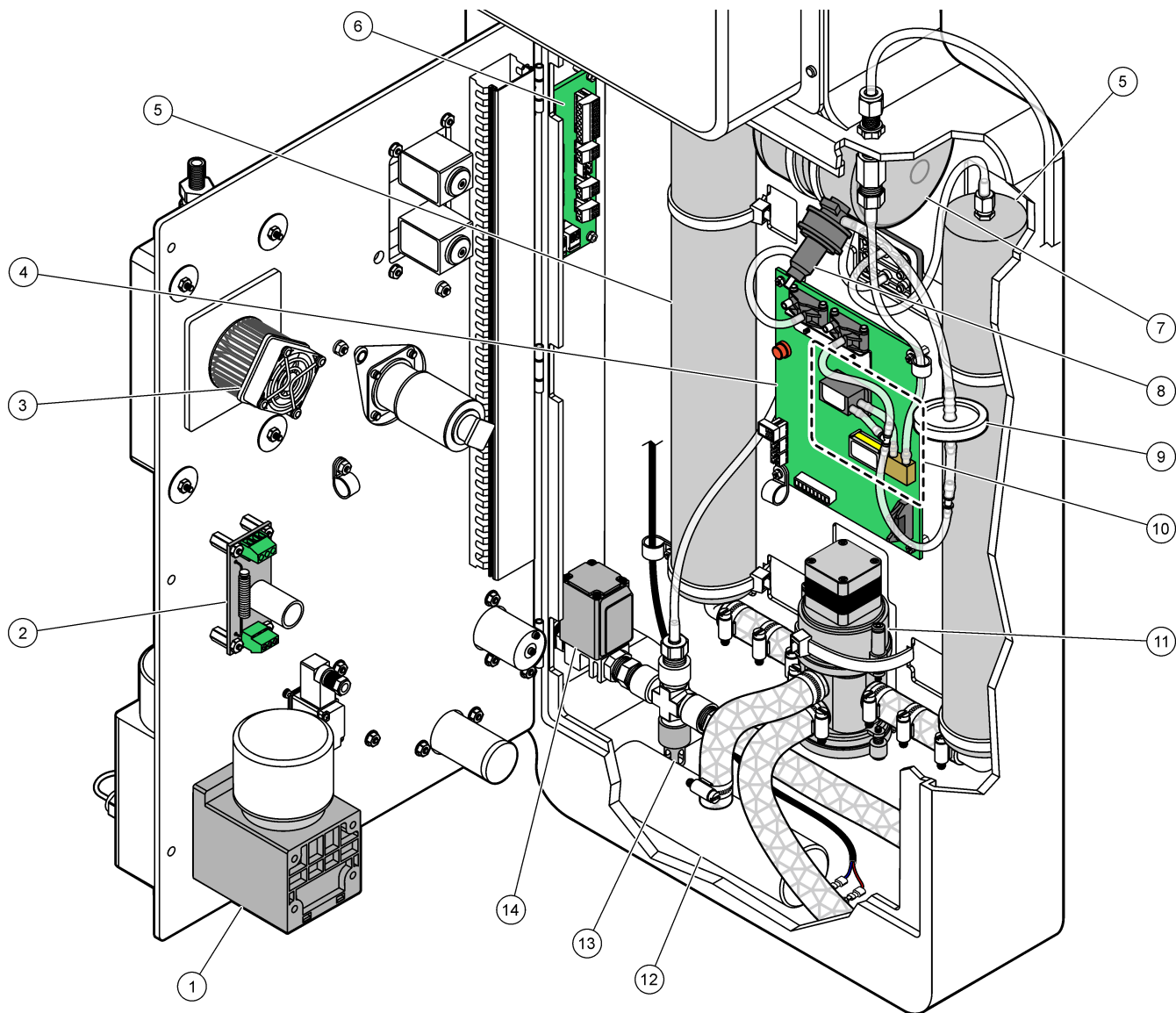

1 Mixer reactor motor, P2	8 Oxygen pressure regulator
2 Filter Board	9 HEPA filter
3 Cooler fan	10 Mass flow controller (MFC)
4 Oxygen Control Board	11 Oxygen concentrator rotary valve, OV2
5 Molecular sieve beds for oxygen concentrator	12 Exhaust filter
6 Termination Board	13 Pressure relief valve
7 Oxygen tank	14 Air isolation valve, OV1

Section 5 Replacement parts and accessories

⚠ WARNING



Personal injury hazard. Use of non-approved parts may cause personal injury, damage to the instrument or equipment malfunction. The replacement parts in this section are approved by the manufacturer.

Note: Product and Article numbers may vary for some selling regions. Contact the appropriate distributor or refer to the company website for contact information.

Consumables

Description	Quantity	Item no.
Acid reagent, 6.0 N Sulfuric Acid containing 350-mg/L Manganese Sulfate Monohydrate	20 L (5.2 gallons)	2038162
Base reagent, 4.0 N Sodium Hydroxide	20 L (5.2 gallons)	2038062
Deionized water	4 L (1 gallon)	27256
TOC standard, 1.0 mg/L	1 L	8886200
TOC standard, 2.0 mg/L	4 L	5846200
TOC standard, 5.0 mg/L	1 L	8886300
TOC standard, 5.0 mg/L	4 L	5847100
TOC standard, 10.0 mg/L	4 L	5846700
TOC standard, 25.0 mg/L	4 L	5846300

Oxygen concentrator replacement parts

Refer to [Figure 9](#) on page 37 to identify the oxygen concentrator parts.

Description	Quantity to stock	Item no.
Oxygen concentrator, molecular sieve beds (2)	1	12-DVB-013
Oxygen concentrator, pressure relief valve	0	10-DVB-024
Oxygen concentrator, pressure regulator	0	10-DVB-012
Oxygen concentrator, rotary valve	1	20-B5C-011

Replacement parts

Description ⁴	Quantity to stock	Item no.
6-month maintenance kit, B3500c/s, B3500dw and B3500ul TOC analyzer	2	19-KIT-123
Air isolation valve, N/C	0	19-B5C-012
CO ₂ analyzer, Hastelloy, 0–10000 ppm	0	20-CO2-008
Cooler kit with peltier element and fan	1	19-B5C-026
Dip tube (cap), acid reagent, with reagent filter	0	19-BS5-001
Dip tube (cap), base reagent, with reagent filter		19-BS5-002
Fan	0	19-B5C-022

⁴ Consumables/wearing parts: EMPP tubing, Y tube fittings, filters for the fan and vent, FPM/FKM tubing in the ozone generator, catalyst in the ozone destructor, CO₂ filter for the base reagent container, reactor valve, exhaust valve, diaphragm in the mixer reactor and 50 µm filters used in the acid and base reagent containers.

Replacement parts and accessories

Replacement parts (continued)

Description ⁴	Quantity to stock	Item no.
Filter pack elements for air supply	1 ⁵	12-SMC-001
Instrument air filter pack	0	10-SMC-001
Mixer reactor motor, 24 VDC	1	19-B5C-024
Mixer reactor, 316 stainless steel	0	19-B5C-009
Mixer reactor, 316 stainless steel, with 24 VDC motor	0	19-B5C-023
Motherboard with ARM core, includes: processor, LCD and ribbon cable	0	19-PCB-055
Oxygen (O ₂) controller board, B5C, complete	0	20-PCB-036
Ozone Board with terminal plugs	0	19-PCB-034
Ozone destructor	0	19-B5C-007
Ozone destructor heater	0	10-HAW-001
Ozone generator module, complete	0	20-B5C-025
PSU module, includes: Power and Input/Output Board	0	20-B5C-014
PTFE diaphragm for mixer reactor	1	10-KNF-038
PTFE ferrule and PEEK locking ring set, 1 x 3/16-in.	5	10-EMT-136
PTFE ferrule and PEEK locking ring set, 1 x 1/4-in.	5	10-EMT-114
PTFE ferrule and PEEK locking ring set, 1 x 1/8-in.	5	10-EMT-118
Pump, acid, FMM20	1	20-B5C-019
Pump, base, FMM20	1	20-B5C-020
Pump, sample, WMM60, B5C	1 ⁵	19-MAX-008
Reagent filter for dip tube	0	19-B5C-021
T fitting, PFA	1	10-IVF-118
Termination Board	0	20-PCB-038
Tubing, PFA, 1/4-in. OD x 4 mm ID, 1 m length	5 m length	10-SCA-003
Tubing, PFA, 1/8-in. OD x 1/16-inch ID, 1 m length	2 m length	10-SCA-001
Tubing, PFA, 3/16-in. OD x 1/8-inch ID, 1 m length	1 m length	10-SCA-002
Tubing, PFA, 1/4-in. OD x 1/8-in. ID (6.35-mm OD x 3.18-mm ID), 1 m length	5 m length	10-SCA-006
Tubing, EMPP 562, 6.4 mm OD x 3.2 mm ID, 1 m length	2 m length	10-REH-002
Valve, N/O, Type 6606 Burkert (exhaust valve, MV1)	1	19-B5C-014
Valve, N/C, Type 6606 Burkert (reactor valve, MV3)	1	19-B5C-015
Valve, pinch, N/O	1	19-B5C-016
Valve, pinch, C/O	1	19-B5C-017

⁴ Consumables/wearing parts: EMPP tubing, Y tube fittings, filters for the fan and vent, FPM/FKM tubing in the ozone generator, catalyst in the ozone destructor, CO₂ filter for the base reagent container, reactor valve, exhaust valve, diaphragm in the mixer reactor and 50 µm filters used in the acid and base reagent containers.

⁵ Normally replaced at 24 month intervals.

HACH COMPANY World Headquarters

P.O. Box 389, Loveland, CO 80539-0389 U.S.A.
Tel. (970) 669-3050
(800) 227-4224 (U.S.A. only)
Fax (970) 669-2932
orders@hach.com
www.hach.com

HACH LANGE GMBH

Willstätterstraße 11
D-40549 Düsseldorf, Germany
Tel. +49 (0) 2 11 52 88-320
Fax +49 (0) 2 11 52 88-210
info-de@hach.com
www.de.hach.com

HACH LANGE Sàrl

6, route de Compois
1222 Vézenaz
SWITZERLAND
Tel. +41 22 594 6400
Fax +41 22 594 6499

