

OPERATING INSTRUCTION MANUAL

Model 3444-series High Temperature/Pressure Style Contacting Conductivity/Resistivity Sensors

(Enhanced Performance Design)

Worldwide Sales:
GLI International, Inc.
9020 West Dean Road
Milwaukee, Wisconsin 53224, U.S.A.
phone: [414] 355-3601
fax: [414] 355-8346
e-mail: info@gliint.com

European Sales:
GLI International Ltd
Eastman Way, Hemel Hempstead
Hertfordshire. HP2 7HB England
phone: 01442 229310
fax: 01442 229311
e-mail: gli@gli.co.uk

In the interest of improving and updating its equipment, GLI reserves the right to alter specifications to equipment at any time.
A Member of the Environmental Instrumentation Group

HELPFUL IDENTIFIERS

In addition to information on installation and operation, this instruction manual may contain WARNINGS pertaining to user safety, CAUTIONS regarding possible sensor malfunction, and NOTES on important, useful operating guidelines.

A WARNING LOOKS LIKE THIS. ITS PURPOSE IS TO WARN THE USER OF THIS SENSOR OF THE POTENTIAL FOR PERSONAL INJURY.

A CAUTION LOOKS LIKE THIS. ITS PURPOSE IS TO ALERT THE USER OF THIS SENSOR TO POSSIBLE MALFUNCTION OR DAMAGE.

 **NOTE:** *A note looks like this. Its purpose is to alert the user of this sensor to important operating information.*

TABLE OF CONTENTS

PART ONE - INTRODUCTION

SECTION 1	GENERAL INFORMATION	
	1.1 Description:	
	Benefits of Enhanced Performance Design	5
	Sensor Characteristics.....	5
	1.2 Operating Precautions	5
SECTION 2	SPECIFICATIONS.....	6

PART TWO - INSTALLATION

SECTION 1	LOCATION REQUIREMENTS	7
SECTION 2	MOUNTING	
	2.1 Into Vessel Wall Using a Weldolet.....	8
	2.2 Into Pipe Using a Tee.....	8-9
SECTION 3	SENSOR/INTERCONNECT CABLE DETAILS	
	3.1 Sensor Cable Details	9
	3.2 Interconnect Cable Details	9-11
	3.3 Connecting Interconnect Cable.....	11

PART THREE - SERVICE AND MAINTENANCE

SECTION 1	RECOMMENDED CLEANING PROCEDURE	12
SECTION 2	TROUBLESHOOTING	
	2.1 Checking Sensor Operation	13
	2.2 Customer Assistance	14

ILLUSTRATIONS

Figure 2-1	General Dimensions and Cable Wire Details.....	7
Figure 2-2	Installing Sensor Into Vessel Wall Using a Weldolet	8
Figure 2-3	Installing Sensor Into Pipe Using a Tee	9
Figure 2-4	Interconnect Cable Termination Details	10

TABLES

Table A	Sensor Operational (Resistance) Checks	13
----------------	--	----

SENSOR WARRANTY/REPLACEMENT PLAN

GLI International, Inc. will replace or repair any sensor which fails due to defects in material or workmanship for a period of 1 year (12 months) from the date of shipment of this product from our facility. A warranty claim will not be honored if defects are not reported within the warranty period, or if GLI International determines that defects or damages are due to normal wear, misapplication, lack of maintenance, abuse, improper installation, alteration, or abnormal conditions. GLI International's obligation under this warranty shall be limited to, at its option, replacement or repair of this product. The product must be returned to GLI International, freight prepaid, for examination. The product must be thoroughly cleaned and any process chemicals removed before it will be accepted for replacement or repair. GLI International's liability shall not exceed the cost of the product. Under no circumstances will GLI International be liable for any incidental or consequential damages, whether to person or property. GLI International will not be liable for any other loss, damage or expense of any kind, including loss of profits, resulting from the installation, use, or inability to use this product.

PART ONE - INTRODUCTION

SECTION 1

GENERAL INFORMATION

1.1 Description

Benefits of Enhanced
Performance Design

Model 3444-series high temperature/high pressure style sensors are manufactured to exacting tolerances using high quality, rugged materials for demanding boiler and condensate measuring applications, and for high temperature process measurements. Each sensor is:

- Individually tested to determine its absolute cell constant (shown on its label as $K =$), and its temperature element value (to the nearest 1.0 ohm). Entering each sensor's GLI-certified "K" value and temperature "T" factor during instrument configuration or calibration, ensures the highest possible measurement accuracy.
- Built with a Pt 1000 RTD temperature element located at its tip to provide exceptionally fast response to changes in temperature with high measuring accuracy ($\pm 0.2^{\circ}\text{C}$).

Sensor
Characteristics

Model 3444-series high temperature/high pressure style sensors can be provided in a variety of ways:

Basic Cell Constant: 0.5 or 5.0.

Installation Style: 316 stainless steel body has 3/4-inch male NPT threads which can be threaded directly into a boiler wall, or insertion mounted into a pipe tee.

Termination Style: An integral 20 ft. (6 m) long cable or an integrally-mounted junction box (polypropylene, aluminum, or 316 stainless steel) with 3/4 inch female conduit connection.

1.2 Operating Precautions

Always consider the temperature/pressure ratings of the mounting hardware used to install the sensor. The sensor and hardware combine to become an integrated system. The hardware material usually limits the system's temperature/pressure rating. Refer to Section 2 for complete specifications.

<h2 style="margin: 0;">SECTION 2</h2>
<h3 style="margin: 0;">SPECIFICATIONS</h3>

Wetted Materials	316 stainless steel and titanium electrodes, PEEK insulator, and fluoroelastomer O-ring seals
Maximum Temperature	Sensor w/Integral Cord Grip: 212°F at 300 psi (100°C at 20.7 bar) Sensor w/Integral Polypropylene J-box Head: 198°F at 300 psi (92°C at 20.7 bar) Sensor w/Integral Aluminum or 316 SS J-box Head: 392°F at 300 psi (200°C at 20.7 bar)
Maximum Pressure	Sensor w/Integral Cord Grip: 300 psi at 212°F (20.7 bar at 100°C) Sensor w/Integral Polypropylene J-box Head: 300 psi at 198°F (20.7 bar at 92°C) Sensor w/Integral Aluminum or 316 SS J-box Head: 300 psi at 392°F (20.7 bar at 200°C)
Flow Rate	0-10 ft. (0-3 m) per second (fully immersed)
Temperature Compensator	Pt 1000 RTD
Sensor Cable:	
Integral (no junction box)	6 wire cable (4 conductors and two isolated shield wires); 20 ft. (6 m) long
Junction Box Head (optional)	6-position terminal strip supplied in integrally-mounted junction box (polypropylene, aluminum, or 316 stainless steel)

PART TWO - INSTALLATION

SECTION 1

LOCATION REQUIREMENTS

Locate the sensor as close as possible to the measuring instrument. Do not exceed a distance of 300 feet (91 m) between the sensor and instrument.

SECTION 2

MOUNTING

The Model 3444-series high temperature/high pressure style sensor can be mounted directly into a boiler wall, or indirectly into a condensate or process line by using a 316 stainless steel tee of an appropriate size. Figure 2-1 shows the sensor's general dimensions.

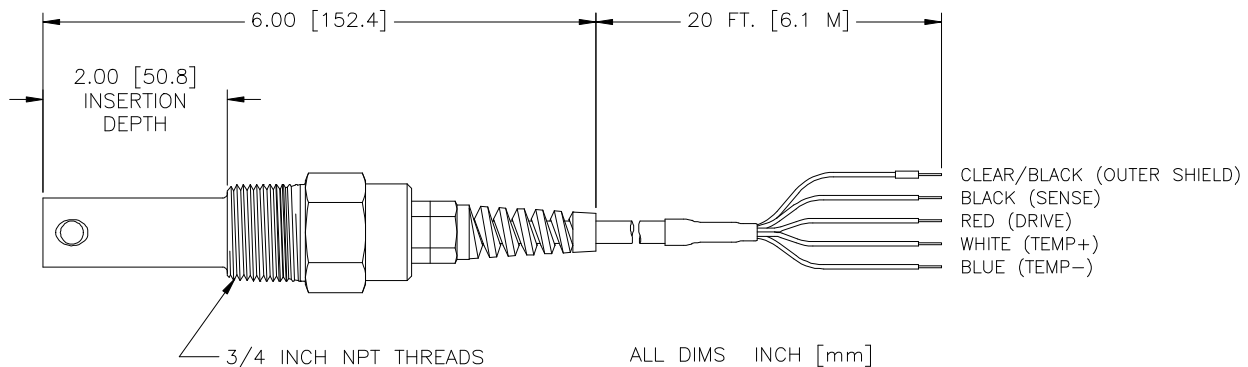

FIGURE 2-1 General Dimensions and Cable Wire Details

To ensure optimum measurement performance, follow these guidelines when mounting the sensor:

- Install the sensor into the vessel or pipe run so that the process flow directly contacts the end of the sensor (see Figure 2-2).
- Preferably, mount the sensor in a vertical position to eliminate the possibility of trapped air bubbles from contacting its electrodes which can cause measurement error. This also prevents loose pipe line sediment from accumulating and obstructing the sensor electrodes.

2.1 Into Vessel Wall Using a Weldolet



1. Refer to Figure 2-2, and install a 3/4-inch NPT weldolet into the vessel wall.
2. Fasten the sensor into the 3/4-inch NPT threaded hole.

NOTE: Use a high temperature thread sealant on the sensor threads to avoid leaks.

3. Electrically connect the sensor to the analyzer. Refer to the analyzer instruction manual for details.
4. Calibrate the analyzer using the procedure in the analyzer instruction manual.

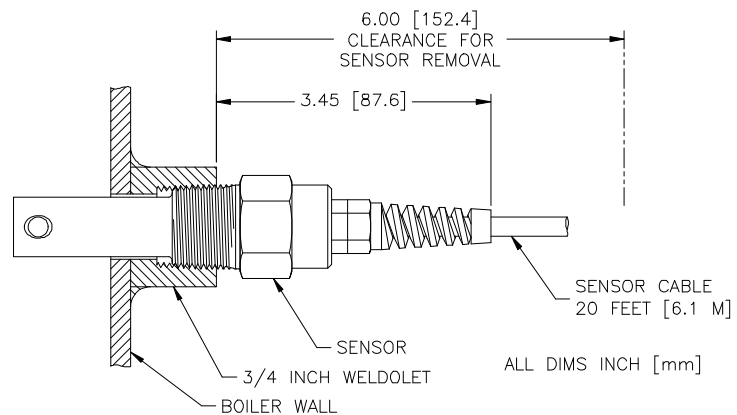

FIGURE 2-2 Installing Sensor Into Vessel Wall Using a Weldolet

2.2 Into Pipe Using a Tee



1. Refer to Figure 2-3, and install a 316 stainless steel pipe tee of appropriate size (1/2 to 2 inches) into the process pipe. **Recommendation:** Use a 3/4-inch pipe tee. If necessary, screw a respectively-sized reducer into the pipe tee.

NOTE: When the sensor is mounted, its “cross flow” holes should be located at the approximate center of the tee for best performance.

Use a high temperature thread sealant on the pipe tee threads to avoid leaks.

2. Electrically connect the sensor to the analyzer. Refer to the analyzer instruction manual for details.
3. Calibrate the analyzer using the procedure in the analyzer instruction manual.
4. Fasten the sensor into the installed pipe tee.

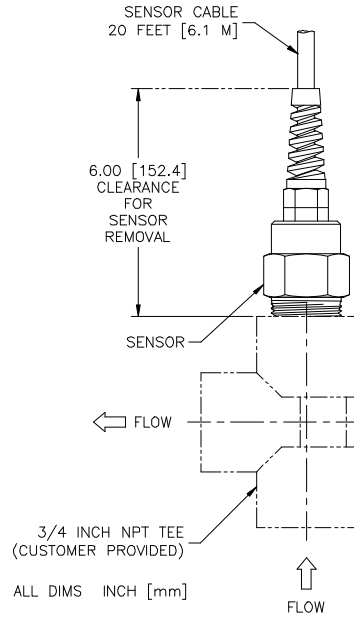

FIGURE 2-3 Installing Sensor Into Pipe Using a Tee

SECTION 3

SENSOR/INTERCONNECT CABLE DETAILS

3.1 Sensor Cable Details

The sensor’s integral cable is a 5-wire Teflon-jacketed cable with 4 conductors and one braided shield wire. Refer to Figure 2-1 for the function and color of each wire in the sensor’s integral cable.

3.2 Interconnect Cable Details

The GLI interconnect cable (part number 1W1100) is provided with unfinished ends since it must often be shortened during installation. This interconnect cable replaces the 99X1W4000 cable which is no longer available. The 1W1100 cable is very similar to the sensor’s integral cable except that it has two additional conductors (green and yellow) which are not required. When stripping the interconnect cable during termination, purposely cut off these green and yellow wires from each end of the stripped-back cable. This ensures the same wire color coding used by the sensor’s integral cable.



NOTE: GLI strongly recommends using only its 1W1100 interconnect cable. If a different cable is used, it must have equivalent construction: four conductors, and two separate isolated shields – one shielding the signal, and one shielding the overall cable. These specific cable characteristics protect the measurement signal from electromagnetic interferences. Using a cable with different construction

may interfere with the measurement system's ability to properly measure.

To correctly terminate the ends of the interconnect cable, refer to Figure 2-4 and follow this procedure:

1. **Carefully** strip back 2-1/4 inches of the outer cable jacket, the outer shield foil, and the cellophane binder. This exposes the sensor shield wire, the inner shield wire, and the three foil-wrapped wire pairs.
2. Cut off the exposed 2-1/4 inches of only the yellow and green wire pair.
3. Peel back and cut off the exposed inner shield foil from the red/black and blue/white wire pairs.
4. **Carefully** strip back an additional 1/2 inch of the outer cable jacket and outer shield foil.



NOTE: *Be careful not to damage the exposed section of the cellophane binder.*

5. Carefully position a 2-1/2 inch long piece of shrink tubing or tape on the bare sensor shield wire 1/4-inch from the end as shown in Figure 2-4 to insulate and distinguish it from the inner shield wire. Doing this exposes 1/4-inch of bare shield wire beyond the tubing or tape for connection purposes.

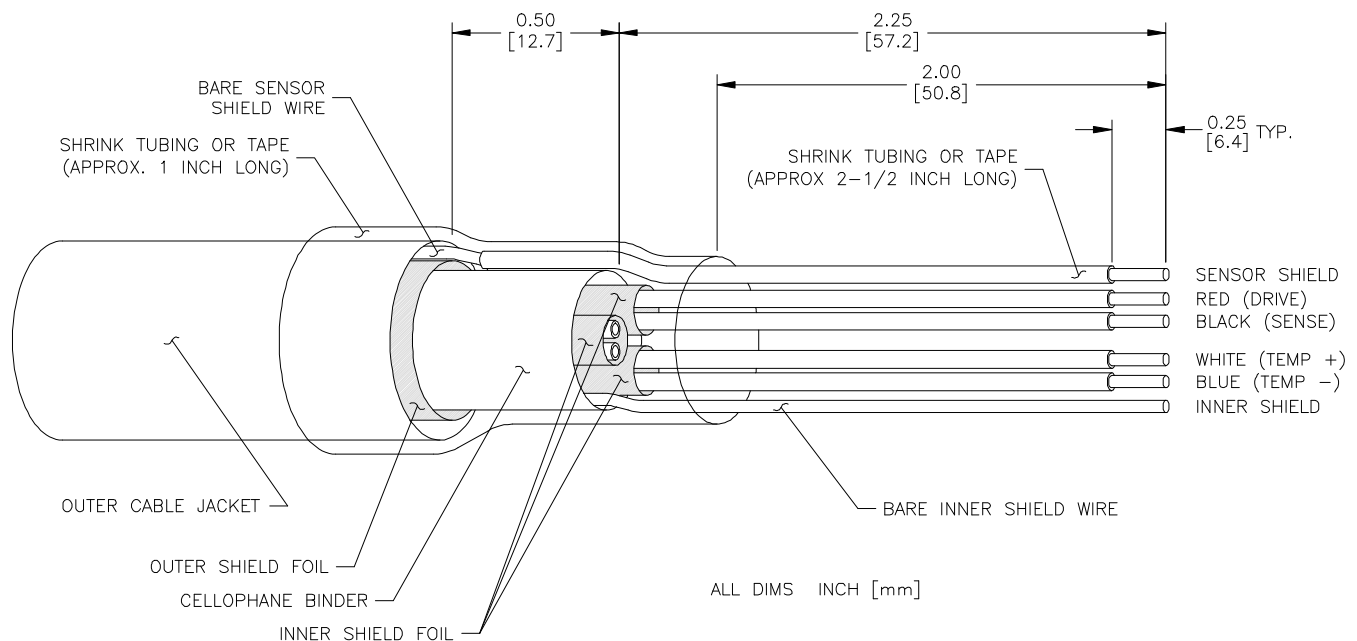

Figure 2-4 Interconnect Cable Termination Details



6. Carefully position a 1-inch long piece of shrink tubing or tape on the cable as shown in Figure 2-4 to secure all wires.

NOTE: *Do not fold back the cellophane binder exposed in step 4.*

7. Using an ohmmeter or test light, verify that the sensor shield wire you insulated is not shorted to the bare inner shield wire. If the wires are shorted, cut the cable to get a new unfinished end and start over at step 1.
8. Strip 1/4 inch of insulation from the ends of the red, black, white, and blue wires. Tin these leads, the insulated sensor shield wire, and the bare inner shield wire with solder.
9. Connect the interconnect cable to the analyzer in the same way as the sensor cable, by matching colors as indicated.

3.3 Connecting Interconnect Cable

- **To Integral Junction Box Head:** Connect the four colored wires and two shields of the interconnect cable to the six terminals inside the junction box head, following the wire designations shown inside the junction box cover.
- **To Analyzer:** Refer to the instrument instruction manual and connect the interconnect cable wires to appropriate SENSOR terminals in the same way as the sensor wires would be directly connected.

PART THREE - SERVICE AND MAINTENANCE

SECTION 1

RECOMMENDED CLEANING PROCEDURE

Keep the sensor reasonably clean to maintain measurement accuracy. The time between cleanings (days, weeks, etc.) is affected by the characteristics of the process solution and can only be determined by operating experience.

1. Remove most contaminate buildup by carefully wiping the inner electrode rod, and the concentric outer electrode tube (inner and outer surfaces) with a soft clean cloth. Then rinse the sensor with clean, warm water.
2. Prepare a mild soap solution. Use warm water and dish-washing detergent, Borax hand soap, or a similar soap.
3. Soak the sensor for 2 to 3 minutes in the soap solution.
4. Use a small bristle brush, cotton swab (Q-tip), or pipe cleaner to scrub the entire measuring end of the sensor, thoroughly cleaning the electrode surfaces. If detergent solution cleaning cannot remove surface deposits, use muriatic acid (or another dilute acid) to dissolve the deposits. The acid should be as dilute as possible, but yet strong enough to clean. Experience will help determine which acid to use and how dilute it can be. Some stubborn coatings may require a different cleaning agent. For assistance in these difficult cases, contact the GLI Service Department.

Before cleaning with acid, determine if any hazardous reaction products could form. (Example: A sensor used in a cyanide bath should not be put directly into a strong acid for cleaning because poisonous cyanide gas could be produced.) Acids are hazardous. Wear appropriate eye protection and clothing in accordance with Material Safety Data Sheet recommendations.

Soak the sensor in dilute acid for **no more than 5 minutes**. Rinse the sensor with clean, warm water and then place the sensor back into the mild soap solution for 2 to 3 minutes to neutralize any remaining acid.

5. Rinse the sensor in clean, warm water.
6. Calibrate the analyzer using the procedure in the analyzer instruction manual. If calibration cannot be attained, check the sensor using the procedure in Part Three, Section 2.1.

SECTION 2

TROUBLESHOOTING

2.1 Checking Sensor Operation

Use the troubleshooting section in the analyzer instruction manual to determine whether the sensor or analyzer is inoperative. If you suspect the sensor, check it using the following procedure:

1. Disconnect the sensor from the analyzer (or junction box, if using interconnect cable).
2. Clean the sensor using the procedure in Part Three, Section 1.
3. Using an ohmmeter, check all of the measurement point resistance readings shown in Table A below.



NOTE: Be sure that the ohmmeter is set to its highest range for all infinite (open circuit) resistance readings shown in Table A.

Table A -- SENSOR OPERATIONAL (RESISTANCE) CHECKS	
Measurement Points	Correct Resistance Readings
Between blue and white wires	1089-1106 ohms at 23-27°C
Between red wire and sensor body	Less than 5 ohms
Between black wire and inner electrode	Less than 5 ohms
Between black and red wires	Infinite (open circuit)
Between black and white wires	Infinite (open circuit)
Between red and white wires	Infinite (open circuit)
Between red and outer shield wires	Infinite (open circuit)
Between black and outer shield wires	Infinite (open circuit)
Between white and outer shield wires	Infinite (open circuit)
Between outer and outer shield wires	Infinite (open circuit)

4. If you cannot get the required readings for one or more of the resistance checks in step 3, the sensor is probably inoperative. Refer to GLI's warranty/replacement plan on page 4 for sensor replacement details. If all resistance checks are okay, the sensor may still be inoperative. In this case, more extensive troubleshooting is required. Please consult the GLI Customer Service Department for details.

2.2 Customer Assistance

If you need assistance in troubleshooting or repair service, please contact your local GLI representative, or the GLI Customer Service Department at:

GLI International, Inc. Telephone: [800] 543-8907
 9020 West Dean Road Telefax: [414] 355-8346
 Milwaukee, Wisconsin 53224

— GLI SERVICE DEPARTMENT HOURS —

	Eastern Std. Time	Central Std. Time	Mountain Std. Time	Pacific Std. Time
Monday through Thursday	8:30 a.m. to 5:30 p.m.	7:30 a.m. to 4:30 p.m.	6:30 a.m. to 3:30 p.m.	5:30 a.m. to 2:30 p.m.
Friday	8:30 a.m. to 4:00 p.m.	7:30 a.m. to 3:00 p.m.	6:30 a.m. to 2:00 p.m.	5:30 a.m. to 1:00 p.m.

All sensors returned for repair or replacement must be freight prepaid and include the following information:

1. A clearly written description of the malfunction.
2. Name of person to contact and the phone number where they can be reached.
3. Proper return address for shipping sensor(s) back. Include preferred shipping method (UPS, Federal Express, etc.) if applicable.
4. A purchase order if sensor(s) is out of warranty to cover costs of repair.



NOTE: *If the sensor is damaged during return shipment as a result of inadequate packaging, the customer assumes responsibility for repair costs. It is recommended to use the original GLI shipping carton or an equivalent. Also, GLI will not accept sensors returned for repair or replacement unless they are thoroughly cleaned and all process chemicals are removed.*