

Mini Environmental Quality Meter

850025

SPER
SCIENTIFIC

Environmental Measurement Instruments

7720 E. Redfield Rd. Suite #7,
Scottsdale, AZ 85260

Tel: (480) 948-4448 | Fax: (480) 967-8736

Web: www.sperscientific.com

Mini Environmental Quality Meter 850025

Copyright ©2012 by
Sper Scientific
ALL RIGHTS RESERVED
Printed in the USA

The contents of this manual may not be reproduced or transmitted in any form or by any means electronic, mechanical, or other means that do not yet exist or may be developed, including photocopying, recording, or any information storage and retrieval system without the express permission from Sper Scientific.

Sper Scientific
7720 E. Redfield Rd. Suite #7,
Scottsdale, AZ 85260
Tel: (480) 948-4448
Fax: (480) 967-8736
Web: www.sperscientific.com

TABLE OF CONTENTS

1. INTRODUCTION4
2. MATERIALS SUPPLIED.4
3. FEATURES5
4. FRONT PANEL DESCRIPTION6
5. OPERATING INSTRUCTIONS.7
Power on/off7
LCD backlight on/off7
Mode selection7
Unit selection8
Special attention for the Humidity measurement9
Hold Function	10
REC (Record) function	10
Auto power off disable	11
6. BATTERY REPLACEMENT.	12
7. SPECIFICATIONS.	13
8. WARRANTY	16

INTRODUCTION

For environmental testing anywhere. Model 850025 combines an anemometer, humidity meter and thermometer into a single compact unit. Features include touch-tone buttons, min/max and hold functions. Comes ready to use with wrist strap, instructions, battery and soft carrying case.

MATERIALS SUPPLIED

Meter

Wristlet

CR 2032 DC 3V Battery

Soft Carrying Case

FEATURES

- 3 professional environmental instruments in 1: Air velocity, Humidity and Temperature
- Lightweight, ergonomic design
- Wristlet design provides extra protection to the instrument
- Low-friction ball bearing mounted impeller design provides high accuracy at high and low air velocity
- High precision humidity sensor with fast response time
- Built-in microprocessor circuit assures excellent performance and accuracy
- Concise and compact buttons arrangement for easy operation.
- Maximum and minimum memory with recall
- Hold function
- °C/°F selection

FRONT PANEL DESCRIPTION

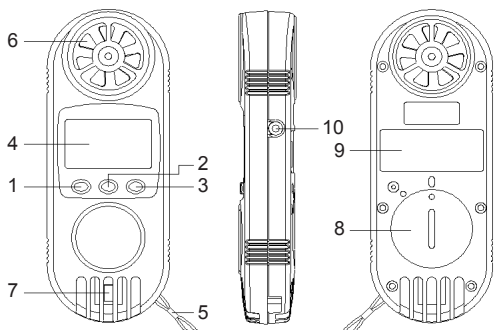

- 1 Hold button
- 2  Button (Power button)
- 3 REC button
- 4 LCD display
- 5 Wristlet
- 6 Anemometer vane
- 7 Humidity/Temperature sensor
- 8 Battery compartment cover
- 9 Buttons operation label
- 10 Anemometer temperature sensor

OPERATING INSTRUCTIONS

Power on/off

⏻ Button = Power Button

1. Power on: Press ⏻ once to turn meter on.
2. Power off: Press ⏻ for > 3 seconds to turn meter off.

LCD backlight on/off

With the meter on, press ⏻ once. The LCD backlight will light for 5 seconds, then shut off automatically.

Mode selection

This meter offers 2 selectable modes:

- a. Anemometer (Air velocity)
/Temperature
- b. Humidity/Temperature

With the meter on, press **HOLD** continuously and the Display will show the following texts in sequence:

Display Mode text

An = Anemometer (Air velocity)/
Temperature

rH = Humidity/ Temperature

When the display shows the desired mode, release **HOLD** and the meter will set this mode as the default.

An Mode Selection

REC button = Enter button

1. With the power on, press **REC** for >3 seconds, the display will show Unit. Release **REC**, then press \odot to scroll through the available scales. After the desired scale is selected, press **REC** to save as the default.
2. The next screen displays “dCdF” with the current temperature scale selection ($^{\circ}\text{C}$ or $^{\circ}\text{F}$) below. Press \odot to

select the desired scale.
Press **REC** to save as
the default.

Note...

When rH is the selected mode,
you may only adjust the
temperature scale setting.
(°C or °F)

The selection scales for all modes are:

Measurement	Scales
Air Velocity	m/s, Km/h, mph, knot, FPM
Temp. (Air velocity)	°C/°F
Temp. (Humidity)	°C/°F

Note...

For the most accurate humidity
measurement, do not touch or
block the humidity sensor at any
time with your hand.

Hold Function

Pressing **Hold** will freeze the current reading on the display. The HOLD symbol will be displayed at the top of the display window.

To release the Hold function, press **Hold** again, the HOLD indicator will disappear and the current reading will be displayed.

REC (Record) function

The **REC** (Record) function will record and display the maximum and minimum readings.

1. Start the Record function by pressing **REC** once. The REC symbol will appear on the display.
2. With the REC symbol on the display:
 - a. Press **REC** once and the Max symbol will appear on

- the display along with the current maximum value.
- b. Press **REC** again, the MIN symbol will appear on the display along with the current minimum value.
 - c. Clear the recorded MAX or MIN value from the display by pressing **Hold** once. The MAX/MIN symbols and their readings, will disappear from the display. The meter will return to the REC function and continue recording.
 - d. To exit REC function press **REC** button for >2 seconds.

Auto power off disable

In order to prolong the battery life, this instrument has an Auto Power Off function: the meter will turn off if no buttons are pressed for approximately 10 minutes.

To disable the Auto Power Off function, press **REC** and enter the record function (page 10). The Auto power off function will be disabled until the record function is exited.

REPLACE BATTERY

1. When the LCD display shows  symbol, it is time to replace the battery. (Measurements may still be made for several hours after the low battery indicator appears.)
2. Open the Battery Compartment and remove the battery.
3. Install the battery (CR2032) and replace the cover.

GENERAL SPECIFICATIONS

Display	8 mm LCD display
Measurement	1. Anemometer (Air velocity)/ Temperature 2. Humidity/ Temperature
Operating Humidity	Max. 80% RH
Operating Temperature	0 ~ 50°C (32 ~ 122°F)
Over Input Display	“-----”
Power Supply	CR 2032 DC 3V battery
Power Consumption	Approx. DC 5 mA
Weight	160 g (battery included)
Dim (HWD)	4.7" x 1.8" x 1.2" (120 x 45 x 20 mm)
Standard Accessories	Instruction Manual, battery, soft case

ELECTRICAL SPECIFICATIONS

Air Velocity			
Unit	Range	Res.	Acc.
ft/min	80 ~ 3927	1	±3% F.S.
m/s	0.4 ~ 20.0	0.1	
km/h	1.4 ~ 72.0	0.1	
mph	0.9 ~ 44.7	0.1	
knots	0.8 ~ 38.8	0.1	
Temp. °C/°F	0 ~ 50°C	0.1°C	± 1.2
	32 ~ 122°F	0.1°F	± 2.5

ft/min: feet per minute

m/s: meters per second

km/h: kilometers per hour

mph: miles per hour

knots: nautical miles per hour

ELECTRICAL SPECIFICATIONS

Humidity/Temperature			
Unit	Range	Res.	Acc.
%RH	10 to 95 %RH	0.1 % RH	< 70 %RH: ±4 %RH ≥70 %RH: ± (4% rdg +1.2 %RH)
Temp. °C/°F	0~50	0.1°C	± 1.2°C
	32~122	0.1°F	± 2.5°F

WARRANTY

Sper Scientific warrants this product against defects in materials and workmanship for a period of five (5) years from the date of purchase, and agrees to repair or replace any defective unit without charge. If your model has since been discontinued, an equivalent Sper Scientific product will be substituted if available. This warranty does not cover probes, batteries, battery leakage, or damage resulting from accident, tampering, misuse, or abuse of the product.

To obtain warranty service, ship the unit postage prepaid to:

SPER SCIENTIFIC LTD.
7720 E Redfield Rd, Suite 7
Scottsdale, AZ 85260

The defective unit must be accompanied by a description of the problem and your return address. Register your product online at www.sperscientific.com, or return your warranty card within 10 days of purchase.

Revised 08/23/12