



Method 10067

Manganese III Reactor Digestion Method (without chloride removal)*

(30-1000 mg/L)

Scope and Application: For water and wastewater.

* U.S. Patent 5,556,787 on method

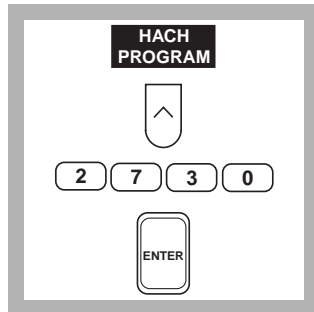

1. Press the soft key under **HACH PROGRAM**.

Select the stored program number for Manganese III COD by pressing **2730** with the numeric keys.

Press: **ENTER**



2. The display will show: **HACH PROGRAM: 2730 COD, Mn III**

The wavelength (λ), **510 nm**, is automatically selected.



3. Turn on the COD Reactor and heat to 150 °C. Place the shield in front of the reactor.

Note: To determine if the sample contains chloride, use Quantab Titrator Strips for Low range Chloride. If the sample contains chloride, use the chloride removal method (follows this method).



4. Homogenize 100 mL of sample for 30 seconds in a blender.

Note: Continue mixing the sample while pipetting if suspended solids are present.

Note: To store samples, see Sample Collection, Preservation and Storage in the Manganese III Digestion Method (with optional chloride removal) following this procedure.

OXYGEN DEMAND, Chemical, continued

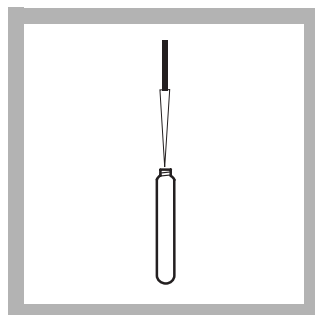

5. Pipet 0.50 ml of homogenized sample into a Mn III COD vial. Cap and invert several times to mix.

Note: If the sample COD value is not between 30-1000 mg/L, dilute the sample with deionized water to obtain this range. Multiply the final result by the dilution factor.

PREPARE BLANK

6. Prepare a blank by substituting 0.50 mL of deionized water for the sample.

Note: The reagent blank is stable and can be reused. Verify reagent blank quality by measuring the absorbance of the blank vs. a clean COD vial filled with deionized water. The absorbance range should be about 1.4–1.5.

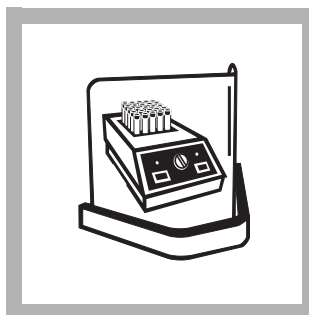

7. Place the vials in the COD Reactor preheated to 150 °C. Digest for 1 hour.

Note: Boiling sample in the vials during digestion indicates the vial is not properly sealed; test results will be invalid.

Note: To oxidize more resistant organics, digest samples up to 4 hours. Treat the blank in the same manner.

Note: Ensure safety devices are in place to protect the analyst from splattering if leaks occur. Spilled reagent will affect test accuracy and is hazardous. Do not run tests with vials which have been spilled.

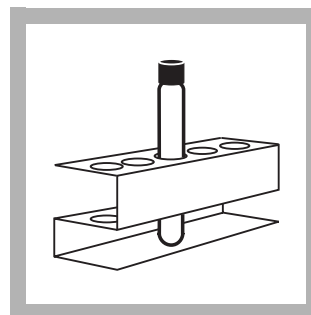

8. Remove the vials and place them in a cooling rack for two minutes to air cool. Then cool the vials to room temperature in a cool water bath or running tap water. This usually takes about 3 minutes.

Note: Occasionally a vial will develop a colorless upper layer and a purple lower layer. Invert the vial several times to mix and proceed.

Note: The Hach COD Vial Lifter allows the transfer of several vials at once.

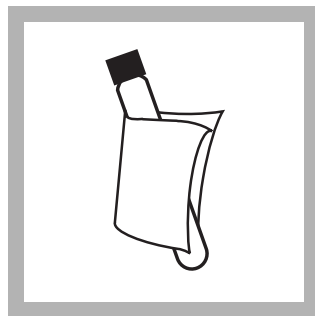

9. Remove the vials from the water and wipe with a clean, dry paper towel. Invert the vials several times to mix.



10. Insert the COD Vial Adapter into the sample cell module by sliding it under the thumb screw and into the alignment grooves. Fasten with the thumb screw.

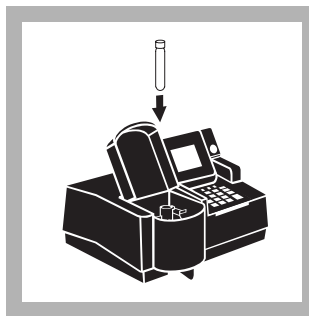

11. Place the blank into the sample cell compartment. Close the light shield.

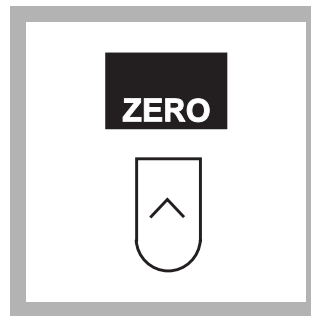

12. Press the soft key under **ZERO**.

The display will show:

0 mg/L COD

Note: For alternate concentration units, press the soft key under **OPTIONS**. Then press the soft key under **UNITS** to scroll through the available options. Press **ENTER** to return to the read screen.



13. Place the sample vial in the adapter. Close the light shield. Results in mg/L COD (or chosen units) will be displayed.

Note: Results may be expressed as mg/L COD or mg/L O₂. Press the soft keys under **OPTIONS**, then under **FORM**: to scroll through the available choices.

Additional Information

For information about sampling, storage, accuracy checks, interferences, method summary, reagents and apparatus, see the *Manganese III Digestion Method (with optional chloride removal)* following this procedure.



FOR TECHNICAL ASSISTANCE, PRICE INFORMATION AND ORDERING:

In the U.S.A. – Call toll-free 800-227-4224

Outside the U.S.A. – Contact the HACH office or distributor serving you.

On the Worldwide Web – www.hach.com; E-mail – techhelp@hach.com

HACH COMPANY
WORLD HEADQUARTERS
Telephone: (970) 669-3050
FAX: (970) 669-2932