



DOC343.52.90690

SC4500

06/2024, Edition 10

User Manual

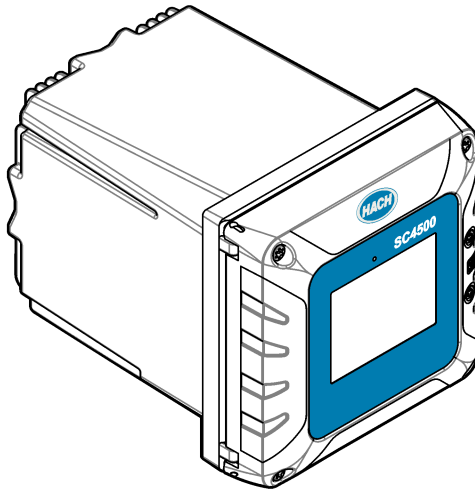

Section 1 Specifications	3
Section 2 General information	4
2.1 Safety information	4
2.1.1 Use of hazard information	4
2.1.2 Precautionary labels	4
2.1.3 EMC compliance	5
2.2 Product overview	6
2.2.1 Optional expansion modules	7
2.3 Product components	8
Section 3 Installation	8
3.1 Installation guidelines	9
3.2 Mechanical installation	9
3.2.1 Attach the instrument to a wall	9
3.2.2 Attach the instrument to a pole	10
3.2.3 Install the instrument in a panel	11
3.3 Electrical installation	12
3.3.1 Electrical connectors and fittings	12
3.3.2 Electrostatic discharge (ESD) considerations	14
3.3.3 Power connections	14
3.3.3.1 Open the controller cover	14
3.3.3.2 Remove the high-voltage barrier	15
3.3.3.3 Wiring for power	15
3.3.3.4 Connect conduit or a power cord	17
3.3.4 Connect the high-voltage relays	18
3.3.5 Install an expansion module	20
3.4 Close the cover	20
3.5 Connect measurement devices	21
Section 4 User interface and navigation	22
4.1 Measurement window	23
4.2 Graph	24
Section 5 Startup	25
5.1 Menu structure	26
5.2 Enter initial settings	27
Section 6 Operation	27
6.1 Configure the controller settings	27
6.2 Configure menu access	27
6.3 Connect the instrument to a network	28
6.3.1 LAN connection	28
6.3.2 WiFi network connection	29
6.3.3 Cellular network connection	29
6.3.3.1 Configuration with Hach Cellular (Telenor) SIM	29
6.3.3.2 Configuration with customer supplied SIM	30
6.4 Configure the sensors or analog inputs	30
6.5 Connect a USB flash drive (optional)	31
6.5.1 Data download	31

Table of Contents

6.5.2	Install controller firmware updates	32
6.5.3	Install sensor firmware updates	33
6.5.4	Restore the controller firmware	33
6.5.5	Manage a software module	34
6.5.5.1	Install a software module	34
6.5.5.2	Delete a software module	34
6.5.5.3	Install a firmware update for an RTC module	34
6.6	Configure the outputs	35
6.6.1	Configure the high voltage relays	35
6.6.2	Configure the analog outputs	40
6.6.3	Configure the Modbus RS232/RS485	42
6.6.3.1	Diagnostics/Test menu—Modbus RS232/RS485	43
6.6.4	Configure the telegram	43
6.6.5	Configure the Modbus TCP	44
6.6.6	Configure the Profibus DP	45
6.6.7	Configure the EtherNet/IP	46
6.6.8	Configure the PROFINET	46
6.6.9	Hold or release the analog outputs	47
6.7	Hach Controller Network Bus configuration	47
6.8	Prognosys diagnostic system	47
6.9	Claros	48
6.10	Enter license key	48
6.11	Show the instrument information	48
Section 7	Maintenance	49
7.1	Clean the instrument	49
7.2	Unlock the controller cover	49
7.3	Fuse replacement	49
7.4	Battery replacement	50
Section 8	Troubleshooting	50
Section 9	Replacement parts and accessories	53
Appendix A	Telegram tag list	55
Appendix B	Open-source code and licenses	77

Section 1 Specifications

Specifications are subject to change without notice.

Specification	Details
Dimensions (W x H x D)	½ DIN-144 x 144 x 192 mm (5.7 x 5.7 x 7.6 in.)
Enclosure	UL50E type 4X, IEC/EN 60529–IP 66, NEMA 250 type 4X Metal enclosure with a corrosion-resistant finish
Weight	1.7 kg (3.7 lb) (Controller weight without optional expansion modules)
Pollution degree	Environment: 4; instrument: 2
Overvoltage category	II
Protection class	I, connected to protective earth
Environmental conditions	Indoor and outdoor use
Power requirements	AC controller: 100–240 VAC ±10%, 50/60 Hz; 1 A (50 VA with 8W sensor load, 100VA with 28W sensor load) DC controller: 18–28 VDC; 2.5 A (12W with 9W sensor load, 36W with 20 W sensor load)
Operating temperature	–20 to 60 °C (–4 to 140 °F) (8 W (AC)/9 W (DC) sensor load) –20 to 45 °C (–4 to 113 °F) (28 W (AC)/20 W (DC) sensor load) Linear derating between 45 and 60 °C (–1.33 W/°C)
Storage temperature	–20 to 70 °C (–4 to 158 °F)
Relative humidity	0 to 95%, non-condensing
Altitude	3000 m (9842 ft) maximum
Display	3.5-inch TFT color display with capacitive touchpad
Measurement	Two device, digital SC connectors
Relays (high voltage)	Two relays (SPDT); Wire gauge: 0.75 to 1.5 mm ² (18 to 16 AWG) AC controller Maximum switching voltage: 100–240 VAC Maximum switching current: 5 A Resistive/1 A Pilot Duty Maximum switching power: 1200 VA Resistive/360 VA Pilot Duty DC controller Maximum switching voltage: 30 VAC or 42 VDC Maximum switching current: 4 A Resistive/1 A Pilot Duty Maximum switching power: 125 W Resistive/28 W Pilot Duty
Analog inputs (optional) ³	One 0–20 mA (or 4–20 mA) analog input on each analog input module One analog sensor input on each sensor module Maximum of two analog inputs
Analog outputs (optional) ³	Five 0–20 mA (or 4–20 mA) analog outputs on each analog output module ¹
Digital communication (optional) ³	Profibus DPV1 module, Modbus RS232/RS485 module, Modbus TCP, PROFINET module, EtherNet/IP™ ² module

¹ Refer to the module documentation for additional information.

Note: Install only one module in one of the available slots.

² EtherNet/IP is a trademark of OVDA Inc.

Specification	Details
Software module (optional)	Contact sales or technical support for information. Note: Only one software module can be installed on a controller at the same time.
Network connection ³	LAN version (optional): Two Ethernet connectors (10/100 Mbps), M12 female D-coding connector; Cellular version and WiFi version (optional) ⁴
USB port	Used for data download and software upload. The controller records approximately 20,000 data points for each connected sensor.
Compliance information	CE, ETL certified to UL and CSA safety standards (with all sensor types), FCC, ISED, KC, RCM, EAC, UKCA, SABS, CMIM, Morocco
Warranty	1 year (EU: 2 years)

Section 2 General information

In no event will the manufacturer be liable for damages resulting from any improper use of product or failure to comply with the instructions in the manual. The manufacturer reserves the right to make changes in this manual and the products it describes at any time, without notice or obligation. Revised editions are found on the manufacturer's website.

2.1 Safety information

The manufacturer is not responsible for any damages due to misapplication or misuse of this product including, without limitation, direct, incidental and consequential damages, and disclaims such damages to the full extent permitted under applicable law. The user is solely responsible to identify critical application risks and install appropriate mechanisms to protect processes during a possible equipment malfunction.

Please read this entire manual before unpacking, setting up or operating this equipment. Pay attention to all danger and caution statements. Failure to do so could result in serious injury to the operator or damage to the equipment.

Make sure that the protection provided by this equipment is not impaired. Do not use or install this equipment in any manner other than that specified in this manual.

2.1.1 Use of hazard information

▲ DANGER
Indicates a potentially or imminently hazardous situation which, if not avoided, will result in death or serious injury.

▲ WARNING
Indicates a potentially or imminently hazardous situation which, if not avoided, could result in death or serious injury.

▲ CAUTION
Indicates a potentially hazardous situation that may result in minor or moderate injury.





NOTICE
Indicates a situation which, if not avoided, may cause damage to the instrument. Information that requires special emphasis.

2.1.2 Precautionary labels

Read all labels and tags attached to the instrument. Personal injury or damage to the instrument could occur if not observed. A symbol on the instrument is referenced in the manual with a precautionary statement.

³ Dependent on controller configuration.

⁴ An external USB box WiFi is necessary for network connection on WiFi versions. An external USB box cellular is necessary for network connection on cellular versions.

	This is the safety alert symbol. Obey all safety messages that follow this symbol to avoid potential injury. If on the instrument, refer to the instruction manual for operation or safety information.
	This symbol indicates that a risk of electrical shock and/or electrocution exists.
	This symbol indicates the presence of devices sensitive to Electro-static Discharge (ESD) and indicates that care must be taken to prevent damage with the equipment.
	Electrical equipment marked with this symbol may not be disposed of in European domestic or public disposal systems. Return old or end-of-life equipment to the manufacturer for disposal at no charge to the user.

2.1.3 EMC compliance

⚠ CAUTION
This equipment is not intended for use in residential environments and may not provide adequate protection to radio reception in such environments.

CE (EU)

The equipment meets the essential requirements of EMC Directive 2014/30/EU.

UKCA (UK)

The equipment meets the requirements of the Electromagnetic Compatibility Regulations 2016 (S.I. 2016/1091).

Canadian Radio Interference-Causing Equipment Regulation, ICES-003, Class A:

Supporting test records reside with the manufacturer.

This Class A digital apparatus meets all requirements of the Canadian Interference-Causing Equipment Regulations.

Cet appareil numérique de classe A répond à toutes les exigences de la réglementation canadienne sur les équipements provoquant des interférences.

FCC Part 15, Class "A" Limits

Supporting test records reside with the manufacturer. The device complies with Part 15 of the FCC Rules. Operation is subject to the following conditions:

1. The equipment may not cause harmful interference.
2. The equipment must accept any interference received, including interference that may cause undesired operation.

Changes or modifications to this equipment not expressly approved by the party responsible for compliance could void the user's authority to operate the equipment. This equipment has been tested and found to comply with the limits for a Class A digital device, pursuant to Part 15 of the FCC rules. These limits are designed to provide reasonable protection against harmful interference when the equipment is operated in a commercial environment. This equipment generates, uses and can radiate radio frequency energy and, if not installed and used in accordance with the instruction manual, may cause harmful interference to radio communications. Operation of this equipment in a residential area is likely to cause harmful interference, in which case the user will be required to correct the interference at their expense. The following techniques can be used to reduce interference problems:

1. Disconnect the equipment from its power source to verify that it is or is not the source of the interference.
2. If the equipment is connected to the same outlet as the device experiencing interference, connect the equipment to a different outlet.
3. Move the equipment away from the device receiving the interference.
4. Reposition the receiving antenna for the device receiving the interference.
5. Try combinations of the above.

2.2 Product overview

⚠ DANGER	
	<p>Chemical or biological hazards. If this instrument is used to monitor a treatment process and/or chemical feed system for which there are regulatory limits and monitoring requirements related to public health, public safety, food or beverage manufacture or processing, it is the responsibility of the user of this instrument to know and abide by any applicable regulation and to have sufficient and appropriate mechanisms in place for compliance with applicable regulations in the event of malfunction of the instrument.</p>

NOTICE
<p>Network and access point security is the responsibility of the customer that uses the wireless instrument. The manufacturer will not be liable for any damages, inclusive however not limited to indirect, special, consequential or incidental damages, that have been caused by a gap in, or breach of network security.</p>

NOTICE
<p>Perchlorate Material—Special handling may apply. Refer to www.dtsc.ca.gov/perchlorate. This perchlorate warning applies only to primary batteries (provided singly or installed on this equipment) when sold or distributed in California, USA.</p>

NOTICE
<p>The controller is supplied with a protection foil installed on the display. Make sure to remove the protection foil before the controller is used.</p>

The SC4500 Controller is a 2-channel controller for digital analytical devices (e.g., sensors and analyzers) and analog sensors that are connected to a digital gateway or expansion module. Refer to [Figure 1](#).

The controller shows sensor measurements and other data on the display, can transmit analog and digital signals, and can interact with and control other devices through outputs and relays. Outputs, relays, sensors and expansion modules are configured and calibrated through the user interface on the front of the controller or remotely for network connected controllers. The controller connects to Claros with a cellular network⁵, WiFi network⁵ or through LAN connection. The Prognosys diagnostic system⁵ shows the status of maintenance tasks and gives the status of the instrument condition.

The instrument display is a touchscreen. The instrument enclosure has a protective vent in the bottom. Do not cover or remove the protective vent. Replace the protective vent if damage is seen.

Note: Some controller configurations have two Ethernet ports for LAN connectivity or for Modbus TCP/IP based fieldbus communication with PLC/SCADA. Refer to [LAN connection](#) on page 28.

The controller is available with optional expansion modules. Refer to [Optional expansion modules](#) on page 7.

Figure 1 Product overview

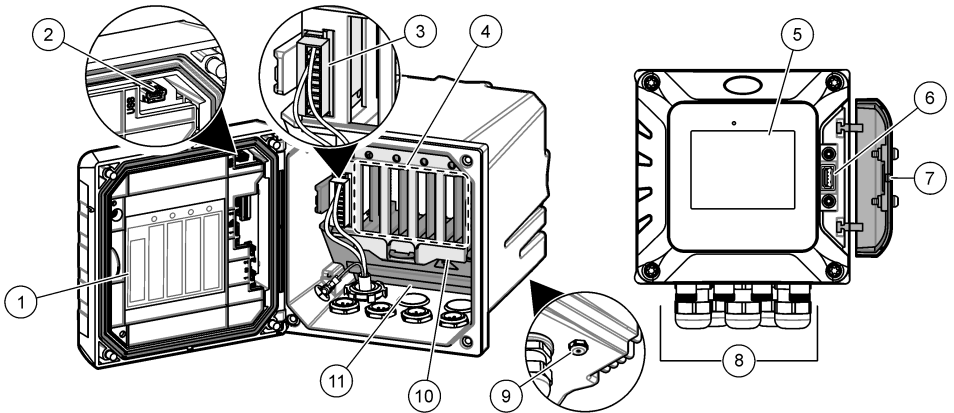

1 Label for module installation and wiring information	7 USB cover
2 USB connection for external USB box (WiFi or cellular connection)	8 Electrical connections and fittings
3 Expansion module (Slot 0) ⁵	9 Protective vent
4 Additional expansion module slots (Slots 1, 2, 3 and 4)	10 Cover for module installation
5 Touchpad display	11 High-voltage barrier
6 USB connection for data download and firmware update	

2.2.1 Optional expansion modules

The controller is available with optional expansion modules:

- Profibus DP module (Slot 0)—Used to connect the controller to a Profibus DP (decentralized peripherals) network. Profibus DP is used to operate sensors and actuators with a centralized controller in production (factory) automation applications.
- Modbus RS232/RS485 module (Slot 0)—Used to connect the controller to a Modbus RS232/RS485 network.
- 4–20 mA output module (Slot 1)—Used for analog signaling or to control other external devices.
Note: Only one 4–20mA output module can be installed.
- EtherNet/IP module (Slot 2)—The controller can connect to a PLC through Industrial Ethernet Protocol including a EtherNet/IP solution. Line, Star and Ring topologies are available.
- PROFINET module (Slot 2)—The controller can connect to a PLC through the Industrial Ethernet Protocol, which includes a PROFINET solution. Line, Star and Ring topologies are available.
- 4–20 mA input module (Slot 3 or 4)—Lets the controller accept one analog input (0–20 mA or 4–20 mA) from an external device.
- pH/ORP and conductivity modules (Slot 3 or 4)—Lets the controller accept measurements from one pH, ORP or conductivity analog sensor.
- Amperometry module (Slot 3)—Lets the controller accept measurements from the dissolved oxygen sensor of the 2582sc analyzer or the electrodes for the oxygen scavenger application used in the 2586sc analyzer.

Note: An expansion module can be installed in only one of Slots 0, 1 and 2.

⁵ Dependent on controller configuration. The expansion modules are factory-installed based on controller configuration.

Note: Only two input devices⁶ can be connected to the controller at the same time. If more than two input devices are connected, the controller will only see two of the devices. Refer to Sensor is not recognized in [Troubleshooting](#) on page 50.

2.3 Product components

Make sure that all components have been received. Refer to [Figure 2](#). If any items are missing or damaged, contact the manufacturer or a sales representative immediately.

Figure 2 Product components

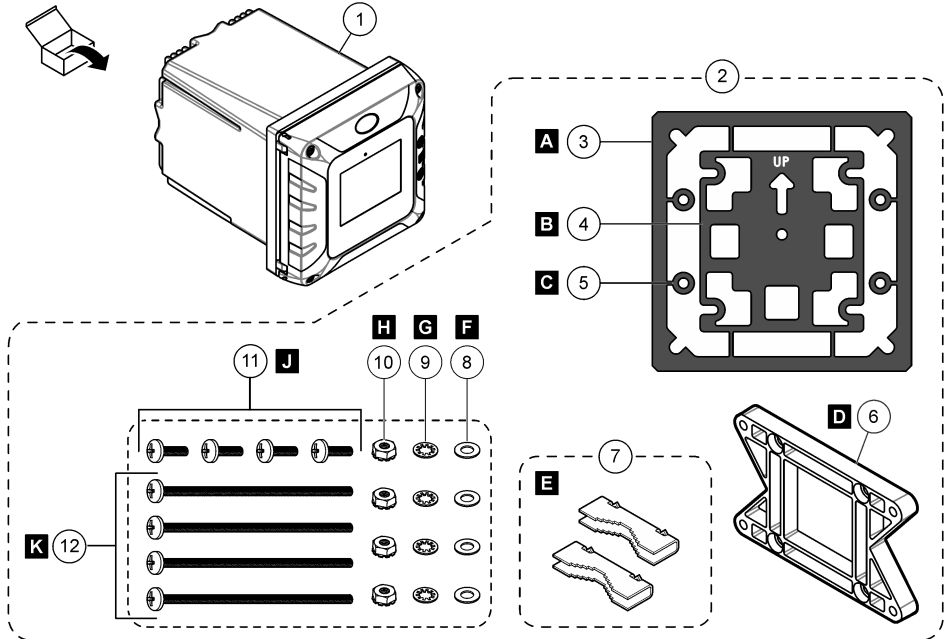

1 SC4500 controller	7 Mounting foot (mounting bracket inserts) (2x)
2 Mounting hardware	8 Flat washer, ¼-inch ID (4x)
3 Sealing gasket for panel mount, Neoprene	9 Lock washer, ¼-inch ID (4x)
4 Vibration isolation gasket for pipe mount	10 Keps hexnut, M5 x 0.8 (4x)
5 Vibration isolation washer for pipe mount (4x)	11 Pan head screws, M5 x 0.8 x 15 mm (4x)
6 Bracket for wall and pipe mounting ⁷	12 Pan head screws, M5 x 0.8 x 100 mm (4x) ⁸

Section 3 Installation

⚠ DANGER



Multiple hazards. Only qualified personnel must conduct the tasks described in this section of the document.

⁶ Input devices are analog inputs from external devices, analog sensors and digital sensors.

⁷ A bracket for panel mounting is available as an optional accessory. Refer to [Replacement parts and accessories](#) on page 53.

⁸ Used for variable diameter pipe mount installations.

3.1 Installation guidelines

⚠ DANGER



Electrical shock hazard. Externally connected equipment must have an applicable country safety standard assessment.

⚠ WARNING



Explosion hazard. This manual is only for installation of the unit in a non-hazardous location. For installation of the unit in hazardous locations, use only the instructions and approved control drawing provided in the hazardous location installation manual.

NOTICE

Do not install the controller in an environment with a caustic atmosphere without a protective enclosure. A caustic atmosphere will cause damage to electronic circuitry and components.

NOTICE

Do not install the controller outdoors in an environment that receives direct sunlight or UV radiation or damage to the controller can occur. Install the optional UV protection screen with sunroof to prevent damage from UV exposure when installed outdoors in direct sunlight.

Note: (Network and Claros version only) Make sure that your IT department has approval for the installation and commissioning of the device. Administrator rights are not necessary. The email address "No-reply@hach.com" sends the setup email and "donotreply@hach.com" sends the system notifications that are necessary for the installation. Add the two email addresses to the safe senders list to make sure to receive mails from these senders. Hach does not send a request to confirm that the sender is not a robot.

- Install the controller in a location where the power disconnect device for the controller is easily operated.
- Attach the controller upright and level on a flat, vertical surface.
- As an alternative, attach the instrument to a panel, vertical pole or horizontal pole.
- Make sure that the device is in a location where there is sufficient clearance around it to make connections and to do maintenance tasks.
- Make sure that there is a minimum of 16 cm (6.30 in.) of clearance for the controller door to open.
- Install the instrument in a location with minimum vibration.
- The optional holder for mobile phones is recommended for all installations.
- The optional sunroof or the optional UV protection screen with sunroof is recommended for all outdoor installations.
- Give protection to computers or other connected equipment that may not have equivalent environmental ratings based on the enclosure rating of the equipment.
- Obey specified ambient ratings on the internal side of panels for panel mount installations.
- Make sure that the maximum power rating is correct for the ambient temperature.

3.2 Mechanical installation

3.2.1 Attach the instrument to a wall

Attach the controller upright and level on a flat, vertical surface. Make sure that the wall mounting is able to hold 4 times the weight of the equipment. Refer to the illustrated steps in [Figure 3](#) and [Product components](#) on page 8 for the necessary mounting hardware.

Figure 3 Wall mounting

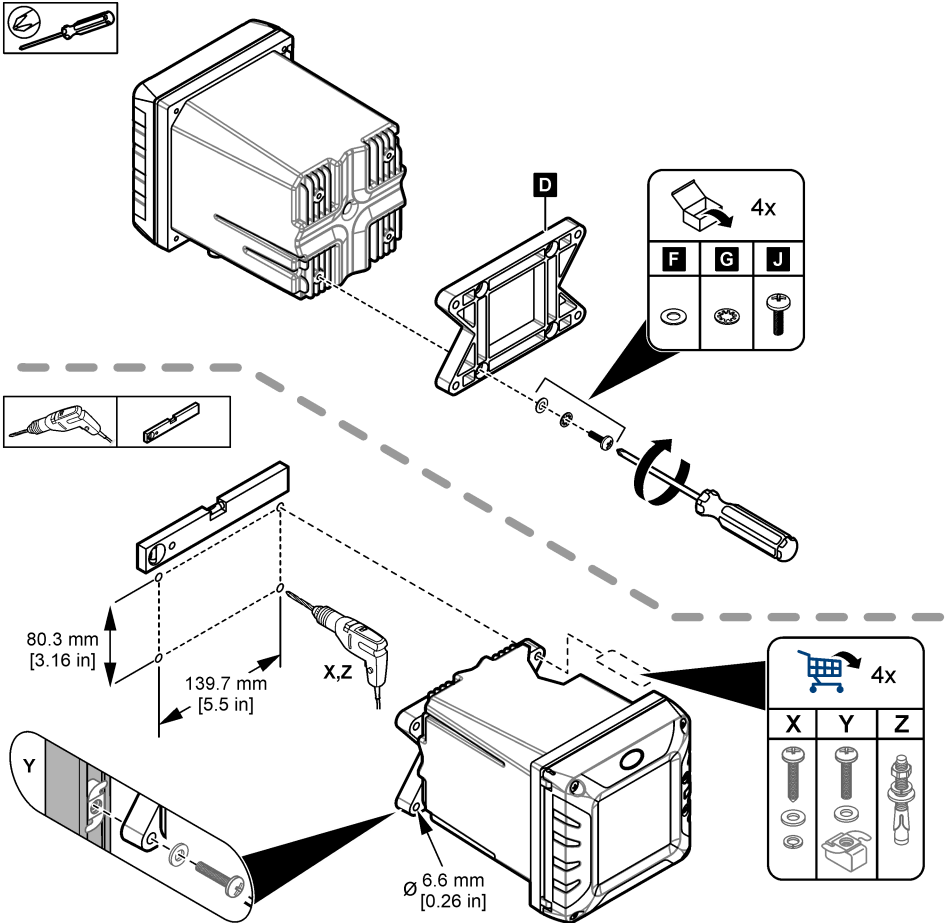

3.2.2 Attach the instrument to a pole

Attach the controller upright to a pole or pipe (horizontal or vertical). Make sure that the pipe diameter is 19 to 65 mm (0.75 to 2.5 in.) Refer to the illustrated steps in [Figure 4](#) and [Product components](#) on page 8 for the necessary mounting hardware.

Figure 4 Pole mounting

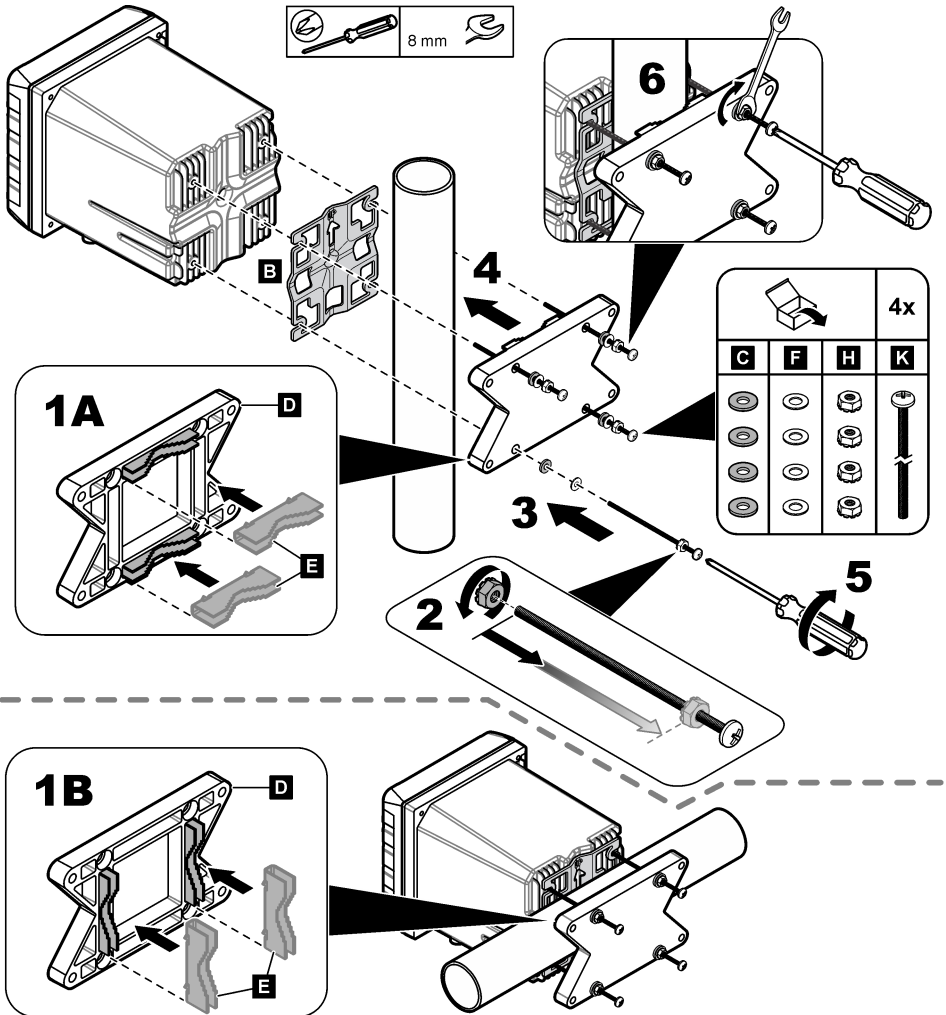

3.2.3 Install the instrument in a panel

A rectangular hole is necessary for panel installation. Use the supplied sealing gasket for panel mount as a template to cut the hole in the panel. Make sure to use the template in the up position to install the controller vertical. Refer to [Figure 5](#).

Note: If using the bracket (optional) for panel mounting, push the controller through the hole in the panel and then slide the bracket over the controller on the back side of the panel. Use the four 15 mm pan head screws (supplied) to attach the bracket to the controller and secure the controller to the panel.

Figure 5 Panel mounting dimensions

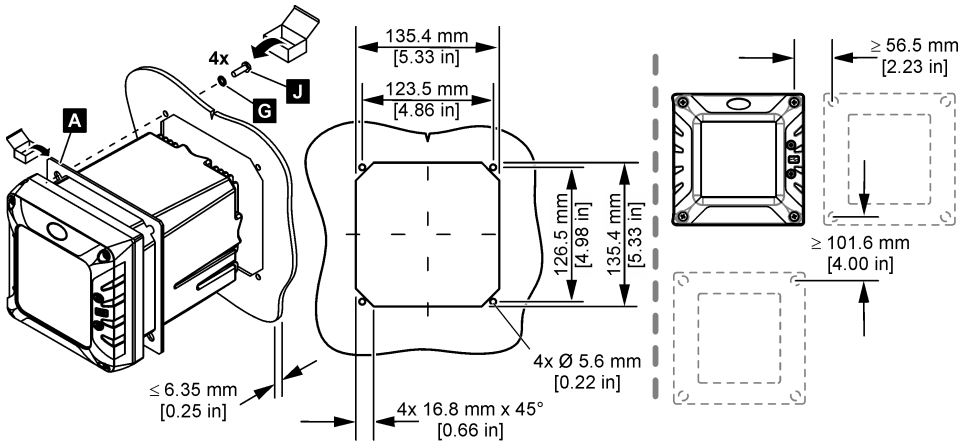

3.3 Electrical installation

3.3.1 Electrical connectors and fittings

Figure 6 shows the electrical connectors and fittings on the instrument. To keep the environmental rating of the enclosure, make sure that there is a plug in the strain relief fittings that are not used and a connector cap on the unused connectors.

Based on the controller configuration, the controller has:

- Ethernet connectors (LAN) to give internet access to the controller through a customer network.
- Ethernet connectors for Industrial Ethernet Protocols: EtherNet/IP or PROFINET.
- Digital SC connectors for sc digital sensors, sc digital gateways and analyzers.

A color code identifies the connectors. The LAN connectors are green with a red dot. The EtherNet/IP or PROFINET connectors are yellow with a red dot. The sc digital sensor connectors are black with a green dot. Refer to Table 1 for the applicable options for each connector and fitting.

Note: The controller is supplied without strain relief fittings installed. The user must supply the necessary strain reliefs. Refer to Replacement parts and accessories on page 53.

Figure 6 Electrical connectors and fittings

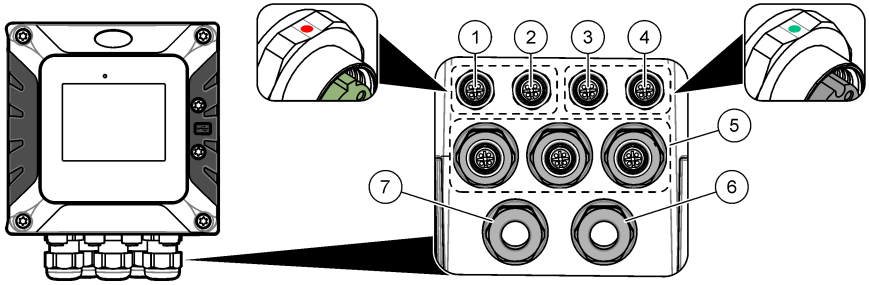

1 Ethernet connector (optional) for LAN port 1 or EtherNet/IP or PROFINET connector	5 Strain relief fitting for USB box and expansion modules: Analog inputs/outputs, Profibus DP
2 Ethernet connector (optional) for LAN port 2 or EtherNet/IP or PROFINET connector	6 Power cord (or conduit hub) ¹⁰
3 Digital SC connector: Channel 1. Optional: Analog sensor connection to sensor module or analog input connection to 4-20 mA input module ⁹	7 Strain relief fitting for high voltage relay
4 Digital SC connector: Channel 2. Optional: Analog sensor connection to sensor module or analog input connection to 4-20 mA input module	

Table 1 Options for each connector and fitting

Device	1 ¹¹	2	Option ¹²	3	4	5	6	7
sc digital sensor, sc digital gateway or analyzer				X	X			
Analog sensor				X	X			
Sensor analog module				X	X			
4-20 mA output						X		
Profibus DP module						X		
Modbus RS232/RS485 module						X		
USB Box						X		
LAN + LAN	●	●	Split / Chaining					
LAN + Modbus TCP	●	●	Split / Chaining					
EtherNet/IP	●	●	IEP only					
LAN + EtherNet/IP	●	●	Mix IEP					
PROFINET	●	●	IEP only					

⁹ To connect an analog sensor or 4-20 mA input to the controller, install the applicable expansion module, if not already installed. Refer to the documentation supplied with the expansion module for additional information.

¹⁰ The power cord is factory-installed based on the controller configuration.

¹¹ A color code identifies the connectors. The LAN connectors are green. The EtherNet/IP or PROFINET connectors are yellow.

¹² Refer to [LAN connection](#) on page 28 for Ethernet port configuration options.

Table 1 Options for each connector and fitting (continued)

Device	1 ¹¹	2	Option ¹²	3	4	5	6	7
LAN + PROFINET	●	●	Mix IEP					
High voltage relay								X
Power supply							X	

3.3.2 Electrostatic discharge (ESD) considerations

NOTICE



Potential Instrument Damage. Delicate internal electronic components can be damaged by static electricity, resulting in degraded performance or eventual failure.

Refer to the steps in this procedure to prevent ESD damage to the instrument:

- Touch an earth-grounded metal surface such as the chassis of an instrument, a metal conduit or pipe to discharge static electricity from the body.
- Avoid excessive movement. Transport static-sensitive components in anti-static containers or packages.
- Wear a wrist strap connected by a wire to earth ground.
- Work in a static-safe area with anti-static floor pads and work bench pads.

3.3.3 Power connections

⚠ DANGER



Multiple hazards. Only qualified personnel must conduct the tasks described in this section of the document.

⚠ DANGER



Electrocution hazard. Always remove power to the instrument before making electrical connections.

If the controller does not have an installed power cord, connect power with conduit or a power cord. Refer to the sections that follow to connect power with conduit or a power cord.

3.3.3.1 Open the controller cover

Open the controller cover to get access to the wiring connections. Refer to [Figure 7](#).

¹¹ A color code identifies the connectors. The LAN connectors are green. The EtherNet/IP or PROFINET connectors are yellow.

¹² Refer to [LAN connection](#) on page 28 for Ethernet port configuration options.

Figure 7 Open the controller

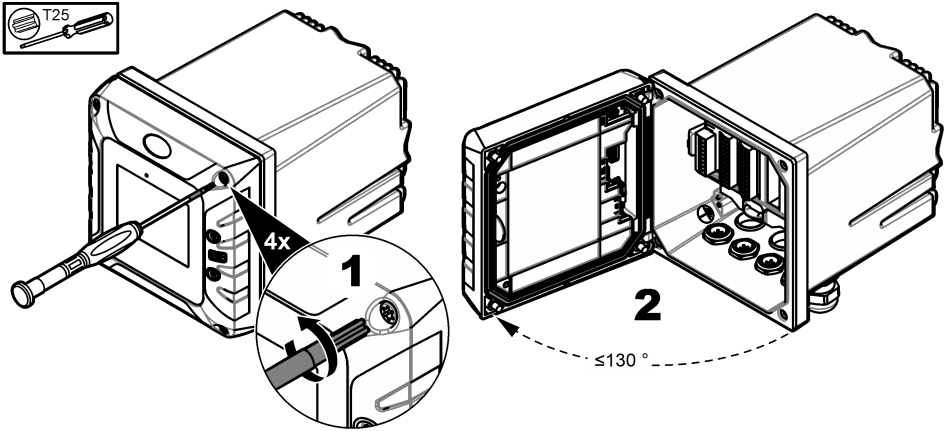

3.3.3.2 Remove the high-voltage barrier

High-voltage wiring for the controller is located behind a high-voltage barrier in the controller enclosure. Do not remove the barrier while power is supplied to the controller. Make sure that the barrier is installed before power is supplied to the controller.

Remove the high-voltage barrier to get access to the high-voltage wiring. Refer to [Figure 8](#).

Figure 8 High-voltage barrier

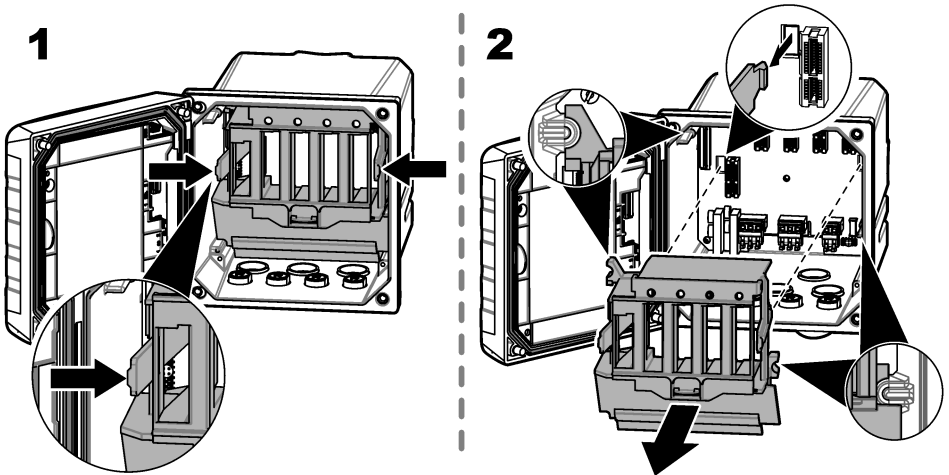

3.3.3.3 Wiring for power

⚠ DANGER



Electrocution hazard. Protective Earth Ground (PE) connection is required.

⚠ DANGER



Electrical shock and fire hazards. Make sure to identify the local disconnect clearly for the conduit installation.

⚠ WARNING



Potential Electrocutation Hazard. If this equipment is used outdoors or in potentially wet locations, a **Ground Fault Interrupt** device must be used for connecting the equipment to its mains power source.

⚠ WARNING



Electrocutation hazard. The local disconnection means must disconnect all the electrical current-carrying conductors. Mains connection must keep supply polarity. The separable plug is the disconnect means for cord connected equipment.

⚠ WARNING



Electrical shock and fire hazards. Make sure that the user-supplied power cord and non-locking plug meet the applicable country code requirements.

⚠ WARNING



Explosion hazard. This manual is only for installation of the unit in a non-hazardous location. For installation of the unit in hazardous locations, use only the instructions and approved control drawing provided in the hazardous location installation manual.

NOTICE

Install the device in a location and position that gives easy access to the disconnect device and its operation.

The controller can be purchased as either a 100-240 VAC powered model or a 18-28 VDC powered model. Follow the appropriate wiring instructions for the purchased model.

Supply power to the instrument with conduit or a power cable. Make sure that a circuit breaker with sufficient current capacity is installed in the power line. The circuit breaker size is based on the wire gauge used for installation.

For installation with conduit:

- Install a local disconnect for the instrument within 3 m (10 ft) of the instrument. Put a label on the disconnect that identifies it as the main disconnect device for the instrument.
- Rated for at least 90 °C (194 °F) and applicable to the installation environment
- For permanent connections use only solid wires. Use cable dimensions between 0.75 to 1.5 mm² (18 to 16 AWG). Flexible wires must have a crimped ferrule or pin type terminal on the end.
- Connect equipment in accordance with local, state or national electrical codes.
- Connect the conduit through a conduit hub that holds the conduit securely and seals the enclosure when tightened.
- If metal conduit is used, make sure that the conduit hub is tightened so that the conduit hub connects the metal conduit to safety ground.
- The DC power source that supplies power to the DC controller must maintain voltage regulation within the specified 18-28 VDC voltage limits. The DC power source must also provide adequate protection against surges and line transients.

For installation with a power cable, make sure that the power cable is:

- Less than 3 m (10 ft) in length
- Rated sufficient for the supply voltage and current.
- Rated for at least 90 °C (194 °F) and applicable to the installation environment

- Not less than 0.75 mm² (18 AWG) with applicable insulation colors for local code requirements. Flexible wires must have a crimped ferrule or pin type terminal on the end.
- A power cable with a three-prong plug (with ground connection) that is applicable to the supply connection
- Connected through a cable gland (strain relief) that holds the power cable securely and seals the enclosure when tightened
- Does not have a locking type device on the plug

3.3.3.4 Connect conduit or a power cord

NOTICE

The manufacturer recommends the use of manufacturer-supplied electrical components, such as power cord, connectors and strain relief fittings.

NOTICE



Make sure that the cable sheath goes through the inner side of the enclosure to keep the environmental rating of the enclosure.

The controller can be wired for line power by hard-wiring in conduit or wiring to a power cord. Regardless of the wire used, the connections are made at the same terminals.

The power cable plug is used to connect and disconnect power to the controller. For installation in conduit, the installed local disconnect is used to connect and disconnect power to the controller.

Refer to [Figure 9](#) and [Table 2](#) or [Table 3](#) to connect conduit or a power cord. Insert each wire into the appropriate terminal until the insulation is seated against the connector with no bare wire exposed. Tug gently after insertion to make sure that there is a secure connection. If necessary, remove the connector from the PCBA for easier wiring of the terminals.

Note: Make sure that all of the cables stay below the cable limit line printed on the PCBA to prevent interferences with the high-voltage barrier. Refer to [Figure 9](#).

Figure 9 Connect conduit or a power cord

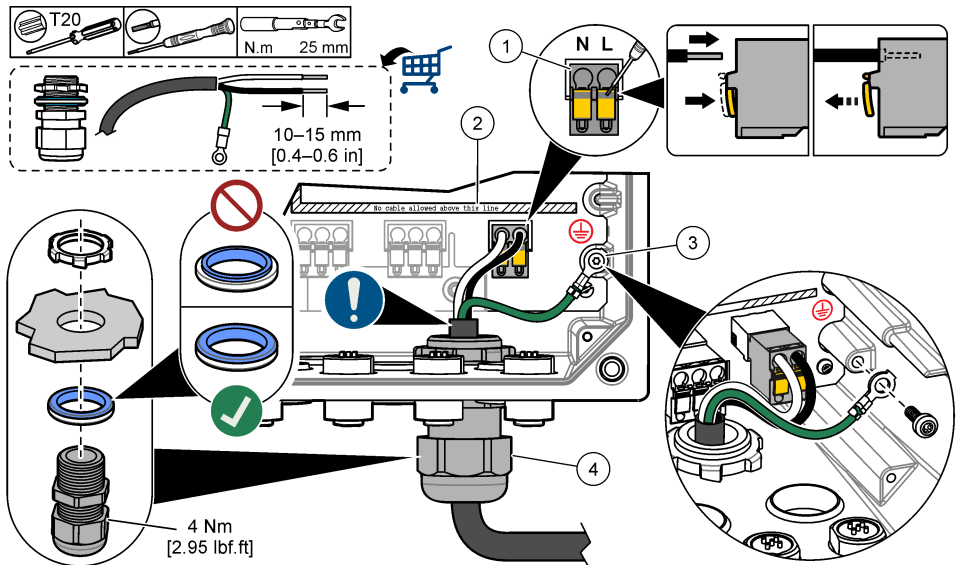

1 AC and DC power terminal	3 Protective earth ground
2 Cables limit: do not put cables above the line.	4 Conduit hub (or strain relief fitting for power cord)

Table 2 Wiring information—AC power



Terminal	Description	Color—North America	Color—EU
L	Hot (Line 1)	Black	Brown
N	Neutral (N)	White	Blue
	Protective earth ground	Green	Green with yellow stripe

Table 3 Wiring information—DC power

Terminal	Description	Color—North America	Color—EU
L	+24 VDC	Red	Red
N	24 VDC return	Black	Black
	Protective earth ground	Green	Green with yellow stripe

3.3.4 Connect the high-voltage relays

⚠ DANGER



Electrocution hazard. Always remove power to the instrument before making electrical connections.

⚠ WARNING



Potential Electrocution Hazard. Power and relay terminals are designed for only single wire termination. Do not use more than one wire in each terminal.

⚠ WARNING



Potential fire hazard. Do not daisy-chain the common relay connections or jumper wire from the mains power connection inside the instrument.

⚠ WARNING



Explosion hazard. This manual is only for installation of the unit in a non-hazardous location. For installation of the unit in hazardous locations, use only the instructions and approved control drawing provided in the hazardous location installation manual.

⚠ CAUTION



Fire hazard. Relay loads must be resistive. Always limit current to the relays with an external fuse or breaker. Obey the relay ratings in the Specifications section.

NOTICE



Make sure that the cable sheath goes through the inner side of the enclosure to keep the environmental rating of the enclosure.

The instrument has two non-powered relays, each with a single-pole change-over contact. For AC controllers, the wiring compartment is not made for voltage connections more than 264 VAC.

The relay terminals are located behind a high-voltage barrier in the controller enclosure. Do not remove the barrier while power is supplied to the relay terminals. Do not supply power to the relay terminals when the barrier is not installed.

Connect each relay to a control device or an alarm device as necessary. Refer to [Figure 10](#) and [Table 4](#) to connect the relays. Refer to [Configure the high voltage relays](#) on page 35 to configure the trigger condition for each relay.

Refer to [Specifications](#) on page 3 for the relay specifications. The relays are isolated from each other and the low-voltage input/output circuitry.

The largest gauge wire the power and relay plugs are rated for 1.5 mm² (16 AWG). The relay terminals accept 0.75 to 1.5 mm² (18 to 16 AWG) wire (as determined by load application). Use wire with an insulation rating of 300 VAC or higher. Insert each wire into the appropriate terminal until the insulation is seated against the connector with no bare wire exposed. Tug gently after insertion to make sure that there is a secure connection. If necessary, remove the connector from the PCBA for easier wiring of the terminals. Flexible wires must have a crimped ferrule or a pin type terminal on the end.

Note: Make sure that all of the cables stay below the cable limit line printed on the PCBA to prevent interferences with the high-voltage barrier.

The current to the relay contacts must be 5 A (resistive only load), 1250 VA 125 W (resistive only load) or less. Make sure to have a second switch available to remove power from the relays locally in case of an emergency or for maintenance.

For AC controllers, use the relays at high voltage. For DC controllers, use the relays at low voltage. Refer to [Specifications](#) on page 3 for the relay specifications. Do not configure a combination of both high and low voltage.

Relay terminal connections to the mains circuit in permanent connection applications must have insulation rated for a minimum of 300 V, 90 °C (194 °F). Terminals connected to the mains circuit with a power cord connection must be double insulated and rated 300 V, 90 °C (194 °F) at both the inner and outer insulation levels.

Note: Put the wires for relays through the strain relief fitting for the high voltage relay. Refer to [Figure 6](#) on page 13.

Figure 10 Connect the relays

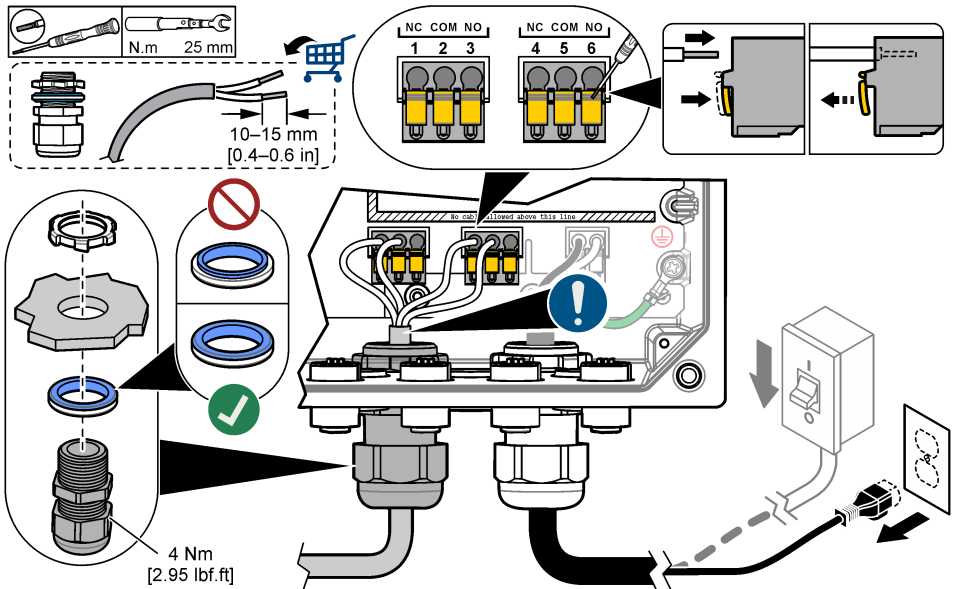

Table 4 Wiring information—relays

Terminal	Description	Terminal	Description
1	Relay 2, NC	4	Relay 1, NC
2	Relay 2, common	5	Relay 1, common
3	Relay 2, NO	6	Relay 1, NO

NC = normally closed; NO = normally open

3.3.5 Install an expansion module

⚠ WARNING



Explosion hazard. This manual is only for installation of the unit in a non-hazardous location. For installation of the unit in hazardous locations, use only the instructions and approved control drawing provided in the hazardous location installation manual.

Expansion modules for analog outputs, analog inputs, analog sensors and Profibus communication are available for the controller. Refer to the documentation supplied with the expansion module for additional information.

3.4 Close the cover

⚠ DANGER



Electrocution hazard. High voltage wiring for the controller is connected behind the high voltage barrier in the controller enclosure. The barrier must remain in place except when installing modules, or when a qualified installation technician is wiring for power, relays or analog and network cards.

NOTICE

Close the controller cover and make sure that the cover screws are tight to keep the environmental rating of the enclosure.

After the power connections are made, install the high-voltage barrier. Make sure that the high-voltage barrier is correctly put on the enclosure guides and fixed to the main PCBA. A click sound is heard when the high-voltage barrier is correctly installed. Make sure that the lower part of the high-voltage barrier (soft rubber lip) is correctly installed and has no deformation. Refer to [Figure 11](#).

Close the controller cover. Tighten the cover screws with 2 Nm (17.70 lbf-in) torque. Refer to [Figure 7](#) on page 15.

Figure 11 Install the high voltage barrier

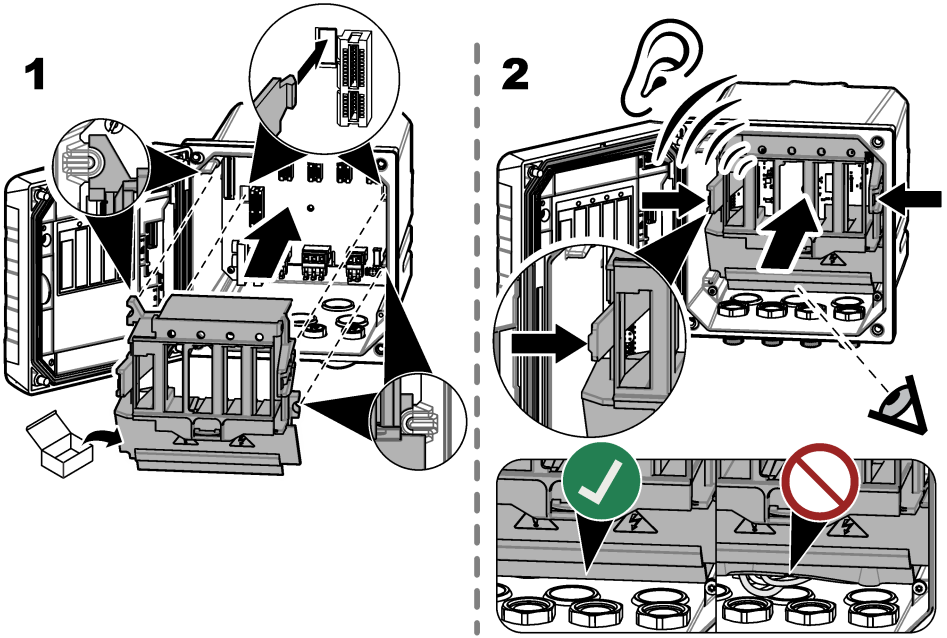

3.5 Connect measurement devices

Connect digital devices (e.g., sensors and analyzers) to the device connectors on the instrument. Refer to [Figure 12](#). Keep the device connector caps for future use.

Make sure that the device cables do not cause a trip hazard and do not have sharp bends.

Figure 12 Connect a device

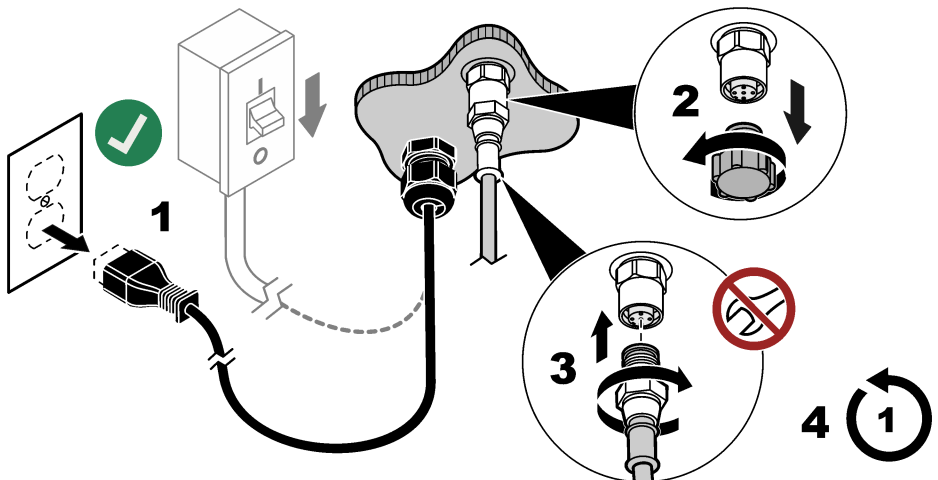

Section 4 User interface and navigation

NOTICE

Do not use writing tips of pens or pencils or other sharp objects to make selections on the screen or damage to the screen will occur.

Figure 13 shows an overview of the main screen. Refer to Table 5 for the descriptions of the icons in the display.

The instrument display is a touchscreen. Only use a clean, dry finger tip to navigate the functions of the touchscreen. To prevent unwanted touches, the screen is automatically lock after a period of inactivity. Touch the screen and swipe up to set the screen back to operation again.

Note: Go to the General configuration menu to disable the Screen lock setting or to set the Waiting time for the inactivity period.

Figure 13 Main screen

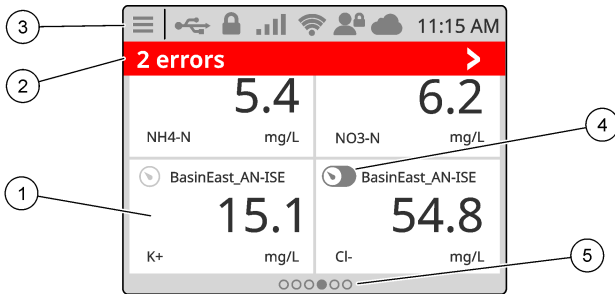



<p>1 Measurement window: shows the device name and a measurement, push on the tile to show the device detail screen</p>	<p>4 Prognosys icon (optional)</p>
<p>2 Diagnostic bar: shows the system messages and alarm conditions, push the bar to see the system errors and warnings. Shows pending tasks and information about the system.</p>	<p>5 Carousel icon: swipe left or right on the screen to show the other screen views.</p>
<p>3 Status bar</p>	

Table 5 Icon descriptions

Icon	Description	Icon	Description
	Push to show the Main menu.		3G/4G signal strength. Shows when a USB box with a cellular modem is connected to the controller.
	Claros connection		USB connection. Shows when a USB flash drive is connected to the controller. Blinks when there is data transmission.
	WiFi connection. Shows when a USB box with a WiFi adapter is connected to the controller.		Remote user. Shows when a remote user is connected to the controller.

Table 5 Icon descriptions (continued)

Icon	Description	Icon	Description
	Screen lock. Shows when the screen is locked. ¹³ Swipe up to unlock the screen.		Push to enter a submenu or go back to the previous menu.
	When in a sub menu, push to go to the main screen.		

Push a measurement window to show the device detail screen. Refer to [Figure 14](#).

Figure 14 Device screen

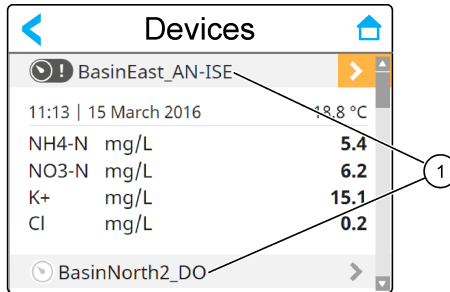

1 Device name

4.1 Measurement window

The main screen shows the measurement windows. Refer to [Figure 15](#). The carousel icon shows at the bottom of the main screen when there are other screen views available.

Each measurement window screen view has one, two or four measurement windows, based on the connected sensors and the parameters of each sensor. If an RTC module is installed on the controller and the license key is activated, the last measurement window screen of the carousel is for the RTC module.

The controller automatically fills the measurement windows to show all of the information for the connected devices. The measurement windows show the data that follows:

- Name, value, parameter and unit of the measurement device and RTC module output, if installed
Note: *Measurement devices are the connected digital sensors, analog sensors connected with analog modules or digital gateways, and external devices that supply 4-20 mA inputs.*
- Sensor errors and warnings. If the background color of the measurement window is amber, there is a warning for the sensor. If the background color of the measurement window is red, there is an error for the sensor. A small right-arrow icon shows when the error or warning is in a different screen view. Push the small right-arrow icon to go to the device notifications screen.
- RTC module warnings. If the background color of the measurement window screen for the RTC module is amber (last measurement window screen of the carousel), there is a warning for the RTC module.
- Prognosis (if available). The Prognosis icon shows when there is no issue or maintenance planned, or if maintenance is due or scheduled. Go to the device detail screen to see more Prognosis information.
- The task in operation (maintenance or calibration task)

¹³ The Screen lock option is enabled by default.

Figure 15 Measurement window screen and device detail screen

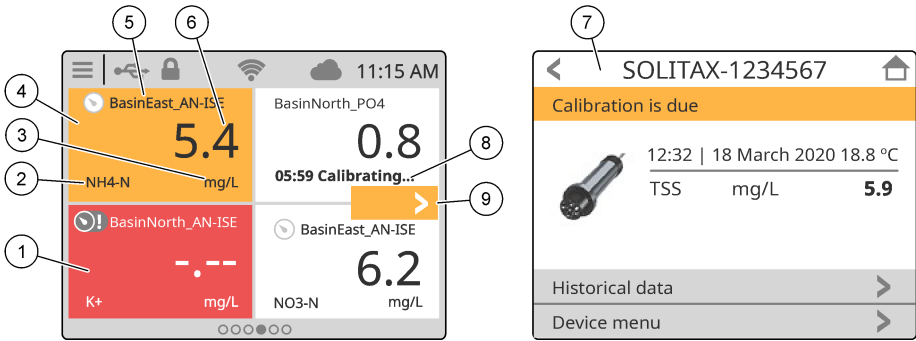

1 Device error	6 Measured value
2 Device parameter	7 Device detail screen
3 Units	8 Task
4 Device warning	9 Error or warning in a different screen view
5 Device name	

4.2 Graph

From the main screen, swipe right until the graph screens show for the connected sensors. Refer to [Figure 16](#). Each graph screen shows the four parameters (maximum) measured by a sensor.

If an RTC module is installed on the controller and the license key is activated, the last screen of the carousel is the graph screen for the RTC module. The graph screen shows the same parameters that show on the measurement window screen for the RTC module.

Figure 16 Graph screen

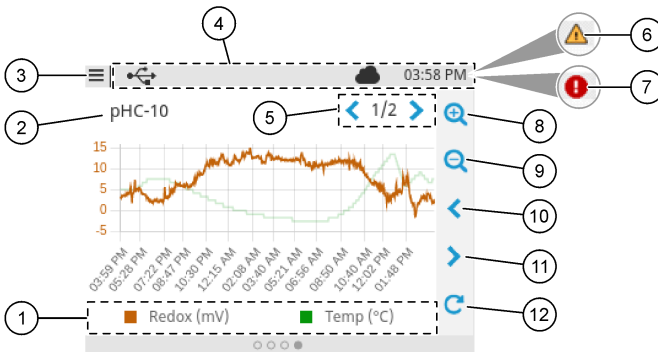

1 Legend: select the parameter shown	7 Error in a different screen view
2 Sensor name (or RTC module)	8 Zoom in
3 Main menu icon	9 Zoom out
4 Status bar	10 Move back in time
5 Number of graph screens (three maximum)	11 Move forward in time
6 Warning in a different screen view	12 Refresh icon

Section 5 Startup

Connect the power cord to an electrical outlet with protective earth ground or set the circuit breaker for the controller to on.

5.1 Menu structure

The menu options available depend on the controller accessories that are installed.

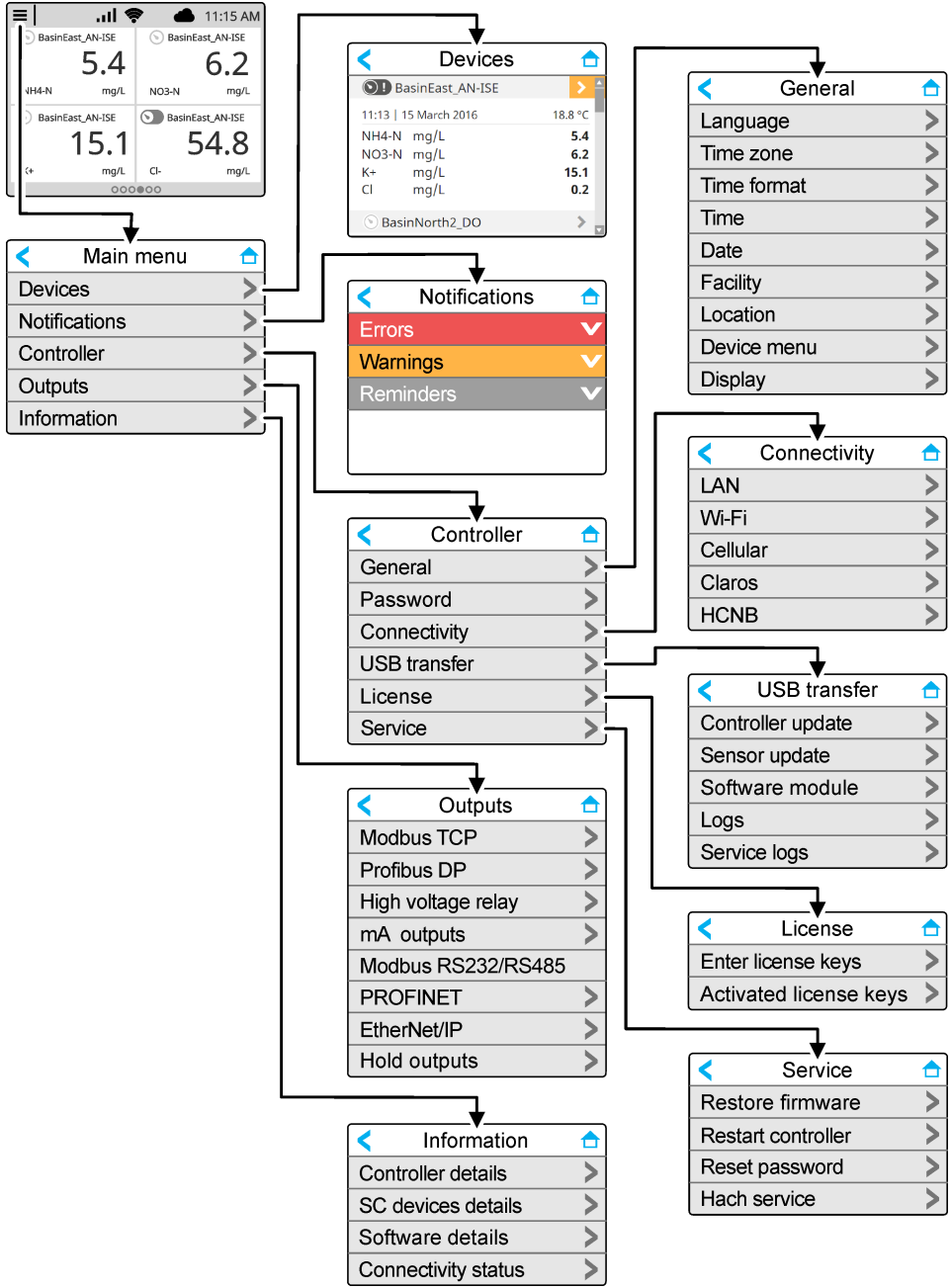

5.2 Enter initial settings

At initial startup, follow the prompts on the display to set up the language, the date, the time and network information. Refer to the expanded user manual on the manufacturer's website for instructions.

Section 6 Operation

6.1 Configure the controller settings

Set the controller language, time, date, facility, location and display options.

1. Push the main menu icon, then select Controller > General.
2. Select and configure each option.

Option	Description
Language	Sets the language that shows on the controller display and in the log files.
Time zone	Sets the time zone. Select the Region and City for the time zone. Note: <i>The Time zone option is not available when the controller is connected to Claros.</i>
Time format	Sets the time format: 12 h (default) or 24 h.
Time	Sets the time. Note: <i>The Time option is not available when the controller is connected to Claros.</i>
Date	Sets the date. Note: <i>The Date option is not available when the controller is connected to Claros.</i>
Facility	Sets the name of the facility (32 characters maximum). Default: not selected
Location	Sets the name of the location (32 characters maximum). Default: controller serial number
Device menu	Shows the controller name and serial number . Change the Name setting as necessary.
Display	Sets the display options: <ul style="list-style-type: none">• Brightness—Sets the brightness of the display. Options: 20%, 40%, 60% (default), 80% or 100%.• Screen lock—When set to on (default), the screen automatically locks after the inactivity period. When the screen is locked, the touchscreen is disabled and there are no active areas in the display. Touch the screen and swipe up to set the screen back to on. Note: <i>The manufacturer strongly recommends not to disable the Screen lock setting. The Screen lock setting prevents unwanted touches on the screen (especially in outdoor installations).</i>• Waiting time—Sets the inactivity period, after which the controller locks the screen. Options: 1, 3, 5, 10 or 15 minutes

6.2 Configure menu access

Set the password protection to on to prevent unwanted changes to specific controller settings and some of the device menus (e.g., sensor and RTC menus).

When password protection is set to on, a prompt to enter the password shows when a menu is protected. After the password is entered, access to the protected menus is available for 30 minutes.

1. To set password protection to on, do the steps that follow:
 - a. Push the main menu icon, then select Controller > Password.
 - b. Select Password protection, then select ON.

The default password is "SC4500". There is only one password for each controller.

2. To change the password, do the steps that follow:
 - a. Push the main menu icon, then select Controller > Password.

- b. Select Change password, then enter the old password.
 - c. Enter the new password. The password must be 4 to 8 characters. The password is case sensitive and can include alphanumeric and special characters.
3. If the password is forgotten, set the password back to the default as follows:
- a. Push the main menu icon, then select Controller > Service.
 - b. Select Reset password. The password is set to "SC4500".
4. To set password protection to off, do the steps that follow:
- a. Push the main menu icon, then select Controller > Password.
 - b. Select Password protection, then enter the password.
 - c. Select OFF.
The password is saved.

6.3 Connect the instrument to a network





Based on instrument configuration, the instrument can connect to a network with internet connectivity for configuration and operation. Based on the version, the controller connects to the internet with a cellular network, WiFi network or a LAN connection.

6.3.1 LAN connection

The controller is supplied with two Ethernet connectors based on the controller configuration. Regardless of the supplied controller, the user must configure the Ethernet ports to the applicable option.

Note: An Ethernet port upgrade may be necessary based on the controller configuration. Refer to the documentation supplied with the upgrade kit.

1. Use a user-supplied Ethernet cable (M12 to RJ45)¹⁴ to connect the controller to a device with internet connection. Refer to [Electrical connectors and fittings](#) on page 12.
2. Push the main menu icon, then select Controller > Connectivity > LAN > Ethernet ports.
3. Enter the settings.

Option	Description
	<p>The controller does not have Ethernet ports or the Ethernet ports are not configured. The controller is supplied with the option None by default.</p> <p>Note: When the controller configuration is set back to the factory settings, all of the LAN connection settings are lost and the Ethernet ports are set back to None.</p>
	<p>The two Ethernet ports are configured for LAN connectivity. When selected, the LAN port configuration setting shows on the LAN menu. The two Ethernet ports have the same port configuration. Select this option to share the internet connection with other controllers (daisy chain topology) or to connect the controller to Claros and HCNB through the Ethernet cable.</p>
	<p>One Ethernet port is configured for LAN connectivity and the other Ethernet port is configured for a separate LAN or Modbus TCP. When selected, the Lan port 1 configuration and Lan port 2 configuration settings show on the LAN menu. The two Ethernet ports have different port configurations. Select the Split option to have different controller connections to Claros and fieldbus (Modbus TCP or HCNB).</p>
	<p>One Ethernet port is configured for LAN connectivity and the other Ethernet port is configured for IEP¹⁵. When selected, the LAN port configuration setting shows on the LAN menu. Select this option to use port 1 for LAN connectivity and port 2 for IEP (compatible with EtherNet/IP or PROFINET star topology).</p>
	<p>The two Ethernet ports are configured for IEP. The two ports are used for EtherNet/IP or PROFINET with chain, ring or star topology.</p>

¹⁴ Refer to [Replacement parts and accessories](#) on page 53.

¹⁵ Based on the controller configuration. Make sure that a PROFINET or EtherNet/IP module is installed in the controller.

4. Push SAVE.
5. When applicable, select LAN port configuration. Enter the settings as follows:
 - a. If the customer network supports Dynamic Host Configuration Protocol (DHCP), set the option to on (default) to get an IP address automatically. The display shows the MAC address of the selected port.
 - b. If the customer network does not support DHCP, set the option to off and complete the settings with IP addresses supplied by the network administrator. Enter the correct settings based on the network topology: IP address, Netmask, Default gateway and DNS address.
 - c. When Chaining is selected, the LAN server option shows on the LAN port configuration menu. Set the LAN server to on to share the internet connection with other controllers through LAN connectivity.
6. Select APPLY.

6.3.2 WiFi network connection

An external USB box WiFi with a WiFi adapter is necessary to connect the controller to a WiFi network. Refer to the documentation supplied with the USB box WiFi for more information about the WiFi installation. Follow all WiFi module manufacturer recommendations and guidance.

If the controller connects to the internet with a WiFi network, do the steps that follow:

1. Push the main menu icon, then select Controller > Connectivity > Wi-Fi.
2. Set the Wi-Fi connectivity button to on. A list of available access points shows.
3. Select Network to set the applicable WiFi access point. If necessary, enter the correct credentials. The WiFi connectivity currently accepts the authentication methods that follows: User name and Wi-Fi password.
 - a. WEP: Not recommended. The WEP authentication method has low security.
 - b. WPA2 Personal / PSK: Standard authentication. Enter the Wi-Fi password to access the network.
 - c. WPA2 Enterprise: Authentication for enterprise networks. Enter the enterprise credentials, User name and Wi-Fi password, to access the network.
4. Select APPLY.

6.3.3 Cellular network connection

Note: Only for Claros connection.

The external USB box cellular is necessary to connect the controller to a mobile network. Refer to the documentation supplied with the USB box cellular for installation instructions.

6.3.3.1 Configuration with Hach Cellular (Telenor) SIM

If the controller connects to the internet with the factory installed SIM card and the default Hach data plan (Telenor), do the steps that follow:

1. Push the main menu icon, then select Controller > Connectivity > Cellular.
2. Set the Cellular connectivity button to on.
3. Select APPLY.

Note: Make sure that the SIM card is not locked. If necessary, use the SIM PIN setting to enter the SIM card PIN.
4. After a maximum of 5 minutes, examine the signal strength that shows on the display. The cloud icon shows a correct connection.

6.3.3.2 Configuration with customer supplied SIM

To change the SIM card and connect the controller to the internet with a cellular network through a customer supplied data plan, do the steps that follow:

1. Install a user-supplied Micro SIM card. Refer to the documentation supplied with the USB box cellular for more information about the cellular network installation.

Note: Follow all the cellular manufacturer recommendations and guidance.

2. Push the main menu icon, then select Controller > Connectivity > Cellular.
3. Make sure that the Cellular connectivity button is set to on.
4. Enter the settings.

Option	Description
Provider	Sets the Provider name (Access Point Name). Select Telenor (NA/Verizon network) for the default settings or Other to set a provider.
APN	Shows the provider name. When Other is selected on the Provider setting, enters the name of the provider.
SIM PIN	SIM card PIN
User name	User name
Password	User password
Internet sharing	Set to on to share the internet connection with other controllers

5. Select APPLY and wait until a confirmation message shows on the display.
6. After a maximum of 5 minutes, examine the signal strength that shows on the display. The cloud icon shows a correct connection.

6.4 Configure the sensors or analog inputs

The controller is supplied with two digital SC connectors based on the controller configuration. Refer to [Figure 6](#) on page 13. Use the digital SC connectors to connect digital sensors to the controller.

To connect an analog sensor or analog input to the controller, remove one of the digital SC connectors and install the applicable expansion module. Refer to the documentation supplied with the expansion module.

Note: To upgrade a one-channel controller to a two-channel controller, install a new digital SC connector or an analog module. Refer to the documentation supplied with the connector upgrade kit or the analog upgrade kit.

The connected devices show on the main screen and in the Devices menu. When the controller connects to a network or Claros, the devices of the network also show. Configure the connected devices as follows:

1. On the main screen, select one measurement window to go to the device detail screen. As an alternative, push the main menu icon, then select Devices. A list of all of the available devices shows.
2. Select one device and select Device menu.
3. If the device is a sensor or instrument, refer to the documentation supplied with the device to configure the device.
4. If the device is a 4-20 mA input module, select mA input and configure the settings that follow:

Option	Description
Calibration	Sets the calibration options for the 4-20 mA input module. <ul style="list-style-type: none">• 1-point value correction• 2-point value correction• Calibration options• Reset to default calibration

Option	Description
Settings	<ul style="list-style-type: none"> • Name—Sets the name that identifies the mA input card. • Edit parameter—Selects the parameter type and unit. • Display range—Sets the value that shows on the display for the 0-20 mA or 4-20 mA. • Signal average—Sets a time in seconds that the controller records the measured input currents. The input current value is the average value of the recorded input currents during the configured time. • Display resolution—Sets the resolution of the values shown. Options: XXXX, XXX.X, XX.XX or X.XXX. • Select scale—Sets the input current range. Options: 0-20 mA or 4-20 mA. • Data log interval—Sets the data log interval. Options: 5 seconds, 30 seconds, 1 minute, 2 minutes, 5 minutes, 10 minutes, 15 minutes, 30 minutes or 60 minutes. • Reset—Sets the configuration back to the factory settings.

Maintenance Shows maintenance tasks for the connected device.

6.5 Connect a USB flash drive (optional)

To do a data download or firmware update, connect a USB flash drive to the front panel in the controller. Refer to [Figure 17](#).

Make sure that the USB flash drive is formatted with one of the options that follow and has a minimum of 350 Mb capacity:

- FAT (12/16)
- FAT32
- exFAT
- NTFS

Do not connect a USB flash drive that has no partitioning table (e.g., Superfloppy)

Note: Not every USB stick is detected, especially the new blue Hach USB sticks do not work sometimes.

After the USB flash drive is removed, close the slot cover and tighten the cover screws. Tighten the cover screws with a maximum torque of 1.4 Nm (12.4 in./lb).

Figure 17 USB flash drive connection

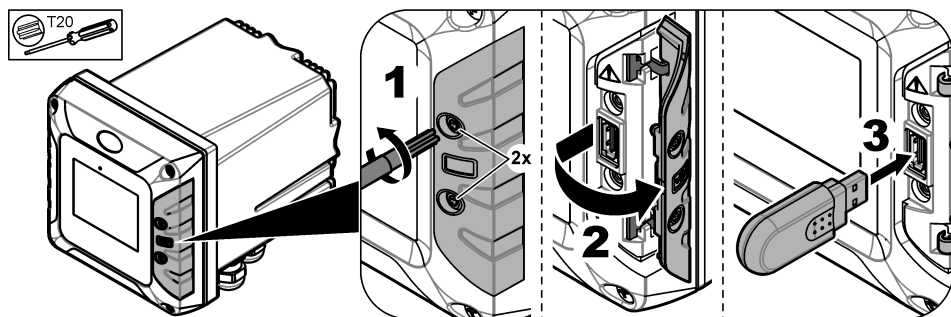

6.5.1 Data download

The controller records in an internal memory the data that follows:

- Approximately 20,000 data points, diagnostics data and an event log of all of the connected sensors and expansion modules
- Diagnostic data

Use a USB flash drive to download data from the controller. As an alternative, use the Claros user interface to download the data from the controller¹⁶.

1. Connect a USB flash drive to the controller. Refer to [Connect a USB flash drive \(optional\)](#) on page 31.
2. Make sure that the USB icon shows on the main screen.
Note: *If the controller does not find a connected USB flash drive or the icon shows grey, refer to [Troubleshooting](#) on page 50.*
3. Push the main menu icon, then select Controller > USB transfer.
4. Select an option.

Option	Description
Logs	Downloads the data and event logs (.csv files) for all of the connected devices. If an RTC module is installed on the controller and the license key is activated, a .csv file that includes the settings export for RTC is downloaded to the USB flash drive.
Service logs	Downloads diagnostic data.

5. If Logs is selected, the controller downloads the data for all of the devices to the "HACH_Logs" folder on the USB flash drive.
6. When the download is complete, remove the USB flash drive.
Note: *The USB icon in the front panel flashes to show data transmission. Wait until the icon stays on to remove the USB flash drive.*
7. Close the USB cover.
8. Open the csv file in Excel as follows:
 - a. Connect the USB flash drive to a PC.
 - b. Open a new, blank workbook in Excel.
 - c. Select the **Data** at the top of the window.
 - d. Select **From Text/CSV**. A window opens.
 - e. Select the csv file that is in the "HACH_Logs" folder on the USB flash drive, then select **Import**. Another window opens.
 - f. In the File Origin box, select **65001: Unicode (UTF-8)**.
 - g. In the Delimiter box, select **Semicolon**, then select **Load**.

6.5.2 Install controller firmware updates

Make sure that the controller has the latest firmware. Use a USB flash drive to update the controller firmware. As an alternative, use the Claros user interface to update the controller firmware¹⁷.

Note: *When a controller firmware update is done, the firmware for the controller, MODBUS TCP and PROGNOSYS are updated, if installed. In addition, the firmware for the 4-20 mA output module, PROFINET module and EtherNet/IP module are updated, if installed.*

1. Visit www.hach.com and download the .zip file for the latest software version.
Note: *To identify the software version installed, push the main menu icon, then select Information > Controller details.*
2. Unpack the .zip file.
3. Copy the .swu file to the root folder of a USB flash drive.
4. Connect the USB flash drive to the controller. Refer to [Connect a USB flash drive \(optional\)](#) on page 31.
5. Make sure that the USB icon shows on the main screen.
Note: *If the controller does not find a connected USB flash drive or the USB icon is grey, refer to [Troubleshooting](#) on page 50.*
6. Push the main menu icon, then select Controller > USB transfer > Controller update.

¹⁶ Based on the controller model. Service logs are not available from Claros user interface.

¹⁷ Based on the controller model

7. Follow the instructions on the screen to install the firmware update.
8. When the update is complete, a message shows on the display. Remove the USB flash drive.
Note: *If there is an error during the firmware update, a message shows on the display. Refer to [Troubleshooting](#) on page 50.*
9. Close the USB cover.

6.5.3 Install sensor firmware updates

Make sure that the connected sensors have the latest firmware. Use a USB flash drive to update the sensor firmware. As an alternative, use the Claros user interface to update the sensor firmware¹⁸.

Note: *When a sensor firmware update is done, the firmware for the digital sensors, 4-20 mA input module, analog sensor module, sc digital gateway and Profibus DP interface are updated, if installed.*

Note: *There is no firmware installed on the analog sensors. The analog sensor firmware is installed on the analog sensor modules and sc digital gateways.*

1. Visit www.hach.com and download the latest software version for the connected SC sensors.
Note: *To identify the software version installed, push the main menu icon, then select Information > SC Devices details.*

2. Copy the file to the root folder of the USB flash drive.

Make sure that the files are in the correct folder. Installation files must be in:

D [USB drive unit]:\HACH\Firmware\[sensor name with MID and IID]\installation file name with code [MID/IID], package number [P] identification file [AC/BC/DD] and version number.

For example:

- D:\HACH\Firmware\LDO2_0_42\LDO2_0_42_P03_AC_V1_24_A.bin

Where,

- MID—Manufacturer ID
- IID—Instrument ID.
- AC—Application code file.
- BC—Boot code file.
- DD—Device driver file.

One or more installation files can be in the installation folder.

3. Connect the USB flash drive to the controller. Refer to [Connect a USB flash drive \(optional\)](#) on page 31.
4. Make sure that the USB icon shows on the main screen.
Note: *If the controller does not find a connected USB flash drive or the USB icon is grey, refer to [Troubleshooting](#) on page 50.*
5. Push the main menu icon, then select Controller > USB transfer > Sensor update.
6. Follow the instructions on the screen to install the firmware update.
7. When the update is complete, a message shows on the display. Remove the USB flash drive.
Note: *If there is an error during the firmware update, a message shows on the display. Refer to [Troubleshooting](#) on page 50.*
8. Close the USB cover.

If the sensor update was successful and the controller does not shows the measurement for the sensor, disconnect and connect the sensor again. If the problem continues, restart the controller.

6.5.4 Restore the controller firmware

If necessary, use the Restore firmware option to go back to the software version installed on the controller before a firmware update.

Note: *The user cannot downgrade the controller software, only go back to the software version installed on the controller before a firmware update.*

¹⁸ Based on the controller model

Note: The user can only restore the controller firmware one time after a firmware update.

1. On the display push the main menu icon, then select Controller > Service > Restore firmware. A confirmation message with the current software version and the restore software version shows.
2. Select Continue.
3. When the procedure is complete, a message with the current controller software version shows on the display.

After a firmware restore, make sure to examine the controller configuration and change it as necessary. A firmware restore procedure can have an effect on the controller configuration, connectivity configuration and other software options (outputs, installed expansion modules, data log).

Note: If the restored software is a very old version, the controller compatibility may be not guaranteed.

6.5.5 Manage a software module

6.5.5.1 Install a software module

To install a software module (e.g., RTC module), refer to the documentation supplied with the software module and the steps that follow:

Note: Only one software module can be installed on the controller at a time.

1. Connect the USB flash drive to the controller. Refer to [Connect a USB flash drive \(optional\)](#) on page 31.
2. Make sure that the USB icon shows on the main screen.
Note: If the controller does not find a connected USB flash drive or the USB icon is grey, refer to [Troubleshooting](#) on page 50.
3. Push the main menu icon, then select Controller > USB transfer > Software module.
4. Select Installation.
5. Follow the instructions on the screen.
6. After the software module is installed, enter the license key that is on the Certificate of License when prompted.

Note: To install the license key at a later time, refer to [Enter license key](#) on page 48. The RTC module cannot be used until the license key is entered.

6.5.5.2 Delete a software module

1. Push the main menu icon, then select Controller > USB transfer > Software module.
2. Select Deletion, then push OK.
3. Select Delete.

Note: The license key is not deleted. The license key stays on the Activated license keys menu.

6.5.5.3 Install a firmware update for an RTC module

A firmware update for an RTC module can only be installed by Hach Service. Please contact Hach Service.

6.6 Configure the outputs

6.6.1 Configure the high voltage relays

The instrument has two non-powered relays, each with a single-pole change-over contact. Make sure that the wiring of the relays is complete before this procedure is started. Refer to [Connect the high-voltage relays](#) on page 18.

1. On the display push the main menu icon, then select Outputs > High voltage relay > System setup.
2. Enter the settings for each relay.

Option	Description
Source	Sets the source device for the relay output. Note: <i>The source device is a sensor connected to the controller or analog inputs (if connected).</i>
Parameter	Sets the parameter for the relay output based on the selected source.
Data view	Sets the value that will be displayed and stored in the data logger as the measured value. Options: Input configuration (default) or Relay contact status.
Function	Sets the function value. Setup options change based on the selected function. <ul style="list-style-type: none">• Alarm—Operates the relays in response to the measured parameter.• Feeder control—Operates the relays in response to the measured parameter.• 2 point control—Operates the relays in response to the measured parameter with two setpoints.• Warning—Operates the relays when the controller finds a SC device warning. Shows the warning and error condition of the selected devices.• Pulse width control—Lets the relays give a pulse width modulated output.• Frequency control—Lets the relays operate in a cyclic manner at a frequency between the minimum pulses for each minute and maximum pulses for each minute.• Timer—Lets the relays to operate at set times independently of the process value.• System error—Shows if a device has an internal error or warning.
Transfer	Sets the transfer value. Options: Relay is energized or Relay is de-energized. (default).
Input value	Shows the process value read from the selected source after the internal formula parser sends the process value (if prompted).
Data logger interval	Sets the interval at which the controller saves the shown value to the data logger. Options: OFF (default), 5 minutes, 10 minutes, 15 minutes, 20 minutes or 30 minutes.

3. Complete the settings based on the Function setting.

Alarm function

Option	Description
Phase	Sets the relay condition when the process value is out of the controlled band. Options: Direct control or Reverse
High alarm	Sets the maximum value of the controlled band in the selected parameter unit.
Low alarm	Sets the minimum value of the controlled band in the selected parameter unit.
High deadband	Sets the hysteresis value used at the upper limit.
Low deadband	Sets the hysteresis value used at the lower limit.
Timer on delay	Sets a delay time for the relay to stay on.
Timer off delay	Sets a delay time for the relay to stay off.
Relay contact status	Displays and logs the status of the relay contact (ON or OFF).

Feeder control function

Option	Description
Phase	Sets the relay condition if the process value is more than the setpoint. Options: Value above the limit or Value below the limit.
Relay setpoint	Set the process value at which the relay condition changes.
Deadband	Sets a hysteresis so the relay will not swing unregulated when the process value converges to the setpoint.
OnMax TIMER	Sets a maximum period of time. During this period the relay stays on when passing the setpoint. When the time expires, the relay changes to OFF regardless of the process value.
Timer on delay	Sets a delay time for the relay to stay on.
Timer off delay	Sets a delay time for the relay to stay off.
Maximum timer expiration	Indicates a period of time (in seconds) for the expiration of the OnMax TIMER and the OffMax TIMER. Relay set to ON, OnMax TIMER set to ON: The time left is displayed before the relay is set to OFF automatically. Relay set to OFF, OffMax TIMER set to ON: The time left is displayed before the relay is set ON again.
Relay contact status	Displays and logs the status of the relay contact (ON or OFF).

2 point control function

Option	Description
Phase	Sets the status of the relay. When the process value enters the band between high and low alarm, the relay condition does not change. Options: Value above the limit or Value below the limit.
High alarm	Sets the upper limit in the unit of the selected parameter of the 2 point control band.
Low alarm	Sets the lower limit in the unit of the selected parameter of the 2 point control band.
Timer on delay	Sets a delay time for the relay to set ON.
Timer off delay	Sets a delay time for the relay to set OFF.
OnMax TIMER	Sets a maximum period of time. During this period the relay is set ON when passing the corresponding limit. As soon as the time expires the relay is set to OFF regardless of the process value.
OffMax TIMER	Sets a maximum period of time (in minutes). During this period the relay is set to OFF when passing the corresponding limit. As soon as the time expires the relay is set ON regardless of the process value.
OnMin TIMER	Sets a minimum period of time. During this period the relay is set ON when passing the corresponding limit. The relay can only be set OFF after the period has expired and after this expiration will be set OFF dependent on the process value.
OffMin TIMER	Sets a minimum period of time. During this period the relay is set to OFF when passing the corresponding limit. The relay can only be set to ON after the period has expired and after this expiration will be set to ON dependent on the process value.
Maximum timer expiration	Shows a period of time (in seconds) for the expiration of the OnMax TIMER and the OffMax TIMER. Options: Relay set to ON, OnMax TIMER set to ON—The time left is displayed before the relay is set to OFF automatically. Relay set to OFF, OffMax TIMER set to ON—The time left is displayed before the relay is set to ON again.

Option	Description
Minimum timer expiration	Shows a period of time (in seconds) for the release of the OnMin TIMER and the OffMin TIMER. Options: Relay set to ON, OnMin TIMER set to ON—Displays the time left before the relay can be set to OFF again. Relay set to OFF, OffMin TIMER set to ON—Displays the time left before the relay can be set ON again.
Relay contact status	Displays and logs the status of the relay contact (ON or OFF).

Warning function

Option	Description
Warning list	Sets the monitoring of the internal warning bits of the selected source. Enabled (default): Monitoring is active. Disabled: Monitoring is not active.
Warning level	<i>Note: The Warning level option is only available when Warning list is set to Enabled.</i> Selects the warning bits that have active monitoring. Enabled (default): Monitoring of the selected warning bit is active. Disabled: Monitoring of the selected warning bit is not active.
Error list	Sets the monitoring of the internal error bits of the selected source. Enabled: Monitoring is active. Disabled (default): Monitoring is not active.
Process event	Sets the monitoring of the internal process event bits of the selected source. Enabled: Monitoring is active. Disabled (default): Monitoring is not active.
Transfer	Sets the status of the relay. Options: Relay is energized or Relays are de-energized. (default) if some or all conditions (this means warning, error or process event bits) are detected in the selected source or if the source is missing.
Timer on delay	Sets a delay time for the relay to set ON.
Timer off delay	Sets a delay time for the relay to set OFF.
Relay contact status	Displays and logs the status of the relay contact (ON or OFF).

Pulse width control function

Option	Description
Mode	Automatic—The relay output works as a PID (Proportional, Integral, Derivative) controller. Manual—The relay output has got an on/off ratio as set in the Manual output.
High alarm	Sets the process value which leads the PWM ratio to 100% (Duty cycle set to Direct control).
Low alarm	Sets the process value which leads the PWM ratio to 0% (Duty cycle set to Direct control).
Manual output	Additionally the on/off ratio can be set (condition: Mode is set to Manual). Note that this ratio cannot exceed a value beyond the values set in the Minimum and Maximum menus.
Phase	Reverses the leading sign of the control deviation for the PID controller.
Minimum	Sets the minimum pulse ratio.
Maximum	Sets the maximum pulse ratio.
Relay setpoint	Sets the process value which is controlled by the PID controller.
Dead zone	The dead zone is a band around the setpoint. In this band the PID controller does not change the PWM on/off ratio output signal. This band is determined as setpoint +/- dead zone. The dead zone stabilizes the PID controlled system which have a tendency to oscillate.

Option	Description
Period time	Sets the cycle duration of the pulse output signal.
Minimum	Sets the minimum PWM ratio.
Maximum	Sets the maximum PWM.
Duty cycle	Sets the status of PWM ratio.
Proportional	<p>Sets the proportional part of the PID controller.</p> <p>The proportional part of the controller generates an output signal which is linearly dependent to the control deviation. The proportional part reacts on any changes at the input but starts to oscillate easily if the value is set high. The proportional part cannot completely compensate disturbances.</p>
Integral	<p>Sets the integration part of the PID controller.</p> <p>The integration part of the controller generates an output signal. The output signal increases linearly if the control deviation is constant. The integration part responds slower than the proportional part and can completely compensate disturbances. The higher the integration part, the slower it responds. If the integration part is set to low, it starts to oscillate.</p>
Derivative	<p>Sets the derivative part of the PID controller.</p> <p>The derivative part of the PID controller generates an output signal which depends on the control deviation changes. The faster the control deviation changes, the higher the output signal gets. The derivative part creates an output signal as long as the control deviation changes. If the control deviation is constant, no signal is created.</p> <p>The derivative part is able to smoothen the oscillation caused by the proportional part. The derivative part allows the proportional part to be set higher and the controller responds faster.</p> <p>If there is no knowledge about the controlled process behavior, it is recommended to set this part to "0", because this part tends to oscillate strongly.</p>

Frequency control function

Option	Description
Mode	<p>Automatic—The relay output works as a PID controller.</p> <p>Manual—The relay output frequency has a cycle duration which is set in the MANUAL OUTPUT menu.</p>
High alarm	Sets the maximum cycle duration which can be set by the PID controller.
Low alarm	Sets the minimum cycle duration which can be set by the PID controller.
Manual output	Indicates the current cycle duration of the output frequency. Additionally the cycle duration can be set (condition: Mode is set to Manual).
Phase	With this menu the leading sign of the control deviation for the PID controller can be reversed.
Relay setpoint	Sets the process value which is controlled by the PID controller.
Dead zone	The dead zone is a band around the setpoint. In this band the PID controller does not change the output frequency. This band is determined as setpoint +/- dead zone. The dead zone stabilizes the PID controlled system which have a tendency to oscillate.
Proportional	<p>Sets the proportional part of the PID controller.</p> <p>The proportional part of the controller generates an output signal which is linearly dependent to the control deviation. The proportional part reacts on any changes at the input but starts to oscillate easily if the value is set to high. The proportional part cannot completely compensate disturbances.</p>

Option	Description
Integral	<p>Sets the integration part of the PID controller.</p> <p>The integration part of the controller generates an output signal. The output signal increases linearly if the control deviation is constant. The integration part responds slower than the proportional part and can completely compensate disturbances. The higher the integration part, the slower it responds. If the integration part is set to low, it starts to oscillate.</p>
Derivative	<p>Sets the derivative part of the PID controller.</p> <p>The derivative part of the PID controller generates an output signal which depends on the control deviation changes. The faster the control deviation changes, the higher the output signal gets. The derivative part creates an output signal as long as the control deviation changes. If the control deviation is constant, no signal is created.</p> <p>The derivative part is able to smoothen the oscillation caused by the proportional part. The derivative part allows the proportional part to be set higher and the controller responds faster.</p> <p>If there is no knowledge about the controlled process behavior, it is recommended to set this part to "0", because this part tends to oscillate strongly.</p>

Timer function

Option	Description
Outputs on hold	<p>Lets the relay put a mark on the sensor configured in the menu SENSOR at the DURATION time. Other expansion modules such as other relay cards or current output cards which access data of this sensor read this 'mark' and go into hold. To go into hold means the accessing module does not read the latest measurement from the marked sensor but works with the last measurement read before the sensor was marked. To activate this function set this menu to Yes. If the sensor will never let other expansion modules go into hold, set this menu to NO.</p> <p>Note: <i>The setting Outputs on hold always adapts to the DURATION time.</i></p>
Relay off-time	Sets the period of time to set OFF the relay in one duty cycle (provided the Duty cycle option is set to Direct control).
Duration unit	Sets the units for the DURATION setting.
DURATION	Sets the period of time for setting ON the relay in one duty cycle (provided the Duty cycle option is set to Direct control).
Timer off delay	Delays the check mark of a probe even if DURATION time has expired. The Timer off delay starts immediately after the DURATION time is expired. This setting only takes effect if Outputs on hold is set to Yes.
Duty cycle	<p>Direct control—Sets the relay ON for the time set in the DURATION menu. Sets the relay OFF for the time set in the Relay off-time menu.</p> <p>Reverse—Sets the relay OFF for the time set in the DURATION menu. Sets the relay ON for the time set in the Relay off-time menu.</p>
Relay contact status	Displays and logs the status of the relay contact (ON or OFF).
Next toggle	Shows the seconds until the relay will toggle.

System error function

Option	Description
Warning list	<p>Enabled—Monitors the internal warning bits of every probe.</p> <p>Disabled—Monitoring is disabled.</p>
Error list	<p>Enabled—Monitors the internal error bits of every probe.</p> <p>Disabled—Monitoring is disabled.</p>
Sensor is missing.	<p>Enabled—Monitors the connection of every connected probe.</p> <p>Disabled—Monitoring is not active.</p>

Option	Description
Timer on delay	Sets a delay for the relay to set ON.
Timer off delay	Sets a delay for the relay to set OFF.
Relay contact status	Displays and saves to the log the status of the relay contact (ON or OFF).

4. Push OK to apply the changes.
5. Push the main menu icon, then select Outputs > High voltage relay > Test/Maintenance. The Test/Maintenance menu lets the user do a test of the internal high voltage relays.
6. Select an option.

Option	Description
Function test	Does a test on the selected relay. Set the Relay 1, Relay 2 or All to ON or OFF for the test. Output mode does a test on the relay output. Options: Hold (default), Active or Transfer.
Relay status	Shows the condition of the relays.

6.6.2 Configure the analog outputs

Make sure that a 4-20 mA output module is installed in the controller. Refer to the documentation supplied with the module. Make sure that all of the necessary electrical connections are complete before the 4-20 mA output is configured.

1. Identify the relation between input current and calculated concentration as follows:
 - Identify what analog output range uses the connected device (0-20 mA or 4-20 mA).
 - Identify the maximum measurement that is equal to the 20 mA on the analog output.
 - Identify the minimum measurement that is equal to the 0 or 4 mA on the analog output.
2. Push the main menu icon, then select Outputs > mA outputs > System setup
The available channels based on the installed expansion modules show.
3. Enter the settings for each channel.

Option	Description
Source	Selects the analog output to configure. For the selected device, select the parameter that set the measurement options.
Parameter	Changes the parameter selected on the source option.
Data view	Sets the measured value that shows on the display and saves to the data log. Options: Input value (default) or Current.
Function	Sets the output function. Setup options change based on the selected function. <ul style="list-style-type: none"> • Linear control—Signal is linearly dependent on the process value. • PID control—Signal works as a PID (Proportional, Integral or Derivative) controller.
Transfer	Sets the transfer value shown on the analog output when the selected source reports an internal error, is disconnected from the system or its output mode is set to Transfer. Default: 10 mA
Current	Shows the calculated output current (in mA). By default, the calculated output mA value is not the same as the real output current (in mA). The real mA output is based on the opposite input resistance and cannot be more than 22 mA.
Data logger interval	Sets the interval at which the shown value is saved to the data logger. Options: OFF (default), 5 minutes, 10 minutes, 15 minutes, 20 minutes or 30 minutes

4. Complete the settings based on the Function setting.

Linear control function

Option	Description
Filter	Sets the record time for the recorded measured values. The average of the recorded values during the record time is shown on the analog output.
Filter unit	Sets the time unit for the Filter setting. Options: seconds (default), minutes, hours or days.
Maximum	Sets the maximum mA value on the analog output. Default: 20 mA
Scale	Sets the output current range. Options: 0-20 mA (default) or 4-20 mA
Low value	Sets the selected source value shown as 0 mA (0-20 mA) or 4 mA (4–20 mA) on the analog output. Default: 0
High value	Sets the selected source value shown as 20 mA on the analog output. Default: 20
Error mode	Sets the analog output on hold or to the transfer value when an internal error occurs. Options: Hold or Transfer If an internal error occurs, the Error mode setting overrides the Set outputs on hold setting. Refer to Hold or release the analog outputs on page 47.

PID control function

Option	Description
Error mode	Sets the analog output on hold or to the transfer value when an internal error occurs. Options: Hold or Transfer If an internal error occurs, the Error mode setting overrides the Set outputs on hold setting. Refer to Hold or release the analog outputs on page 47.
Mode	Sets the output condition when the process value is out of the controlled band. Direct control—The mA output value will decrease as the process variable increases. Reverse—The mA output value will increase as the process variable increases.
Mode	Automatic mode—The output works as a PID controller. The SC4500 Controller looks at the process variable and automatically adjusts the 0–20 mA output. Manual—The PID controller is disabled. The output is fixed as set in Manual output.
Manual output	Sets the output mA value (condition: Mode is set to Manual). The output mA value must be within the values set in the Minimum and Maximum menus.
Minimum	Sets the lower limit for the output current. Default: 0.0 mA
Maximum	Sets an upper limit for the possible output current. Default: 20.0 mA
Relay setpoint	The process value that is wanted. The PID controller tries to adjust to the Relay setpoint value.
Dead zone	The dead zone is a band around the setpoint. In this band, the PID controller does not change the output signal. This band is the setpoint \pm dead zone. The dead zone stabilizes the PID controlled system, which has a tendency to oscillate. It is recommended to set to 0 (default).
Proportional	Sets the proportional part of the PID controller. The proportional part of the controller generates an output signal which is linearly dependent to the control deviation. A higher proportional value reacts quickly on any changes at the input, but starts to oscillate easily if the value is set too high. The proportional part cannot completely compensate disturbances. Example: An error term (difference between the setpoint and process value) is 2 and the proportional gain is 5. The output current value is 10 mA.

Option	Description
Integral	<p>Sets the integration part of the PID controller.</p> <p>The integral part of the controller generates an output signal that increases linearly when the control deviation is constant. The integral part responds slower than the proportional part and can completely compensate disturbances. The higher the integration part, the slower it responds. If the integration part is set to low, it starts to oscillate.</p> <p>For the SC4500 PID implementation, do not set the integration part to 0. The recommended integration part setting is 10 minutes.</p>
Derivative	<p>Sets the derivative part of the PID controller.</p> <p>The derivative part of the PID controller generates an output signal which depends on the control deviation changes. The faster the control deviation changes, the higher the output signal gets. The derivative part creates an output signal as long as the control deviation changes.</p> <p>If there is no knowledge about the controlled process behavior, it is recommended to set this part to 0, because this part tends to oscillate strongly.</p>
Snap shot	Shows the mA input value of the PID controller (process value).
Current	Shows the mA output value of the PID controller.

5. Push OK to apply the changes.
6. Push the main menu icon, then select Outputs > mA outputs > Test/Maintenance.
The Test/Maintenance menu lets the user do a test of the internal plug in the expansion cards.
7. Select an option.

Option	Description
Function test	Does a test on the outputs on the selected module.
Output status	Shows the condition of the outputs on the selected module.

6.6.3 Configure the Modbus RS232/RS485

When the Modbus RS232/RS485 module is installed in the controller, configure the controller for an RS232 connection or RS485 network.

1. Select the main menu icon, then select Outputs > Modbus RS232/RS485.
2. Select an option.

Option	Description
Name	Changes the name of the Modbus module. The name is limited to 16 characters in any combination of letters, numbers, spaces or punctuation.
Modbus address	Sets the Modbus address. Use the arrow keys to select the item to change, then click OK. Select Set address, then enter the address value.
Baud rate	Sets the Baud rate—The rate (bits per second) at which the data is transmitted across the network. All devices on a network must be set to the same Baud rate. The correct setting will depend on the physical layout of the network. Options—9600, 19200 (default), 38.4K, 57.6K or 115.2K
Modbus mode	Sets the Modbus mode. Options: RTU (default) or ASCII

Option	Description
Data order	<p>Little endian (default)—The low-order byte of the number is saved in memory at the lowest address and the high-order byte is saved at the highest address. Example: 4 byte LongInt Byte3, Byte2, Byte1, Byte0</p> <p>Big endian —The high-order byte of the number is saved in memory at the lowest address and the low-order byte is saved at the highest address. Example: LongInt can be stored as: Base Address+0 Byte3 Base Address+1 Byte2 Base Address+2 Byte1 Base Address+3 Byte0</p>
Parity	A byte by byte error check on RS232/RS485 communication. Options: None (default), Even or Odd
Stop bits	Sets the number of stop bits. Options: 1 (default) or 2
Diagnostics/Test	Refer to Diagnostics/Test menu—Modbus RS232/RS485 on page 43.

6.6.3.1 Diagnostics/Test menu—Modbus RS232/RS485

1. Select Diagnostics/Test.

Option	Description
Network timing	<p>The maximum time for the Modbus card to respond to a request from the Modbus Master (external system). Select the following options and use the arrows to enter the values in seconds or use the default setting:</p> <ul style="list-style-type: none"> • Read timeout—The time to read the registers (default: 1 seconds). • Register write timeout—The time to write the registers (default: 3 seconds). • File write timeout—The time to write a block of data to a file (default: 5 seconds). • File preparation timeout—The time to open the file after a request from the Modbus Master is received. The system needs preparation time to read the data from the file or to write the data to the file (default: 6 seconds).
Modbus statistics	Shows the number of successful and failed Modbus requests.
Clear statistics	Deletes the counted messages
Module information	Shows the software version, bootloader version and serial number of the Modbus module.
Reset	Sets the Modbus settings to the factory defaults.

6.6.4 Configure the telegram

The industrial communication protocols usually operates with a cyclic transmission of data between main (master) and secondary (slave) devices on a network. The controller uses Telegram for data transmission. The content of the Modbus TCP telegram is the same as the Profibus telegram, the PROFINET telegram and the EtherNet/IP telegram. Configure the telegram settings as follows:

1. Push the main menu icon, then select Outputs > [output source] > Telegram.
2. Select Add device. A list of available devices show.
3. Select the devices to add to the telegram list and push OK.
4. On the Telegram menu, select one device.
5. Select Add tag. A list of available tags for the selected device shows.
6. Select the tags to add to the device and push OK.

7. Push SAVE.
8. To remove a device from the telegram list, do the steps that follow:
 - a. Go to Outputs > [output source] > Telegram
 - b. Select - Delete device. A list of available devices shows.
 - c. Select the devices to remove and push OK. Confirm to remove the selected devices from the telegram list.

Note: Use the drag and drop function to change the elements on the Telegram list. Push and hold on the element and move the device or tag to the new position. Make sure to update the PLC configuration accordingly after the elements are moved.

6.6.5 Configure the Modbus TCP

Use the Modbus TCP/IP to connect the controller to measurement and control systems that use the TCP/IP protocol for data transmission.

Make sure that all of the necessary electrical connections are complete. Make sure that the Ethernet port in the controller is configured to Modbus TCP. Refer to [LAN connection](#) on page 28.

Note: To upgrade a controller to have Modbus TCP/IP, refer to [Enter license key](#) on page 48.

Note: The recommended poll rate is between 500 milliseconds and 5 seconds.

Configure the controller to use the Modbus TCP communication protocol as follows:

1. Push the main menu icon, then select Outputs > Modbus TCP.
2. Set the Modbus TCP button to on.
3. Select an option.

Option	Description
Modbus TCP	Sets the Modbus TCP to on or off.
IP address	Shows the IP address.
TCP Port	Shows the TCP Port.
Telegram	Manages the Telegram data structure. Select the devices and the device data tags in the Telegram. Refer to Configure the telegram on page 43.
Modbus address	Sets the address (1 to 255) of the Modbus secondary device configured in the Telegram menu.
Virtual modbus slave	Adds virtual secondary devices. The virtual secondary devices are copies of devices configured in the Telegram menu. When set to on, the virtual device is enabled. When set to off (default), the virtual device is disabled.
Data order	Sets the byte sequence for the transmission of floating point values. A floating point value has 4 bytes. The floating point value is only data of the configured slaves. <ul style="list-style-type: none"> • Normal (default)—The pairs are not changed. • Swapped—Changes the first byte pair with the last byte pair.

Note: An incorrect setting in the Data order menu can cause small changes in the floating point values (moved in one register).

Option	Description
Simulation	<p>Simulates two floating point values and errors (or statuses) to replace an instrument. The first floating point value goes through a ramp between limits set in the Minimum and Maximum menus.</p> <ul style="list-style-type: none"> • Simulation—Enables or disables the simulation. Options: on or off. • Period—Sets the time in minutes (0 to 1000) for the first floating point value to go through the full range between Minimum and Maximum settings. • Maximum—The upper limit for the first floating point value. Range: 0.0 to 1000.0 • Minimum—The lower limit for the first floating point value. Range: 0.0 to 1000.0 • Error—Sets the value in the first simulated register. Range: 0 to 65535 • Status—Sets the value in the second simulated register, Range: 0 to 65535 • Toggle—Changes the direction of the simulated ramp application.
Status	Shows information about the data transfer.

4. Push OK.

6.6.6 Configure the Profibus DP

Use Profibus DP (Decentralised Peripherals) to operate sensors and actuators with a centralised controller in production (factory) automation. Make sure that a digital Fieldbus module is installed in the controller. Refer to the documentation supplied with the module. Make sure that all of the necessary electrical connections are complete before the settings are configured.

Configure the Profibus DP settings as follows:

1. Push the main menu icon, then select Outputs > Profibus DP.
2. Set the Profibus DP button to on.
3. Select an option.

Option	Description
Profibus DP	<p>Selects one of the options that follow:</p> <ul style="list-style-type: none"> • Fieldbus address—Changes the slave address. • Data order—Sets the byte sequence for the transmission of floating point values. A floating point value has 4 bytes. Options: Normal—IEEE Float Big Endian (default). The pairs are not changed. The Normal Data order mode can be used with all known Profibus master systems. Swapped—IEEE Float word wise swapped. Changes the first byte pair with the last byte pair.
Telegram	Manages the Telegram data structure. Select the devices and the device data tags in the Telegram. Refer to Configure the telegram on page 43.
Simulation	<p>Simulates two floating point values and errors (or statuses) to replace an instrument. The first floating point value goes through a ramp between limits set in the Minimum and Maximum menus.</p> <ul style="list-style-type: none"> • Simulation—Enables or disables the simulation. • Period—Sets the time in minutes (0 to 65535) for the first floating point value to go through the full range between Minimum and Maximum settings. • Maximum—The upper limit for the first floating point value. Range: $-3.402823E+38$ to $3.402823E+38$ • Minimum—The lower limit for the first floating point value. Range: $-3.402823E+38$ to $3.402823E+38$ • Error—Sets the value in the first simulated register. Range: 0 to 65535 • Status—Sets the value in the second simulated register, Range: 0 to 65535 • Toggle—Changes the direction of the simulated ramp application.
Version	Shows the software version of the Profibus network module.
Location	Sets the location name to identify the Profibus network module. Default: network module serial number

Option	Description
Status	Shows the condition of the Profibus network module. <ul style="list-style-type: none"> Status—Options: Please wait—Shows until the network module finds all of the configured secondary devices or shows when the module configuration is new and looks for devices connections. Ready—Shows when the network module is prepared to send data to the Profibus. Online—Shows when the network module is connected to the PLC and cyclic data is sent. Note: <i>Based on the number of devices, the duration of a new or initial telegram configuration can take some minutes.</i> PLC configuration error—Shows when the network card has received a wrong configuration of a PLC (programmable logic controller), such as write to a read only variable.
Input from PLC	<ul style="list-style-type: none"> Datalog Interval—Sets the data log interval. Unit—For each text parameter (1 to 8), select a Parameter and Unit that will show on the tag that will send the PLC as follows: <ol style="list-style-type: none"> Select Parameter and Unit. Select Search parameter and search for related parameters. For example, enter DO to find all of the parameters related to dissolved oxygen. A message shows the quantity of parameters found. Push OK. Select Parameter to go to the list of parameters found. Select one parameter, then push OK. Select Unit to select one unit based on the selected parameter. Apply changes to save the configuration. Do the steps again for the other text parameters or go back to the Profibus DP menu.
Reset configuration	Sets the configuration back to the factory settings.

4. Push OK.

6.6.7 Configure the EtherNet/IP

The controller can connect to a PLC through Industrial Ethernet Protocol including a EtherNet/IP solution. Ring and bus topologies are available.

Pre-requisites:

1. Make sure that a EtherNet/IP module is installed in the controller. Refer to the documentation supplied with the module.
2. Make sure that all of the necessary electrical connections are complete before the module is configured.
3. Make sure to set the Ethernet ports option to IEP only or Mix IEP. Refer to [LAN connection](#) on page 28.

For configuration information, refer to the EtherNet/IP documentation, available on the manufacturer's website (DOC273.52.90750 and DOC343.52.90752).

6.6.8 Configure the PROFINET

The controller can connect to a PLC through the Industrial Ethernet Protocol, which includes a PROFINET solution. Ring and bus topologies are available.

Pre-requisites:

1. Make sure that a PROFINET module is installed in the controller. Refer to the documentation supplied with the module.
2. Make sure that all of the necessary electrical connections are complete before the module is configured.
3. Make sure to set the Ethernet ports option to IEP only or Mix IEP. Refer to [LAN connection](#) on page 28.

For configuration information, refer to the PROFINET documentation, available on the manufacturer's website (DOC273.52.90750 and DOC343.52.90752). To set the analog output for one or more channels (devices) on hold or to the transfer value, refer to [Hold or release the analog outputs](#) on page 47.

6.6.9 Hold or release the analog outputs

Set the output mode of the analog outputs to Hold or Transfer, or release the analog outputs.

1. Push the main menu icon, then select Information > Hold outputs.
2. Select an option.

Option	Description
Set outputs on hold	<p>Sets the analog outputs on hold for the selected channels. When the analog outputs are on hold, the measurement shown on the analog outputs do not change.</p> <p>Set the Mode of the analog outputs to Hold last measurement value or show the Transfer measurement value.</p> <p>Refer to the Transfer setting in Configure the analog outputs on page 40 to set the transfer measurement value.</p> <p>Note: <i>If an internal error occurs, the Error mode setting overrides the output mode selected. Refer to Configure the analog outputs on page 40 to change the Error mode setting.</i></p>
Release all outputs	<p>Releases all of the analog outputs.</p>

6.7 Hach Controller Network Bus configuration

The Hach Controller Network Bus (HCNB) is a network used to share the connection to the PLC embedded by one controller and configure the system with remote sensors connected to other controllers (SC4500, SC4200c, SC1500 or RTC). The HCNB is applicable to Claros and non-Claros controllers, but all of the controllers must be connected to the HCNB.

Make sure that the controller connects to the network through LAN or WiFi. Refer to [LAN connection](#) on page 28 and [WiFi network connection](#) on page 29. To configure the controller to use the HCNB, do the steps that follow:

1. Push the main menu icon, then select Controller > Connectivity > HCNB.
2. Set the HCNB button to on. The controller automatically sets the default parameters for Port, Interface and Auto detection.

Note: *When the HCNB option is enabled, the controllers in the same network are automatically found.*
3. Push APPLY. The controller is set to off and then on again, and HCNB is enabled.

For additional information, refer to the SC4500 network documentation, available on the manufacturer's website.

6.8 Prognosis diagnostic system

The Prognosis diagnostic system shows the status of maintenance tasks and gives the status of the instrument condition. The measure indicator monitors the instrument components and uses the information to show the condition of the instrument. The service indicator counts the number of days until the maintenance tasks must be completed.

If the controller has Prognosis enabled, the Prognosis icon shows on the measurement window in the main view. The device screen shows the device measurement quality with a percentage of the Health indication. In addition, the device screen shows the maintenance tasks with the number of days that remain until the tasks must be completed. Refer to the sensor documentation for additional information.

To upgrade a controller to have the Prognosis diagnostic system, refer to [Enter license key](#) on page 48.

6.9 Claros

Based on the controller configuration, the controller can connect to Claros for data transmission and device configuration.

Configure Claros on the controller as follows:

1. Make sure that the controller is connected to the internet with a cellular network, WiFi network or through LAN. Refer to [Connect the instrument to a network](#) on page 28.
Note: Push the main menu icon, then select Information > Network status to examine the network connection of the controller.
2. Push the main menu icon, then select Controller > Connectivity > Claros.
3. Make sure that the Claros button is set to on.
4. Connect to your Claros account and provision the controller. Follow the steps in the Claros interface.
Note: Contact Hach to learn more about Claros or to get a Claros account.
Note: Sensor measurements may go out of view until the controller is successfully provisioned to Claros. If the controller is disconnected from Claros, make sure to set the Claros button to off to show sensor measurements on the display.

When the Claros configuration is complete, the Cloud icon shows on the status bar of the main screen.

6.10 Enter license key

Enter a license key to upgrade the controller software with new functions (e.g., Prognosys, Modbus TCP) and to add software modules such as an RTC module.

Enter the license key as follows:

1. Push the main menu icon, then select Controller > License.
2. Select one option:

Option	Description
Enter license keys	Enters a license key to upgrade the controller.
Activated license keys	Shows a list with the activated software on the controller.

3. Enter the license key. Push OK.
Note: Contact the manufacturer or a sales representative to get a license key.
A message shows if the upgrade is correct.

6.11 Show the instrument information

Shows information about the controller and connected SC sensors. Shows the controller connection status.

1. Push the main menu icon, then select **Information**.
2. Select an option.

Option	Description
Controller details	Shows the controller serial number, installed software package, the user-defined facility and location of the controller.
SC Devices details	Shows the data for the connected devices (e.g., 4–20 mA inputs, relays, digital sensors, digital analyzers and expansion modules). Shows the device type, serial number, firmware and Claros status.

Option	Description
Software details	Shows the type, serial number, firmware version of the software module (e.g., RTC module) installed on the controller. If Claros is set to on, the Claros status shows.
Connectivity status	Shows the network condition based on the controller connectivity. <ul style="list-style-type: none"> • Claros—Shows if the controller is successfully connected to the internet and Claros. • Wi-Fi—Shows if the controller is successfully connected to internet using Wi-Fi connectivity. If there is an error, shows possible causes and solutions. • Cellular—Shows if the controller is successfully connected to internet using Cellular connectivity. If there is an error, shows possible causes and solutions. • LAN—Shows the connection condition and the MAC and IP address of each configured Ethernet port.

Section 7 Maintenance

NOTICE

Do not disassemble the instrument for maintenance. If the internal components must be cleaned or repaired, contact the manufacturer.

7.1 Clean the instrument

Clean the exterior of the instrument with a moist cloth and a mild soap solution and then wipe the instrument dry as necessary.

Note: The manufacturer recommends that the screen is locked during cleaning, or when a waterjet is used near the controller.

7.2 Unlock the controller cover

Some outdoor conditions can cause a blockage in the controller cover. If necessary, use a flat screwdriver to push at the hinge groove and unlock the controller cover. Refer to [Figure 18](#).

Make sure to install the high-voltage barrier and close the controller cover after maintenance is complete. Refer to [Close the cover](#) on page 20.

Figure 18 Unlock the controller cover

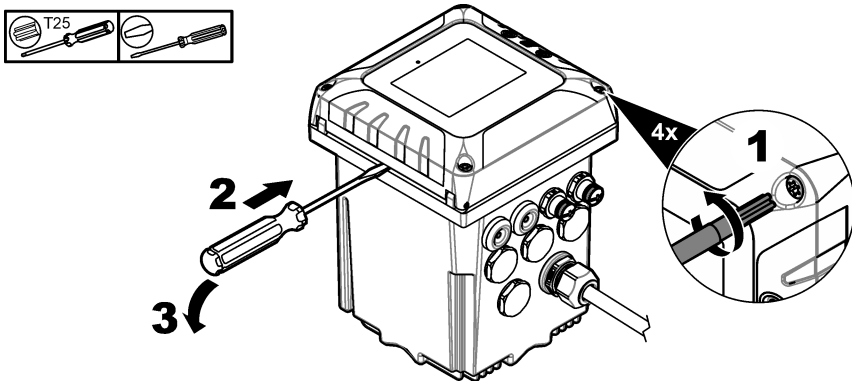

7.3 Fuse replacement

Fuses are not user-serviceable items. The need for fuse replacement in controllers indicates severe technical failure and is therefore considered to be a service activity. If a blown fuse is suspected, contact Technical Support.

7.4 Battery replacement

The lithium ion backup battery is not user replaceable. Contact technical support for replacement.

Section 8 Troubleshooting

Problem	Possible cause	Solution
Controller will not power up, or powers up intermittently.	Power is not supplied to the controller.	Make sure that the power cable is connected to the controller. Make sure that the power connections are properly terminated in the controller. Make sure the power strip, line power, wall plug are all properly plugged in. Make sure that the controller is connected to the correct power source: 100-240 VAC for AC controllers and 18-28 VDC for DC controllers. Contact technical support.
The controller shows a sensor warning or error.	The sensor reported a warning message.	Refer to the sensor warning description shown in the device detail screen and to the sensor user manual.
	The measurement is not correct because of a sensor error.	Refer to the sensor warning description shown in the device detail screen and to the sensor user manual.
"Unknown device connected" message	The rotary switch of the sensor module is not set correctly.	Set the rotary switch of the sensor module to the correct position for the sensor type. Refer to the sensor module documentation.

Problem	Possible cause	Solution
Sensor is not recognized.	Too many devices installed	Make sure that only two input devices are connected to the controller. If more than two input devices are connected, the controller will see only two of the devices. Input devices are analog inputs from external devices, analog sensors, digital sensors or analyzers. If a digital sensor and two analog modules are connected, only the two analog modules are seen by the controller. Analog modules are 4–20 mA input modules and sensor modules.
	Two devices are connected to the same channel	Make sure that the analog module and the digital sensor are not connected to the same channel. Refer to items 3 and 4 in Figure 6 on page 13. The analog module slots are internally connected to the channel (Slot 3 = Channel 1, Slot 4 = Channel 2). If a digital sensor and an analog module are connected to the same channel only the analog module is seen by the controller. Analog modules are analog input modules and sensor modules.
	Extension cable damage	If applicable, remove extension cables from the sensors and directly connect the sensor to the controller. Connect the sensor to a different controller to identify if there is sensor damage.
	The communication between the sensor and the controller is defective.	Examine the sensor and the sensor cable for damage. If damage is found, contact technical support.
		If no damage is found, disconnect the sensor, wait 15 seconds, then connect the sensor again. Contact technical support if the communication failure shows again.
	The sensor version is not applicable to the controller.	Make sure that the sensor is applicable to the controller. Contact technical support.
The sensor firmware is not applicable to the controller.	Make sure to update the sensor firmware to the latest available version. Refer to Install controller firmware updates on page 32.	
No relay activation	Incorrect relay connection or configuration	Make sure that the relay connections are secure. Make sure that the relay wiring is correct. Make sure that the relay configuration is correct. The relay should energize and de-energize as selected.
The controller does not recognize the USB flash drive.	Non-compatible USB flash drive	Make sure that the USB flash drive is formatted with FAT32 and has a minimum of 350 Mb capacity. The USB port on the controller is compatible with USB 2.0 devices. Note: <i>USB 3.0 devices are also compatible but the device will have a USB 2.0 transfer speed.</i> Try again with a more recent USB flash drive.
Firmware update failed	The USB flash drive was removed during the update or the update file is corrupted.	Remove the USB flash drive and do the firmware update process again. Download a new firmware update file. Contact technical support if the error shows again.

Problem	Possible cause	Solution
Restore firmware failed	Error code 1: Generic error	Try to restore the firmware again. Contact technical support if the error shows again.
	Error code 2, 3, 5 or 6: The previous update was not successful or there is no previous firmware version. The restore firmware is not compatible. The restore firmware is corrupted or defective.	A firmware restore is not possible. Contact technical support.
	Error code 4: The firmware version is already a restored version.	It is only possible go back to the firmware version installed on the controller before the firmware update. The user can not downgrade the controller firmware.
Download failed: A problem occurred while downloading the log files.	USB flash drive issue	Push Yes to try again. If the error shows again, restart the controller and try the download again. Contact technical support if the error shows again.
Module is not recognized.	Module connection issue	Make sure that the expansion module is correctly installed. Refer to the expansion module documentation. If possible, remove the expansion module and install the expansion module into a different slot. Contact technical support.
There are navigation issues on the controller touchscreen.	There is dirt on the touchscreen.	Clean the screen. The manufacturer recommends a regular cleaning of the touchscreen. Note: Make sure that the screen is locked during cleaning to prevent unwanted touches. Refer to Configure the controller settings on page 27.
The Claros connection icon shows crossed out.	No access to Claros, but access to the internet	If the controller is connected for the first time to Claros, make sure that the controller is provisioned in Claros. If the controller was connected to Claros before, set the controller to off and then on again. Examine the controller connectivity. Refer to Show the instrument information on page 48. Contact technical support if the error shows again.
Time synchronization OFF	The controller cannot access the NPT internet service to get the clock automatically synchronized.	Make sure that there are no restrictions to external access in the controller network. Contact your IT department and make sure that the network has access to the internet NTP service. If the controller does not connect to Claros, go to Controller > Connectivity > Claros and disable Claros. Then, add the date and time manually in the controller settings.
	The controller has Claros enabled but there is no access to internet.	Make sure that the controller connects to the internet. Examine the controller connectivity.
NTP service unreachable	The controller cannot access the NPT internet service to connect to Claros.	Make sure that there are no restrictions to external access in the controller network. Contact your IT department and make sure that the network has access to the internet NTP service. Make sure that UDP port 123 is open and Pool.ntp.org address is approved in the network.

Problem	Possible cause	Solution
The Claros icon stays off. The Claros connection icon shows crossed out.	No access to internet	Cellular internet access: <ul style="list-style-type: none"> Examine the controller connectivity. Refer to Show the instrument information on page 48. Examine the cellular signal strength. Move the USB box to a location with higher signal strength. Examine the SIM card settings (provider, APN etc.). Make sure that prepaid SIM card has credit. Make sure that the SIM card data volume is not exceeded.
		Wi-Fi internet access: <ul style="list-style-type: none"> Examine the controller connectivity. Refer to Show the instrument information on page 48. Examine the Wi-Fi signal strength. Move the USB box to a location with higher signal strength. Use another device to make sure that WiFi access point is enabled. Make sure that the correct credentials were used in the WiFi configuration. Refer to WiFi network connection on page 29.
		LAN internet access: <ul style="list-style-type: none"> Examine the controller connectivity. Refer to Show the instrument information on page 48.
	No access to Claros	Make sure that the sensors and devices are correctly connected and provisioned in Claros.

Section 9 Replacement parts and accessories

⚠ WARNING



Personal injury hazard. Use of non-approved parts may cause personal injury, damage to the instrument or equipment malfunction. The replacement parts in this section are approved by the manufacturer.

Note: Product and Article numbers may vary for some selling regions. Contact the appropriate distributor or refer to the company website for contact information.

Replacement parts

Description	Item number
M12/RJ45 connector kit	LXZ524.99.00009
M12/M12 connector kit	LXZ524.99.00010
Ethernet cable, M12 to M12, 10 m (32.8 ft)	LXZ524.99.00011
Ethernet cable, M12 to RJ45, 5 m (16.4 ft)	LXZ524.99.00012
USB to Ethernet adapter	LZ472-01
Panel mount bracket	8001316
Controller installation kit	8806200
Mounting hardware kit (screws only)	9177800
Mounting bracket inserts	9177900

Description	Item number
SC4500 front door assembly, includes: Touchscreen, USB cover and screws	LXZ525.99.00010
SC4500 USB cover replacement, includes screws	LXZ525.99.00012
SC4500 front door screws (2x)	LXZ525.99.00023
M20 cable gland kit	LXZ525.99.00024
M16 cable gland kit	LXZ525.99.00022
Hole plug kit, includes: M16 hole plugs (4x) and M20 hole plugs (3x)	LXZ525.99.00021
M20 hole plug	LXZ525.99.00008

Expansion modules

Description	Item number
SC4500 mA output module, five outputs, US and Europe	LXZ525.99.D0002
SC4500 mA output module, five outputs, all countries but US and Europe	LXZ525.99.D4002
SC4500 Modbus RS module, US and Europe	LXZ525.99.D0008
SC4500 Modbus RS module, all countries but US and Europe	LXZ525.99.D4008
SC4500 Profibus DP network module	LXZ524.99.00007
SC4500 PROFINET upgrade kit, US and Europe	LXZ525.99.C0001
SC4500 PROFINET upgrade kit, all countries but US and Europe	LXZ525.99.C4001
SC4500 EtherNet/IP upgrade kit, US and Europe	LXZ525.99.C0002
SC4500 EtherNet/IP upgrade kit, all countries but US and Europe	LXZ525.99.C4002
SC4500 Modbus TCP upgrade kit with license	LXZ525.99.C0005
SC4500 connector upgrade kit, includes cable nut and cap	LXZ525.99.00001
SC4500 mA input module	LXZ524.97.00042 LXZ524.98.00042
SC4500 pH/ORP module, US and Europe	LXZ525.99.D0003
SC4500 pH/ORP module, all countries but US and Europe	LXZ525.99.D4003
SC4500 conductivity module, US and Europe	LXZ525.99.D0004
SC4500 conductivity module, all countries but US and Europe	LXZ525.99.D4004
SC4500 ultrapure pH/ORP module, US and Europe	LXZ525.99.D0006
SC4500 ultrapure pH/ORP module, all countries but US and Europe	LXZ525.99.D4006
SC4500 ultrapure conductivity module, US and Europe	LXZ525.99.D0007
SC4500 ultrapure conductivity module, all countries but US and Europe	LXZ525.99.D4007
SC4500 ultrapure amperometry module	LXZ525.99.D0009

Accessories

Description	Item number
Power box with power connection cable for AMTAX sc and PHOSPHAX sc	LQV155.99.00012
Power box without power connection cable for AMTAX sc and PHOSPHAX sc	LQV155.99.00002
SC4500 External USB box WiFi (for EU)	LXZ525.99.A0001
SC4500 External USB box WiFi (for North America)	LXZ525.99.A0002
SC4500 External USB box Cellular (for EU)	LXZ525.99.A0011
SC4500 External USB box Cellular (for North America)	LXZ525.99.A0012
SC4500 Wi-Fi USB Box (for Asia and Americas)	LXZ525.99.00018
SC4500 M12/RJ45 cable for USB box, includes nut and cap	LXZ525.99.00004
SC4500 USB flash drive	LXZ525.99.00017
UV protection screen	LXZ524.99.00004
UV protection screen including sunroof	LXZ524.99.00005
Holder for mobiles	LXZ524.99.00013
Sunroof visor	LXZ524.99.00033
Sunroof	LXZ524.99.00037
Mounting hardware for sunroof	LXZ524.99.00036

Software modules¹⁹

Description	Item number
SC4500 RTC-N/DN module upgrade	LXZ520.99.K0101
SC4500 RTC-N/DN(DO) module upgrade	LXZ520.99.K3101
SC4500 N/DN upgrade to 1 VSD DO control	LXZ520.99.M3101
SC4500 RTC-N/DN(ORP) module upgrade	LXZ520.99.L0101
SC4500 RTC-N/DN(ORP)(DO) module upgrade	LXZ520.99.L3101
SC4500 RTC-P module upgrade	LXZ515.99.K1010
SC4500 RTC-SP module upgrade	LXZ517.99.K0101
SC4500 RTC-DAF module upgrade	LXZ517.99.L0101

Appendix A Telegram tag list

Legend:

- **Device**—Shows all of the SC devices that can be selected for the SC4500 controller as source (for mA output or High voltage relay) or as device in Telegram (for Profibus DP, Modbus TCP, PROFINET and EtherNet/IP).
- **Name**—Analog source parameters (used for mA output or High voltage relay) or Telegram tags (Telegram is used for digital and Ethernet protocols.)
- **Type**—Type of data: float (32 bits) or integer (16 bits)

¹⁹ For availability of the software modules, contact technical support.

- **mA-O**—Applicable to mA output (source)
- **HVR**—Applicable to high voltage relay (source)
- **P-DP**—Applicable to Profibus DP (Telegram)
- **M-TCP**—Applicable to Modbus TCP (Telegram)
- **PRN**—Applicable to PROFINET (Telegram)
- **E/IP**—Applicable to EtherNet/IP (Telegram)

Notes:

1. The first rows in the table that follows are the generic tags for SC devices. The generic tags for SC devices show on all of the SC devices. The tags are applicable in Telegram for Profibus DP, Modbus TCP, PROFINET and EtherNet/IP protocol. The tags are not applicable in source for mA output and High voltage relay.
 - The tags are "classified" because they apply to all of the sensors equally. Each bit of each register has the same meaning on all of the devices.
 - Heartbeat is a lower clock register. The register changes every second to show that read values are refreshed continuously.
2. Device Error Condition is 32 bits, integer type in the AN-ISE sc, AMTAX sc, PHOSPHAX sc LR, MR and HR, and pH-ORP analog module and pH-ORP Ultrapure analog module. For all of the other devices, the Device Error Condition is 16 bits, integer type.
3. Device Warning Condition is 32 bits, integer type in the AN-ISE sc, AMTAX sc, TU5x00 sc, analog inductive conductivity module (ICOND), pH-ORP analog module, ultrapure pH/ORP module and ultrapure conductivity module. For all of the other devices, the Device Warning Condition is 16 bits, integer type.

Note: The list of sensors that have 32 bits, integer type error and warning conditions can increase (e.g., with new sensors added that support 32-bit integers). Refer to the sensor documentation for details on the list of sensors and definitions of the warnings and errors.
4. To simplify the configuration, the new tags "Device Error Condition 1", "Device Error Condition 2", "Device Warning Condition 1" and "Device Warning Condition 2" have been added. The four new tags have a fixed size of 16 bits, integer type, which are the same as the division into two parts of the standard "Device Error Condition" and "Device Warning Condition".
5. SC4500— Select the controller itself to configure the Modbus TCP to import an external measurement. Refer to [Configure the Modbus TCP](#) on page 44.
6. mA output—It is not possible to select the local mA output itself or a remote mA output.

High voltage relay—It is not possible to select the local High voltage relay itself. If HCNB is ON, it is possible to select a remote high voltage relay.

7. Measurement indicator [%] and Service indicator [days] only shows if the sensor has Prognosys.

Device	Name	Type	mA-O	HVR	P-DP	M-TCP	PRN	E/IP
All SC devices (Generic tags for SC devices. Refer to Note 1.)	Classified Error	Integer	—	—	✓	✓	✓	✓
	Classified Status 1	Integer	—	—	✓	✓	✓	✓
	Classified Status 2	Integer	—	—	✓	✓	✓	✓
	Classified Status 3	Integer	—	—	✓	✓	✓	✓
	Classified Status 4	Integer	—	—	✓	✓	✓	✓
	Device Error Condition (refer to Notes 2 and 3)	Integer	—	—	✓	✓	✓	✓
	Device Error Condition 1 (refer to Note 4)	Integer	—	—	✓	✓	✓	✓
	Device Error Condition 2 (refer to Note 4)	Integer	—	—	✓	✓	✓	✓
	Device Warning Condition (refer to Notes 2 and 3)	Integer	—	—	✓	✓	✓	✓
	Device Warning Condition 1 (refer to Note 4)	Integer	—	—	✓	✓	✓	✓
	Device Warning Condition 2 (refer to Note 4)	Integer	—	—	✓	✓	✓	✓
	Heartbeat	Integer	—	—	✓	✓	✓	✓
SC4500 (refer to Note 5)	Measurement 1	Float	✓	✓	✓	✓	✓	✓
SC4500	Measurement 2	Float	✓	✓	✓	✓	✓	✓
SC4500	Measurement 3	Float	✓	✓	✓	✓	✓	✓
SC4500	Measurement 4	Float	✓	✓	✓	✓	✓	✓
SC4500	Measurement 5	Float	✓	✓	✓	✓	✓	✓
SC4500	Measurement 6	Float	✓	✓	✓	✓	✓	✓
SC4500	Measurement 7	Float	✓	✓	✓	✓	✓	✓
SC4500	Measurement 8	Float	✓	✓	✓	✓	✓	✓
SC4500	Measurement 9	Float	✓	✓	✓	✓	✓	✓
SC4500	Measurement 10	Float	✓	✓	✓	✓	✓	✓
SC4500	Measurement 11	Float	✓	✓	✓	✓	✓	✓
SC4500	Measurement 12	Float	✓	✓	✓	✓	✓	✓
SC4500	Measurement 13	Float	✓	✓	✓	✓	✓	✓
SC4500	Measurement 14	Float	✓	✓	✓	✓	✓	✓
SC4500	Measurement 15	Float	✓	✓	✓	✓	✓	✓
SC4500	Measurement 16	Float	✓	✓	✓	✓	✓	✓
SC4500	Measurement 17	Float	✓	✓	✓	✓	✓	✓
SC4500	Measurement 18	Float	✓	✓	✓	✓	✓	✓

Device	Name	Type	mA-O	HVR	P-DP	M-TCP	PRN	E/IP
SC4500	Measurement 19	Float	✓	✓	✓	✓	✓	✓
SC4500	Measurement 21	Float	✓	✓	✓	✓	✓	✓
SC4500	Measurement 22	Float	✓	✓	✓	✓	✓	✓
SC4500	Measurement 23	Float	✓	✓	✓	✓	✓	✓
SC4500	Measurement 24	Float	✓	✓	✓	✓	✓	✓
SC4500	Measurement 25	Float	✓	✓	✓	✓	✓	✓
SC4500	Measurement 26	Float	✓	✓	✓	✓	✓	✓
SC4500	Measurement 27	Float	✓	✓	✓	✓	✓	✓
SC4500	Measurement 28	Float	✓	✓	✓	✓	✓	✓
SC4500	Measurement 29	Float	✓	✓	✓	✓	✓	✓
SC4500	Measurement 30	Float	✓	✓	✓	✓	✓	✓
SC4500	Measurement 31	Float	✓	✓	✓	✓	✓	✓
SC4500	Measurement 32	Float	✓	✓	✓	✓	✓	✓

Device	Name	Type	mA-O	HVR	P-DP	M-TCP	PRN	E/IP
High voltage relay (refer to Note 6)	Generic tags for SC devices	Integer	—	—	✓	✓	✓	✓
High voltage relay	Contact Position ch1	Integer	✓	—	✓	✓	✓	✓
High voltage relay	Contact Position ch2	Integer	✓	—	✓	✓	✓	✓
High voltage relay	Input Value ch1	Float	✓	—	✓	✓	✓	✓
High voltage relay	Input Value ch2	Float	✓	—	✓	✓	✓	✓
mA Output (refer to Note 6)	Generic tags for SC devices	Integer	—	—	✓	✓	✓	✓
mA Output	Current ch1 [mA]	Float	—	✓	✓	✓	✓	✓
mA Output	Current ch2 [mA]	Float	—	✓	✓	✓	✓	✓
mA Output	Current ch3 [mA]	Float	—	✓	✓	✓	✓	✓
mA Output	Current ch4 [mA]	Float	—	✓	✓	✓	✓	✓
mA Output	Current ch5 [mA]	Float	—	✓	✓	✓	✓	✓
mA Output	Input Value ch1	Float	—	✓	✓	✓	✓	✓
mA Output	Input Value ch2	Float	—	✓	✓	✓	✓	✓
mA Output	Input Value ch3	Float	—	✓	✓	✓	✓	✓
mA Output	Input Value ch4	Float	—	✓	✓	✓	✓	✓
mA Output	Input Value ch5	Float	—	✓	✓	✓	✓	✓
Profibus DP	Generic tags for SC devices	Integer	—	—	✓	✓	✓	✓
Profibus DP	External measurement value 1	Float	✓	✓	✓	✓	✓	✓
Profibus DP	External measurement value 2	Float	✓	✓	✓	✓	✓	✓
Profibus DP	External measurement value 3	Float	✓	✓	✓	✓	✓	✓

Device	Name	Type	mA-O	HVR	P-DP	M-TCP	PRN	E/IP
Profibus DP	External measurement value 4	Float	✓	✓	✓	✓	✓	✓
Profibus DP	External measurement value 5	Float	✓	✓	✓	✓	✓	✓
Profibus DP	External measurement value 6	Float	✓	✓	✓	✓	✓	✓
Profibus DP	External measurement value 7	Float	✓	✓	✓	✓	✓	✓
Profibus DP	External measurement value 8	Float	✓	✓	✓	✓	✓	✓
PROFINET	Generic tags for SC devices	Integer	—	—	✓	✓	✓	✓
PROFINET	External measurement value 1	Float	✓	✓	✓	✓	✓	✓
PROFINET	External measurement value 2	Float	✓	✓	✓	✓	✓	✓
PROFINET	External measurement value 3	Float	✓	✓	✓	✓	✓	✓
PROFINET	External measurement value 4	Float	✓	✓	✓	✓	✓	✓
PROFINET	External measurement value 5	Float	✓	✓	✓	✓	✓	✓
PROFINET	External measurement value 6	Float	✓	✓	✓	✓	✓	✓
PROFINET	External measurement value 7	Float	✓	✓	✓	✓	✓	✓
PROFINET	External measurement value 8	Float	✓	✓	✓	✓	✓	✓
PROFINET	External measurement value 9	Float	✓	✓	✓	✓	✓	✓
PROFINET	External measurement value 10	Float	✓	✓	✓	✓	✓	✓
PROFINET	External measurement value 11	Float	✓	✓	✓	✓	✓	✓
PROFINET	External measurement value 12	Float	✓	✓	✓	✓	✓	✓
PROFINET	External measurement value 13	Float	✓	✓	✓	✓	✓	✓
PROFINET	External measurement value 14	Float	✓	✓	✓	✓	✓	✓
PROFINET	External measurement value 15	Float	✓	✓	✓	✓	✓	✓
PROFINET	External measurement value 16	Float	✓	✓	✓	✓	✓	✓
PROFINET	External measurement value 17	Float	✓	✓	✓	✓	✓	✓
PROFINET	External measurement value 18	Float	✓	✓	✓	✓	✓	✓
PROFINET	External measurement value 19	Float	✓	✓	✓	✓	✓	✓
PROFINET	External measurement value 20	Float	✓	✓	✓	✓	✓	✓
PROFINET	External measurement value 21	Float	✓	✓	✓	✓	✓	✓
PROFINET	External measurement value 22	Float	✓	✓	✓	✓	✓	✓
PROFINET	External measurement value 23	Float	✓	✓	✓	✓	✓	✓
PROFINET	External measurement value 24	Float	✓	✓	✓	✓	✓	✓
PROFINET	External measurement value 25	Float	✓	✓	✓	✓	✓	✓
PROFINET	External measurement value 26	Float	✓	✓	✓	✓	✓	✓
PROFINET	External measurement value 27	Float	✓	✓	✓	✓	✓	✓
PROFINET	External measurement value 28	Float	✓	✓	✓	✓	✓	✓
PROFINET	External measurement value 29	Float	✓	✓	✓	✓	✓	✓
PROFINET	External measurement value 30	Float	✓	✓	✓	✓	✓	✓

Device	Name	Type	mA-O	HVR	P-DP	M-TCP	PRN	E/IP
PROFINET	External measurement value 31	Float	✓	✓	✓	✓	✓	✓
PROFINET	External measurement value 32	Float	✓	✓	✓	✓	✓	✓
EtherNet/IP	Generic tags for SC devices	Integer	—	—	✓	✓	✓	✓
EtherNet/IP	External measurement value 1	Float	✓	✓	✓	✓	✓	✓
EtherNet/IP	External measurement value 2	Float	✓	✓	✓	✓	✓	✓
EtherNet/IP	External measurement value 3	Float	✓	✓	✓	✓	✓	✓
EtherNet/IP	External measurement value 4	Float	✓	✓	✓	✓	✓	✓
EtherNet/IP	External measurement value 5	Float	✓	✓	✓	✓	✓	✓
EtherNet/IP	External measurement value 6	Float	✓	✓	✓	✓	✓	✓
EtherNet/IP	External measurement value 7	Float	✓	✓	✓	✓	✓	✓
EtherNet/IP	External measurement value 8	Float	✓	✓	✓	✓	✓	✓
EtherNet/IP	External measurement value 9	Float	✓	✓	✓	✓	✓	✓
EtherNet/IP	External measurement value 10	Float	✓	✓	✓	✓	✓	✓
EtherNet/IP	External measurement value 11	Float	✓	✓	✓	✓	✓	✓
EtherNet/IP	External measurement value 12	Float	✓	✓	✓	✓	✓	✓
EtherNet/IP	External measurement value 13	Float	✓	✓	✓	✓	✓	✓
EtherNet/IP	External measurement value 14	Float	✓	✓	✓	✓	✓	✓
EtherNet/IP	External measurement value 15	Float	✓	✓	✓	✓	✓	✓
EtherNet/IP	External measurement value 16	Float	✓	✓	✓	✓	✓	✓
EtherNet/IP	External measurement value 17	Float	✓	✓	✓	✓	✓	✓
EtherNet/IP	External measurement value 18	Float	✓	✓	✓	✓	✓	✓
EtherNet/IP	External measurement value 19	Float	✓	✓	✓	✓	✓	✓
EtherNet/IP	External measurement value 20	Float	✓	✓	✓	✓	✓	✓
EtherNet/IP	External measurement value 21	Float	✓	✓	✓	✓	✓	✓
EtherNet/IP	External measurement value 22	Float	✓	✓	✓	✓	✓	✓
EtherNet/IP	External measurement value 23	Float	✓	✓	✓	✓	✓	✓
EtherNet/IP	External measurement value 24	Float	✓	✓	✓	✓	✓	✓
EtherNet/IP	External measurement value 25	Float	✓	✓	✓	✓	✓	✓
EtherNet/IP	External measurement value 26	Float	✓	✓	✓	✓	✓	✓
EtherNet/IP	External measurement value 27	Float	✓	✓	✓	✓	✓	✓
EtherNet/IP	External measurement value 28	Float	✓	✓	✓	✓	✓	✓
EtherNet/IP	External measurement value 29	Float	✓	✓	✓	✓	✓	✓
EtherNet/IP	External measurement value 30	Float	✓	✓	✓	✓	✓	✓
EtherNet/IP	External measurement value 31	Float	✓	✓	✓	✓	✓	✓
EtherNet/IP	External measurement value 32	Float	✓	✓	✓	✓	✓	✓
mA input	Generic tags for SC devices	Integer	—	—	✓	✓	✓	✓

Device	Name	Type	mA-O	HVR	P-DP	M-TCP	PRN	E/IP
mA input	Current [mA]	Float	✓	✓	✓	✓	✓	✓
mA input	Input	Float	✓	✓	✓	✓	✓	✓

Device	Name	Type	mA-O	HVR	P-DP	M-TCP	PRN	E/IP
Conductivity module (CCO)	Generic tags for SC devices	Integer	—	—	✓	✓	✓	✓
Conductivity module (CCO)	Conductivity	Float	✓	✓	✓	✓	✓	✓
Conductivity module (CCO)	Resistivity	Float	✓	✓	✓	✓	✓	✓
Conductivity module (CCO)	Salinity [ppt]	Float	✓	✓	✓	✓	✓	✓
Conductivity module (CCO)	Temperature [°F]	Float	✓	✓	✓	✓	✓	✓
Conductivity module (CCO)	Temperature [°C]	Float	✓	✓	✓	✓	✓	✓
Conductivity module (CCO)	Total Dissolved Solids (TDS)	Float	✓	✓	✓	✓	✓	✓
Conductivity module (ICO)	Generic tagTotal Dissolved Solids (TDS)s for SC devices	Integer	—	—	✓	✓	✓	✓
Conductivity module (ICO)	Concentration [%]	Float	✓	✓	✓	✓	✓	✓
Conductivity module (ICO)	Conductivity [μS/cm]	Float	✓	✓	✓	✓	✓	✓
Conductivity module (ICO)	Conductivity [mS/cm]	Float	✓	✓	✓	✓	✓	✓
Conductivity module (ICO)	Conductivity [S/cm]	Float	✓	✓	✓	✓	✓	✓
Conductivity module (ICO)	Salinity [ppt]	Float	✓	✓	✓	✓	✓	✓
Conductivity module (ICO)	Temperature [°F]	Float	✓	✓	✓	✓	✓	✓
Conductivity module (ICO)	Temperature [°C]	Float	✓	✓	✓	✓	✓	✓
Conductivity module (ICO)	Total Dissolved Solids (TDS) [ppm]	Float	✓	✓	✓	✓	✓	✓
pH/ORP module	Generic tags for SC devices	Integer	—	—	✓	✓	✓	✓
pH/ORP module	pH [pH]	Float	✓	✓	✓	✓	✓	✓
pH/ORP module	ORP [mV]	Float	✓	✓	✓	✓	✓	✓
pH/ORP module	Temperature NTC300 [°C]	Float	✓	✓	✓	✓	✓	✓
pH/ORP module	Temperature platinum [°C]	Float	✓	✓	✓	✓	✓	✓
pH/ORP module	Temperature NTC300 [°F]	Float	✓	✓	✓	✓	✓	✓
pH/ORP module	Temperature platinum [°F]	Float	✓	✓	✓	✓	✓	✓
pH/ORP module	User temperature [°C]	Float	✓	✓	✓	✓	✓	✓
pH/ORP module	User temperature [°F]	Float	✓	✓	✓	✓	✓	✓
Ultrasure pH/ORP module	Generic tags for SC devices	Integer	—	—	✓	✓	✓	✓

Device	Name	Type	mA-O	HVR	P-DP	M-TCP	PRN	E/IP
Ultrapure pH/ORP module	ORP [mV]	Float	✓	✓	✓	✓	✓	✓
Ultrapure pH/ORP module	pH [pH]	Float	✓	✓	✓	✓	✓	✓
Ultrapure pH/ORP module	Temperature [°C]	Float	✓	✓	✓	✓	✓	✓
Ultrapure pH/ORP module	Temperature [°F]	Float	✓	✓	✓	✓	✓	✓
Ultrapure pH/ORP module	Temperature platinum [°C]	Float	✓	✓	✓	✓	✓	✓
Ultrapure pH/ORP module	Temperature platinum [°F]	Float	✓	✓	✓	✓	✓	✓
Ultrapure pH/ORP module	User temperature [°C]	Float	✓	✓	✓	✓	✓	✓
Ultrapure pH/ORP module	User temperature [°F]	Float	✓	✓	✓	✓	✓	✓
Ultrapure contacting conductivity (CCOND) module	Generic tags for SC devices	Integer	—	—	✓	✓	✓	✓
Ultrapure contacting conductivity (CCOND) module	ORP [mV]	Float	✓	✓	✓	✓	✓	✓
Ultrapure contacting conductivity (CCOND) module	Conductivity	Float	✓	✓	✓	✓	✓	✓
Ultrapure contacting conductivity (CCOND) module	Temperature [°C]	Float	✓	✓	✓	✓	✓	✓
Ultrapure contacting conductivity (CCOND) module	Resistivity	Float	✓	✓	✓	✓	✓	✓
Ultrapure contacting conductivity (CCOND) module	Total Dissolved Solids (TDS) [ppm]	Float	✓	✓	✓	✓	✓	✓
Ultrapure contacting conductivity (CCOND) module	Salinity [ppt]	Float	✓	✓	✓	✓	✓	✓
Ultrapure contacting conductivity (CCOND) module	Temperature [°F]	Float	✓	✓	✓	✓	✓	✓
Ultrapure inductive conductivity (ICOND) module	Generic tags for SC devices	Integer	—	—	✓	✓	✓	✓
Ultrapure inductive conductivity (ICOND) module	Conductivity [µS/cm]	Float	✓	✓	✓	✓	✓	✓
Ultrapure inductive conductivity (ICOND) module	Temperature [°C]	Float	✓	✓	✓	✓	✓	✓
Ultrapure inductive conductivity (ICOND) module	Concentration [%]	Float	✓	✓	✓	✓	✓	✓
Ultrapure inductive conductivity (ICOND) module	Total Dissolved Solids (TDS) [ppm]	Float	✓	✓	✓	✓	✓	✓
Ultrapure inductive conductivity (ICOND) module	Salinity [ppt]	Float	✓	✓	✓	✓	✓	✓
Ultrapure inductive conductivity (ICOND) module	Conductivity [mS/cm]	Float	✓	✓	✓	✓	✓	✓
Ultrapure inductive conductivity (ICOND) module	Conductivity [S/cm]	Float	✓	✓	✓	✓	✓	✓
Ultrapure inductive conductivity (ICOND) module	Resistivity	Float	✓	✓	✓	✓	✓	✓

Device	Name	Type	mA-O	HVR	P-DP	M-TCP	PRN	E/IP
Ultrapure inductive conductivity (ICOND) module	Temperature [°F]	Float	✓	✓	✓	✓	✓	✓
Ultrapure amperometric module—2586sc O2 Scavenger	Generic tags for SC devices	Integer	—	—	✓	✓	✓	✓
Ultrapure amperometric module—2586sc O2 Scavenger	O2 Scavenger [ppm]	Float	✓	✓	✓	✓	✓	✓
Ultrapure amperometric module—2586sc O2 Scavenger	O2 Scavenger [mg/L]	Float	✓	✓	✓	✓	✓	✓
Ultrapure amperometric module—2586sc O2 Scavenger	O2 Scavenger [ppb]	Float	✓	✓	✓	✓	✓	✓
Ultrapure amperometric module—2586sc O2 Scavenger	O2 Scavenger [µg/L]	Float	✓	✓	✓	✓	✓	✓
Ultrapure amperometric module—2586sc O2 Scavenger	Temperature [°C]	Float	✓	✓	✓	✓	✓	✓
Ultrapure amperometric module—2586sc O2 Scavenger	Temperature [°F]	Float	✓	✓	✓	✓	✓	✓
Ultrapure amperometric module—2582sc DO analyzer	Generic tags for SC devices	Integer	—	—	✓	✓	✓	✓
Ultrapure amperometric module—2582sc DO analyzer	Dissolved Oxygen [ppm]	Float	✓	✓	✓	✓	✓	✓
Ultrapure amperometric module—2582sc DO analyzer	Dissolved Oxygen [mg/L]	Float	✓	✓	✓	✓	✓	✓
Ultrapure amperometric module—2582sc DO analyzer	Dissolved Oxygen [ppb]	Float	✓	✓	✓	✓	✓	✓
Ultrapure amperometric module—2582sc DO analyzer	Dissolved Oxygen [µg/L]	Float	✓	✓	✓	✓	✓	✓
Ultrapure amperometric module—2582sc DO analyzer	Dissolved Oxygen [mbar]	Float	✓	✓	✓	✓	✓	✓
Ultrapure amperometric module—2582sc DO analyzer	Dissolved Oxygen [hPa]	Float	✓	✓	✓	✓	✓	✓
Ultrapure amperometric module—2582sc DO analyzer	Dissolved Oxygen [inHg]	Float	✓	✓	✓	✓	✓	✓
Ultrapure amperometric module—2582sc DO analyzer	Dissolved Oxygen [mmHg]	Float	✓	✓	✓	✓	✓	✓
Ultrapure amperometric module—2582sc DO analyzer	Temperature [°C]	Float	✓	✓	✓	✓	✓	✓
Ultrapure amperometric module—2582sc DO analyzer	Temperature [°F]	Float	✓	✓	✓	✓	✓	✓

Device	Name	Type	mA-O	HVR	P-DP	M-TCP	PRN	E/IP
AMTAX sc	Measurement indicator [%] (refer to Note 7)	Integer	—	—	✓	✓	✓	✓
AMTAX sc	Service indicator [days] (refer to Note 7)	Integer	—	—	✓	✓	✓	✓
AMTAX sc	Generic tags for SC devices	Integer	—	—	✓	✓	✓	✓
AMTAX sc	Ammonium NH ₄ ch1 [mg/L or ppm]	Float	✓	✓	✓	✓	✓	✓
AMTAX sc	Ammonium NH ₄ ch2 [mg/L or ppm]	Float	✓	✓	✓	✓	✓	✓
AMTAX sc	Ammonium NH ₄ -N ch1 [mg/L or ppm]	Float	✓	✓	✓	✓	✓	✓
AMTAX sc	Ammonium NH ₄ -N ch2 [mg/L or ppm]	Float	✓	✓	✓	✓	✓	✓
AMTAX sc	Cleaning solution level [%]	Float	✓	✓	✓	✓	✓	✓
AMTAX sc	Enclosure temperature [°C]	Float	✓	✓	✓	✓	✓	✓
AMTAX sc	Last electrode exchange date	Float	✓	✓	✓	✓	✓	✓
AMTAX sc	Last membrane exchange date	Float	✓	✓	✓	✓	✓	✓
AMTAX sc	mV from active Sample	Float	✓	✓	✓	✓	✓	✓
AMTAX sc	Process state	Float	✓	✓	✓	✓	✓	✓
AMTAX sc	Reagent Level [%]	Float	✓	✓	✓	✓	✓	✓
AMTAX sc	Slope of electrode mV	Float	✓	✓	✓	✓	✓	✓
AMTAX sc	Standards Level [%]	Float	✓	✓	✓	✓	✓	✓
A-ISE sc	Measurement indicator [%] (refer to Note 7)	Integer	—	—	✓	✓	✓	✓
A-ISE sc	Service indicator [days] (refer to Note 7)	Integer	—	—	✓	✓	✓	✓
A-ISE sc	Generic tags for SC devices	Integer	—	—	✓	✓	✓	✓
A-ISE sc	Ammonium NH ₄ [mg/L]	Float	✓	✓	✓	✓	✓	✓
A-ISE sc	Ammonium NH ₄ -N [mg/L]	Float	✓	✓	✓	✓	✓	✓
A-ISE sc	Potassium K [mg/L]	Float	✓	✓	✓	✓	✓	✓
A-ISE sc	Temperature [°C]	Float	✓	✓	✓	✓	✓	✓
A-ISE sc	Temperature [°F]	Float	✓	✓	✓	✓	✓	✓
AN-ISE sc	Measurement indicator [%] (refer to Note 7)	Integer	—	—	✓	✓	✓	✓
AN-ISE sc	Service indicator [days] (refer to Note 7)	Integer	—	—	✓	✓	✓	✓
AN-ISE sc	Generic tags for SC devices	Integer	—	—	✓	✓	✓	✓
AN-ISE sc	Ammonium NH ₄ [mg/L]	Float	✓	✓	✓	✓	✓	✓
AN-ISE sc	Ammonium NH ₄ -N [mg/L]	Float	✓	✓	✓	✓	✓	✓
AN-ISE sc	Chloride Cl [mg/L]	Float	✓	✓	✓	✓	✓	✓
AN-ISE sc	Nitrate NO ₃ [mg/L]	Float	✓	✓	✓	✓	✓	✓

Device	Name	Type	mA-O	HVR	P-DP	M-TCP	PRN	E/IP
AN-ISE sc	Nitrate NO ₃ -N [mg/L]	Float	✓	✓	✓	✓	✓	✓
AN-ISE sc	Potassium K [mg/L]	Float	✓	✓	✓	✓	✓	✓
AN-ISE sc	Temperature [°C]	Float	✓	✓	✓	✓	✓	✓
AN-ISE sc	Temperature [°F]	Float	✓	✓	✓	✓	✓	✓
N-ISE sc	Measurement indicator [%] (refer to Note 7)	Integer	—	—	✓	✓	✓	✓
N-ISE sc	Service indicator [days] (refer to Note 7)	Integer	—	—	✓	✓	✓	✓
N-ISE sc	Generic tags for SC devices	Integer	—	—	✓	✓	✓	✓
N-ISE sc	Chloride Cl [mg/L]	Float	✓	✓	✓	✓	✓	✓
N-ISE sc	Nitrate NO ₃ [mg/L]	Float	✓	✓	✓	✓	✓	✓
N-ISE sc	Nitrate NO ₃ -N [mg/L]	Float	✓	✓	✓	✓	✓	✓
N-ISE sc	Temperature [°C]	Float	✓	✓	✓	✓	✓	✓
N-ISE sc	Temperature [°F]	Float	✓	✓	✓	✓	✓	✓
CDx440sc Gateway	Generic tags for SC devices	Integer	—	—	✓	✓	✓	✓
CDx440sc Gateway	Measurement indicator [%] (refer to Note 7)	Integer	—	—	✓	✓	✓	✓
CDx440sc Gateway	Service indicator [days] (refer to Note 7)	Integer	—	—	✓	✓	✓	✓
CDx440sc Gateway	H ₂ S in liquid [mg/L]	Float	✓	✓	✓	✓	✓	✓
CDx440sc Gateway	H ₂ S in gas [ppm]	Float	✓	✓	✓	✓	✓	✓
CDx440sc Gateway	Temperature [°C]	Float	✓	✓	✓	✓	✓	✓
CL 17 sc	Measurement indicator [%] (refer to Note 7)	Integer	—	—	✓	✓	✓	✓
CL 17 sc	Service indicator [days] (refer to Note 7)	Integer	—	—	✓	✓	✓	✓
CL 17 sc	Generic tags for SC devices	Integer	—	—	✓	✓	✓	✓
CL 17 sc	Vol [mL/min]	Float	✓	✓	✓	✓	✓	✓
CL 17 sc	Free chlorine [mg/L]	Float	✓	✓	✓	✓	✓	✓
CL 17 sc	Total chlorine [mg/L]	Float	✓	✓	✓	✓	✓	✓
CL 17 sc	LED Drive [%]	Float	✓	✓	✓	✓	✓	✓
CL 10 sc	Generic tags for SC devices	Integer	—	—	✓	✓	✓	✓
CL 10 sc	Free chlorine	Float	✓	✓	✓	✓	✓	✓
CL 10 sc	pH [pH]	Float	✓	✓	✓	✓	✓	✓
CL 10 sc	Temperature	Float	✓	✓	✓	✓	✓	✓
FP360 sc	Generic tags for SC devices	Integer	—	—	✓	✓	✓	✓
FP360 sc	PAH [ppb]	Float	✓	✓	✓	✓	✓	✓
FP360 sc	PAH [ppm]	Float	✓	✓	✓	✓	✓	✓
FP360 sc	OIL [ppb]	Float	✓	✓	✓	✓	✓	✓

Device	Name	Type	mA-O	HVR	P-DP	M-TCP	PRN	E/IP
FP360 sc	OIL [ppm]	Float	✓	✓	✓	✓	✓	✓
LDO2 sc	Measurement indicator [%] (refer to Note 7)	Integer	—	—	✓	✓	✓	✓
LDO2 sc	Service indicator [days] (refer to Note 7)	Integer	—	—	✓	✓	✓	✓
LDO2 sc	Generic tags for SC devices	Integer	—	—	✓	✓	✓	✓
LDO2 sc	Dissolved Oxygen [%]	Float	✓	✓	✓	✓	✓	✓
LDO2 sc	Dissolved Oxygen [mg/L]	Float	✓	✓	✓	✓	✓	✓
LDO2 sc	Dissolved Oxygen [ppm]	Float	✓	✓	✓	✓	✓	✓
LDO2 sc	Temperature [°C]	Float	✓	✓	✓	✓	✓	✓
LDO2 sc	Temperature [°F]	Float	✓	✓	✓	✓	✓	✓
Nitratax60 sc	Measurement indicator [%] (refer to Note 7)	Integer	—	—	✓	✓	✓	✓
Nitratax60 sc	Service indicator [days] (refer to Note 7)	Integer	—	—	✓	✓	✓	✓
Nitratax60 sc	Generic tags for SC devices	Integer	—	—	✓	✓	✓	✓
Nitratax60 sc	Nitrate NO ₃ or NO _x -N [mg/L]	Float	✓	✓	✓	✓	✓	✓
Nitratax eco sc	Measurement indicator [%] (refer to Note 7)	Integer	—	—	✓	✓	✓	✓
Nitratax eco sc	Service indicator [days] (refer to Note 7)	Integer	—	—	✓	✓	✓	✓
Nitratax eco sc	Generic tags for SC devices	Integer	—	—	✓	✓	✓	✓
Nitratax eco sc	Nitrate NO ₃ or NO _x -N [mg/L]	Float	✓	✓	✓	✓	✓	✓
Nitratax plus sc	Measurement indicator [%] (refer to Note 7)	Integer	—	—	✓	✓	✓	✓
Nitratax plus sc	Service indicator [days] (refer to Note 7)	Integer	—	—	✓	✓	✓	✓
Nitratax plus sc	Generic tags for SC devices	Integer	—	—	✓	✓	✓	✓
Nitratax plus sc	Nitrate NO ₃ or NO _x -N [mg/L]	Float	✓	✓	✓	✓	✓	✓
Nitratax clear sc	Measurement indicator [%] (refer to Note 7)	Integer	—	—	✓	✓	✓	✓
Nitratax clear sc	Service indicator [days] (refer to Note 7)	Integer	—	—	✓	✓	✓	✓
Nitratax clear sc	Generic tags for SC devices	Integer	—	—	✓	✓	✓	✓
Nitratax clear sc	Nitrate NO ₃ or NO _x -N [mg/L]	Float	✓	✓	✓	✓	✓	✓
Nitratax sc (Germany only)	Measurement indicator [%] (refer to Note 7)	Integer	—	—	✓	✓	✓	✓
Nitratax sc (Germany only)	Service indicator [days] (refer to Note 7)	Integer	—	—	✓	✓	✓	✓
Nitratax sc (Germany only)	Generic tags for SC devices	Integer	—	—	✓	✓	✓	✓

Device	Name	Type	mA-O	HVR	P-DP	M-TCP	PRN	E/IP
Nitratax sc (Germany only)	Nitrate NO ₃ or NO _x -N [mg/L]	Float	✓	✓	✓	✓	✓	✓
NT3100sc	Generic tags for SC devices	Integer	—	—	✓	✓	✓	✓
NT3100sc	Measurement indicator [%] (refer to Note 7)	Integer	—	—	✓	✓	✓	✓
NT3100sc	Service indicator [days] (refer to Note 7)	Integer	—	—	✓	✓	✓	✓
NT3100sc	NO ₃	Float	✓	✓	✓	✓	✓	✓
NT3100sc	NO ₃ -N	Float	✓	✓	✓	✓	✓	✓
NT3100sc	NO _x	Float	✓	✓	✓	✓	✓	✓
NT3100sc	NO _x -N	Float	✓	✓	✓	✓	✓	✓
NT3200sc	Generic tags for SC devices	Integer	—	—	✓	✓	✓	✓
NT3200sc	Measurement indicator [%] (refer to Note 7)	Integer	—	—	✓	✓	✓	✓
NT3200sc	Service indicator [days] (refer to Note 7)	Integer	—	—	✓	✓	✓	✓
NT3200sc	NO ₂	Float	✓	✓	✓	✓	✓	✓
NT3200sc	NO ₂ -N	Float	✓	✓	✓	✓	✓	✓
NT3200sc	NO ₃	Float	✓	✓	✓	✓	✓	✓
NT3200sc	NO ₃ -N	Float	✓	✓	✓	✓	✓	✓
NT3200sc	NO _x	Float	✓	✓	✓	✓	✓	✓
NT3200sc	NO _x -N	Float	✓	✓	✓	✓	✓	✓
PHOSPHAX sc LR	Measurement indicator [%] (refer to Note 7)	Integer	—	—	✓	✓	✓	✓
PHOSPHAX sc LR	Service indicator [days] (refer to Note 7)	Integer	—	—	✓	✓	✓	✓
PHOSPHAX sc LR	Generic tags for SC devices	Integer	—	—	✓	✓	✓	✓
PHOSPHAX sc LR	Phosphate-Phosphorus PO ₄ -P [mg/L or ppm]	Float	✓	✓	✓	✓	✓	✓
PHOSPHAX sc LR	Phosphate PO ₄ [mg/L or ppm]	Float	✓	✓	✓	✓	✓	✓
PHOSPHAX sc LR	Phosphorus Pentoxide P ₂ O ₅ [mg/L or ppm]	Float	✓	✓	✓	✓	✓	✓
PHOSPHAX sc MR	Generic tags for SC devices	Integer	—	—	✓	✓	✓	✓
PHOSPHAX sc MR	Measurement indicator [%] (refer to Note 7)	Integer	—	—	✓	✓	✓	✓
PHOSPHAX sc MR	Service indicator [days] (refer to Note 7)	Integer	—	—	✓	✓	✓	✓
PHOSPHAX sc MR	Cleaning solution level [%]	Float	✓	✓	✓	✓	✓	✓
PHOSPHAX sc MR	Phosphate-Phosphorus PO ₄ -P ch1 [mg/L or ppm]	Float	✓	✓	✓	✓	✓	✓
PHOSPHAX sc MR	Phosphate-Phosphorus PO ₄ -P ch2 [mg/L or ppm]	Float	✓	✓	✓	✓	✓	✓

Device	Name	Type	mA-O	HVR	P-DP	M-TCP	PRN	E/IP
PHOSPHAX sc MR	Phosphate PO ₄ ch1 [mg/L or ppm]	Float	✓	✓	✓	✓	✓	✓
PHOSPHAX sc MR	Phosphate PO ₄ ch2 [mg/L or ppm]	Float	✓	✓	✓	✓	✓	✓
PHOSPHAX sc MR	Phosphorus Pentoxide P ₂ O ₅ ch1 [mg/L or ppm]	Float	✓	✓	✓	✓	✓	✓
PHOSPHAX sc MR	Phosphorus Pentoxide P ₂ O ₅ ch2 [mg/L or ppm]	Float	✓	✓	✓	✓	✓	✓
PHOSPHAX sc MR	Process state	Float	✓	✓	✓	✓	✓	✓
PHOSPHAX sc MR	Reagent Level [%]	Float	✓	✓	✓	✓	✓	✓
PHOSPHAX sc HR	Generic tags for SC devices	Integer	—	—	✓	✓	✓	✓
PHOSPHAX sc HR	Measurement indicator [%] (refer to Note 7)	Integer	—	—	✓	✓	✓	✓
PHOSPHAX sc HR	Service indicator [days] (refer to Note 7)	Integer	—	—	✓	✓	✓	✓
PHOSPHAX sc HR	Cleaning solution level [%]	Float	✓	✓	✓	✓	✓	✓
PHOSPHAX sc HR	Phosphate-Phosphorus PO ₄ -P ch1 [mg/L or ppm]	Float	✓	✓	✓	✓	✓	✓
PHOSPHAX sc HR	Phosphate-Phosphorus PO ₄ -P ch2 [mg/L or ppm]	Float	✓	✓	✓	✓	✓	✓
PHOSPHAX sc HR	Phosphate PO ₄ ch1 [mg/L or ppm]	Float	✓	✓	✓	✓	✓	✓
PHOSPHAX sc HR	Phosphate PO ₄ ch2 [mg/L or ppm]	Float	✓	✓	✓	✓	✓	✓
PHOSPHAX sc HR	Phosphorus Pentoxide P ₂ O ₅ ch1 [mg/L or ppm]	Float	✓	✓	✓	✓	✓	✓
PHOSPHAX sc HR	Phosphorus Pentoxide P ₂ O ₅ ch2 [mg/L or ppm]	Float	✓	✓	✓	✓	✓	✓
PHOSPHAX sc HR	Process state	Float	✓	✓	✓	✓	✓	✓
PHOSPHAX sc HR	Reagent Level [%]	Float	✓	✓	✓	✓	✓	✓
pHD sc V2	Generic tags for SC devices	Integer	—	—	✓	✓	✓	✓
pHD sc V2	ORP [mV]	Float	✓	✓	✓	✓	✓	✓
pHD sc V2	Temperature [°C]	Float	✓	✓	✓	✓	✓	✓
pHD sc V2	Temperature [°F]	Float	✓	✓	✓	✓	✓	✓
pHD sc V2	pH [pH]	Float	✓	✓	✓	✓	✓	✓
SOLITAX sc	Generic tags for SC devices	Integer	—	—	✓	✓	✓	✓
SOLITAX sc	Measurement indicator [%] (refer to Note 7)	Float	—	—	✓	✓	✓	✓
SOLITAX sc	Service indicator [days] (refer to Note 7)	Float	—	—	✓	✓	✓	✓
SOLITAX sc	Solids [%]	Float	✓	✓	✓	✓	✓	✓
SOLITAX sc	Solids [g/L]	Float	✓	✓	✓	✓	✓	✓

Device	Name	Type	mA-O	HVR	P-DP	M-TCP	PRN	E/IP
SOLITAX sc	Solids [mg/L]	Float	✓	✓	✓	✓	✓	✓
SOLITAX sc	Solids [ppm]	Float	✓	✓	✓	✓	✓	✓
SOLITAX sc	Turbidity [EBC]	Float	✓	✓	✓	✓	✓	✓
SOLITAX sc	Turbidity [FTU]	Float	✓	✓	✓	✓	✓	✓
SOLITAX sc	Turbidity [FNU]	Float	✓	✓	✓	✓	✓	✓
SOLITAX sc	Turbidity [NTU]	Float	✓	✓	✓	✓	✓	✓
SOLITAX sc	Turbidity [TEF]	Float	✓	✓	✓	✓	✓	✓
SONATAX sc	Generic tags for SC devices	Integer	—	—	✓	✓	✓	✓
SONATAX sc	Measurement indicator [%] (refer to Note 7)	Integer	—	—	✓	✓	✓	✓
SONATAX sc	Service indicator [days] (refer to Note 7)	Integer	—	—	✓	✓	✓	✓
SONATAX sc	Sludge level [ft]	Float	✓	✓	✓	✓	✓	✓
SONATAX sc	Sludge level [m]	Float	✓	✓	✓	✓	✓	✓
SONATAX sc	Sludge level [ft]	Float	✓	✓	✓	✓	✓	✓
SONATAX sc	Sludge level [m]	Float	✓	✓	✓	✓	✓	✓
TSS sc	Generic tags for SC devices	Integer	—	—	✓	✓	✓	✓
TSS sc	Solids [%]	Float	✓	✓	✓	✓	✓	✓
TSS sc	Solids [g/L]	Float	✓	✓	✓	✓	✓	✓
TSS sc	Solids [mg/L]	Float	✓	✓	✓	✓	✓	✓
TSS sc	Solids [ppm]	Float	✓	✓	✓	✓	✓	✓
TSS sc	Turbidity [EBC]	Float	✓	✓	✓	✓	✓	✓
TSS sc	Turbidity [FTU]	Float	✓	✓	✓	✓	✓	✓
TSS sc	Turbidity [FNU]	Float	✓	✓	✓	✓	✓	✓
TSS sc	Turbidity [NTU]	Float	✓	✓	✓	✓	✓	✓
TSS sc	Turbidity [TEF]	Float	✓	✓	✓	✓	✓	✓
TU5300 sc	Generic tags for SC devices	Integer	—	—	✓	✓	✓	✓
TU5300 sc	Measurement indicator [%] (refer to Note 7)	Integer	—	—	✓	✓	✓	✓
TU5300 sc	Service indicator [days] (refer to Note 7)	Integer	—	—	✓	✓	✓	✓
TU5300 sc	Flow [L/min]	Float	✓	✓	✓	✓	✓	✓
TU5300 sc	Turbidity [DEG]	Float	✓	✓	✓	✓	✓	✓
TU5300 sc	Turbidity [EBC]	Float	✓	✓	✓	✓	✓	✓
TU5300 sc	Turbidity [FTU]	Float	✓	✓	✓	✓	✓	✓
TU5300 sc	Turbidity [FNU]	Float	✓	✓	✓	✓	✓	✓
TU5300 sc	Turbidity [NTU]	Float	✓	✓	✓	✓	✓	✓
TU5300 sc	Turbidity [TEF]	Float	✓	✓	✓	✓	✓	✓

Device	Name	Type	mA-O	HVR	P-DP	M-TCP	PRN	E/IP
TU5400 sc	Generic tags for SC devices	Integer	—	—	✓	✓	✓	✓
TU5400 sc	Measurement indicator [%] (refer to Note 7)	Integer	—	—	✓	✓	✓	✓
TU5400 sc	Service indicator [days] (refer to Note 7)	Integer	—	—	✓	✓	✓	✓
TU5400 sc	Flow [L/min]	Float	✓	✓	✓	✓	✓	✓
TU5400 sc	Relative Standard Deviation [%]	Float	✓	✓	✓	✓	✓	✓
TU5400 sc	Turbidity [DEG]	Float	✓	✓	✓	✓	✓	✓
TU5400 sc	Turbidity [EBC]	Float	✓	✓	✓	✓	✓	✓
TU5400 sc	Turbidity [FTU]	Float	✓	✓	✓	✓	✓	✓
TU5400 sc	Turbidity [FNU]	Float	✓	✓	✓	✓	✓	✓
TU5400 sc	Turbidity [mFNU]	Float	✓	✓	✓	✓	✓	✓
TU5400 sc	Turbidity [mNTU]	Float	✓	✓	✓	✓	✓	✓
TU5400 sc	Turbidity [NTU]	Float	✓	✓	✓	✓	✓	✓
TU5400 sc	Turbidity [TEF]	Float	✓	✓	✓	✓	✓	✓
SS7 sc	Generic tags for SC devices	Integer	—	—	✓	✓	✓	✓
SS7 sc	Turbidity	Float	✓	✓	✓	✓	✓	✓
Ultraturb Seawater	Generic tags for SC devices	Integer	—	—	✓	✓	✓	✓
Ultraturb Seawater	Turbidity	Float	✓	✓	✓	✓	✓	✓
1720E Low Range Turbidimeter	Generic tags for SC devices	Integer	—	—	✓	✓	✓	✓
1720E Low Range Turbidimeter	Turbidity	Float	✓	✓	✓	✓	✓	✓
UVASplus sc	Generic tags for SC devices	Integer	—	—	✓	✓	✓	✓
UVASplus sc	Selected Parameter [selected unit]	Float	✓	✓	✓	✓	✓	✓
UVASeco sc	Generic tags for SC devices	Integer	—	—	✓	✓	✓	✓
UVASeco sc	Selected Parameter [selected unit]	Float	✓	✓	✓	✓	✓	✓
1200-S sc V2	Generic tags for SC devices	Integer	—	—	✓	✓	✓	✓
1200-S sc V2	ORP [mV]	Float	✓	✓	✓	✓	✓	✓
1200-S sc V2	pH [pH]	Float	✓	✓	✓	✓	✓	✓
1200-S sc V2	Temperature [°C]	Float	✓	✓	✓	✓	✓	✓
1200-S sc V2	Temperature [°F]	Float	✓	✓	✓	✓	✓	✓
3798-S sc V2	Generic tags for SC devices	Integer	—	—	✓	✓	✓	✓
3798-S sc V2	Conductivity [µS/cm]	Float	✓	✓	✓	✓	✓	✓
3798-S sc V2	Conductivity [mS/cm]	Float	✓	✓	✓	✓	✓	✓
3798-S sc V2	Conductivity [S/cm]	Float	✓	✓	✓	✓	✓	✓
3798-S sc V2	Resistivity [Ohm.cm]	Float	✓	✓	✓	✓	✓	✓

Device	Name	Type	mA-O	HVR	P-DP	M-TCP	PRN	E/IP
3798-S sc V2	Resistivity [Ohm.m]	Float	✓	✓	✓	✓	✓	✓
3798-S sc V2	Temperature [°C]	Float	✓	✓	✓	✓	✓	✓
3798-S sc V2	Temperature [°F]	Float	✓	✓	✓	✓	✓	✓
9184 sc	Generic tags for SC devices	Integer	—	—	✓	✓	✓	✓
9184 sc	Concentration [mg/L]	Float	✓	✓	✓	✓	✓	✓
9184 sc	Concentration [ppb]	Float	✓	✓	✓	✓	✓	✓
9184 sc	Concentration [ppm]	Float	✓	✓	✓	✓	✓	✓
9184 sc	Concentration [µg/L]	Float	✓	✓	✓	✓	✓	✓
9184 sc	Current [nA]	Float	✓	✓	✓	✓	✓	✓
9184 sc	Current [µA]	Float	✓	✓	✓	✓	✓	✓
9184 sc	Temperature [°C]	Float	✓	✓	✓	✓	✓	✓
9184 sc	Temperature [°F]	Float	✓	✓	✓	✓	✓	✓
9184 sc	pH [pH]	Float	✓	✓	✓	✓	✓	✓
9185 sc	Generic tags for SC devices	Integer	—	—	✓	✓	✓	✓
9185 sc	Concentration [mg/L]	Float	✓	✓	✓	✓	✓	✓
9185 sc	Concentration [ppb]	Float	✓	✓	✓	✓	✓	✓
9185 sc	Concentration [ppm]	Float	✓	✓	✓	✓	✓	✓
9185 sc	Concentration [µg/L]	Float	✓	✓	✓	✓	✓	✓
9185 sc	Current [nA]	Float	✓	✓	✓	✓	✓	✓
9185 sc	Current [µA]	Float	✓	✓	✓	✓	✓	✓
9185 sc	Temperature [°C]	Float	✓	✓	✓	✓	✓	✓
9185 sc	Temperature [°F]	Float	✓	✓	✓	✓	✓	✓
9185 sc	pH [pH]	Float	✓	✓	✓	✓	✓	✓
9187 sc	Generic tags for SC devices	Integer	—	—	✓	✓	✓	✓
9187 sc	Concentration [mg/L]	Float	✓	✓	✓	✓	✓	✓
9187 sc	Concentration [ppb]	Float	✓	✓	✓	✓	✓	✓
9187 sc	Concentration [ppm]	Float	✓	✓	✓	✓	✓	✓
9187 sc	Concentration [µg/L]	Float	✓	✓	✓	✓	✓	✓
9187 sc	Current [nA]	Float	✓	✓	✓	✓	✓	✓
9187 sc	Current [µA]	Float	✓	✓	✓	✓	✓	✓
9187 sc	Temperature [°C]	Float	✓	✓	✓	✓	✓	✓
9187 sc	Temperature [°F]	Float	✓	✓	✓	✓	✓	✓
9187 sc	pH [pH]	Float	✓	✓	✓	✓	✓	✓
D3422 (digital) - 3400 sc	Generic tags for SC devices	Integer	—	—	✓	✓	✓	✓
D3422 (digital) - 3400 sc	Conductivity	Float	✓	✓	✓	✓	✓	✓

Device	Name	Type	mA-O	HVR	P-DP	M-TCP	PRN	E/IP
D3422 (digital) - 3400 sc	Resistivity	Float	✓	✓	✓	✓	✓	✓
D3422 (digital) - 3400 sc	Salinity [ppt]	Float	✓	✓	✓	✓	✓	✓
D3422 (digital) - 3400 sc	Temperature [°C]	Float	✓	✓	✓	✓	✓	✓
D3422 (digital) - 3400 sc	Temperature [°F]	Float	✓	✓	✓	✓	✓	✓
D3422 (digital) - 3400 sc	Total Dissolved Solids (TDS)	Float	✓	✓	✓	✓	✓	✓
D3700 sc (analogic) 6120800 (gateway)	Generic tags for SC devices	Integer	—	—	✓	✓	✓	✓
D3700 sc (analogic) 6120800 (gateway)	Concentration [%]	Float	✓	✓	✓	✓	✓	✓
D3700 sc (analogic) 6120800 (gateway)	Total Dissolved Solids (TDS) [ppm]	Float	✓	✓	✓	✓	✓	✓
D3700 sc (analogic) 6120800 (gateway)	Conductivity	Float	✓	✓	✓	✓	✓	✓
D3700 sc (analogic) 6120800 (gateway)	Salinity [ppt]	Float	✓	✓	✓	✓	✓	✓
D3700 sc (analogic) 6120800 (gateway)	Temperature [°C]	Float	✓	✓	✓	✓	✓	✓
D3700 sc (analogic) 6120800 (gateway)	Temperature [°F]	Float	✓	✓	✓	✓	✓	✓
34yyxx (analog) + Gateway (6120700)	Generic tags for SC devices	Integer	—	—	✓	✓	✓	✓
34yyxx (analog) + Gateway (6120700)	Conductivity	Float	✓	✓	✓	✓	✓	✓
34yyxx (analog) + Gateway (6120700)	Resistivity	Float	✓	✓	✓	✓	✓	✓
34yyxx (analog) + Gateway (6120700)	Salinity [ppt]	Float	✓	✓	✓	✓	✓	✓
34yyxx (analog) + Gateway (6120700)	Temperature [°C]	Float	✓	✓	✓	✓	✓	✓
34yyxx (analog) + Gateway (6120700)	Temperature [°F]	Float	✓	✓	✓	✓	✓	✓
34yyxx (analog) + Gateway (6120700)	Total Dissolved Solids (TDS)	Float	✓	✓	✓	✓	✓	✓
pHD (analog) + Gateway (6120500)	Generic tags for SC devices	Integer	—	—	✓	✓	✓	✓
pHD (analog) + Gateway (6120500)	ORP [mV]	Float	✓	✓	✓	✓	✓	✓
pHD (analog) + Gateway (6120500)	Temperature [°C]	Float	✓	✓	✓	✓	✓	✓
pHD (analog) + Gateway (6120500)	Temperature [°F]	Float	✓	✓	✓	✓	✓	✓

Device	Name	Type	mA-O	HVR	P-DP	M-TCP	PRN	E/IP
pHD (analog) + Gateway (6120500)	pH [pH]	Float	✓	✓	✓	✓	✓	✓
RC and PC (analog) + Gateway (6120600)	Generic tags for SC devices	Integer	—	—	✓	✓	✓	✓
RC and PC (analog) + Gateway (6120600)	ORP [mV]	Float	✓	✓	✓	✓	✓	✓
RC and PC (analog) + Gateway (6120600)	Temperature [°C]	Float	✓	✓	✓	✓	✓	✓
RC and PC (analog) + Gateway (6120600)	Temperature [°F]	Float	✓	✓	✓	✓	✓	✓
RC and PC (analog) + Gateway (6120600)	pH [pH]	Float	✓	✓	✓	✓	✓	✓
8362 sc panel pH/ORP V5	Generic tags for SC devices	Integer	—	—	✓	✓	✓	✓
8362 sc panel pH/ORP V5	ORP [mV]	Float	✓	✓	✓	✓	✓	✓
8362 sc panel pH/ORP V5	pH [pH]	Float	✓	✓	✓	✓	✓	✓
8362 sc panel pH/ORP V5	Temperature [°C]	Float	✓	✓	✓	✓	✓	✓
8362 sc panel pH/ORP V5	Temperature [°F]	Float	✓	✓	✓	✓	✓	✓

Device	Name	Type	mA-O	HVR	P-DP	M-TCP	PRN	E/IP
RTC-DAF	Generic tags for SC devices	Integer	—	—	✓	✓	✓	✓
RTC-DAF	Coagulant set point	Float	✓	✓	✓	✓	✓	✓
RTC-DAF	Flocculant set point	Float	✓	✓	✓	✓	✓	✓
RTC-DAF	Coagulant concentration	Float	✓	✓	✓	✓	✓	✓
RTC-DAF	Coagulant dosing factor	Float	✓	✓	✓	✓	✓	✓
RTC-DAF	Flocculant concentration	Float	✓	✓	✓	✓	✓	✓
RTC-DAF	Flocculant dosing factor	Float	✓	✓	✓	✓	✓	✓
RTC-DAF	Coagulant pump ON/OFF	Float	✓	✓	✓	✓	✓	✓
RTC-DAF	Flocculant pump ON/OFF	Float	✓	✓	✓	✓	✓	✓
RTC-DAF	pH chemical set point	Float	✓	✓	✓	✓	✓	✓
RTC-DAF	pH dosing pump ON/OFF	Float	✓	✓	✓	✓	✓	✓
RTC-DAF	TSS clear set point	Float	✓	✓	✓	✓	✓	✓
RTC-DAF	TSS clear measured	Float	✓	✓	✓	✓	✓	✓
RTC-DAF	pH set point	Float	✓	✓	✓	✓	✓	✓
RTC-DAF	pH measured	Float	✓	✓	✓	✓	✓	✓
RTC-DAF	Feed flow set point	Float	✓	✓	✓	✓	✓	✓
RTC-DAF	Feed flowrate measured	Float	✓	✓	✓	✓	✓	✓

Device	Name	Type	mA-O	HVR	P-DP	M-TCP	PRN	E/IP
RTC-DAF	TSS feed measured	Float	✓	✓	✓	✓	✓	✓
RTC-DAF	Coagulant flow measured	Float	✓	✓	✓	✓	✓	✓
RTC-DAF	Flocculant flow measured	Float	✓	✓	✓	✓	✓	✓
RTC-DAF	pH chemical flowrate measured	Float	✓	✓	✓	✓	✓	✓
RTC-DAF	Generic Spare 01	Float	✓	✓	✓	✓	✓	✓
RTC-DAF	Generic Spare 02	Float	✓	✓	✓	✓	✓	✓
RTC-DAF	Generic Spare 03	Float	✓	✓	✓	✓	✓	✓
RTC-DAF	Generic Spare 04	Float	✓	✓	✓	✓	✓	✓
RTC-DAF	Generic Spare 05	Float	✓	✓	✓	✓	✓	✓
RTC-DAF	Generic Spare 06	Float	✓	✓	✓	✓	✓	✓
RTC-DAF	Generic Spare 07	Float	✓	✓	✓	✓	✓	✓
RTC-DAF	Generic Spare 08	Float	✓	✓	✓	✓	✓	✓
RTC-DAF	Generic Spare 09	Float	✓	✓	✓	✓	✓	✓
RTC-DAF	Generic Spare 10	Float	✓	✓	✓	✓	✓	✓
RTC-DAF	Generic Spare 11	Float	✓	✓	✓	✓	✓	✓
RTC-DAF	Generic Spare 12	Float	✓	✓	✓	✓	✓	✓
RTC-DAF	Generic Spare 13	Float	✓	✓	✓	✓	✓	✓
RTC-DAF	Generic Spare 14	Float	✓	✓	✓	✓	✓	✓
RTC-DAF	Generic Spare 15	Float	✓	✓	✓	✓	✓	✓
RTC-DAF	Generic Spare 16	Float	✓	✓	✓	✓	✓	✓
RTC-N/DN	DO setpoint	Float	✓	✓	✓	✓	✓	✓
RTC-N/DN	Aeration stage	Float	✓	✓	✓	✓	✓	✓
RTC-N/DN	Aeration intensity 1 (ratio)	Float	✓	✓	✓	✓	✓	✓
RTC-N/DN	Aeration intensity 2 (ratio)	Float	✓	✓	✓	✓	✓	✓
RTC-N/DN	DO	Float	✓	✓	✓	✓	✓	✓
RTC-N/DN	ORP	Float	✓	✓	✓	✓	✓	✓
RTC-N/DN	NH ₄ -N	Float	✓	✓	✓	✓	✓	✓
RTC-N/DN	NO ₃ -N	Float	✓	✓	✓	✓	✓	✓
RTC-N/DN	Nitrogen control, computed	Float	✓	✓	✓	✓	✓	✓
RTC-N/DN	DO control, computed	Float	✓	✓	✓	✓	✓	✓
RTC-N/DN	Flow, averaged	Float	✓	✓	✓	✓	✓	✓
RTC-N/DN	Threshold, analog value	Float	✓	✓	✓	✓	✓	✓
RTC-N/DN	Process Approval	Float	✓	✓	✓	✓	✓	✓
RTC-N/DN	Flow	Float	✓	✓	✓	✓	✓	✓
RTC-N/DN	Generic Spare 01	Float	✓	✓	✓	✓	✓	✓
RTC-N/DN	Generic Spare 02	Float	✓	✓	✓	✓	✓	✓

Device	Name	Type	mA-O	HVR	P-DP	M-TCP	PRN	E/IP
RTC-N/DN	Generic Spare 03	Float	✓	✓	✓	✓	✓	✓
RTC-N/DN	Generic Spare 04	Float	✓	✓	✓	✓	✓	✓
RTC-N/DN	Generic Spare 05	Float	✓	✓	✓	✓	✓	✓
RTC-N/DN	Generic Spare 06	Float	✓	✓	✓	✓	✓	✓
RTC-N/DN	Generic Spare 07	Float	✓	✓	✓	✓	✓	✓
RTC-N/DN	Generic Spare 08	Float	✓	✓	✓	✓	✓	✓
RTC-N/DN	Generic Spare 09	Float	✓	✓	✓	✓	✓	✓
RTC-N/DN	Generic Spare 10	Float	✓	✓	✓	✓	✓	✓
RTC-N/DN	Generic Spare 11	Float	✓	✓	✓	✓	✓	✓
RTC-N/DN	Generic Spare 12	Float	✓	✓	✓	✓	✓	✓
RTC-N/DN	Generic Spare 13	Float	✓	✓	✓	✓	✓	✓
RTC-N/DN	Generic Spare 14	Float	✓	✓	✓	✓	✓	✓
RTC-N/DN	Generic Spare 15	Float	✓	✓	✓	✓	✓	✓
RTC-N/DN	Generic Spare 16	Float	✓	✓	✓	✓	✓	✓
RTC-N/DN	Generic tags for SC devices	Integer	—	—	✓	✓	✓	✓
RTC-P	Dosing Rate applied	Float	✓	✓	✓	✓	✓	✓
RTC-P	Dosing pump ON/OFF	Float	✓	✓	✓	✓	✓	✓
RTC-P	Dosing Rate calculated	Float	✓	✓	✓	✓	✓	✓
RTC-P	Beta value	Float	✓	✓	✓	✓	✓	✓
RTC-P	Set point PO4-P	Float	✓	✓	✓	✓	✓	✓
RTC-P	PO ₄ -P measured	Float	✓	✓	✓	✓	✓	✓
RTC-P	Qdosing	Float	✓	✓	✓	✓	✓	✓
RTC-P	Qinflow	Float	✓	✓	✓	✓	✓	✓
RTC-P	Q_RAS	Float	✓	✓	✓	✓	✓	✓
RTC-P	PO4-P_eff	Float	✓	✓	✓	✓	✓	✓
RTC-P	PO ₄ -P_FB	Float	✓	✓	✓	✓	✓	✓
RTC-P	PO ₄ -P_FF	Float	✓	✓	✓	✓	✓	✓
RTC-P	PO ₄ -Pout	Float	✓	✓	✓	✓	✓	✓
RTC-P	Fe	Float	✓	✓	✓	✓	✓	✓
RTC-P	Stage	Float	✓	✓	✓	✓	✓	✓
RTC-P	SBR Level	Float	✓	✓	✓	✓	✓	✓
RTC-P	Qras	Float	✓	✓	✓	✓	✓	✓
RTC-P	Qin	Float	✓	✓	✓	✓	✓	✓
RTC-P	IRC flow	Float	✓	✓	✓	✓	✓	✓
RTC-P	Generic Spare 01	Float	✓	✓	✓	✓	✓	✓
RTC-P	Generic Spare 02	Float	✓	✓	✓	✓	✓	✓

Device	Name	Type	mA-O	HVR	P-DP	M-TCP	PRN	E/IP
RTC-P	Generic Spare 03	Float	✓	✓	✓	✓	✓	✓
RTC-P	Generic Spare 04	Float	✓	✓	✓	✓	✓	✓
RTC-P	Generic Spare 05	Float	✓	✓	✓	✓	✓	✓
RTC-P	Generic Spare 06	Float	✓	✓	✓	✓	✓	✓
RTC-P	Generic Spare 07	Float	✓	✓	✓	✓	✓	✓
RTC-P	Generic Spare 08	Float	✓	✓	✓	✓	✓	✓
RTC-P	Generic Spare 09	Float	✓	✓	✓	✓	✓	✓
RTC-P	Generic Spare 10	Float	✓	✓	✓	✓	✓	✓
RTC-P	Generic Spare 11	Float	✓	✓	✓	✓	✓	✓
RTC-P	Generic Spare 12	Float	✓	✓	✓	✓	✓	✓
RTC-P	Generic Spare 13	Float	✓	✓	✓	✓	✓	✓
RTC-P	Generic Spare 14	Float	✓	✓	✓	✓	✓	✓
RTC-P	Generic Spare 15	Float	✓	✓	✓	✓	✓	✓
RTC-P	Generic Spare 16	Float	✓	✓	✓	✓	✓	✓
RTC-P	Generic tags for SC devices	Integer	—	—	✓	✓	✓	✓
RTC-SP	Dosing concentration	Float	✓	✓	✓	✓	✓	✓
RTC-SP	Port	Float	✓	✓	✓	✓	✓	✓
RTC-SP	Dosing pump ON/OFF	Integer	✓	✓	✓	✓	✓	✓
RTC-SP	Dosing rate	Float	✓	✓	✓	✓	✓	✓
RTC-SP	Feed flowrate	Float	✓	✓	✓	✓	✓	✓
RTC-SP	Set point TSS	Float	✓	✓	✓	✓	✓	✓
RTC-SP	TSS thickened	Float	✓	✓	✓	✓	✓	✓
RTC-SP	TSS clear	Float	✓	✓	✓	✓	✓	✓
RTC-SP	TSS feed	Float	✓	✓	✓	✓	✓	✓
RTC-SP	Feed flowrate measured	Float	✓	✓	✓	✓	✓	✓
RTC-SP	Polyflow measured	Float	✓	✓	✓	✓	✓	✓
RTC-SP	Process Approval	Integer	✓	✓	✓	✓	✓	✓
RTC-SP	Generic Spare 01	Float	✓	✓	✓	✓	✓	✓
RTC-SP	Generic Spare 02	Float	✓	✓	✓	✓	✓	✓
RTC-SP	Generic Spare 03	Float	✓	✓	✓	✓	✓	✓
RTC-SP	Generic Spare 04	Float	✓	✓	✓	✓	✓	✓
RTC-SP	Generic Spare 05	Float	✓	✓	✓	✓	✓	✓
RTC-SP	Generic Spare 06	Float	✓	✓	✓	✓	✓	✓
RTC-SP	Generic Spare 07	Float	✓	✓	✓	✓	✓	✓
RTC-SP	Generic Spare 08	Float	✓	✓	✓	✓	✓	✓
RTC-SP	Generic Spare 09	Float	✓	✓	✓	✓	✓	✓

Device	Name	Type	mA-O	HVR	P-DP	M-TCP	PRN	E/IP
RTC-SP	Generic Spare 10	Float	✓	✓	✓	✓	✓	✓
RTC-SP	Generic Spare 11	Float	✓	✓	✓	✓	✓	✓
RTC-SP	Generic Spare 12	Float	✓	✓	✓	✓	✓	✓
RTC-SP	Generic Spare 13	Float	✓	✓	✓	✓	✓	✓
RTC-SP	Generic Spare 14	Float	✓	✓	✓	✓	✓	✓
RTC-SP	Generic Spare 15	Float	✓	✓	✓	✓	✓	✓
RTC-SP	Generic Spare 16	Float	✓	✓	✓	✓	✓	✓
RTC-SP	Generic tags for SC devices	Integer	—	—	✓	✓	✓	✓

Appendix B Open-source code and licenses

The open-source code used in the device can be found at <https://github.com/HachCompany-SC4500>.

Instructions on how to build the device can be found at https://github.com/HachCompany-SC4500/fusion_seacloud_platform.

The related open-source licenses can be found at https://github.com/HachCompany-SC4500/fusion_licenses.



HACH COMPANY World Headquarters

P.O. Box 389, Loveland, CO 80539-0389 U.S.A.
Tel. (970) 669-3050
(800) 227-4224 (U.S.A. only)
Fax (970) 669-2932
orders@hach.com
www.hach.com

HACH LANGE GMBH

Willstätterstraße 11
D-40549 Düsseldorf, Germany
Tel. +49 (0) 2 11 52 88-320
Fax +49 (0) 2 11 52 88-210
info-de@hach.com
www.de.hach.com

HACH LANGE Sàrl

6, route de Compois
1222 Vézenaz
SWITZERLAND
Tel. +41 22 594 6400
Fax +41 22 594 6499