

OPERATING MANUAL

AccuZone™53 Dissolved Ozone Measurement System

(Universal-mount 1/2 DIN style analyzer)

Worldwide Headquarters and Sales:

GLI International, Inc. *Phone:* [414] 355-3601
9020 West Dean Road *Fax:* [414] 355-8346
Milwaukee, Wisconsin 53224 *E-mail:* info@gliint.com
U.S.A. *Web:* www.gliint.com

Represented By:

In the interest of improving and updating its equipment, GLI reserves the right to alter specifications to equipment at any time.
A **Viridor Instrumentation** company

gliint.com

This operating manual and other GLI operating manuals are available on GLI's web site at gliint.com. when viewed using Adobe's free Acrobat reader. To get this reader, link to Adobe through GLI's web site or visit Adobe's web site at adobe.com.

IMPORTANT SAFETY INFORMATION

This analyzer is compliant with safety standards as outlined in:

FMRC Class Numbers 3600, 3611, and 3810 (U.S.A.)
CSA C22.2 No. 142 and C22.2 No. 213 (Canada)
EN 61010-1 (European Community)

Please read and observe the following:

- Opening the analyzer door exposes you to line power voltage, if present, at terminals on TB2 and TB3 inside the enclosure. This may be hazardous. Always remove line power before entering this area in the analyzer. However, the analyzer door assembly contains only low voltage and is completely safe to handle.
- Wiring or repairs should only be performed by qualified personnel and only to an unpowered analyzer.
- Whenever it appears that analyzer safety is questionable, disable the analyzer to ensure against any unintended operation. For example, an unsafe condition is likely when:
 - 1) The analyzer appears visibly damaged.
 - 2) The analyzer fails to operate properly or provide the intended measurements.
 - 3) The analyzer has been stored for long periods at temperatures above 158°F (70°C).
- This measurement system must be installed in accordance with relevant local codes and instructions contained in this operating manual. Observe all technical specifications of the system. If one line of the line power mains is not neutral, use a double-pole mains switch to disconnect the analyzer.

HELPFUL IDENTIFIERS

In addition to information on installation and operation, this instruction manual may contain WARNINGS pertaining to user safety, CAUTIONS regarding possible instrument malfunction, and NOTES on important, useful operating guidelines.

WARNING:

A WARNING LOOKS LIKE THIS. IT WARNS YOU OF THE POTENTIAL FOR PERSONAL INJURY.

CAUTION:

A CAUTION LOOKS LIKE THIS. IT ALERTS YOU TO POSSIBLE INSTRUMENT MALFUNCTION OR DAMAGE.

 **NOTE:** A note looks like this. It alerts you to important, useful operating information.

Definition of Equipment Symbols



This symbol **means CAUTION** and alerts you to possible danger or instrument malfunction. Refer to this manual before proceeding.



This symbol **means that this is a protective ground terminal** and alerts you to connect an earth ground to it.



This symbol **means that there is alternating current present** and alerts you to be careful.

WARRANTY

GLI International, Inc. warrants the AccuZone™53 Ozone Measurement System to be free from defects in material or workmanship for a period of 2 years (24 months) from the date of shipment of this product from our facility. A warranty claim will not be honored if defects are not reported within the warranty period, or if GLI International determines that defects or damages are due to normal wear, misapplication, lack of maintenance, abuse, improper installation, alteration, or abnormal conditions. GLI International's obligation under this warranty shall be limited to, at its option, replacement or repair of this product. The product must be returned to GLI International, freight prepaid, for examination. The product must be thoroughly cleaned and any process chemicals removed before it will be accepted for replacement or repair. GLI International's liability shall not exceed the cost of the product. Under no circumstances will GLI International be liable for any incidental or consequential damages, whether to person or property. GLI International will not be liable for any other loss, damage or expense of any kind, including loss of profits, resulting from the installation, use, or inability to use this product.

CONDENSED OPERATING INSTRUCTIONS

This manual contains details for all operating aspects of the instrument. The following condensed instructions are provided to assist you in getting the instrument started up and operating as quickly as possible. **These condensed instructions are only for basic ozone measurement operation.** To use specific features of the instrument, refer to the appropriate sections in this manual for instructions.

A. CONNECTING SENSOR

1. Refer to PART TWO, Section 2.2 for details to prepare the GLI Model 5920Z0 ozone sensor for its first use. Then refer to PART TWO, Section 2.3 for details to install the sensor.
2. Properly mount the analyzer. Refer to PART TWO, Section 2.4 for details.
3. Connect sensor cable wires to analyzer "SENSOR" terminals on TB1, matching colors as indicated:

Sensor Wire Colors	Connect to Analyzer
Red (anode)	Terminal #10 on TB1
White (temperature)	Terminal #11 on TB1
Gray (temperature)	Terminal #12 on TB1
Yellow (ground)	Terminal #13 on TB1
Blue (cathode)	Terminal #14 on TB1

B. CONFIGURING SENSOR TEMPERATURE ELEMENT

The analyzer is supplied factory-set for automatic temperature compensation using the NTC 100K ohm temperature element built into the GLI Model 5920Z0 ozone sensor. For fixed manual temperature compensation, you must change the temperature element type to "MANUAL" (see PART THREE, Section 4.2, subheading "Select TEMP ELEMENT Type") and enter a temperature.

C. CONNECTING LINE POWER

Important: Follow the instructions in PART TWO, Section 3.5 to connect line power to the analyzer.

D. ADJUSTING DISPLAY CONTRAST

Ambient lighting conditions may make it necessary to adjust display contrast to improve visibility. With the MEASURE screen displayed, press and hold the **ENTER key** and simultaneously press the **↑ or ↓ key** until attaining the desired contrast.

E. SETTING OZONE MEASUREMENT READOUT

Measured ozone concentration values can be shown in as XX.XX ppm (default) or X.XXX ppm. The third digit to the right of the decimal in the X.XXX format is only operational down to 0.010 ppm.

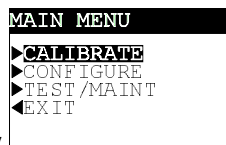

1. Press **MENU key** to display .

(continued on next page)

CONDENSED OPERATING INSTRUCTIONS

E. SETTING OZONE MEASUREMENT READOUT -- (continued)

```
CONFIGURE
▶SET OUTPUT 1
▶SET OUTPUT 2
▶SET RELAY A
▶SET RELAY B
▶SET RELAY C
▶SET RELAY D
▶SET PASSCODE
▶SET °C OR °F
▶LANGUAGE
▶SENSOR
◀EXIT
```

- Use **↓ key** to select "CONFIGURE" line, and press **ENTER key** to display

```
SENSOR
▶DISPLAY FORMAT
▶SET FILTER
▶PULSE SUPPRESS
▶ENTER NOTE
▶TEMP ELEMENT
◀EXIT
```

- Use **↓ key** to select "SENSOR" line, and press **ENTER key** to display

- Press **ENTER key** to display a screen like

DISPLAY FORMAT?
(XX.XX ppm)

. Use **↓ and ↑ keys** to view both choices (XX.XX ppm or X.XXX ppm). With the desired choice displayed, press **ENTER key** to enter this selection.

F. CALIBRATING THE SYSTEM

The system must be calibrated for ozone concentration so that measured values will correspond to actual process values. The SAMPLE CAL method, described below, enables you to keep the sensor in the process, or place the sensor in a container holding a sample of the process. In either case, determine the value of the process (or sample) by laboratory analysis or a comparison reading. Then enter the known ozone value.

Calibration Tip! If at any time during calibration, the "CONFIRM FAILURE?" screen appears, press **ENTER key** to confirm. Then, use the **↑ or ↓ key** to select between "CAL: EXIT" or "CAL: REPEAT" and do one of the following:

- With the "(CAL: EXIT)" screen selected, press **ENTER key**. Then, after the "CONFIRM ACTIVE?" screen appears, press **ENTER key** to return the analog outputs and relays to their active states (MEASURE screen appears).
- With the "(CAL REPEAT)" screen selected, press **ENTER key** to repeat calibration.

- Keep the sensor in the process or immerse the sensor in a sample. **Allow the sensor and process (or sample) temperatures to equalize.** Depending on their temperature differences, this may take 30 minutes or more.

```
MAIN MENU
▶CALIBRATE
▶CONFIGURE
▶TEST/MAINT
◀EXIT
```

- Press **MENU key** to display

(continued on next page)

CONDENSED OPERATING INSTRUCTIONS

F. CALIBRATING THE SYSTEM -- (continued)

3. With the "CALIBRATE" line selected, press **ENTER key** to display

```
CALIBRATE
▶SENSOR
▶TEMPERATURE
▶CAL OUTPUTS
◀EXIT
```

4. With the "SENSOR" line selected, press **ENTER key** to display

```
SENSOR
▶SAMPLE CAL
◀EXIT
```

5. With the "SAMPLE CAL" line selected, press **ENTER key** to display

```
SAMPLE CAL?
(HOLD OUTPUTS )
```

. Press **ENTER key** to "hold" the analog outputs and relays at their present states during calibration. (Outputs can also be transferred to user-preset values or allowed to remain active.)

6. With the sensor in the process (or sample) and the

```
XX.XX ppm
SAMPLE READY?
```

 screen showing the active measurement reading, press **ENTER key** to confirm. The "SAMPLE CAL PLEASE WAIT" screen appears, enabling ozone and temperature signals to stabilize. This may take several minutes.

7. After the reading has stabilized, this static

```
SAMPLE CAL?
(XX.XX ppm )
```

 screen appears showing the "last measured" value.

NOTE: If this screen reads zero, verify that ozone is present. If yes, check to make sure that sensor wiring is correct and intact. If it is, the sensor needs servicing (see PART FOUR, Section 3). When a sensor, even a new sensor, has been inactive for more than 6 weeks, its electrodes begin to tarnish due to lack of operational electrochemical activity, contaminating the electrolyte. For prolonged storage, always store the sensor in a "dry" condition (see PART FOUR, Section 4).

8. Use **arrow keys** to adjust the displayed value to exactly match the known ozone value.
9. Press **ENTER key** to enter the value and complete calibration (CONFIRM CAL OK? screen appears).
10. If using a container of process sample, re-install the sensor into the process.
11. Press **ENTER key** to display the active measurement reading on the "CONFIRM ACTIVE?" output status screen. When the reading corresponds to the actual typical process value, press **ENTER key** again to return the analog outputs and relays to their active states (MEASURE screen appears).

This completes calibration. The system is now ready to accurately measure ozone concentration.

G. COMPLETING SYSTEM CONFIGURATION

To further configure the system to your application requirements, use the appropriate CONFIGURE screens to make selections and "key in" values. Refer to PART THREE, Section 4 for complete configuration details.

TABLE OF CONTENTS

PART ONE - INTRODUCTION

SECTION 1	GENERAL INFORMATION	
	1.1 Capability Highlights	15-17
	1.2 Modular Construction	17
	1.3 Retained Configuration Values	17
	1.4 Analyzer and Sensor Serial Numbers	17
	1.5 EMI/RFI Immunity	18
SECTION 2	SPECIFICATIONS	19-20

PART TWO - INSTALLATION

SECTION 1	UNPACKING	21
SECTION 2	MECHANICAL REQUIREMENTS	
	2.1 Sensor/Analyzer Location	21
	2.2 Sensor Preparation for First Use.....	22
	2.3 Sensor Mounting	23
	2.4 Analyzer Mounting.....	24-25
	2.5 Conduit Hole Requirements	25
SECTION 3	ELECTRICAL CONNECTIONS	
	3.1 Ozone Sensor	27-28
	3.2 Analog Outputs.....	29
	3.3 Relay Outputs.....	30
	3.4 Closed Contact TTL Input	31
	3.5 Line Power	31-32

PART THREE - OPERATION

SECTION 1	USER INTERFACE	
	1.1 Display	33
	1.2 Keypad	33-34
	1.3 MEASURE Screen (normal display mode)	35
SECTION 2	MENU STRUCTURE	
	2.1 Displaying Main Branch Selection Screen	36
	2.2 Displaying Top-level Menu Screens.....	36-37
	2.3 Displaying Submenu Screens	37
	2.4 Adjusting Edit/Selection Screen Values	37
	2.5 Entering (Storing) Edit/Selection Screen Values/Choices.....	37

TABLE OF CONTENTS (continued)

SECTION 3	ADJUSTING DISPLAY CONTRAST	38
SECTION 4	ANALYZER CONFIGURATION	
4.1	Selecting LANGUAGE to Operate Analyzer.....	38
4.2	Configuring Sensor Characteristics:	
	Select DISPLAY FORMAT (XX.XX ppm or X.XXX ppm).....	39
	SET FILTER Time.....	39-40
	Select PULSE SUPPRESS (on or off)	40
	ENTER NOTE (top line of MEASURE screen).....	40-41
	Select TEMP ELEMENT Type	41-42
4.3	SET °C or °F (temperature display).....	42
4.4	Configuring Analog Outputs (1 and 2):	
	SET PARAMETER (representation)	43-44
	SET 0/4 and 20 mA VALUES.....	44-45
	SET TRANSFER Value (mA)	45
	SET FILTER Time.....	45-46
	Select SCALE 0 mA/4 mA (low endpoint)	46
4.5	Configuring Relays (A, B, C, and D):	
	SET PARAMETER (representation)	46-47
	SET FUNCTION Mode (alarm, control, status or timer).....	48-49
	SET TRANSFER Mode (relay on or off)	49
	ACTIVATION (configuration values).....	49-51
4.6	SET PASSCODE (feature enabled or disabled)	52
4.7	Configuration Setting Summary (ranges/choices and defaults)	53-54
SECTION 5	ANALYZER CALIBRATION	
5.1	Important Information	55-56
5.2	Ozone SAMPLE CAL Calibration	56-57
5.3	Temperature Calibration:	
	1 POINT SAMPLE Method.....	58-59
	2 POINT SAMPLE Method.....	59-61
5.4	Analog Outputs (1 and 2) Calibration.....	62-63
SECTION 6	TEST/MAINTENANCE	
6.1	STATUS Checking (analyzer, sensor, and relays).....	64-65
6.2	SENSOR AIR TEST	66-67
6.3	HOLD OUTPUTS	68
6.4	OVERFEED RESET (relay timers).....	68-69
6.5	OUTPUT (1 and 2) Analog Test Signals	69
6.6	RELAY (A, B, C, and D) Operating Test.....	69-70
6.7	EPROM VERSION Checking	70
6.8	SELECT SIM Measurement	70-71
6.9	SIM SENSOR Setting.....	71

TABLE OF CONTENTS (continued)

	6.10 RESET CONFIGURE Values to Factory Defaults.....	71-72
	6.11 RESET CALIBRATE Values to Factory Defaults	72
SECTION 7	RELAY OVERFEED TIMER FEATURE	
	7.1 Why Use an Overfeed Timer.....	73
	7.2 Configuring Relay Overfeed Timers.....	73
	7.3 Overfeed Timer “Timeout” Operation	73
	7.4 Resetting Overfeed Timers	73
	7.5 Interactions with Other Analyzer Functions.....	73-74
SECTION 8	HART OPTION	
	8.1 Introduction	75
	8.2 Analyzer Operating Modes for HART Network.....	76-77
	8.3 SINGLE MODE (Point-to-Point) Wiring Arrangement	77
	8.4 MULTI-DROP Wiring Arrangement	78
	8.5 HART Preferences Setup:	
	Changing Polling Address	79
	Viewing Number of Required Preambles	79-80
	8.6 Device Preferences Setup:	
	Viewing Final Assembly Number	80
	Viewing Model Number	80-81
	Viewing Manufacturer	81
	Assigning a Tag	81
	Assigning a Descriptor	82
	Assigning a Message	82
	Assigning User-defined Date	82-83
	Viewing Identification (ID)	83
	Viewing Revisions.....	83
	8.7 “Master Reset” Function.....	84
	8.8 “Refresh” Function	84
	8.9 Protocol Command Set for PC Programming.....	84

PART FOUR - SERVICE AND MAINTENANCE

SECTION 1	GENERAL INFORMATION	
	1.1 Inspecting Sensor Cable	85
	1.2 Replacing Analyzer Fuse(s)	85
	1.3 Replacing Analyzer Relays	85
SECTION 2	PRESERVING MEASUREMENT ACCURACY	
	2.1 Keeping Sensor Clean	86
	2.2 Keeping Analyzer Calibrated.....	86
	2.3 Avoiding Electrical Interference.....	86

TABLE OF CONTENTS (continued)

SECTION 3	SERVICING SENSOR	
	3.1 When to Service Sensor	87
	3.2 Removing Sensor from Sample Line	87
	3.3 Preparing Sensor for Cleaning	87-89
	3.4 Chemical Cleaning:	
	Ammonium Hydroxide Cleaning	90
	Nitric Acid Cleaning (optional)	90-91
	3.5 Polishing Sensor Face	91-93
	3.6 Final Electrode Cleaning	93-94
	3.7 Replacing Membrane	94-97
	3.8 Placing Sensor Back into Operation	97-98
SECTION 4	STORING SENSOR	98
SECTION 5	TROUBLESHOOTING	
	5.1 Ground Loops:	
	Determining if Ground Loop Exists	99
	Finding Source of Ground Loop	100
	5.2 Isolating Measuring System Problem:	
	Checking Electrical Connections	100
	Verifying Sensor Operation	100
SECTION 6	ANALYZER REPAIR/RETURN	
	6.1 Customer Assistance	101
	6.2 Repair/Return Policy	101

PART FIVE - SPARE PARTS AND ACCESSORIES

 102-103
--	---------------

ILLUSTRATIONS

Figure 1-1	EMI/RFI Immunity Diagram	18
Figure 2-1	Basic Sensor Components	22
Figure 2-2	Union Mount Sensor Installation Dimensions	23
Figure 2-3	Analyzer Mounting Arrangements	24
Figure 2-4	Analyzer Installation Dimension Details	25

TABLE OF CONTENTS (continued)

ILLUSTRATIONS (continued)

Figure 2-5	Analyzer Terminal Designations.....	27
Figure 2-6	Connecting Ozone Sensor	28
Figure 2-7	Connecting Control/Alarm Device(s) to Electromechanical Relay(s).....	30
Figure 2-8	Connecting 115 Volt Single Phase Line Power (90-130 VAC).....	32
Figure 2-9	Connecting 230 Volt Single Phase Line Power (180-260 VAC).....	32
Figure 2-10	Connecting 230 Volt Split Phase Line Power (180-260 VAC).....	32
Figure 3-1	Analyzer Keypad.....	34
Figure 3-2	Location of SINGLE MODE/MULTI-DROP Switch (HART-equipped analyzers only)	77
Figure 3-3	HART SINGLE MODE (Point-to-Point) Wiring Arrangement (for single analyzer).....	77
Figure 3-4	HART MULTI-DROP Wiring Arrangement (for multiple analyzer network).....	78
Figure 4-1	Removing Sensor Protection Cap	87
Figure 4-2	Sensor Membrane Assembly Components -- Exploded View	88
Figure 4-3	Removing Membrane Holding Ring.....	88
Figure 4-4	Removing Membrane Support	89
Figure 4-5	Cleaning Anode with Nitric Acid	91
Figure 4-6	Replacing Membrane Support.....	91
Figure 4-7	Mixing Polishing Powder with Water on Polishing Cloth	92
Figure 4-8	Polishing Sensor Face with Circular Motion.....	92
Figure 4-9	Cleaning Groove Between Cathode and Guard Ring Electrode	93
Figure 4-10	Cleaning Gold Cathode with Nitric Acid.....	94
Figure 4-11	Filling Sensor with Electrolyte	94
Figure 4-12	Placing Guide on Sensor.....	95
Figure 4-13	Placing Membrane on Sensor Face	95
Figure 4-14	Placing Membrane Holding Ring on Plunger	96
Figure 4-15	Inserting Plunger into Guide.....	96
Figure 4-16	Completing Membrane Mounting	96
Figure 4-17	Replacing Protection Cap.....	98
Figure 5-1	Sensor Component Spare Parts -- Exploded View	103

TABLES

Table A	Relay Configuration Settings.....	50
Table B	Analyzer Configuration Settings (Ranges/Choices and Defaults).....	53-54
Table C	Relay Overfeed Timer Interactions with Other Analyzer Functions.....	74

PART ONE - INTRODUCTION

SECTION 1

GENERAL INFORMATION

1.1 Capability Highlights

Sensor Input

The analyzer must be used with a GLI Model 5920Z0 ozone sensor. These sensors have a built-in NTC 100K ohm thermistor that automatically compensates the ozone concentration measurement for temperature changes, and provides process temperature readings.

MEASURE Screen (normal display mode)

With the display in the normal MEASURE screen mode, the measured ozone is always shown on the main middle line. The bottom auxiliary display line, shown in reverse video, can be changed by pressing the \downarrow **and** \uparrow **keys** to show these other measurements:

- Measured temperature (°C or °F)
- Analog Output 1 value (mA)
- Analog Output 2 value (mA)

Passcode-protected Access

For security, you can enable a passcode feature to restrict access to configuration and calibration settings to authorized personnel only. See PART THREE, Section 4.6 for details.

Calibration Methods

The “SAMPLE CAL” method is provided for ozone calibration. It requires immersing the sensor in the process (or a sample), determining the ozone value by laboratory analysis or a comparison reading from a calibrated ozone concentration instrument, and entering the known value. See PART THREE, Section 5.2 for more details.

The analyzer also has two temperature calibration methods (Section 5.3) which are typically not needed since the analyzer is factory-calibrated for highly accurate temperature measurement. The mA values for each analog output can also be calibrated (Section 5.4).

Analog Outputs

The analyzer provides two isolated analog outputs (1 and 2). Each output can be set to be 0-20 mA or 4-20 mA, and assigned to represent one of the following:

- Measured ozone
- Measured temperature.

Ozone (or temperature) values can be entered to define the endpoints at which the minimum and maximum analog output values are desired (range expand). For analog output setup details, refer to PART THREE, Section 4.4.

During calibration, both analog outputs can be selected to:

- Hold their present values (HOLD OUTPUTS)
- Transfer to preset values to operate control elements by an amount corresponding to those values (XFER OUTPUTS)
- Remain active to respond to the measured value (ACTIVE OUTPUTS).

Relays

The analyzer has up to four electromechanical relays, all with SPDT contacts. Each relay can be set to function as a CONTROL, ALARM, STATUS or TIMER relay. CONTROL and ALARM relays can be assigned to be driven by one of these:

- Measured ozone
- Measured temperature.



NOTE: *Since TIMER and STATUS function relays are driven by other criteria, the parameter assigned to these relays is not relevant and, therefore, disregarded.*

Also, when a relay is set to function as a STATUS relay, it is no longer configurable. Instead, it becomes a dedicated system diagnostic-only alarm relay that automatically energizes when the "WARNING CHECK STATUS" message flashes on the MEASURE screen. This occurs when the analyzer detects a "fail" diagnostic condition. See PART THREE, Section 6.1 for more details.

Except for STATUS relays, during calibration the relay on/off states are affected in the same way as the analog outputs by the “(HOLD/XFER/ACTIVE) OUTPUTS” screen selection. These relays are also held at their present on/off states, transferred to desired user-preset on/off states, or remain active to respond to measured values.

Refer to PART THREE, Section 4.5 for relay setup details.

1.2 Modular Construction

The modular construction of the analyzer simplifies field servicing and provides electrical safety. The front door/keypad assembly uses voltages no greater than 24 VDC, and is completely safe to handle.

Opening the analyzer door accesses terminals inside the enclosure for electrical connections. Line power must be connected to specifically designated terminals on TB3.

WARNING:

REMOVE LINE POWER BEFORE NEARING THIS AREA TO AVOID ELECTRICAL SHOCK.

1.3 Retained Configuration Values

All user-entered configuration values are retained indefinitely, even if power is lost or turned off. The non-volatile analyzer memory does not require battery backup.

1.4 Analyzer and Sensor Serial Numbers

A label with the analyzer model number, serial number, build date, and other items is affixed to the top of the enclosure. The sensor model number and serial number are identified on the sensor body.

1.5 EM/RFI Immunity

The analyzer is designed to provide protection from most normally encountered electromagnetic interference. This protection exceeds US standards and meets European IEC 801-series testing for electromagnetic and radio frequency emissions and susceptibility. Refer to Figure 1-1 and the specifications in Section 2.2 for more information.

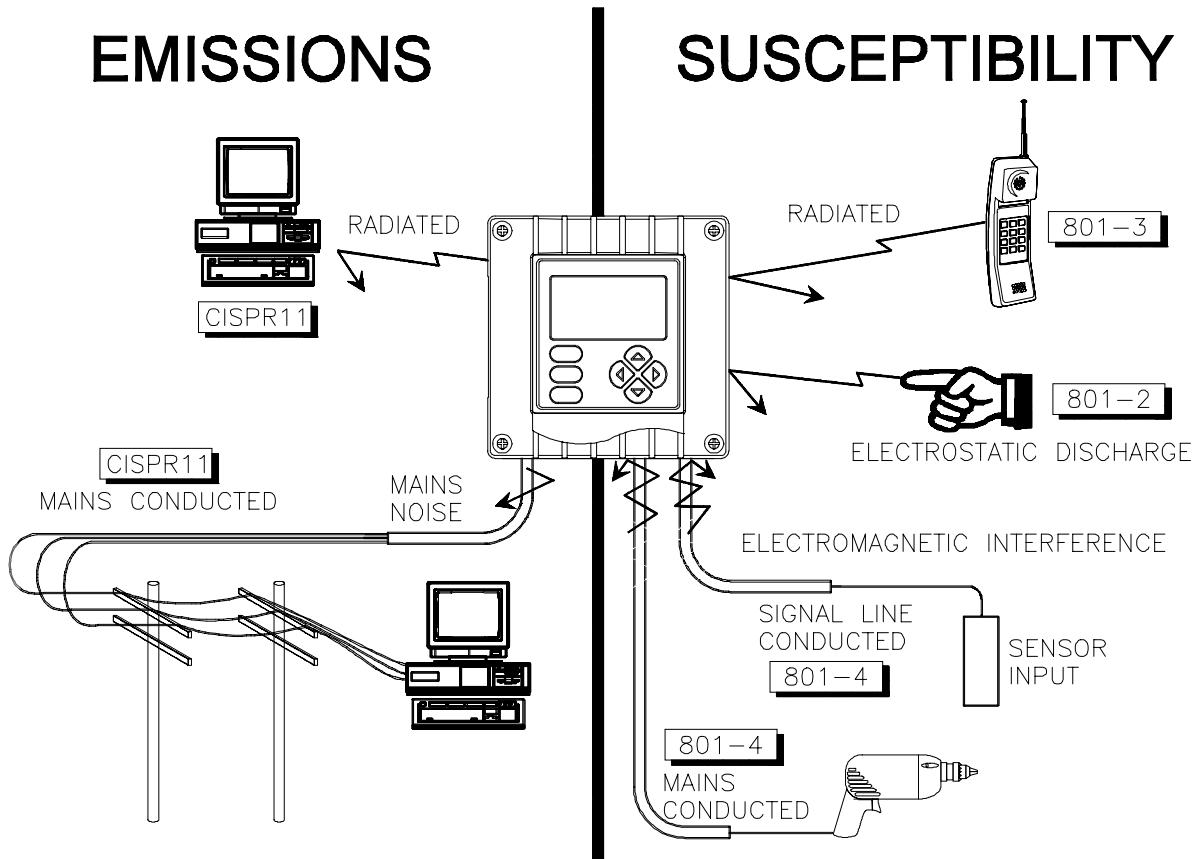

FIGURE 1-1 EMI/RFI Immunity Diagram

SECTION 2

SPECIFICATIONS

2.1 Model 5920Z0 Ozone Sensor

Wetted Materials:
 Protection Cap Assembly Tefzel washers, stainless steel grill, Dacron mesh, and silicone washer
 Membrane Assembly..... 316 stainless steel membrane holding ring, Saran mask, PFA Teflon membrane, and PEEK sensor head

Flow Rate..... 300 to 400 milliliters/minute
 Maximum Pressure 290 psig at 122°F (20 bar at 50°C)
 Sample Temperature Range..... 32-122°F (0-50°C)
 Accuracy..... ± 1% of reading
 Signal Drift..... Less than 1% of reading
 Sensor Cable (integral)..... 5 conductor (plus shield), 10 ft. (3 m) long

2.2 Model O53 Analyzer

Operation

Display..... Graphic dot matrix LCD, 128 x 64 pixels with LED backlighting; 1/2 inch (13 mm) main character height; 1/8 inch (3 mm) auxiliary information character height; menu screens contain up to six text lines

<u>Measurement</u>	<u>Ranges</u>
Ozone Concentration.....	0-50.00 ppm
Temperature	32.0-122.0°F or 0.0-50.0°C
mA Outputs (1 and 2).....	0.00-20.00 mA or 4.00-20.00 mA

Ambient Conditions:
 Operation..... -4 to +140°F (-20 to +60°C); 0-95% relative humidity, non-condensing
 Storage..... -22 to +158°F (-30 to +70°C); 0-95% relative humidity, non-condensing

Relays: Types/OutputsUp to four electromechanical relays; SPDT (Form C) contacts; U.L. rated 5A 115/230 VAC, 5A @ 30 VDC resistive

Operational Mode Each relay (A, B, C, and D) can be assigned to be driven by the measured ozone or temperature

Function Modes:
 Control Settings for high/low phasing, setpoint, deadband, overfeed timer, off delay, and on delay
 AlarmSettings for low alarm point, low alarm point deadband, high alarm point, high alarm point deadband, off delay, and on delay
 Status.....Not configurable; relay only activates when a sensor or analyzer diagnostic WARNING condition exists
 Timer.....Relay is activated by user-entered interval and time duration values
 IndicatorsRelay A, B, C, and D annunciators indicate respective relay status

Temperature Compensation Automatic from 32.0 to 122.0°F (0.0-50.0°C), or manually fixed at a user-entered temperature

Sensor-to-Analyzer Distance 1000 ft. (305 m) maximum

Power Requirements 90-130 VAC, 50/60 Hz. (10 VA max.) or 180-260 VAC, 50/60 Hz. (10 VA max.)

	Sample Calibration.....	With the sensor in the process or a sample, enter the known ozone value determined by laboratory analysis or a comparison reading.
	Analog Outputs	Two isolated 0/4-20 mA outputs; each with 0.004 mA (12-bit) resolution and capability to drive up to 600 ohm loads
		NOTE: Each output can be assigned to represent the measured ozone or temperature. Parameter values can be entered to define the endpoints at which the minimum and maximum mA output values are desired. During calibration, both outputs can be selected to hold their present values, transfer to preset values to operate control elements by an amount corresponding to those values, or remain active to respond to the measured value.
	Communication: RS-232	Enables configuration and retrieval of measured data for one analyzer using IBM-compatible PC and optional software tool kit
	HART.....	Enables configuration and retrieval of measured data for multiple analyzers over a communication link using appropriate hand-held terminal or data system with HART software
	Memory Backup (non-volatile)	All user settings are retained indefinitely in memory (EEPROM)
	EMI/RFI Conformance.....	Exceeds US and meets European standards for conducted and radiated emissions and immunity; certified CE compliant for applications as specified by EN 50081-1 for emissions and EN 50082-2 for immunity
	Electrical Certifications:	
	General Purpose (pending)	UL, C-UL, FM, and CENELEC
	Division 2 (pending)	UL, C-UL, and FM: Groups A, B, C, D, F, and G
	Zone 2 (pending)	CENELEC: Group IIC
Analyzer Performance (Electrical, Analog Outputs)	Accuracy.....	± 2 ppb equal to or below 10 ppb; ± 0.1% of span above 10 ppb
	Sensitivity	± 0.05% of span
	Repeatability	± 0.05% of span
	Temperature Drift	Zero and Span: ± 0.02% of span per °C
	Response Time	1-60 seconds to 90% of value upon step change
Mechanical	Enclosure.....	NEMA 4X; polycarbonate face panel, epoxy-coated cast aluminum door and case with four 1/2 inch (13 mm) conduit holes; nylon mtg. bracket, and stainless steel hardware
	Mounting Configurations.....	Panel, surface, and pipe (horizontal and vertical) mounting
	Net Weight.....	3.5 lbs. (1.6 kg) approximately

PART TWO - INSTALLATION

SECTION 1

UNPACKING

After unpacking, it is recommended to save the shipping carton and packing materials in case the instrument must be stored or re-shipped. Inspect the equipment and packing materials for signs of shipping damage. If there is any evidence of damage, notify the transit carrier immediately.

SECTION 2

MECHANICAL REQUIREMENTS

2.1 Sensor/Analyzer Location

1. It is recommended to locate the analyzer as close as possible to the installed sensor. The maximum allowable distance between an installed sensor and the analyzer is 1000 feet (305 m).
2. Mount the analyzer in a location that is:
 - Clean and dry where there is little or no vibration.
 - Protected from corrosive fluids.
 - Within ambient temperature limits (-4 to +140°F or -20 to +60°C).

CAUTION:

EXPOSING THE ANALYZER TO DIRECT SUNLIGHT MAY INCREASE THE OPERATING TEMPERATURE ABOVE ITS SPECIFIED LIMIT, AND DECREASE DISPLAY VISIBILITY. RECOMMENDATION: IN SEVERE CASES, USE A GLI SUN SHIELD (P/N 1000G3088-001).

2.2 Sensor Preparation for First Use

The Model 5920Z0 ozone sensor, illustrated in Figure 2-1, has a shipping/storage cap, a screw-on protection cap covering the membrane, and an integral sensor cable terminated with stripped/tinned wires.

An optional GLI Model 5920-2 recharge kit is available to recondition and maintain the ozone sensor. The kit includes membranes, mask, electrolyte, polishing powder, membrane holding ring, and special sensor tools.

Shipping conditions can adversely affect the sensor. Therefore, it is important to examine the sensor head before installing the sensor:

1. Remove the shipping/storage cap from the sensor.
2. To examine the sensor head, carefully remove the screw-on protection cap from the sensor using the wrench supplied in the optional GLI Model 5920-2 recharge kit.



NOTE: Take care not to disturb the sensor components in the protection cap, or the membrane covering the sensor head held in place by the membrane holding ring. These components are shown in Figure 4-2 (PART FOUR, Section 3.3), and Figure 5-1 (PART FIVE).

3. Check the sensor head to make sure that:
 - Membrane holding ring is firmly in place
 - Membrane surface is smooth and wrinkle-free
 - Electrolyte beneath the membrane has no bubbles
 - Electrodes appear clear, clean, and bright

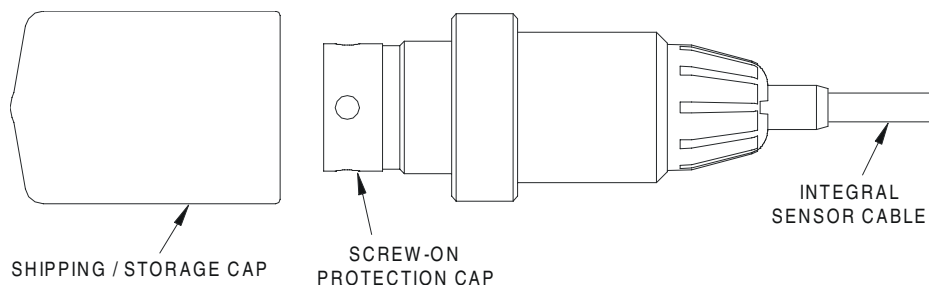

FIGURE 2-1
Basic Sensor Components

2.3 Sensor Mounting

To union mount the Model 5920Z0 ozone sensor using GLI hardware (available in 316 stainless steel or PVC):

1. Refer to Figure 2-2 and install the special GLI union tee in the process (or sample bypass) line. Remove the lock ring from the tee.



NOTE: Make sure that the adapter is fully inserted into the tee.

2. With the shipping/storage cap removed from the front of the sensor, carefully insert the sensor into the adapter in the union tee.
3. Fasten the lock ring onto the union tee to secure the sensor.

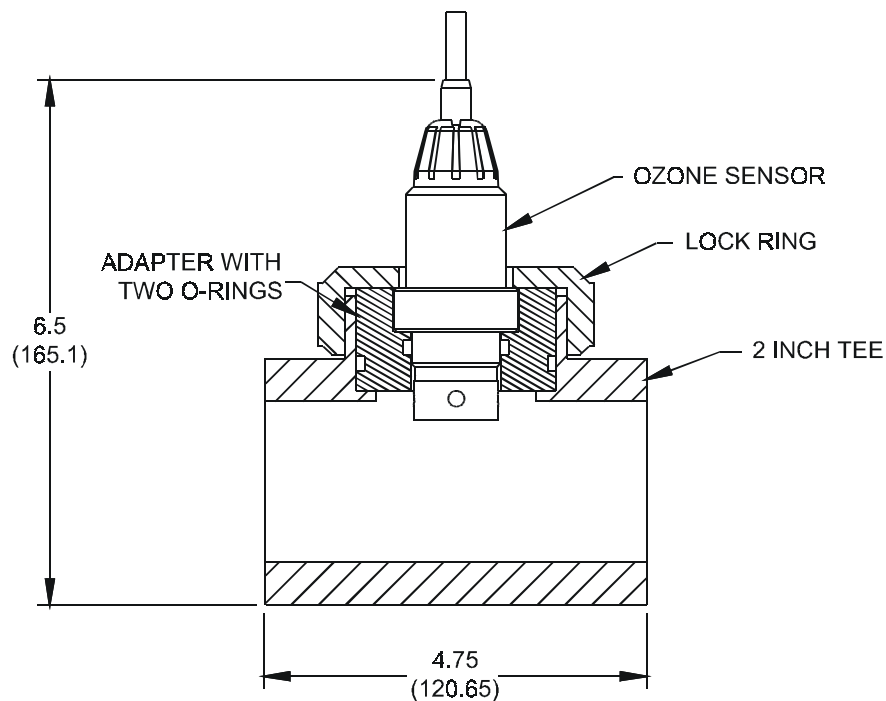

FIGURE 2-2
Union Mount Sensor Installation Dimension Details

2.4 Analyzer Mounting

Figure 2-3 illustrates various ways to mount the analyzer using the supplied bracket and hardware. Determine the mounting method and attach the hardware as shown in the respective illustration. Refer to Figure 2-4 for analyzer installation dimension details.

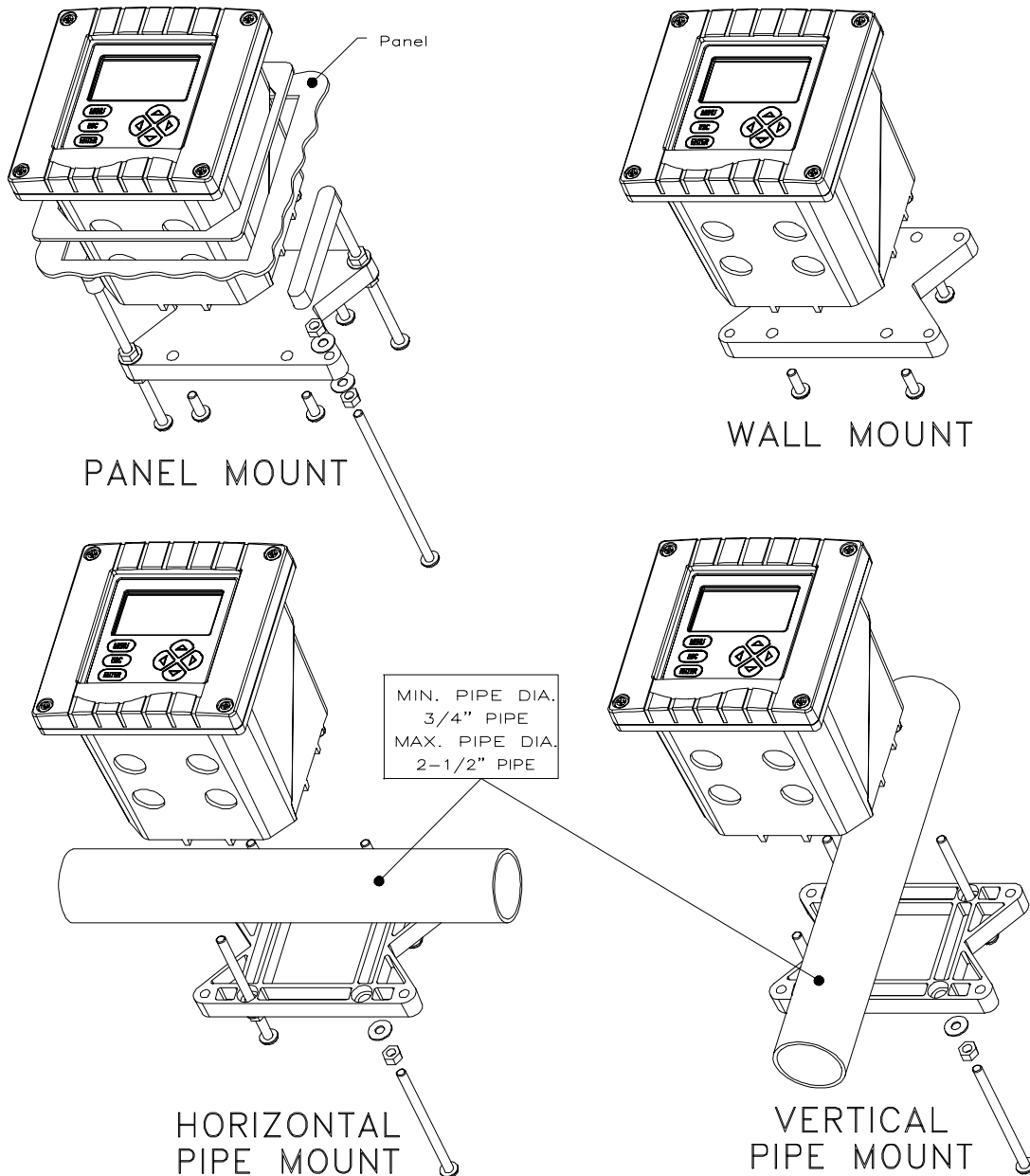

FIGURE 2-3
Analyzer Mounting Arrangements

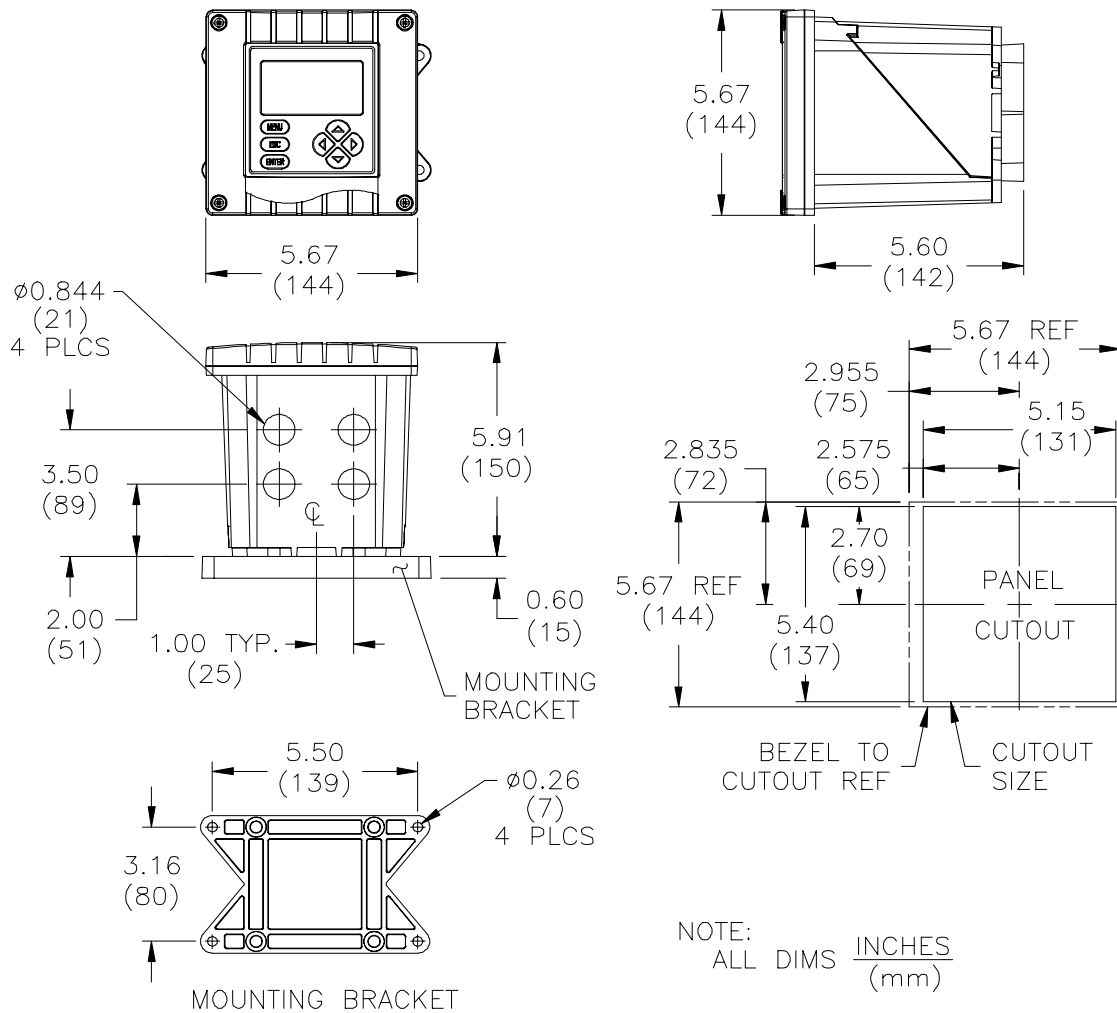

FIGURE 2-4
Analyzer Installation Dimensions Details

2.5 Conduit Hole Requirements

Recommendation: Run all wiring to the analyzer in 1/2-inch, grounded metal conduits. If using only shielded cables, appropriate strain reliefs or cable grips are required. (GLI offers accessory cable grips, part number 3H1091, and watertight locknuts, part number 3H1230, for cable entries.) Seal unused cable entry holes with appropriate plugs.



NOTE: Use NEMA 4-rated fittings and plugs to maintain the watertight integrity of the NEMA 4X enclosure.

SECTION 3

ELECTRICAL CONNECTIONS

To access terminals for electrical connections, open the left-hinged enclosure door by unscrewing the four fasteners. Figure 2-5 shows the terminal arrangement and their designations.



NOTE: All terminals are suitable for single wires up to 14 AWG (2.5 mm²).



Wiring Tip! To comply with European Community (CE) electromagnetic compatibility requirements, follow these general wiring guidelines:

1. Keep all cable shields as short as possible inside the analyzer, and connect them to the ground terminals provided. Performance may be improved by using cable glands that enable the shield to directly contact the analyzer chassis.
2. Use Steward ferrite 28 B0590-000 or equivalent on the sensor cable -- two turns required.
3. In harsh conducted RF conditions, connect the earth ground of the analyzer to a local, known earth ground source.



NOTE: For ease of wiring, connect line power and relay outputs through the back conduit holes before connecting the sensor, and analog outputs.

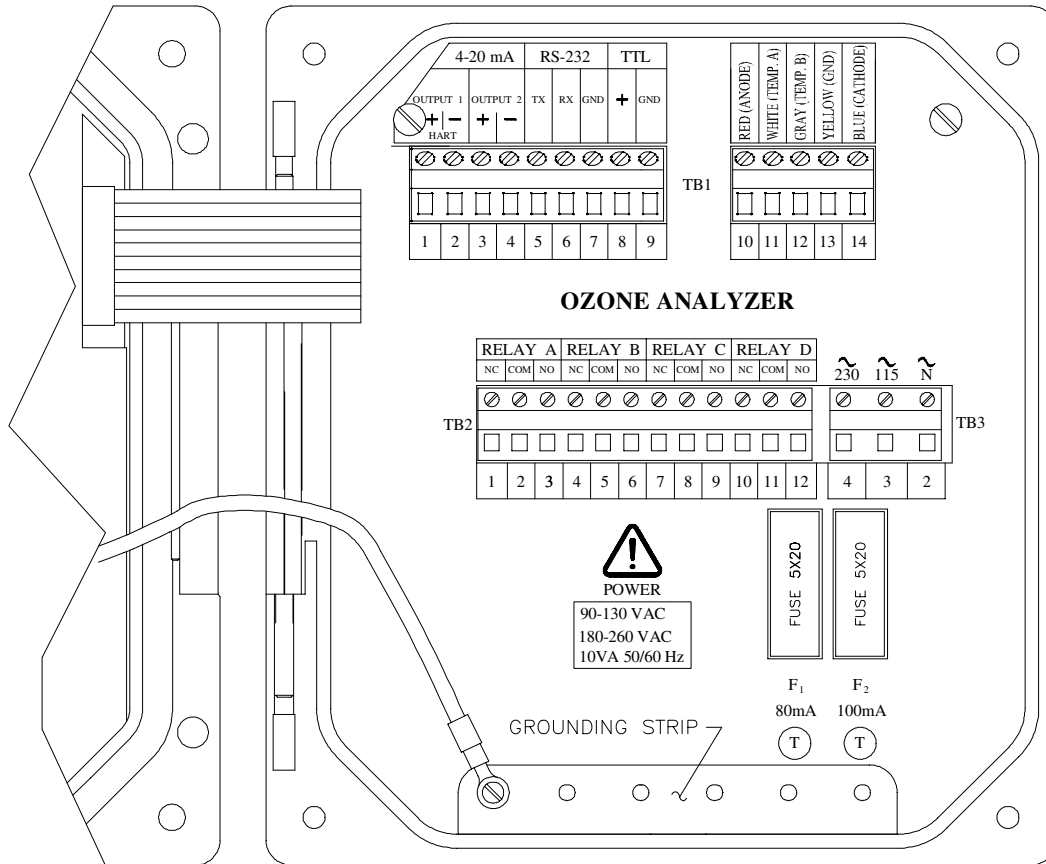

FIGURE 2-5
Analyzer Terminal Designations

3.1 Ozone Sensor



The GLI Model 5920Z0 ozone sensor has a built-in NTC 100K ohm temperature element for automatic temperature compensation and for measuring process temperature.

Wiring Tip! Route the sensor cable in 1/2-inch, grounded metal conduit to protect it from moisture, electrical noise, and mechanical damage.

For installations where the distance between sensor and analyzer exceeds the sensor cable length, indirectly connect the sensor to the analyzer using a junction box and interconnect cable.



NOTE: Do not route the sensor cable (and interconnect cable, if used) in any conduit containing AC power wiring (“electrical noise” may interfere with the sensor signal).

Refer to Figure 2-6 and connect the sensor (or interconnect) cable wires to SENSOR Terminals 10 through 14 on TB1, matching colors as indicated.

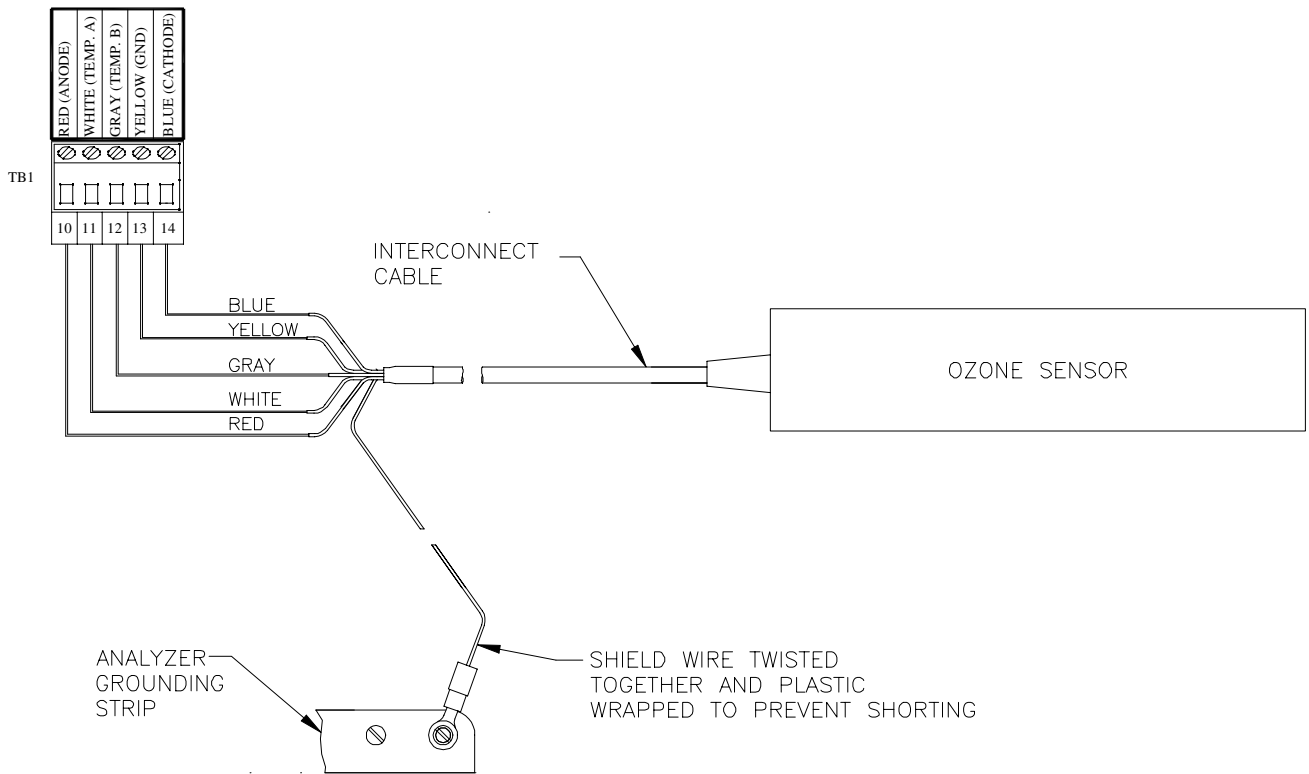

FIGURE 2-6
Connecting Ozone Sensor

3.2 Analog Outputs

Two analog outputs (1 and 2) are provided. Each output can be set to be 0-20 mA or 4-20 mA, and assigned to represent the measured ozone or temperature. **The outputs are isolated from the inputs and earth ground, but not from each other.**

For details on configuring the outputs, refer to PART THREE, Section 4.4.



Wiring Tip! Use high quality, shielded instrumentation cable for connecting the analog outputs. To protect the output signal from EMI/RFI, connect cable shields to one of the 5 open holes on the grounding strip at the bottom of the case (Figure 2-5).

Each 0/4-20 mA output can drive a load of up to 600 ohms.

- **Output 1:** Connect the load to Terminals 1 and 2 on TB1, matching polarity as indicated.
- **Output 2:** Connect the load to Terminals 3 and 4 on TB1, matching polarity as indicated.



NOTE: When using the HART communication option, a digital signal is encoded onto the 4-20 mA analog Output 1 signal. In a HART point-to-point wiring configuration, Output 1 remains available for normal use. However, in a HART multi-drop wiring configuration, Output 1 becomes dedicated to that function and cannot be used. See PART THREE, Section 8 for more HART communication information.

3.3 Relay Outputs

The analyzer may be equipped with up to four electromechanical relays. For relay setup details, see PART THREE, Section 4.5.

CAUTION:

DO NOT EXCEED THE CONTACT RATING FOR EACH RELAY (5A 115/230 VAC). WHEN SWITCHING LARGER CURRENTS, USE AN AUXILIARY RELAY SWITCHED BY THE ANALYZER RELAY TO EXTEND ANALYZER RELAY LIFE. WHEN USING RELAY OUTPUTS, MAKE SURE THAT LINE POWER WIRING CAN ADEQUATELY CONDUCT THE CURRENT DRAW OF THE SWITCHED LOAD(S).

Up to four sets of SPDT relay outputs (Relays A, B, C, and D) are provided at Terminals 1 through 12 on TB2. **The relay outputs are not powered.** The line power used to power the analyzer may also be used to power control/ alarm devices with these relay contacts. See Figure 2-7 for a general wiring arrangement. Always check control wiring to insure that line power will not be shorted by the relay switching action, and that wiring conforms to local codes.

WARNING:

MAKE SURE LINE POWER IS NOT PRESENT WHILE CONNECTING WIRES TO TB2 RELAY TERMINALS.

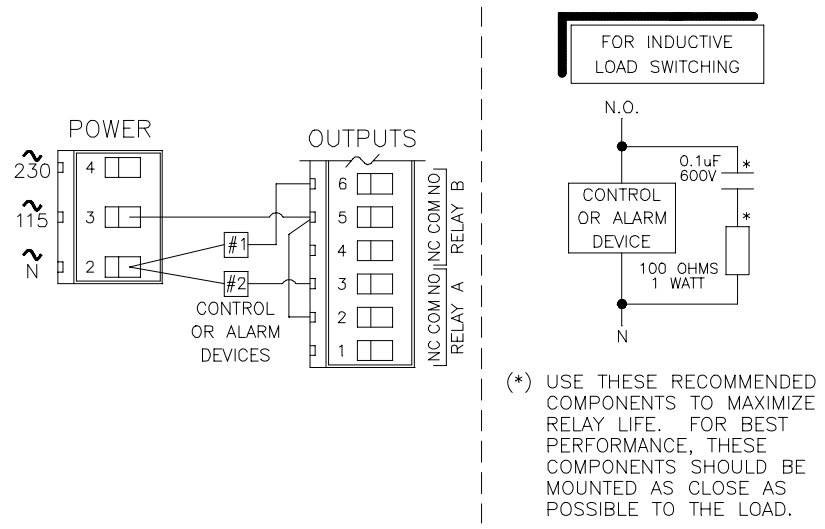

FIGURE 2-7
Connecting Control/Alarm Device(s) To Electromechanical Relay(s)

3.4 Closed Contact TTL Input

The closed contact input feature of the analyzer enables you to conveniently:

- Hold analog outputs at their last measured values.
- Hold CONTROL and ALARM relays in their present on/off states.
- Suspend countdown, temporarily, of active TIMER relays.

To initiate these actions, momentarily connect TTL Terminals 8 and 9 on TB1, either locally or remotely.



NOTE: *During calibration, the selected output state (“HOLD,” “XFER” or “ACTIVE”) overrides the actions of the TTL input feature.*

3.5 Line Power

Refer to Figures 2-8, 2-9 or 2-10 on the next page and connect line power to TB3 terminals using the standard three-wire connection arrangement. **Use wiring practices which conform to local codes** (example: National Electric Code Handbook in the U.S.A.).

WARNING:

REMOVE LINE POWER WHILE CONNECTING LINE POWER WIRES TO THE TB3 TERMINALS. ALSO, USE ONLY THE STANDARD THREE-WIRE CONNECTION ARRANGEMENT FOR SINGLE-PHASE LINE POWER TO PREVENT AN UNSAFE CONDITION, AND TO ENSURE PROPER ANALYZER OPERATION.



NOTE: *In all cases, connect the line power cable ground wire (usually green) to one of the 5 open holes on the grounding strip at the bottom of the analyzer case (Figure 2-5).*

The “115” and “230” voltage circuits are protected with internal, board-mounted slow-blow fuses.



NOTE: *For 230 volt split phase line power, be sure to conform to local codes with regard to fusing the 115 volt line connected to the “N” terminal.*

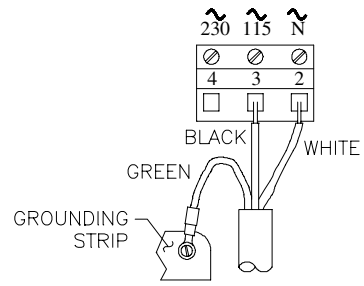

FIGURE 2-8
Connecting 115 Volt Single Phase Line Power (90-130 VAC)

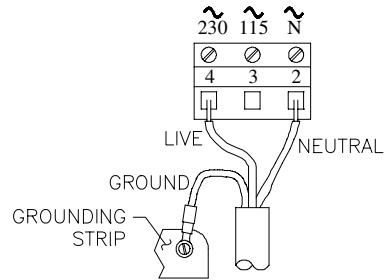

FIGURE 2-9
Connecting 230 Volt Single Phase Line Power (180-260 VAC)

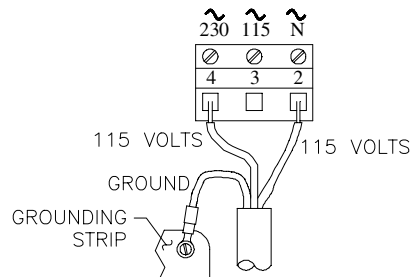

FIGURE 2-10
Connecting 230 Volt Split Phase Line Power (180-260 VAC)

PART THREE - OPERATION

SECTION 1

USER INTERFACE

1.1 Display

The user interface consists of an LCD display and a keypad with **MENU**, **ENTER**, **ESC**, \leftarrow , \rightarrow , \uparrow , and \downarrow keys.

By using the keypad, you can display three types of screens:

- **MEASURE Screen:** The normal display mode which shows measured values. The measured ozone is always shown on the display's main middle line. Pressing the \downarrow or \uparrow key changes the display's bottom auxiliary line (in reverse video) to show these other measurements:
 - Measured temperature (°C or °F).
 - Analog Output 1 value (mA).
 - Analog Output 2 value (mA).

An example of a typical MEASURE screen is:

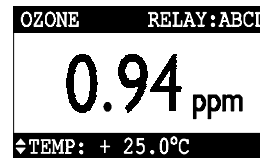

On the MEASURE screen's top line, Relay A, B, C, and D annunciators will appear when their relay operational state changes. When a relay overfeed timer is used and it has "timed out," the respective relay annunciator continuously blinks until the overfeed condition is resolved.

- **Menu Screens:** These top-level and lower-level (sub-menu) screens within the three main branches of the menu tree are used to access edit/selection screens for configuration. (EXIT screens at the end of each menu branch enable you to move up one level in the menu tree by pressing the **ENTER** key. This is functionally the same as pressing the **ESC** key.)
- **Edit/Selection Screens:** These screens enter values/choices to calibrate, configure, and test the analyzer.

1.2 Keypad

The keypad enables you to move throughout the analyzer menu tree. The keys and their related functions are:

1. **MENU key:** Pressing this key always displays the top of the menu tree ("MAIN MENU" selection screen). To

display the top-level menu screen for a desired main branch (CALIBRATE, CONFIGURE or TEST/MAINT), use the ↓ **and** ↑ **keys** to select the corresponding line, and press the **ENTER** key. (Pressing the **MENU** key also “aborts” the procedure to change values or selections.)

2. **ENTER** key: Pressing this key does two things: it displays submenu and edit/selection screens, and it enters (saves) configuration values/selections.
3. **ESC** key: Pressing this key always takes the display up one level in the menu tree. (Example: With the “MAIN MENU” branch selection screen displayed, pressing the **ESC** key once takes the display up one level to the MEASURE screen.) This key can also “abort” the procedure to change a value or selection.
4. ⇐ **and** ⇒ **keys**: Depending on the type of displayed screen, these keys do the following:
 - MEASURE/Menu Screens: These keys are non-functional.
 - Edit/Selection Screens: “Coarse” adjusts the displayed numerical value/choice.
5. ↑ **and** ↓ **keys**: Depending on the type of displayed screen, these keys do the following:
 - MEASURE Screen: Changes the bottom auxiliary display line, shown in reverse video, between measured temperature, and Output 1 or Output 2 mA value.
 - Menu Screens: Moves reverse video cursor up or down respectively to select a displayed line item.
 - Edit/Selection Screens: “Fine” adjusts numerical value, enclosed by parenthesis, up or down respectively or moves up or down respectively between choices enclosed by parenthesis.

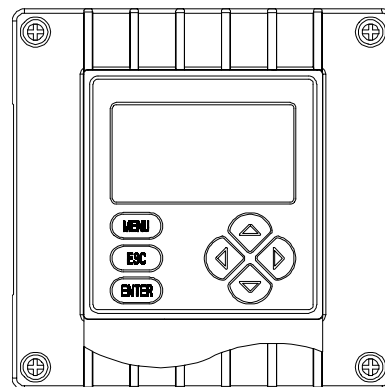

FIGURE 3-1 Analyzer Keypad

1.3 MEASURE Screen (normal display mode)

The MEASURE screen is normally displayed. Pressing the **MENU key** temporarily replaces the MEASURE screen with the “MAIN MENU” branch selection screen. Using the keypad, you can then display other screens to calibrate, configure or test the analyzer. **If the keypad is not used within 30 minutes, except during calibration and while using specific analyzer test/maintenance functions, the display will automatically return to the MEASURE screen.** To display the MEASURE screen at any time, press the **MENU key** once and then the **ESC key** once.

Pressing the ↓ or ↑ **key** with the MEASURE screen displayed scrolls between other measurements on the bottom auxiliary display line. These MEASURE screen examples illustrate this feature:

OZONE	RELAY:ABCD
0.94 ppm	
↕TEMP: + 25.0°C	

OZONE	RELAY:ABCD
0.94 ppm	
↕OUTPUT 1: 7.24mA	

OZONE	RELAY:ABCD
0.94 ppm	
↕OUTPUT 2: 14.03mA	



NOTE: *When the analyzer returns to its normal MEASURE screen mode, the appearing readout is always the version last selected. Note that these MEASURE screen examples show the “OZONE” default notation on their top lines, illustrating the analyzer notation feature. To create your own notation, refer to PART THREE, Section 4.2, subheading “ENTER NOTE (top line of MEASURE screen).”*

When a measured value is beyond the analyzer measuring range, a series of “+” or “-” screen symbols appear, respectively indicating that the value is above or below range. This also includes the temperature range.

SECTION 2

MENU STRUCTURE

The analyzer menu tree is divided into three main branches: CALIBRATE, CONFIGURE, and TEST/MAINT. Each main branch is structured similarly in layers with top-level menu screens, related lower-level submenu screens and, in many cases, sub-submenu screens.

Each layer contains an EXIT line or screen to return the display up one level to the previous layer of screens.



Menu Structure Tip! For operating convenience, the layers within each main branch are organized with the most frequently used function screens at their beginning, rather than the functions used for initial startup.

2.1 Displaying Main Branch Selection Screen

Press the **MENU** key to always display this main branch selection screen:

```

MAIN MENU
▶CALIBRATE
▶CONFIGURE
▶TEST/MAINT
◀EXIT
  
```

2.2 Displaying Top-level Menu Screens

1. After displaying the main branch selection screen, use the ↓ and ↑ keys to select the line corresponding to the desired branch (shown in reverse video).
2. Press the **ENTER** key to display the top-level menu screen for that branch.

The top-level menu screens for each main branch are:

```

CALIBRATE
▶SENSOR
▶TEMPERATURE
▶CAL OUTPUTS
◀EXIT
  
```

```

CONFIGURE
▶SET OUTPUT 1
▶SET OUTPUT 2
▶SET RELAY A
▶SET RELAY B
▶SET RELAY C
▶SET RELAY D
▶SET PASSCODE
▶SET °C OR °F
▶LANGUAGE
▶SENSOR
◀EXIT
  
```

```

TEST/MAINT
▶STATUS
▶SENSOR AIR TEST
▶HOLD OUTPUTS
▶OVERFEED RESET
▶OUTPUT 1
▶OUTPUT 2
▶RELAY A
▶RELAY B
▶RELAY C
▶RELAY D
▶EPROM VERSION
▶SELECT SIM
▶SIM SENSOR
▶RESET CONFIGURE
▶RESET CALIBRATE
◀EXIT
  
```



Menu Structure Tip! The ▶ symbol pointing at each listed item indicates there is a related lower-level submenu screen, sub-submenu screen, or edit/selection screen.

Some menu lists are too long to completely fit on the screen. A ↓ symbol at the bottom right of the list

indicates that you can display hidden items by pressing the **↓ key**. As you display these items a **↑** symbol appears, indicating that items now hidden above and below the list can be displayed by respectively pressing the **↑ or ↓ key**. When a **↑** symbol appears, it indicates you have reached the end of the menu list. You can move back up the list using the **↑ key**.

2.3 Displaying Submenu Screens

1. After displaying the top-level menu screen, use the **↓ and ↑ keys** to select the line corresponding to the desired lower-level submenu screen.
2. Press the **ENTER key** to display the submenu screen.

When a submenu or sub-submenu screen contains a first line ending with a “?”, it is an edit/selection screen. Pressing the **↓ or ↑ key** changes the value/choice enclosed by parenthesis (second line on screen).

Example: With this submenu edit screen displayed:

```
SET °C OR °F?
( °C      )
```

pressing the **↓ key** displays this related choice:

```
SET °C OR °F?
( °F      )
```

2.4 Adjusting Edit/Selection Screen Values

Use **the arrow keys** to edit/change the value/choice enclosed by parenthesis (examples shown above and below).

```
SET PARAMETER?
( SENSOR      )
```

```
SET 4mA VALUE?
( 0.00 ppm    )
```

A choice can be changed by simply using the **↑ and ↓ keys**. Numerical values can be “coarse” adjusted using **⇐ and ⇒ keys**, and “fine” adjusted using **↑ and ↓ keys**. The longer the key is pressed, the faster the number changes.

2.5 Entering (Storing) Edit/Selection Screen Values/Choices



With the desired value/choice displayed, press the **ENTER key** to enter (store) it into the non-volatile analyzer memory. The previous screen will then re-appear.

NOTE: You can always press the **ESC key** to abort saving a new setting. The original setting will be retained.

SECTION 3

ADJUSTING DISPLAY CONTRAST

Ambient lighting conditions may make it necessary to adjust the analyzer display contrast to improve visibility. With the MEASURE screen displayed, press **and hold** the **ENTER** key and **simultaneously** press the **↑** or **↓** key until attaining the desired contrast.

SECTION 4

ANALYZER CONFIGURATION



NOTE: When the passcode feature is enabled (Section 4.6), you must successfully enter the passcode before attempting to enter a configuration setting.

4.1 Selecting LANGUAGE to Operate Analyzer

The analyzer is equipped to display operating screens in various languages including English, French (Français), German (Deutsche), Spanish (Español), and others. The analyzer is factory-set for English. To change languages:

```

MAIN MENU
▶CALIBRATE
▶CONFIGURE
▶TEST/MAINT
◀EXIT
  
```

1. Press **MENU** key to display . Use **↓** key to select the "CONFIGURE" line.

```

CONFIGURE
▶SET OUTPUT 1
▶SET OUTPUT 2
▶SET RELAY A
▶SET RELAY B
▶SET RELAY C
▶SET RELAY D
▶SET PASSCODE
▶SET °C OR °F
▶LANGUAGE
▶SENSOR
◀EXIT
  
```

2. Press **ENTER** key to display . Use **↓** key to select the "LANGUAGE" line.

```

LANGUAGE?
(ENGLISH )
  
```

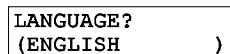
3. Press **ENTER** key to display . Use **↓** and **↑** keys to view the language choices. With the desired language displayed, press **ENTER** key to enter this selection.



NOTE: After a language is selected and entered, all screens will be displayed in that language.

4.2 Configuring Sensor Characteristics

Select
DISPLAY FORMAT

The analyzer must be configured to define the characteristics of the sensor including its display format, input signal filtering, pulse suppression, screen notation, and temperature element type.

Select the desired MEASURE screen display format for measured ozone. The selected resolution will also appear on all applicable edit/selection menu screens.

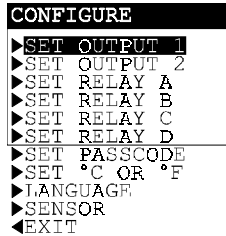

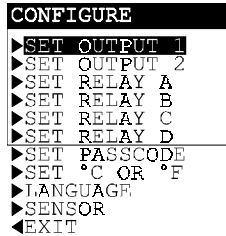
1. With the  screen displayed, use **↓ key** to select “SENSOR” line.

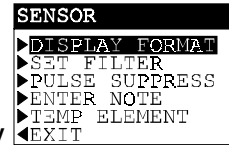

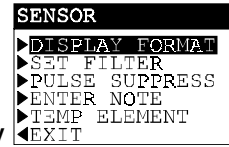
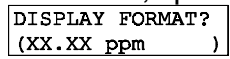
2. Press **ENTER key** to display .
3. With the “DISPLAY FORMAT” line selected, press **ENTER key** to display a screen like . Use **↓ and ↑ keys** to view both choices (XX.XX ppm or X.XXX ppm). With the desired choice displayed, press **ENTER key** to enter this selection.



NOTE: The third digit to the right of the decimal point in the X.XXX format is only operational down to 0.010 ppm.

SET FILTER Time

A time constant (in seconds) can be set to filter or “smooth out” the sensor signal. A minimum value of “0 seconds” has no smoothing effect. A maximum value of “60 seconds” provides maximum smoothing. Deciding what sensor signal filter time to use is a compromise. The higher the filter time, the longer the sensor signal response time will be to a change in the actual process value.

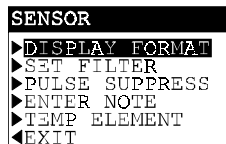

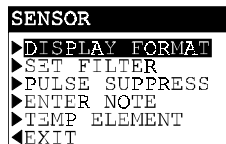
1. With the  screen displayed, use **↓ key** to select the “SET FILTER” line.

Select
PULSE SUPPRESS
(on or off)

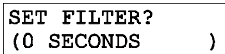
2. Press **ENTER** key to display a screen like . Use **arrow keys** to adjust the displayed value to the desired filter time, and press **ENTER** key to enter this value.

Sometimes an external interference may occasionally cause the measurement system to provide unstable readings. Common causes include entrained gas bubbles in the process, and electromagnetic interference (EMI or “electrical noise” pulses). The analyzer has a pulse suppression feature to counteract this condition and stabilize readings. Example: Suppose the analyzer reading is steadily showing 2.13 ppm, then suddenly jumps to 3.94 ppm for a few seconds, and returns to 2.13 ppm. By turning on this feature, the analyzer will perceive this as a temporary upset, “suppressing” most of this pulse change and providing a smoother measurement reading.

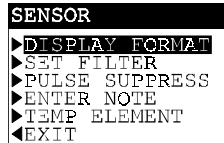

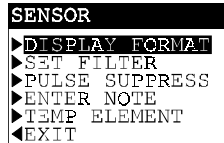
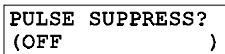
1. With the  screen displayed, use **↓ key** to select the “PULSE SUPPRESS” line.
2. Press **ENTER** key to display a screen like . Use **↓ and ↑ keys** to view both choices (OFF or ON). With the desired choice displayed, press **ENTER** key to enter this selection.

ENTER NOTE (top line
of MEASURE screen)

The top line of the MEASURE screen is factory set to read “OZONE” This notation can be changed, for example, to “BASIN 1” to tailor the analyzer MEASURE screen to the application. The notation is limited to eight characters which can be a combination of capital letters A through Z, numbers 0 through 9, periods, and spaces.

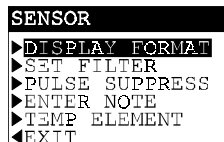

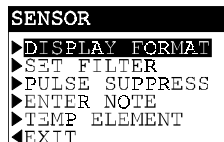
1. With the  screen displayed, use **↓ key** to select the “ENTER NOTE” line.

2. Press **ENTER key** to display

ENTER NOTE? ([O] ZONE)

 . Create the desired notation on the second line:
 - A. Starting with extreme left character position, use **↑ and ↓ keys** to select the desired first character.
 - B. Press **⇒ key once** to select the next position, and use **↑ and ↓ keys** to select its desired character.
 - C. Repeat procedure until desired notation is displayed.
3. Press **ENTER key** to enter the displayed notation.

Select TEMP ELEMENT Type



The temperature element type is factory-set to “NTC 100K” to define the built-in temperature element of the Model 5920Z0 ozone sensor for automatic temperature compensation.

NOTE: When “NTC 100K” temperature element type is selected but the element is not connected to the analyzer, a “WARNING: CHECK STATUS” message will appear. To prevent or clear this message, connect the element or select “MANUAL.”

To configure the analyzer for fixed manual temperature compensation, select “MANUAL” and enter a specific temperature value:

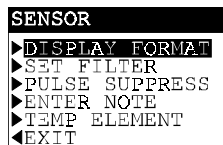

1. With the

SENSOR
▶ DISPLAY FORMAT
▶ SET FILTER
▶ PULSE SUPPRESS
▶ ENTER NOTE
▶ TEMP ELEMENT
◀ EXIT

 screen displayed, use **↓ key** to select the “TEMP ELEMENT” line.

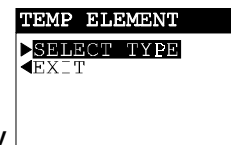

2. Press **ENTER key** to display

SELECT TYPE? (NTC 100K)

 .
3. With the “SELECT TYPE” line selected, press **ENTER key** to display

SELECT TYPE? (NTC 100K)

 . Use **↓ key** to select “MANUAL” which configures the analyzer for fixed manual temperature compensation.

- 4. Press **ENTER key** to enter this selection. Now you must set the specific manual temperature compensation value:

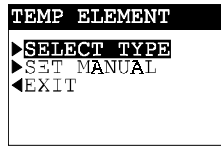

- A. With the screen displayed, use **↓ key** to select the “SET MANUAL” line.
- B. Press **ENTER key** to display a screen like . Use **arrow keys** to adjust the displayed value to the desired fixed temperature, and press **ENTER key** to enter it.

4.3 SET °C OR °F (temperature display)

The MEASURE screen can be set to display temperature values in °C or °F. In either case, the temperature display format is always “XX.X.”

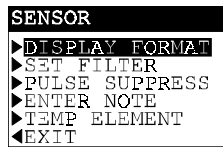

- 1. With the screen displayed, press **ESC**

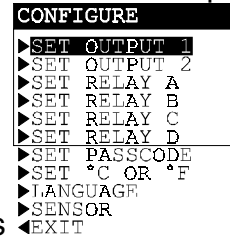

key once to display this top-level screen.

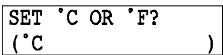
- 2. Use **↓ key** to select the “SET °C OR °F” line.
- 3. Press **ENTER key** to display a screen like . Use **↓ and ↑ keys** to view both choices (°C or °F). With the desired choice displayed, press **ENTER key** to enter this selection.

4.4 Configuring Analog Outputs (1 and 2)

The analyzer provides two isolated analog outputs (1 and 2). During calibration, the analog outputs can be held, transferred to a user-preset value, or remain active. During normal measurement operation, the analog outputs can be held at their last measured values:

- For up to 30 minutes by selecting the “HOLD OUTPUTS” function in the TEST/MAINT menu and pressing the **ENTER** key.
- For an indefinite period by locally or remotely connecting the TTL input Terminals 8 and 9 on TB1.
- During the user-set DURATION and OFF DELAY time periods for an activated TIMER relay.

If a TEST/MAINT hold is applied in addition to a TTL hold, both “holds” must be removed before the analog outputs return to active status. If the outputs are set to XFER or ACTIVE during calibration, they remain in that state regardless of the connection status at the TTL input terminals or TIMER relay status.

From the moment output hold is initiated during calibration or by the “HOLD OUTPUTS” function in the TEST/MAINT menu or TTL input feature, the TIMER relay INTERVAL or DURATION elapsed time countdowns are temporarily suspended. Also, TIMER relays counting down DURATION time are turned off. When output hold ends, TIMER relays resume their INTERVAL or DURATION countdowns from the suspended time. When a TIMER relay is counting down DURATION time, both outputs are temporarily re-held until after the preset DURATION time and OFF DELAY time (if used) elapses.



NOTE: *When using the HART communication option, a digital signal is encoded onto the 4-20 mA analog Output 1 signal. In a HART SINGLE MODE wiring configuration, Output 1 remains available for normal use. However, in a HART MULTI-DROP wiring configuration, Output 1 becomes dedicated to that function and cannot be used. See PART THREE, Section 8 for more HART communication information.*

These instructions configure Output 1. Configure Output 2 in the same way using its respective menu screens.

SET PARAMETER
(representation)

Each output can be assigned to represent the SENSOR (measured ozone) or measured TEMPERATURE.

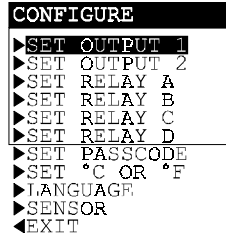

1. With the screen displayed and the "SET OUTPUT 1" line selected, press **ENTER** key to

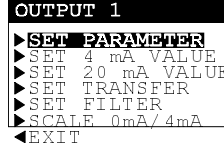

display

2. With the "SET PARAMETER" line selected, press **ENTER** key to display a screen like

SET PARAMETER? (SENSOR)

. Use **↓** and **↑** keys to view the choices. With the desired choice displayed, press **ENTER** key to enter this selection.

SET 0/4 mA and
20 mA VALUES
(range expand)

You can set the ozone (or temperature) values to define the endpoints at which the minimum and maximum output values are desired.

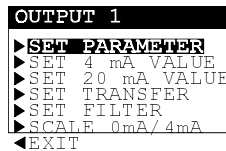

1. With the screen displayed, use **↓** key to select the "SET 4 mA VALUE" line.
2. Press **ENTER** key to display a screen like

SET 4mA VALUE? (XX.XX ppm)

. Use **arrow** keys to set the displayed value at which 0/4 mA is desired, and press **ENTER** key to enter the value.

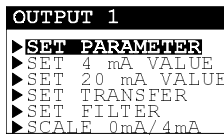

3. After the screen re-appears, use **↓** key to select the "SET 20 mA VALUE" line.

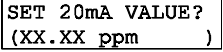
- Press **ENTER** key to display a screen like . Use **arrow keys** to set the displayed value at which 20 mA is desired, and press **ENTER** key to enter the value.





NOTE: If the same values are set for 0/4 mA and 20 mA, the output automatically goes to, and remains at, 20 mA.

SET TRANSFER
Value (mA)

Each analog output is normally active (responds to the measured value of its assigned parameter). However, during calibration, you can transfer (XFER) each output to a preset value to operate a control element by an amount corresponding to that value.

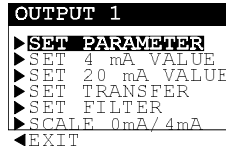
To set a mA transfer value for an analog output to suit your application:

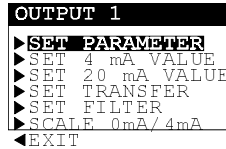

- With the  screen displayed, use **↓ key** to select the “SET TRANSFER” line.
- Press **ENTER** key to display a screen like . Use **arrow keys** to set the displayed value to the desired transfer value, and press **ENTER** key to enter it.

SET FILTER Time

A time constant (in seconds) can be set to filter or “smooth out” the output signal. A minimum value of “0 seconds” has no smoothing effect. A maximum value of “60 seconds” provides maximum smoothing. Deciding what output filter time to use is a compromise. The higher the filter time, the longer the output signal response time will be to a change in the measured value.

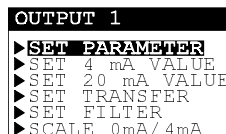

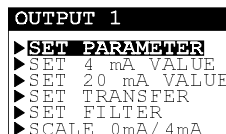
- With the  screen displayed, use **↓ key** to select the “SET FILTER” line.

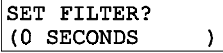
2. Press **ENTER** key to display a screen like . Use **arrow keys** to adjust the displayed value to the desired filter time, and press **ENTER** key to enter it.

Select SCALE 0 mA/ 4 mA (low endpoint)

Each output can be set to be 0-20 mA or 4-20 mA.

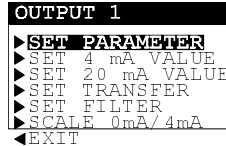

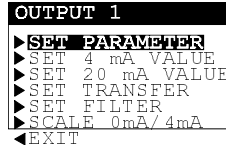
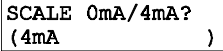
1. With the  screen displayed, use **↓** key to select the “SCALE 0mA/4mA” line.
2. Press **ENTER** key to display a screen like . Use **↓** and **↑** keys to view both choices. With the desired choice displayed, press **ENTER** key to enter this selection.

4.5 Configuring Relays (A, B, C, and D)

The analyzer may be equipped with up to four electromechanical relays (A, B, C, and D). Each relay can be set to function as a CONTROL, ALARM, STATUS or TIMER relay. For details on each relay function, see subsection “SET FUNCTION Mode.”

During calibration, CONTROL and ALARM relays can be held, transferred to preset on/off states or remain active. During normal measurement operation, CONTROL and ALARM relays can be held in their present on/off states:

- For up to 30 minutes by selecting the “HOLD OUTPUTS” line in the TEST/MAINT menu and pressing the **ENTER** key.
- For an indefinite period by locally or remotely connecting the TTL input Terminals 8 and 9 on TB1.

If a TEST/MAINT hold is applied in addition to a TTL hold, both “holds” must be removed before CONTROL and ALARM relays return to their active states. If the relays are set to XFER or ACTIVE during calibration, they remain in that corresponding on/off state regardless of the connection status at the TTL input terminals.



NOTE: *TIMER* relays function much differently than *CONTROL* or *ALARM* relays. See the *TIMER* relay description in the “*SET FUNCTION Mode*” subsection for details.

These instructions configure Relay A. Configure other relays in the same way using their respective menu screens.

SET PARAMETER
(representation)

Each CONTROL or ALARM relay can be assigned to operate using the measured ozone or temperature.



NOTE: *Since TIMER and STATUS function relays are driven by other criteria, the parameter assigned to these relays is not relevant and, therefore, disregarded.*

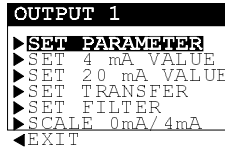

1. With the submenu screen displayed,

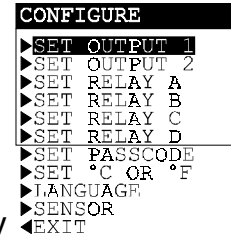

press **ESC** key once to display

2. Use **↓** key to select the “**SET RELAY A**” line, and press

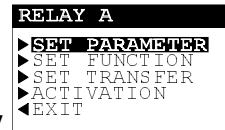

ENTER key to display

3. With the “**SET PARAMETER**” line selected, press

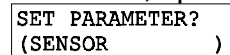

ENTER key to display a screen like **SET PARAMETER? (SENSOR)**. Use **↓** and **↑** keys to view both choices (SENSOR for measured ozone or TEMPERATURE). With the desired choice displayed, press **ENTER** key to enter this selection.

SET FUNCTION Mode
(alarm, control,
status or timer)

Each relay can be selected to function as a:

- **ALARM** relay (with separate high and low alarm points and deadbands) that operates in response to the measured ozone or temperature.
- **CONTROL** relay (with phasing, setpoint, deadband, and overfeed timer) that operates in response to the measure ozone or temperature.
- **STATUS** relay that is not configurable. It is a dedicated system diagnostic-only alarm relay that automatically energizes when the “WARNING CHECK STATUS” message flashes on the MEASURE screen. This occurs when the analyzer detects a sensor or analyzer “fail” diagnostic condition (see PART THREE, Section 6.1 for details).
- **TIMER** relay that is intended to control a sensor cleaning system or other device on a timed basis. A TIMER relay is activated after an entered INTERVAL time of up to 999.9 minutes expires. The TIMER relay remains on for the entered DURATION time (1-999 seconds).



NOTE: *When a TIMER relay is counting down DURATION time, both analog outputs and all ALARM and CONTROL relays are automatically “held” to ensure that connected devices are not disrupted by the sensor cleaning upset condition. An OFF DELAY time (1-999 seconds) can be entered to define how long after the TIMER relay turns off that outputs and relays will remain held, providing time for the sensor to stabilize after cleaning.*

From the moment output hold is initiated during calibration or by the “HOLD OUTPUTS” function in the TEST/MAINT menu or TTL input feature, the TIMER relay INTERVAL or DURATION elapsed time count-downs are temporarily suspended. Also, TIMER relays counting down DURATION time are turned off. When output hold ends, TIMER relays resume their INTERVAL or DURATION countdowns from the suspended time. When a TIMER relay is counting down DURATION time, both outputs are temporarily re-held until after the preset DURATION time and OFF DELAY time (if used) elapses.

To set the relay function:

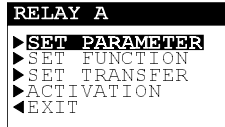

1. With the screen displayed, use **↓ key** to select the “SET FUNCTION” line.
2. Press **ENTER key** to display a screen like

```
SET FUNCTION?
(ALARM )
```

. Use **↓ and ↑ keys** to view the choices (ALARM, CONTROL, STATUS or TIMER). With the desired choice displayed, press **ENTER key** to enter this selection.

SET TRANSFER Mode
(relay on or off)

Normally, each CONTROL and ALARM relay is active, responding to the measured value of its assigned parameter (ozone or temperature). During calibration, however, you can transfer (XFER) each relay to a preset on/off transfer state to suit your application requirements:

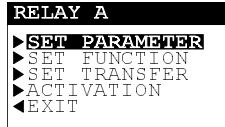

1. With the screen displayed, use **↓ key** to select the “SET TRANSFER” line.
2. Press **ENTER key** to display a screen like

```
SET TRANSFER?
(DE-ENERGIZED )
```

. Use **↓ and ↑ keys** to view both choices (DE-ENERGIZED or ENERGIZED). With the desired choice displayed, press **ENTER key** to enter this selection.

ACTIVATION
(configuration values)

The group of configuration settings available to a relay is dependent on its selected function mode (ALARM, CONTROL or TIMER). **Relays set for STATUS function are not configurable.** Table A describes all relay configuration settings, categorized by relay function mode:

Table A -- RELAY CONFIGURATION SETTINGS	
Setting	Description
For ALARM Relay	
Low Alarm	Sets the value at which the relay will turn on in response to <u>decreasing</u> measured value.
High Alarm	Sets the value at which the relay will turn on in response to <u>increasing</u> measured value.
Low Deadband	Sets the range in which the relay remains on after the measured value <u>increases above</u> the low alarm value.
High Deadband	Sets the range in which the relay remains on after the measured value <u>decreases below</u> the high alarm value.
Off Delay	Sets a time (0-300 seconds) to delay the relay from normally turning <u>off</u> .
On Delay	Sets a time (0-300 seconds) to delay the relay from normally turning <u>on</u> .
For CONTROL Relay	
Phase	A “high” phase assigns the relay setpoint to respond to increasing measured value; conversely, a “low” phase assigns the relay setpoint to respond to decreasing measured value.
Setpoint	Sets the value at which the relay will turn on.
Deadband	Sets the range in which the relay remains on after the measured value decreases below the setpoint value (high phase relay) or increases above the setpoint value (low phase relay).
Overfeed Timer	Sets the time (0-999.9 min.) to limit how long the relay can remain “on.” For more details on overfeed timer operation, see PART THREE, Section 7.
Off Delay	Sets a time (0-300 seconds) to delay the relay from normally turning <u>off</u> .
On Delay	Sets a time (0-300 seconds) to delay the relay from normally turning <u>on</u> .
For TIMER Relay	
Interval	Sets a time (0-999.9 min.) to establish how long the relay remains “off” before it starts a sensor cleaning.
Duration	Sets the time (0-999 seconds) to limit how long the timer relay remains “on” (sensor cleaning duration).
Off Delay	Sets a time (0-999 seconds) to establish how long after the timer relay turns off that the analog outputs and alarm or control relays remain “held.”
For STATUS Relay	
No settings available -- STATUS relay is not configurable.	



NOTE: *It is possible to enter values that always keep a relay active or inactive. To avoid this, be sure that “low” values are lower than “high” values.*

The “off delay” and “on delay” settings, available to CONTROL or ALARM function relays, may be beneficial in eliminating process “overshoot” when there are long process pipe runs or delays in mixing.

To set relay configuration values (ACTIVATION):

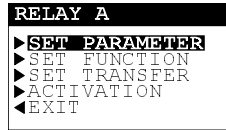

1. With the screen displayed, use ↓ key to select the “ACTIVATION” line.
2. Depending on the selected relay function, pressing ENTER key displays:

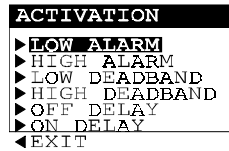

when ALARM relay is selected.

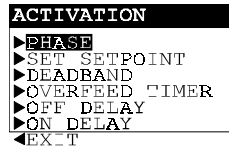

when CONTROL relay is selected.



when TIMER relay is selected.

3. Use ↓ key to select the appropriate relay setting line, and press ENTER key to display its corresponding edit/selection screen.
4. Use the same basic keypad operations described in previous setup procedures to enter the desired value for the displayed relay activation setting.
5. Repeat this procedure for each relay activation setting.

4.6 SET PASSCODE (feature enabled or disabled)

The analyzer has a passcode feature to restrict access to configuration and calibration settings to only authorized personnel.

- **DISABLED:** With the passcode feature disabled, all configuration settings can be displayed and changed, and the analyzer can be calibrated.
- **ENABLED:** With the passcode feature enabled, all configuration settings can be displayed -- but they cannot be changed, and the CALIBRATE and TEST/MAINT menus cannot be calibrated without the passcode. When you attempt to change a setting in the CONFIGURE menu by pressing the **ENTER** key, a displayed notification requests passcode entry. A valid passcode entry saves the changed setting and returns the display to the “MAIN MENU” branch selection screen. An incorrect passcode entry causes the display to momentarily show an error notification before returning to the “MAIN MENU” branch selection screen. There is no limit on attempts to enter a valid passcode.

The passcode is factory-set is to “3 4 5 6.” It cannot be changed.

To enable or disable the passcode feature:

1. Press **MENU** key to display . Use **↓** key to select the “CONFIGURE” line.

1. Press **ENTER** key to display . Use **↓** key to select the “SET PASSCODE” line.

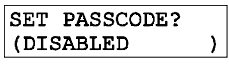
2. Press **ENTER** key to display a screen like . Use **↓** and **↑** keys to view both choices (DISABLED or ENABLED). With the desired choice displayed, press **ENTER** key to enter this selection.

4.7 Configuration Setting Summary

Table B lists all configuration settings and their entry ranges/ choices and factory defaults, categorized by basic functions.

Table B -- ANALYZER CONFIGURATION SETTINGS (RANGES/CHOICES and DEFAULTS)			
Displayed Screen Title	Entry Range or Choices (where applicable)	Factory Default	Your Setting
LANGUAGE Configuration Setting			
LANGUAGE?	ENGLISH, FRENCH, GERMAN, SPANISH, etc.	ENGLISH	
SENSOR Configuration Settings			
DISPLAY FORMAT?	XX.XX ppm or X.XXX ppm	XX.XX ppm	
SET FILTER?	0-60 seconds	0 seconds	
PULSE SUPPRESS?	OFF or ON	OFF	
ENTER NOTE?	Enter up to eight characters to replace OZONE	OZONE	
TEMP ELE: SELECT TYPE?	NTC 100K or MANUAL	NTC 100K	
TEMP ELE: SET MANUAL?	0.0-50.0°C	25.0°C	
TEMPERATURE Display Configuration Setting			
CONFIGURE: °C OR °F?	°C or °F	°C	
ANALOG OUTPUT Configuration Settings			
SET PARAMETER?	SENSOR (ozone) or TEMPERATURE	Output 1: SENSOR Output 2: TEMPERATURE	
SET 4mA VALUE?	SENSOR (ozone): 0-99.99 ppm TEMP: 0.0-50.0°C or 32.0-122.0°F	SENSOR (ozone): 0 ppm TEMP: 0.0°C or 32.0°F	
SET 20mA VALUE?	SENSOR (ozone): 0-99.99 ppm TEMP: 0.0-50.0°C or 32.0-122.0°F	SENSOR (ozone): 99.99 ppm TEMP: 50.0°C or 122.0°F	
SET TRANSFER?	0-20 mA or 4-20 mA	Outputs 1 and 2: 20 mA	
SET FILTER?	0-60 seconds	Outputs 1 and 2: 0 seconds	
SCALE 0mA/4mA?	0 mA or 4 mA	Outputs 1 and 2: 4 mA	
RELAY Configuration Settings			
Settings Common to ALARM and CONTROL Relays:			
SET PARAMETER?	SENSOR (ozone) or TEMPERATURE	Relay A: SENSOR Relay B: TEMPERATURE Relay C: SENSOR Relay D: TEMPERATURE	
SET FUNCTION?	ALARM, CONTROL, STATUS or TIMER	All Relays: ALARM	
SET TRANSFER?	DE-ENERGIZED or ENERGIZED	All Relays: DE-ENERGIZED	
OFF DELAY?	0-300 seconds	0 seconds	
ON DELAY?	0-300 seconds	0 seconds	

(Table B continued on next page.)

Table B -- ANALYZER CONFIGURATION SETTINGS (RANGES/CHOICES and DEFAULTS -- continued)			
Displayed Screen Title	Entry Range or Choices (where applicable)	Factory Default	Your Setting
RELAY Configuration Settings (continued)			
Settings for only ALARM Relays:			
LOW ALARM?	SENSOR (ozone): 0-99.99 ppm TEMP: 0.0-50.0°C or 32.0-122.0°F	SENSOR (ozone): 0 ppm TEMP: 0.0°C or 32.0°F	
HIGH ALARM?	SENSOR (ozone): 0-99.99 ppm TEMP: 0.0-50.0°C or 32.0-122.0°F	SENSOR (ozone): 99.99 ppm TEMP: 50.0°C or 122.0°F	
LOW DEADBAND?	SENSOR (ozone): 0-10% of range TEMP: 0-10% of range	SENSOR (ozone): 0 ppm TEMP: 0.0°C or 0.0°F	
HIGH DEADBAND?	SENSOR (ozone): 0-10% of range TEMP: 0-10% of range	SENSOR (ozone): 0 ppm TEMP: 0.0°C or 0.0°F	
Settings for only CONTROL Relays:			
PHASE?	HIGH or LOW	All Relays: HIGH	
SET SETPOINT?	SENSOR (ozone): 0-99.99 ppm TEMP: 0.0-50.0°C or 32.0-122.0°F	SENSOR (ozone): 99.99 ppm TEMP: 50.0°C or 122.0°F	
DEADBAND?	SENSOR (ozone): 0-10% of range TEMP: 0-10% of range	SENSOR (ozone): 0 ppm TEMP: 0.0°C or 0.0°F	
OVERFEED TIMER?	0-999.9 minutes	0 minutes	
Settings for only TIMER Relays:			
INTERVAL?	0-999.9 minutes	5 minutes	
DURATION?	0-999 seconds	5 seconds	
OFF DELAY?	0-999 seconds	1 second	
PASSCODE Configuration Setting			
SET PASSCODE?	DISABLED or ENABLED	DISABLED	
TEST/MAINT Simulation Function Settings			
SELECT SIM?	SENSOR (ozone) or TEMPERATURE	SENSOR	
SIM SENSOR?	SENSOR: 0-99.99 ppm TEMP: 0.0-50.0°C or 32.0-122.0°F	Present measured value of sensor's selected parameter (ozone or temperature).	

SECTION 5

ANALYZER CALIBRATION

5.1 Important Information

To maintain best measuring accuracy, periodically calibrate the system. Sensor performance slowly degrades over time, eventually causing inaccurate readings. The time period between calibrations, and rate of system drift, can vary considerably with each application and its specific conditions.



Calibration Tip! Establish a maintenance schedule to service the sensor and calibrate the system. The periodic intervals for maintenance (weekly or monthly) will be influenced by the characteristics of the process solution, and can only be determined by operating experience.

In addition to calibrating the system for ozone measurement (Section 5.2), the analyzer provides two methods for calibrating temperature (Section 5.3). The mA values for each analog output can also be calibrated (Section 5.4).



NOTE: When the passcode feature is enabled (Section 4.6), you must successfully enter the passcode before attempting to calibrate the analyzer.

Also, an in-progress calibration can always be aborted by pressing the ESC key. After “ABORT: YES?” screen appears, do one of the following:

- Press **ENTER key** to abort. After the “CONFIRM ACTIVE?” screen appears, press **ENTER key** to return the analog outputs and relays to their active states (MEASURE screen appears).
- Press **↑ or ↓ key** to choose “ABORT: NO?” screen. Press **ENTER key** to continue calibration.



Calibration Tip! If a “CONFIRM FAILURE?” screen appears during calibration, press **ENTER key** to confirm. Then, use **↑ or ↓ key** to select between “CAL: EXIT?” or “CAL: REPEAT?” and do one of the following:

- With the “(CAL: EXIT)” screen selected, press **ENTER key**. After “CONFIRM ACTIVE?” screen appears, press **ENTER key** to return analog outputs and relays to their active states (MEASURE screen appears).

- With the “(CAL: REPEAT)” screen selected, press **ENTER** key to repeat calibration.

5.2 Ozone SAMPLE CAL Calibration

The SAMPLE CAL method enables you to keep the sensor in the process. Or, you could place the sensor in a container holding a sample of the process. Determine the value of the process (or sample) by laboratory analysis or from a comparison reading of a calibrated instrument. Then enter the known ozone concentration value.

1. Keep the sensor in the process or immerse the sensor in a sample. **Allow the sensor and process (or sample) temperatures to equalize.** Depending on their temperature differences, this may take 30 minutes or more.

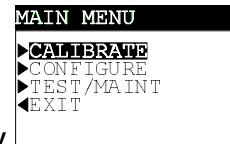

2. Press **MENU** key to display .
3. With the “CALIBRATE” line selected (shown in reverse

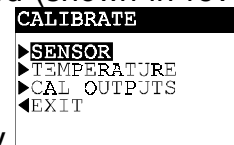

video), press **ENTER** key to display .

4. With the “SENSOR” line selected, press **ENTER** key to

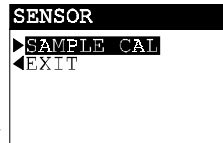

display .

5. With the “SAMPLE CAL” line selected, press **ENTER** key to display . Use **↑** or **↓** key to view the three states that the analog outputs (and relays) can be in during calibration:

- **HOLD OUTPUTS:** Holds their present values.
- **XFER OUTPUTS:** Transfers to preset values.
- **ACTIVE OUTPUTS:** Responds to measured values.

With the desired choice displayed, press **ENTER** key to enter this selection.

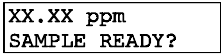
6. With the sensor in the process (or sample) and the  screen showing the active measurement reading, press **ENTER key** to confirm. The “SAMPLE CAL PLEASE WAIT” screen appears, enabling the ozone and temperature signals to stabilize. This may take several minutes.

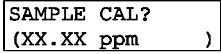
7. After the reading has stabilized, this static  screen appears showing the “last measured” value.



NOTE: *If this screen reads zero, verify that ozone is present. If yes, check to make sure that sensor wiring is correct and intact. If it is, the sensor needs servicing (see PART FOUR, Section 3). When a sensor, even a new sensor, has been inactive for more than 6 weeks, its electrodes begin to tarnish due to lack of operational electrochemical activity, contaminating the electrolyte. For prolonged storage, always store the sensor in a “dry” condition (see PART FOUR, Section 4).*

8. Use **arrow keys** to adjust the displayed value to exactly match the known ozone value.

9. Press **ENTER key** to enter the value and complete calibration (CONFIRM CAL OK?” screen appears).

10. If using a container of process sample, re-install the sensor into the process.

11. Press **ENTER key** to display the active measurement reading on the “CONFIRM ACTIVE?” output status screen. When the reading corresponds to the actual typical process value, press **ENTER key** again to return the analog outputs and relays to their active states (MEASURE screen appears).

This completes “SAMPLE CAL” calibration.

5.3 Temperature Calibration

1 POINT SAMPLE Method

The analyzer is factory-calibrated for accurate temperature measurement. However, “1 POINT SAMPLE” and “2 POINT SAMPLE” methods are provided for temperature calibration.

This method requires a container of water (or process sample) that has a known temperature value approximately equal to the normal operating temperature of the process.

1. Place the Model 5920Z0 ozone sensor into the container of water (or process sample).

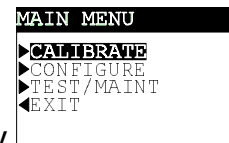

```

MAIN MENU
┆CALIBRATE
┆CONFIGURE
┆TEST/MAINT
┆EXIT
  
```

2. Press **MENU** key to display .
3. With the “CALIBRATE” line selected, press **ENTER** key

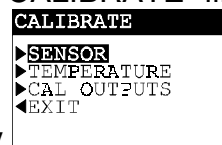

```

CALIBRATE
┆SENSOR
┆TEMPERATURE
┆CAL OUTPUTS
┆EXIT
  
```

to display .

4. Use **↓** key to select the “TEMPERATURE” line, and

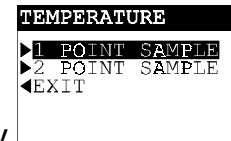

```

TEMPERATURE
┆1 POINT SAMPLE
┆2 POINT SAMPLE
┆EXIT
  
```

press **ENTER** key to display .

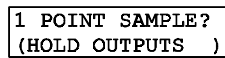
5. With the “1 POINT SAMPLE” line selected, press **ENTER** key to display  . Use **↑** or **↓** key to view the three states that the analog outputs (and relays) can be in during calibration:

- **HOLD OUTPUTS:** Holds their present values.
- **XFER OUTPUTS:** Transfers to preset values.
- **ACTIVE OUTPUTS:** Responds to measured values.

With the desired choice displayed, press **ENTER** key to enter this selection.

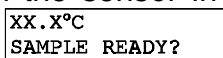
6. With the sensor in the water (or process sample) and the  screen showing the active measurement reading, press **ENTER** key to confirm. After the “1 POINT SAMPLE PLEASE WAIT” screen appears, **allow the water (or process sample) and**



sensor temperatures to equalize. This may take a few minutes.

NOTE: *If the temperature reading is relatively stable, you can manually complete calibration by pressing the **ENTER key** while the “PLEASE WAIT” screen is displayed. However, this is not recommended because the signal may not be exactly stable, resulting in an inaccurate calibration.*

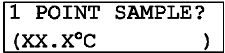
7. After the reading has stabilized, this static  screen appears showing the “last measured” value.
8. Use **↑** and **↓** keys to adjust the displayed value to exactly match the known temperature value.
9. Press **ENTER key** to enter the value and complete calibration (1 POINT SAMPLE: CONFIRM CAL OK?” screen appears).
10. Re-install the sensor into the process.
11. Press **ENTER key** to display the active measurement reading on the “CONFIRM ACTIVE?” output status screen. When the reading corresponds to the actual typical process value, press **ENTER key** to return the analog outputs and relays to their active states (MEASURE screen appears).

This completes “1 POINT SAMPLE” temperature calibration.

2 POINT SAMPLE Method

This method requires a container of ice water and a container of 50°C water.

1. Place the Model 5920Z0 ozone sensor into the container of ice water.

2. Press **MENU key** to display

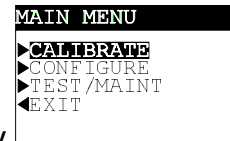

3. With the “CALIBRATE” line selected, press **ENTER key**

```

CALIBRATE
▶SENSOR
▶TEMPERATURE
▶CAL OUTPUTS
◀EXIT
  
```

to display .

4. Use ↓ **key** to select the “TEMPERATURE” line, and

```

TEMPERATURE
▶1 POINT SAMPLE
▶2 POINT SAMPLE
◀EXIT
  
```

press **ENTER key** to display .

5. Use ↓ **key** to select the “2 POINT SAMPLE” line, and press **ENTER key** to display

```
2 POINT SAMPLE?
(HOLD OUTPUTS )
```

. Use ↑ **or** ↓ **key** to view the three states that the analog outputs (and relays) can be in during calibration:

- **HOLD OUTPUTS:** Holds their present values.
- **XFER OUTPUTS:** Transfers to preset values.
- **ACTIVE OUTPUTS:** Responds to measured values.

With the desired choice displayed, press **ENTER key** to enter this selection.

6. With the sensor in the ice water and the

```
XX.X°C
SAMPLE 1 READY?
```

 screen showing the active measurement reading, press **ENTER key** to confirm. After the “2 POINT SAMPLE PLEASE WAIT” screen appears, **allow the ice water and sensor temperatures to equalize**. This may take from a few minutes up to 20 minutes.



NOTE: If the temperature reading is relatively stable, you can manually complete calibration of this point by pressing the **ENTER key** while the “PLEASE WAIT” screen is displayed. However, this is not recommended because the signal may not be exactly stable, resulting in an inaccurate calibration.

7. After the reading has stabilized, this static

```
SAMPLE 1?
(XX.X°C )
```

 screen appears showing the “last measured” value.

8. Use ↑ **and** ↓ **keys** to adjust the displayed value to exactly match the known temperature value.

9. Press **ENTER key** to enter the value, completing calibration of the first point.
10. After the

XX.X°C
SAMPLE 2 READY?

 screen appears (showing the active measurement reading), remove the sensor from the ice water, place it into the 50°C water, and press **ENTER key** to confirm.
11. After the “2 POINT SAMPLE PLEASE WAIT” screen appears, **allow the 50° water and sensor temperatures to equalize**. This may take up to 20 minutes.



NOTE: If the temperature reading is relatively stable, you can manually complete calibration by pressing the **ENTER key** while the “PLEASE WAIT” screen is displayed. However, this is not recommended because the signal may not be exactly stable, resulting in an inaccurate calibration.

12. After the reading has stabilized, this static

SAMPLE 2?
(XX.X°C)

 screen appears showing the “last measured” value.
13. Use **↑ and ↓ keys** to adjust the displayed value to exactly match the known temperature value.
14. Press **ENTER key** to enter the value and complete calibration (“2 POINT SAMPLE: CONFIRM CAL OK?” screen appears).
15. Re-install the sensor into the process.
16. Press **ENTER key** to display the active measurement reading on the “CONFIRM ACTIVE?” output status screen. When the reading corresponds to the actual typical process value, press **ENTER key** to return the analog outputs and relays to their active states (MEASURE screen appears).

This completes “2 POINT SAMPLE” temperature calibration.

5.4 Analog Outputs (1 and 2) Calibration



The analyzer analog outputs are factory-calibrated. However, they can be re-calibrated at any time if desired. **These instructions calibrate Output 1. Calibrate Output 2 in the same way using its respective menu screens.**

NOTE: When the passcode feature is enabled (Section 4.6), you must successfully enter the passcode before attempting to calibrate the analog outputs.

When an output is configured to be 0-20 mA, the analyzer will calibrate the 4 mA and 20 mA values (not the 0 mA value). Also, the analyzer adjustment range for output values during calibration is ± 2 mA.

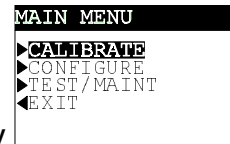

1. Press **MENU** key to display

2. With the “CALIBRATE” line selected (shown in reverse

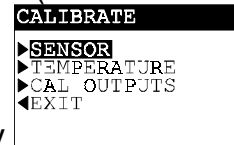

video), press **ENTER** key to display

3. Use **↓** key to select the “CAL OUTPUTS” line, and

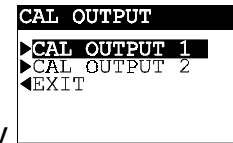

press **ENTER** key to display

4. With the “CAL OUTPUT 1” line selected, press **ENTER**

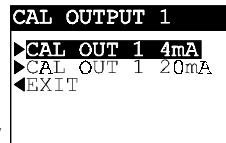

key to display

5. With the “CAL OUT 1 4 mA” line selected, press

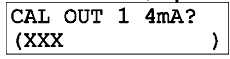
ENTER key to display a screen like . The displayed value is “counts” -- not mA -- that dynamically change as the output is adjusted.

6. Use a calibrated digital multimeter to measure Output 1’s actual minimum value provided at Terminals 1 and 2 on TB1.

7. Use **arrow keys** to adjust Output 1's minimum value to read exactly "4.00 mA" on the digital multimeter -- not the analyzer display, and press **ENTER key** to complete calibration of the minimum endpoint value.

```

CAL OUTPUT 1
▶CAL OUT 1 4mA
▶CAL OUT 1 20mA
◀EXIT

```

8. After the screen re-appears, press **↓ key once** to select the "CAL OUT 1 20 mA" line, and press **ENTER key** to display a screen like

```
CAL OUT 1 20mA?
(XXXX )
```

. Once again the displayed value is "counts" -- not mA -- that dynamically change when the output is adjusted.
9. Use a calibrated digital multimeter to measure Output 1's actual maximum value.
10. Use **arrow keys** to adjust Output 1's maximum value to read exactly "20.00 mA" on the digital multimeter -- not the analyzer display, and press **ENTER key** to complete calibration of the maximum endpoint value.

This completes analog Output 1 calibration.

SECTION 6

TEST/MAINTENANCE

The analyzer has TEST/MAINT menu screens to:

- Check system status for analyzer, sensor/temperature inputs, and relays, including TIMER relay countdown.
- Test sensor operation (in air).
- Hold analog outputs at their last measured values.
- Manually reset all relay overfeed timers at once.
- Provide analog output test signals to confirm operation of connected devices.
- Test relay operation (energize or de-energize).
- Identify analyzer EPROM version.
- Simulate ozone or temperature value to exercise the measurement loop.
- Reset configuration -- not calibration -- values to defaults.
- Reset calibration -- not configuration -- values to defaults.

6.1 STATUS Checking (analyzer, sensor, and relays)

The system diagnostic capabilities of the analyzer enable you to check the operating status of the analyzer, sensor and temperature inputs, and relays. The MEASURE screen will flash the “WARNING CHECK STATUS” message when a system diagnostic “fail” condition has been detected. To determine the condition causing the warning, display the “STATUS” screens:

```

MAIN MENU
▶CALIBRATE
▶CONFIGURE
▶TEST/MAINT
▶EXIT
  
```

1. Press **MENU** key to display
2. Use **↓** key to select the “TEST/MAINT” line.

```

TEST/MAINT
▶STATUS
▶SENSOR AIR TEST
▶HOLD OUTPUTS
▶OVERFEED RESET
▶OUTPUT 1
▶OUTPUT 2
▶RELAY A
▶RELAY B
▶RELAY C
▶RELAY D
▶EPROM VERSION
▶SELECT SIM
▶SIM SENSOR
▶RESET CONFIGURE
▶RESET CALIBRATE
▶EXIT
  
```

3. Press **ENTER** key to display
4. With the “STATUS” line selected, press **ENTER** key to display the “STATUS: ANALYZER OK” screen. This screen confirms that the analyzer is operating properly. If “FAIL” appears, it may mean:

- EPROM failure (data is not valid).
 - Scaling card not present or not recognized.
 - Analog-to-digital converter not responding.
 - RAM failure.
 - Internal serial communications failure.
5. Press **ENTER key** once to view the “STATUS: SENSOR OK” screen. Then press the **ENTER key** again to view the “STATUS: TEMP OK” screen. If FAIL appears on either input status screen, it may indicate:
- Sensor needs servicing (punctured membrane, dirty electrodes, and/or depleted electrolyte).
 - Sensor is disconnected or incorrectly wired.
 - Signal is very noisy or exceeds measuring range.
6. With the “STATUS: TEMP OK” screen displayed, press **ENTER key** once to view the “STATUS: RLY A” screen. Subsequent **ENTER key** presses display status screens for Relays B, C, and D. Status indications can be:

Status Indication	Meaning
ACTIVE (Relay energized; annunciator is on.)	Control Relay: Measured value exceeds setpoint. Alarm Relay: Measured value exceeds low or high alarm point. Status Relay: Existing system diagnostic condition has been detected.
INACTIVE (Relay not energized; annunciator is off.)	Control Relay: Measured value does not exceed setpoint. Alarm Relay: Measured value does not exceed low or high alarm point. Status Relay: Analyzer has not detected system diagnostic condition.
TIMEOUT (Relay not energized; annunciator is blinking.)	Control Relay: Overfeed timer has timed out; manually reset it. NOTE: TIMEOUT only applies to control relays.
COUNTING (Relay energized; annunciator is on.)	Control Relay: Overfeed timer is counting, but has not timed out. NOTE: COUNTING only applies to control relays.
TIME ON (Relay energized; annunciator is on.)	Timer Relay: Timer relay is on and counting down duration time before turning off. NOTE: TIME ON only applies to timer relays.
TIME OFF (Relay not energized; annunciator is off.)	Timer Relay: Timer relay is off and counting down interval time before turning on. NOTE: TIME OFF only applies to timer relays.

7. To end status checking, press **ENTER** or **ESC key** (display returns to TEST/MAINT top-level menu screen).

6.2 SENSOR AIR TEST



This test can only be performed when the sensor is completely dry and held in dry air.

Important SENSOR AIR TEST Tip! Dry the electrode end of the sensor completely. This requires disassembling the sensor components located above the membrane. The protection cap components include two Tefzel washers, steel grill, Dacron mesh, and one silicone washer as shown in Figure 5-1. No water, not even one drop, can be on these components or on the threads of the protection cap and sensor head. Any residual water will create an impermeable layer over the membrane, making it impossible to properly test the sensor.

1. Remove the sensor from the process and thoroughly dry the sensor components as described in the above "Important SENSOR AIR TEST Tip!" Refer to PART FOUR, Section 3.3 for details to remove the sensor protection cap.

```

TEST/MAINT
▶STATUS
▶SENSOR AIR TEST
▶HOLD OUTPUTS
▶OVERFEED RESET
▶OUTPUT 1
▶OUTPUT 2
▶RELAY A
▶RELAY B
▶RELAY C
▶RELAY D
▶EPROM VERSION
▶SELECT SIM
▶SIM SENSOR
▶RESET CONFIGURE
▶RESET CALIBRATE
◀EXIT

```

2. With the screen displayed, use ↓ key to select the "SENSOR AIR TEST" line, and press ENTER key to display `SENSOR AIR TEST?`
`(HOLD OUTPUTS)`. Use ↑ or ↓ key to view the three states that the analog outputs (and relays) can be in during this test:

- **HOLD OUTPUTS:** Holds their present values.
- **XFER OUTPUTS:** Transfers to preset values.
- **ACTIVE OUTPUTS:** Responds to measured values.

With the desired choice displayed, press ENTER key to enter this selection.

3. With the "SENSOR AIR TEST: IN DRY AIR" screen displayed and the sensor held in dry air, press ENTER key to display `IN AIR: X.X%`
`OF IDEAL VALUE`. The displayed value shows the percentage of sensor sensitivity as compared to the theoretical sensitivity of an "ideal" sensor. The reading will typically increase from 0% to over 200% as the sensor polarizes, eventually decreasing



and stabilizing between 70% and 130%. This will take approximately 2 to 10 minutes.

NOTE: *If the reading does not increase to approximately 200%, sensor components may not be completely dry. Refer to the “Important SENSOR AIR TEST Tip!” at the beginning of this subsection for details. Also, see PART FOUR, Section 3.3 to remove the sensor protection cap.*

Any stable reading outside of the 70-130% acceptable range indicates that the sensor needs immediate servicing. This may include cleaning electrodes, replacing electrolyte, and/or installing a new membrane if it is punctured or not properly seated. See PART FOUR, Section 3 for complete details.

If the reading is relatively close to either limit, immediate servicing is not required but will eventually be needed. Only operating experience and process conditions will ultimately determine at which time the sensor needs servicing.

4. After evaluating this data, press **ENTER key** to display

OZONE: X.XX ppm
CONFIRM ACTIVE?

. This “CONFIRM ACTIVE?” screen shows the active measurement reading. Place the sensor back into the process. When the reading corresponds to the actual typical process value, press **ENTER key** to return the analog outputs and relays to their active states (MEASURE screen appears).

CAUTION:

THE READING, REFLECTING SENSOR RECOVERY TIME, MAY TAKE FROM 1 TO 24 HOURS TO REACH THE TYPICAL PROCESS VALUE. THE TIME IS DEPENDENT ON THE PROCESS OZONE CONCENTRATION. WHEN OZONE CONCENTRATION IS HIGHER, THE TIME DECREASES. WHEN LOWER, THE TIME INCREASES.

5. After performing the SENSOR AIR TEST and correcting any sensor problems, calibrate the analyzer using the SAMPLE CAL procedure in PART THREE, Section 5.2.

This completes the SENSOR AIR TEST.

6.3 HOLD OUTPUTS

The analyzer has a convenient feature to hold the analog outputs at their last measured values for up to 30 minutes, suspending operation of any connected devices.

```

TEST/MAINT
▶STATUS
▶SENSOR AIR TEST
▶HOLD OUTPUTS
▶OVERFEED RESET
▶OUTPUT 1
▶OUTPUT 2
▶RELAY A
▶RELAY B
▶RELAY C
▶RELAY D
▶EPROM VERSION
▶SELECT SIM
▶SIM SENSOR
▶RESET CONFIGURE
▶RESET CALIBRATE
◀EXIT
  
```

1. With the  screen displayed, use **↓ key** to select the “HOLD OUTPUTS” line.
2. Press **ENTER key** to immediately hold the analog outputs (“HOLD OUTPUTS: ENTER TO RELEASE” screen appears, acknowledging that hold has occurred).

NOTE: *If the keypad is not used within 30 minutes, the analog outputs will automatically change back to their active states and the display will return to the MEASURE screen.*

3. To end hold at any time and return the analog outputs back to their “active” states, press **ENTER key** (display returns to TEST/MAINT top-level menu screen).

6.4 OVERFEED RESET (relay timers)

When a relay overfeed timer “times out,” as indicated by its blinking annunciator, the timer must be manually reset using TEST/MAINT menu screens. The relay annunciator stops blinking after reset. **All overfeed timers are manually re-set at once.**

```

TEST/MAINT
▶STATUS
▶SENSOR AIR TEST
▶HOLD OUTPUTS
▶OVERFEED RESET
▶OUTPUT 1
▶OUTPUT 2
▶RELAY A
▶RELAY B
▶RELAY C
▶RELAY D
▶EPROM VERSION
▶SELECT SIM
▶SIM SENSOR
▶RESET CONFIGURE
▶RESET CALIBRATE
◀EXIT
  
```

1. With the  screen displayed, use **↓ key** to select the “OVERFEED RESET” line.
2. Press **ENTER key** to display “OVERFEED RESET” screen. To reset all overfeed timers at once, press **ENTER key** again (“OVERFEED RESET: DONE” screen appears, acknowledging reset has occurred).

6.5 OUTPUT (1 and 2) Analog Test Signals

- To return to the TEST/MAINT top-level menu screen, press **ESC key** or **ENTER key**.

The analyzer can provide analog output test signals of a desired mA value to confirm operation of connected devices. **These instructions only provide an Output 1 test signal. Provide an Output 2 test signal in the same way using its respective menu screens.**

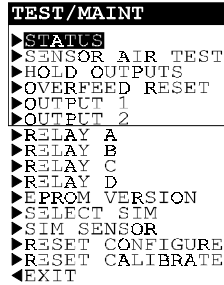

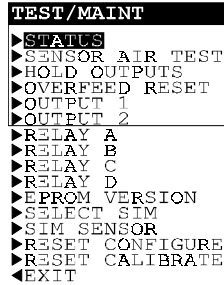
- With the  screen displayed, use **↓ key** to select the “OUTPUT 1” line.

- Press **ENTER key** to display a screen like

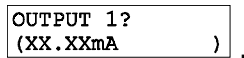

NOTE: The mA output test signal is now active. Its value is shown on this screen.

- Use **arrow keys** to adjust the displayed value to obtain the desired mA test signal at Output 1 terminals.
- To remove the output test signal and return to the TEST/ MAINT top-level menu screen, press **ESC key** or **ENTER key**.

6.6 RELAY (A, B, C, and D) Operating Test

Relays A, B, C, and D can be tested to confirm their operation. **These instructions only test Relay A. Test other relays in the same way using their respective menu screens.**

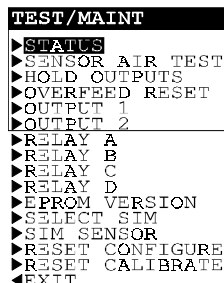

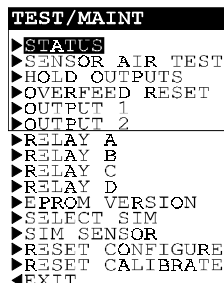
- With the  screen displayed, use **↓ key** to select the “RELAY A” line.

2. Press **ENTER key** to display RELAY A?
(ENERGIZE) . Relay A should be energized. Confirm this by checking the NO and NC relay output terminals with a continuity meter.
3. Press **↑ or ↓ key once** to display RELAY A?
(DE-ENERGIZE) . Relay A should now be de-energized. Confirm this by checking the NO and NC relay output terminals with a continuity meter.
4. To end this test and return to the TEST/MAINT top-level menu screen, press **ESC key** or **ENTER key**.

6.7 EPROM VERSION Checking

You can check the version of EPROM used in the analyzer.

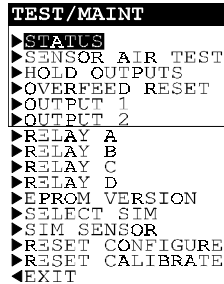

1. With the RELAY A?
(ENERGIZE) screen displayed, use **↓ key** to select the “EPROM VERSION” line.
2. Press **ENTER key** to view the EPROM version screen.
3. To return to the TEST/MAINT top-level menu screen, press **ESC key** or **ENTER key**.

6.8 SELECT SIM Measurement

You can simulate a measured value to make the relays and analog outputs respond accordingly. First, select the type of simulated value using this subsection. Then, set the desired simulation value following the steps in subsection 6.9.

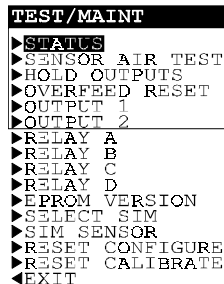

1. With the RELAY A?
(ENERGIZE) screen displayed, use **↓ key** to select the “SELECT SIM” line.
2. Press **ENTER key** to display a screen like SELECT SIM?
(SENSOR) . Use **↓ and ↑ keys** to view all choices:

- **SENSOR:** Selects the simulated value to be an ozone concentration value.
- **TEMPERATURE:** Selects the simulated value to be a temperature value.

3. With the desired choice displayed, press **ENTER** key to enter this selection and return to the TEST/MAINT top-level menu screen.

6.9 SIM SENSOR Setting

After selecting the type of simulated measurement (subsection 6.8), set the desired simulation value.

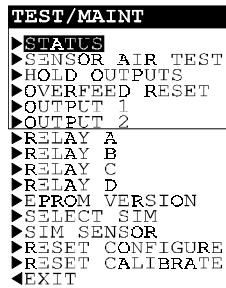

1. With the screen displayed, use **↓** key to select the “SIM SENSOR” line.
2. Press **ENTER** key to display a screen like

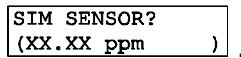

NOTE: Both analog output signals are now active. They have a mA value that corresponds to the measurement value shown on this screen. (The relays, depending on their configured settings, may also respond to this simulation value.)

3. Use **arrow** **←** keys to adjust the displayed simulation value to the desired value.
4. To end simulation and return to the TEST/MAINT top-level menu screen, press **ESC** key or **ENTER** key.

6.10 RESET CONFIGURE Values to Factory Defaults

You can simultaneously reset stored configuration settings to factory-set defaults (see Table B). **This excludes calibration settings.**

```

TEST/MAINT
▶STATUS
▶SENSOR AIR TEST
▶HOLD OUTPUTS
▶OVERFEED RESET
▶OUTPUT 1
▶OUTPUT 2
▶RELAY A
▶RELAY B
▶RELAY C
▶RELAY D
▶EPROM VERSION
▶SELECT SIM
▶SIM SENSOR
▶RESET CONFIGURE
▶RESET CALIBRATE
◀EXIT

```

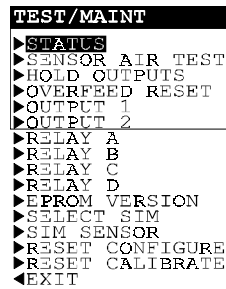
1. With the  screen displayed, use **↓ key** to select the “RESET CONFIGURE” line.
2. Press **ENTER key** to display the “RESET CONFIGURE: ARE YOU SURE?” screen, asking if you really intend to perform this extreme action. (If you want to abort this action, press **ESC key** now.)
3. Press **ENTER key** to reset all stored configuration settings -- not calibration settings -- to factory defaults. The “RESET CONFIGURE: DONE” screen appears, acknowledging that reset has occurred.
4. To return to the TEST/MAINT top-level menu screen, press **ESC key** or **ENTER key**.

6.11 RESET CALIBRATE Values to Factory Defaults

You can conveniently reset stored calibration settings to factory-set defaults. **This excludes all other configuration settings.**

```

TEST/MAINT
▶STATUS
▶SENSOR AIR TEST
▶HOLD OUTPUTS
▶OVERFEED RESET
▶OUTPUT 1
▶OUTPUT 2
▶RELAY A
▶RELAY B
▶RELAY C
▶RELAY D
▶EPROM VERSION
▶SELECT SIM
▶SIM SENSOR
▶RESET CONFIGURE
▶RESET CALIBRATE
◀EXIT

```

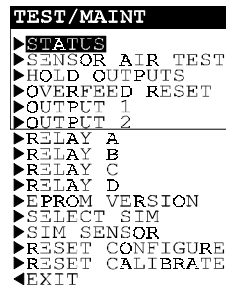
1. With the  screen displayed, use **↓ key** to select the “RESET CALIBRATE” line.
2. Press **ENTER key** to display the “RESET CALIBRATE: ARE YOU SURE?” screen, asking if you really intend to perform this extreme action. (If you want to abort this action, press **ESC key** now.)
3. Press **ENTER key** to reset stored calibration settings -- not configuration settings -- to factory defaults. The “RESET CALIBRATE: DONE” screen appears, acknowledging that reset has occurred.
4. To return to the TEST/MAINT top-level menu screen, press **ESC key** or **ENTER key**.

SECTION 7

RELAY OVERFEED TIMER FEATURE

7.1 Why Use an Overfeed Timer

The useful relay overfeed timer feature, **only available to a CONTROL relay**, is described in more detail in this section.

Suppose that you configure a CONTROL relay with a high phase to operate in response to increasing measured value. The CONTROL relay will then turn on whenever the measured value exceeds its preset setpoint. When the measured value decreases below the setpoint by an amount you preset (the deadband setting), the relay will turn off. But what if a damaged sensor or a process upset condition keeps the measured value above the setpoint or deadband setting? The control element (valve, pump, etc.) switched by that relay would then continue to operate. Depending on the application control scheme, this may excessively dispense costly chemical additives or overly drain or divert the process. Also, the control element itself could be damaged due to excessive continuous or unusual operation such as a pump that is running dry. The useful overfeed timer prevents undesirable conditions like these from happening. It restricts how long the relay and its connected control element will remain on regardless of conditions.

7.2 Configuring Relay Overfeed Timers

To set a relay overfeed timer, use its respective configuration menu screen. The time you set to restrict how long the relay stays on (0-999.9 minutes) should be just enough to provide acceptable results. An excessive setting may waste chemicals or the process itself. Initially, set this time as an estimate. Then, by experimenting and observing the response, periodically “fine tune” to optimize the setting.

7.3 Overfeed Timer “Timeout” Operation

When a CONTROL relay is on and its overfeed timer “times out,” its annunciator will blink. This indicates that the relay is now off and will remain off until you manually reset the overfeed timer. After reset, the relay annunciator stops blinking. (All overfeed timers are reset simultaneously.)

7.4 Resetting Overfeed Timers

To manually reset all relay overfeed timers, please refer to PART THREE, Section 6.4.

7.5 Interactions with Other Analyzer Functions

A relay overfeed timer can, and often will, interact with other analyzer functions while those functions are in use. Table C on the next page explains common overfeed timer interactions.

Table C -- RELAY OVERFEED TIMER INTERACTIONS WITH OTHER ANALYZER FUNCTIONS		
Function Conditions		Resulting Action of Overfeed Timer
Manually Holding Relay Operation (when outputs are held at start of calibration)		
Off relay held in "off"	Overfeed timer was off	Overfeed timer remains off. After you change back to ACTIVE from the HOLD mode, the overfeed timer will remain off until the measured value (or a value you simulate) causes the relay to turn on.
On relay held in "on"	Overfeed timer was counting	Overfeed timer continues its "count down" until it turns the relay off. If you release HOLD <u>before</u> the timer "times out," the timer continues its "count down" until it turns the relay off or the timer automatically resets when the measured value (or a value you simulate) causes the relay to turn off. If you release HOLD <u>after</u> the timer has "timed out," it must be manually reset (PART THREE, Section 6.4).
On relay held in "on"	Overfeed timer was timed out	Overfeed timer remains off which keeps the relay turned off. You must manually reset the relay overfeed timer (PART THREE, Section 6.4).
Manually Transferring Relay Operation (when outputs are transferred at start of calibration)		
Off relay is transferred to "on"	Overfeed timer was off	Overfeed timer starts its "count down" until it turns the relay off. After you change the "on" relay back to "off," the overfeed timer automatically resets.
On relay is transferred to "off"	Overfeed timer was counting	Overfeed timer automatically resets. After you change the "off" relay back to "on," the overfeed timer starts its "count down" until it turns the relay off, or the timer automatically resets again when the measured value (or a value you simulate) causes the relay to turn off.
On relay is transferred to "off"	Overfeed timer was timed out	
Manually Testing Relay Operation (using TEST/MAINT menu screens)		
Off relay is changed to "on"	Overfeed timer was off	Overfeed timer starts its "count down" until it turns the relay off. After you change the "on" relay back to "off," the overfeed timer automatically resets.
On relay is changed to "off"	Overfeed timer was counting	Overfeed timer automatically resets. After you change the "off" relay back to "on," the overfeed timer starts its "count down" until it turns the relay off, or the timer automatically resets again when the measured value (or a value you simulate) causes the relay to turn off.
On relay is changed to "off"	Overfeed timer was timed out	
Operating a Relay By Simulating a Value (using TEST/MAINT menu screens)		
Off relay is turned "on" by simulated value	Overfeed timer was off	Overfeed timer starts its "count down" until it turns the relay off. After you change the "on" relay back to "off," the overfeed timer automatically resets.
On relay is turned "off" by simulated value	Overfeed timer was counting	Overfeed timer automatically resets. After you change the "off" relay back to "on," the overfeed timer starts its "count down" until it turns the relay off, or the timer automatically resets again when the measured value (or a value you simulate) causes the relay to turn off.
On relay is turned "off" by simulation value	Overfeed timer was timed out	

SECTION 8

HART OPTION

8.1 Introduction

Your GLI analyzer may be equipped with the HART[®] Field Communications Protocol option for two-way digital communication. This option enables you to configure the analyzer and retrieve its measured data by using:

- A hand-held terminal such as a HART Communicator Model 275 (or other HART[®]-compatible configurator) containing GLI Device Specific Command sets in its non-volatile memory
- An IBM-compatible PC with appropriate HART[®] Field Communications Protocol software



NOTE: Any generic hand-held terminal can also communicate with a GLI HART-equipped analyzer, with limited operability, using HART Protocol Universal Commands and/or Common Practice Commands.

The hand-held terminal or PC must be connected to the analyzer 4-20 mA analog Output 1 signal anywhere along the circuit wiring. See subsections 8.3 or 8.4 for details.

HART Information Reference Listings

To obtain complete information on the HART Field Communications Protocol, contact:

HART Communication Foundation
9390 Research Blvd, Suite II-250
Austin, Texas 78759 USA

Telephone: [512] 794-0369
Fax: [512] 794-8893
Website: www.hartcomm.org

For information on the HART Communicator Model 275, contact:

Fisher-Rosemount Systems
12000 Portland Avenue South
Burnsville, Minnesota 55337-1535 USA

Headquarters: [612] 895-2000
Service: [800] 654-7768
Fax: [612] 895-2244

8.2 Analyzer Operating Modes for HART Network

HART enables simultaneous analog and digital communication. The analyzer can be operated in a SINGLE MODE or MULTI-DROP mode on a HART network. **An analyzer switch setting selects the mode.**

When the analyzer is set to operate in the SINGLE (Point-to-Point) MODE, as set by the factory, HART preserves the integrity of the 4-20 mA analog Output 1 signal for normal use while enabling two-way digital communication between a single analyzer and querying device(s). The analog signal represents the measured process value. The digital signal, encoded onto the analog signal, can be used to:

- Perform all available analyzer functions (presently, only when using a HART Communicator Model 275).
- Calibrate, configure and acquire all analyzer settings, and retrieve analog output values and measured process value(s).
- Assign device preferences such as a tag, descriptor, message, and date field (for example, to show last calibration date).
- Acquire device information such as analyzer model number, identification number, distributor, etc.
- Acquire HART information including polling address and number of required preambles.

A HART-equipped “smart” GLI analyzer can also be selected to operate in an all-digital MULTI-DROP mode. This enables you to connect multiple analyzers -- all set for MULTI-DROP operating mode -- to the querying device(s) using a common 4-20 mA output cable, creating an efficient multi-analyzer two-way digital communications network.



NOTE: *In the MULTI-DROP mode, the 4-20 mA analog Output 1 signal of each analyzer becomes dedicated only for network use and cannot be used as a normal output.*

Set for either SINGLE MODE or MULTI-DROP operation, the GLI analyzer is always a “slave,” responding to commands received from the “master.” The master can be a hand-held terminal or an IBM-compatible computer with HART-capable software (or software including GLI Device Specific Command sets). The GLI analyzer never initiates a command sequence, but always responds to commands from the master. Up to two master devices may be

connected to each HART loop. Typically, the primary master is a management system or a PC, while the secondary master is usually a hand-held terminal.



NOTE: All HART-equipped GLI analyzers are supplied with their **SINGLE MODE/MULTI-DROP** switch set to the **SINGLE MODE** position to preserve analog Output 1 for normal use.

To set the analyzer operating mode for the HART network, locate the **SINGLE MODE/MULTI-DROP** switch (Figure 3-2) and set it to the desired mode:

- **SM** (left) position for SINGLE MODE
- **MD** (right) position for MULTI-DROP mode

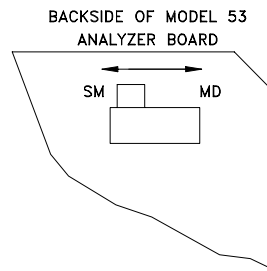

FIGURE 3-2 Location of SINGLE MODE/MULTI-DROP Switch (HART-equipped analyzers only)

8.3 SINGLE MODE (Point-to-Point) Wiring Arrangement

When the GLI analyzer is set to operate in the SINGLE (Point-to-Point) MODE on a HART network, the master(s) is intended to communicate with only a single analyzer. Refer to Figure 3-3 and connect all devices, including up to two masters, to the 4-20 mA analog Output 1 signal.

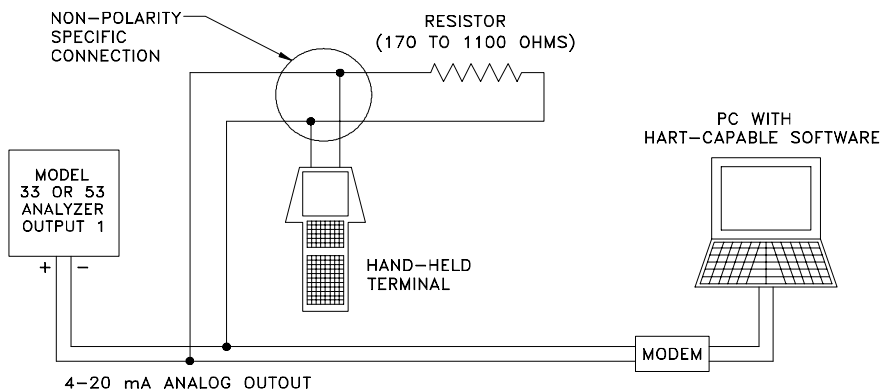

FIGURE 3-3 HART SINGLE MODE (Point-to-Point) Wiring Connections (for single analyzer)

8.4 MULTI-DROP Wiring Arrangement



When the GLI analyzer is set to operate in the MULTI-DROP mode on a HART network, the master(s) is intended to communicate with multiple analyzers.

NOTE: When analyzers are operated in the MULTI-DROP mode, the 4-20 mA analog OUTPUT 1 signal of each analyzer is dedicated only for network use -- not its normal use. (During startup, each analyzer is assigned a non-zero polling address, causing its Output 1 to automatically provide a constant 4 mA signal.) Each analyzer's analog OUTPUT 2, however, remains available for normal use.

1. Make sure the **SINGLE MODE/MULTI-DROP** switch of each analyzer is set to the **MD** (right) position.
2. Refer to Figure 3-4 and connect the 4-20 mA analog Output 1 signal of each analyzer in parallel on one cable, matching polarity as shown.
3. Connect an appropriately-sized power supply in parallel with the analog Output 1 signal, matching polarity as shown.
4. Up to two masters can be connected to the 4-20 mA analog Output 1 signal cable.

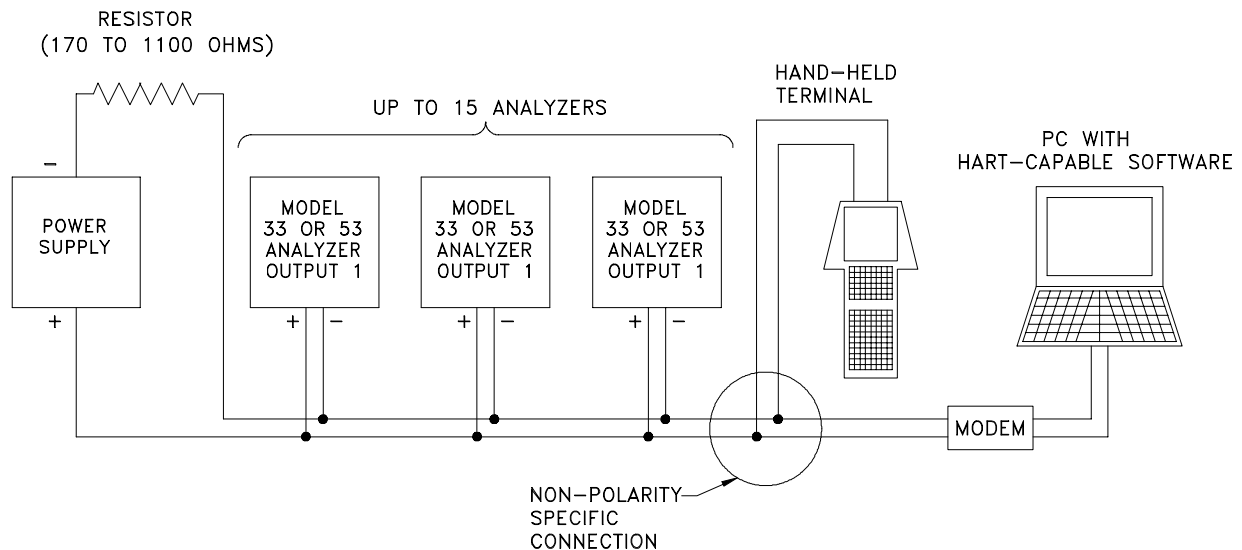

FIGURE 3-4 HART MULTI-DROP Wiring Connections (for multiple analyzer network)

8.5 HART Preferences Setup

Use a hand-held HART terminal or HART-capable PC to set HART preference information. When using a Model 275 HART Communicator to access preference menus, select the “GLI SETUP” line in the MAIN MENU screen and press the → **key** to show this screen on the hand-held terminal:



Use the “HART INFO” submenu to:

- Change the polling address used by the master to identify a device (analyzer).
- View the number of preambles required by a device (analyzer) from the master.

Changing Polling Address

1. With the “GLI SETUP” top-level menu screen displayed, select the “HART INFO” line and press → **key**.
2. With the “HART INFO” submenu screen displayed, select the “Poll addr” line and press the → **key** to display its related screen.
3. Assign a polling address of “0” for one analyzer in a point-to-point configuration, or 1 through 15 for two or more analyzers in a multi-drop configuration. Use the alphanumeric keys to directly select the number, or the arrow keys to adjust the number digit by digit.
4. Press the **F4 key** to enter the polling address, and the **F2 key** to send the polling address to the analyzer.

Viewing Number of Required Preambles

The “Num req preams” information screen shows the number of preambles required by the analyzer from the master.

1. With the “GLI SETUP” top-level menu screen displayed, select the “HART INFO” line and press → **key**.

8.6 Device Preferences Setup

2. With the “HART INFO” submenu screen displayed, select the “Num req preams” line and press the → **key** to display its related information screen.
3. Press the **F4 key** to return to the “HART INFO” submenu screen.

Using a hand-held HART terminal or HART-capable PC, set device (analyzer) preference information.

When using a Model 275 HART Communicator, the “DEVICE INFO” submenu enables you to:

- View the final assembly number of a device.
- View the model number of a device.
- View the manufacturer name of a device.
- Assign a tag associating a device with its installation.
- Assign a descriptor that is associated to a device.
- Assign a message that is associated to a device.
- Assign a user-defined date.
- View the identification number of a device.
- View the revision number(s) of a device.

Viewing Final Assembly Number

The “Final assembly num” information screen shows the final assembly number of the analyzer.

1. With the “GLI SETUP” top-level menu screen displayed, select “DEVICE INFO” line and press → **key**.
2. With the “DEVICE INFO” submenu screen displayed, select the “Final assembly num” line and press the → **key** to display its related information screen.
3. Press the **F4 key** to return to the “DEVICE INFO” submenu screen.

Viewing Model Number

The “Model” information screen shows the model number of the analyzer.

1. With the “GLI SETUP” top-level menu screen displayed, select “DEVICE INFO” line and press → **key**.

2. With the “DEVICE INFO” submenu screen displayed, select the “Model Type” line and press the → **key** to display its related information screen.
3. Press the **F4 key** to return to the “DEVICE INFO” submenu screen.

Viewing Manufacturer

The “Manufacturer” information screen shows the company that manufactured the analyzer.

1. With the “GLI SETUP” top-level menu screen displayed, select “DEVICE INFO” line and press → **key**.
2. With the “DEVICE INFO” submenu screen displayed, select the “Manufacturer” line and press the → **key** to display its related information screen.
3. Press the **F4 key** to return to the “DEVICE INFO” submenu screen.

Assigning a Tag

A tag is text that associates a device with its installation. Though a tag can be used in any way, there are several recommended uses. For example, the tag can be a unique label for a facility that corresponds to a device label, such as a facility drawing or a control system. The tag can also be used as a type of data link layer address.

1. With the “GLI SETUP” top-level menu screen displayed, select “DEVICE INFO” line and press → **key**.
2. With the “DEVICE INFO” submenu screen displayed, select the “Tag” line and press the → **key** to display its related screen.
3. Assign a tag. Use the alphanumeric keys to directly create the text, or the arrow keys to adjust the text character by character.
4. Press the **F4 key** to enter the tag, and the **F2 key** to send the tag to the analyzer.

Assigning a Descriptor

A descriptor is text that is associated to a device. It can be used in any imaginable way.

1. With the “GLI SETUP” top-level menu screen displayed, select “DEVICE INFO” line and press → **key**.
2. With the “DEVICE INFO” submenu screen displayed, select the “Descriptor” line and press the → **key** to display its related screen.
3. Assign a descriptor. Use the alphanumeric keys to directly create the text, or the arrow keys to adjust the text character by character.
4. Press the **F4 key** to enter the descriptor, and the **F2 key** to send the descriptor to the analyzer.

Assigning a Message

A message is text that is associated to a device. It can be used in any imaginable way.

1. With the “GLI SETUP” top-level menu screen displayed, select “DEVICE INFO” line and press → **key**.
2. With the “DEVICE INFO” submenu screen displayed, select the “Message” line and press the → **key** to display its related screen.
3. Assign a message. Use the alphanumeric keys to directly create the text, or the arrow keys to adjust the text character by character.
4. Press the **F4 key** to enter the message, and the **F2 key** to send the message to the analyzer.

Assigning User-defined Date

The “Date” information screen shows a user-defined date that can be used in any imaginable way.

1. With the “GLI SETUP” top-level menu screen displayed, select “DEVICE INFO” line and press → **key**.
2. With the “DEVICE INFO” submenu screen displayed, select the “Date” line and press the → **key** to display its related information screen.

Viewing
Identification (ID)

3. Assign a date.
4. Press the **F4 key** to enter the date, and the **F2 key** to send the date to the analyzer.

The “Device id” information screen shows the number that uniquely identifies the analyzer. The ID number cannot be changed by the communicator (master).

1. With the “GLI SETUP” top-level menu screen displayed, select “DEVICE INFO” line and press → **key**.
2. With the “DEVICE INFO” submenu screen displayed, select the “Device id” line and press the → **key** to display its related information screen.
3. Press the **F4 key** to return to the “DEVICE INFO” submenu screen.

Viewing Revisions

The “DEVICE REVISION” line enables access to three revision level information screens:

- Universal Rev: Revision of the universal device description that the analyzer conforms to.
 - Fld Device Rev: Revision of the analyzer-specific description that the analyzer conforms to.
 - Software Rev: Revision of the software (firmware) that is embedded in the analyzer.
1. With the “GLI SETUP” top-level menu screen displayed, select “DEVICE INFO” line and press → **key**.
 2. With the “DEVICE INFO” submenu screen displayed, select the “Device revision” line and press the → **key**.
 3. With the “DEVICE REVISION” sub-submenu screen displayed, select the appropriate line and press the → **key** to display its related information screen.
 4. Press the **F4 key** to return to the “DEVICE INFO” submenu screen.

8.7 “Master Reset” Function

HART enables you to reset the GLI analyzer to factory-default values using the “GLI SETUP” menu of the master. The execution of this command may take a relatively long time to complete. Consequently, the analyzer cannot respond to other commands until reset is complete.

1. With the “GLI SETUP” top-level menu screen displayed, select “MASTER RESET” line and press → **key**.
2. After the “MASTER RESET” submenu screen appears, select the “Yes” line.
3. Press the **F4 key** to execute master reset and to return to the “GLI SETUP” top-level menu screen.

8.8 “Refresh” Function

The “REFRESH” function enables you to initiate HART to resynchronize the master to the GLI analyzer in case changes made at the analyzer are not reflected by the hand-held terminal.



NOTE: *Since HART only performs housekeeping tasks upon initialization, the “REFRESH” function need only be performed once. However, it may be used anytime thereafter to refresh the variables in the master.*

1. With the “MAIN MENU” top-level menu screen displayed, select the “REFRESH” line and press → **key**.
2. A “Please wait...” message will be displayed until the master has finished retrieving variables from the analyzer. Thereafter, the display will be returned to the “MAIN MENU” top-level screen.

8.9 Protocol Command Set for PC Programming

The Universal Commands and some Common Practice commands inherent in the HART protocol can be used for limited operability. The Device Specific Command set for all existing GLI analyzers is available on request for creating a full-featured HART-capable program to run on an IBM-compatible PC.

PART FOUR - SERVICE AND MAINTENANCE

SECTION 1

GENERAL INFORMATION

1.1 Inspecting Sensor Cable

If a measurement problem exists and you suspect the sensor cable, inspect it for physical damage. If an interconnect cable is used, disconnect the cable at both ends (sensor junction box and analyzer) and, using an ohmmeter, check its wires for continuity and internal shorts.

1.2 Replacing Fuse(s)

The analyzer is equipped with two board-mounted fuses (type T slow-blow; 5 mm x 20 mm size). Fuse values are shown next to the fuses (Figure 2-8). The fuses protect the 115 and 230 volt line power circuits.

WARNING:

DISCONNECT LINE POWER TO AVOID THE POSSIBILITY OF ELECTRICAL SHOCK.

1. After disconnecting line power, open the analyzer door and locate the fuses (shown in Figure 2-8).
2. Remove the blown fuse and replace it with a GLI fuse or an equivalent. Refer to PART FIVE -- Spare Parts -- for GLI fuse kit part number.
3. Reconnect line power and close the analyzer door.

1.3 Replacing Relays

The analyzer relays are soldered into a complex, multi-layered circuit board. To avoid the possibility of damaging this board while attempting to replace a relay:

- Simply return the complete analyzer to the GLI Customer Service Dept. or your local factory-authorized service organization for relay replacement.

-- or --

- Replace the complete scaling board assembly containing the relays. Refer to PART FIVE -- Spare Parts -- for the GLI scaling board assembly part number.

SECTION 2

PRESERVING MEASUREMENT ACCURACY

2.1 Keeping Sensor Clean

To maintain measurement accuracy, periodically clean and service the sensor. Operating experience will help you determine when to do this (weekly or monthly). Use the recommended procedure described in PART FOUR, Section 3.

2.2 Keeping Analyzer Calibrated

Depending on the circumstances of the application, system calibration should be performed periodically to maintain measurement accuracy.



Maintenance Tip! Upon startup, frequently check the system until operating experience can determine the optimum time between calibrations that provides acceptable measurement results.

2.3 Avoiding Electrical Interference

Recommendation: Do not run the sensor cable (and interconnect cable, if used) in the same conduit with AC or DC power wiring.



Maintenance Tip! Excess cable should not be coiled near motors or other equipment that may generate electrical or magnetic fields. Cut cables to proper length during installation to avoid unnecessary inductive pickup (“electrical noise” may interfere with sensor signal).

SECTION 3

SERVICING SENSOR

3.1 When to Service Sensor

Membrane wear and chemical reactions require a specific maintenance procedure to be performed periodically. The time period between maintenance can vary considerably with each application and its specific conditions. Operating experience should make the intervals apparent.

It is time to service the sensor when you experience:

- Difficulties with calibration
- A reading outside the 70-130% acceptable range during a SENSOR AIR TEST (PART THREE, Section 6.2)
- Noisy or drifting signals under known constant ozone concentration conditions

3.2 Removing Sensor from Sample Line

When removing the sensor from the sample line, make sure that no hazard will be created by the absence of the sensor.

1. Disconnect the sensor from the analyzer.
2. Remove the sensor from the sample line.
3. Place the sensor upright into the optional sensor servicing stand (or secure the sensor in an upright position).

3.3 Preparing Sensor for Cleaning

1. Refer to Figure 4-1 and carefully unscrew the protection cap using the metal tool supplied with the optional Model 5920-2 recharge kit. Take care not to lose any pieces including washers inside the protection cap.



FIGURE 4-1 Removing Sensor Protection Cap

Please note the arrangement order of the membrane assembly components shown in the Figure 4-2 exploded view.

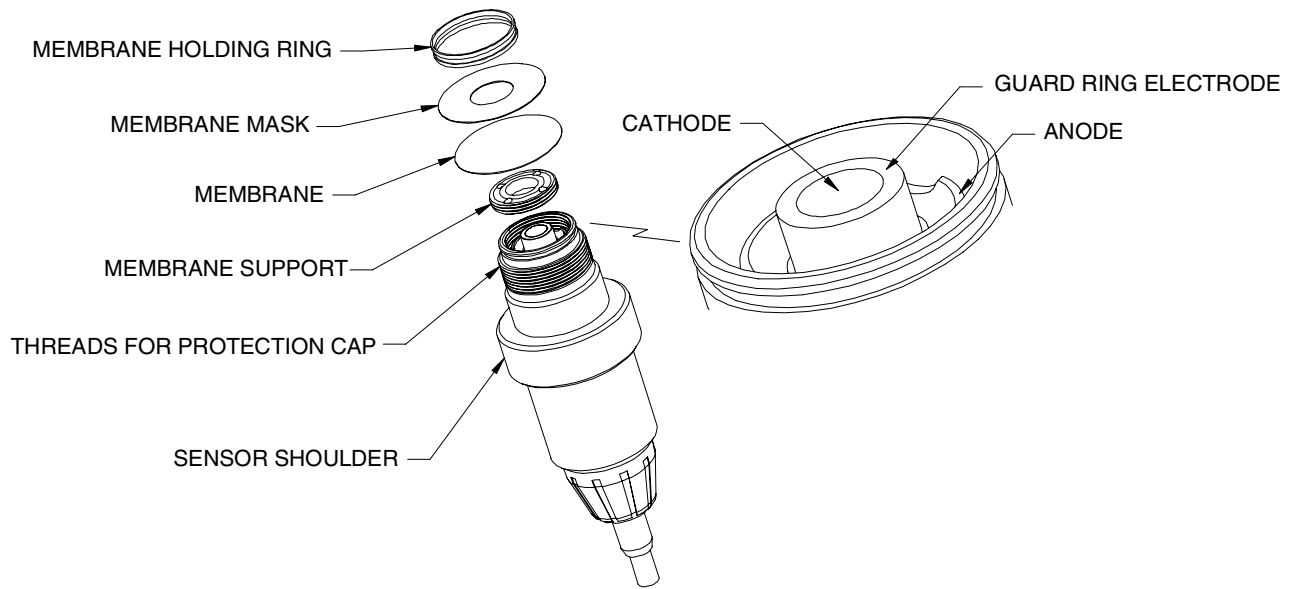

FIGURE 4-2 Sensor Membrane Assembly Components -- Exploded View

2. Pry off the membrane holding ring (Figure 4-3) using the special tool in optional recharge kit or your fingers.

CAUTION:

AVOID CONTACTING THE ELECTROLYTE IN THE SENSOR. IT CAN IRRITATE YOUR SKIN AND PERMANENTLY STAIN CLOTHING. THEREFORE, THOROUGHLY RINSE YOUR HANDS WITH PLENTY OF WATER DURING THIS PROCEDURE.

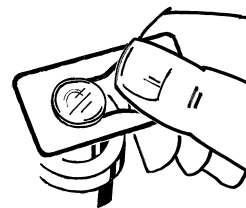

FIGURE 4-3 Removing Membrane Holding Ring

3. Discard the membrane and mask, but keep the holding ring and remove any residual electrolyte. Empty the electrolyte reservoir and rinse it with water.
4. Remove the membrane support using the membrane support tool (Figure 4-4). Insert both tool prongs into the two holes in the membrane support, and turn counterclockwise (left) to remove the support.

CAUTION:

EACH MEMBRANE SUPPORT IS INDIVIDUALLY MACHINED TO MATCH ITS SENSOR. THEREFORE, WHEN SERVICING MORE THAN ONE SENSOR AT A TIME, IT IS VERY IMPORTANT TO KEEP THE APPROPRIATE MEMBRANE SUPPORT WITH ITS RESPECTIVE SENSOR.

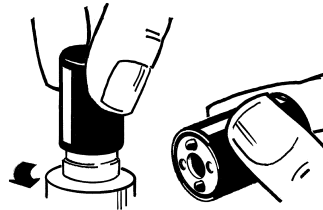

FIGURE 4-4 Removing Membrane Support

5. Rinse the membrane support with water. If discolored, the support can be cleaned with concentrated nitric acid (HNO_3), approximately 70% by weight but no stronger, for about 30 seconds. Thereafter, thoroughly rinse it with water. The discoloration does not affect sensor performance, but cleaning the support permits better viewing of the sensor.

WARNING:

NITRIC ACID IS DANGEROUS! ALWAYS USE PROTECTIVE GLOVES AND GOGGLES. SHOULD NITRIC ACID CONTACT YOUR SKIN, IMMEDIATELY AND THOROUGHLY WASH THE AREA WITH WATER.

3.4 Chemical Cleaning

Depending on the appearance of the sensor electrodes, try either the ammonium hydroxide or nitric acid cleaning procedure. If the electrodes appear:

- Fairly clean and bright, try ammonium hydroxide cleaning
- Very dirty or discolored, use the nitric acid cleaning

CAUTION:

IF EITHER CLEANING PROCEDURE IS NOT CLOSELY FOLLOWED, THERE IS A RISK OF SHORTENING THE USEFUL OPERATING LIFE OF THE SENSOR.

Ammonium Hydroxide Cleaning

1. Fill the sensor electrolyte reservoir with a solution of 25% by weight ammonium hydroxide (NH_4OH) in water and leave it soak for 10 minutes. Then rinse the reservoir with water for at least one minute.
2. Inspect the sensor head. The anode (counter electrode) should be uniformly silver-white in color. If the anode is clean, rinse the electrolyte reservoir again with water for a full minute. If the sensor head is still discolored, repeat step 1.

If three consecutive ammonium hydroxide cleanings do not produce the desired result, clean with nitric acid.

Nitric Acid Cleaning

1. Thoroughly rinse out the sensor head with water.
2. Place just enough concentrated nitric acid (HNO_3), up to 70% by weight but no stronger, in the sensor electrolyte reservoir to cover only the anode -- not the center gold cathode (Figure 4-5).

WARNING:

NITRIC ACID IS DANGEROUS! ALWAYS USE PROTECTIVE GLOVES AND GOGGLES. SHOULD NITRIC ACID CONTACT YOUR SKIN, IMMEDIATELY AND THOROUGHLY WASH THE AREA WITH WATER.



FIGURE 4-5 Cleaning Anode with Nitric Acid

3. Leave the acid in the reservoir for **no longer than 5 seconds**. Then empty out the acid, and thoroughly rinse the reservoir with water.

If the anode is still not completely clean, alternately between nitric acid and ammonium hydroxide cleanings.

3.5 Polishing Sensor Face

1. After ammonium hydroxide and/or nitric acid cleaning, use the metal membrane support tool to screw on the membrane support until it is “finger tight.” (The sensor has a safety feature to prevent stripping the plastic threads on the membrane support should it be over tightened.)



NOTE: The membrane support has a grooved smooth side and a side that is raised in the center. Make sure the grooved smooth side faces out as shown in Figure 4-6 when installed.

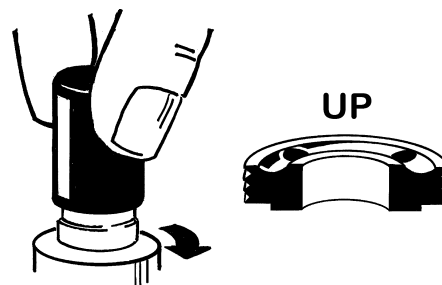

FIGURE 4-6 Replacing Membrane Support

2. Refer to Figure 4-7 and shake a small amount of polishing powder onto the cloth, adding enough clean water to make a loose, watery mixture.



FIGURE 4-7
Mixing Polishing Powder with Water on Polishing Cloth

3. Holding the sensor vertically as shown in Figure 4-8, use a circular motion to polish the sensor face for at least 30 seconds until the gold cathode is clean and shiny. (This step may need to be repeated several times.) Make sure to avoid skin contact with the polishing cloth, which must be kept free of dust and grease.

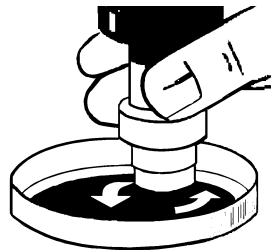

FIGURE 4-8
Polishing Sensor Face with Circular Motion

4. Remove the membrane support using the membrane support tool (Figure 4-4). Insert both tool prongs into the two holes in the membrane support, and turn counterclockwise (left) to remove the support.

CAUTION:

EACH MEMBRANE SUPPORT IS INDIVIDUALLY MACHINED TO MATCH ITS SENSOR. THEREFORE, WHEN SERVICING MORE THAN ONE SENSOR AT A TIME, IT IS VERY IMPORTANT TO KEEP THE APPROPRIATE MEMBRANE SUPPORT WITH ITS RESPECTIVE SENSOR.

5. Thoroughly rinse the membrane support and the sensor with water to remove all traces of polishing powder.
6. Inspect the groove between the gold cathode and the guard ring electrode for polishing powder residue. Rinse away any residue with a strong jet of water as shown in Figure 4-9.



FIGURE 4-9
Cleaning Groove Between Cathode and Guard Ring Electrode

3.6 Final Electrode Cleaning

After the sensor has been thoroughly cleaned using ammonium hydroxide and/or nitric acid, and the sensor face has been polished, do the following:

1. With the sensor upright, put a few drops of water in the electrolyte reservoir -- just enough to cover the anode only -- not the center gold cathode. **The gold cathode must be completely dry.**
2. Place a few drops of nitric acid onto the center gold cathode -- just enough to cover only the cathode and its guard ring (Figure 4-10). **Do not get any nitric acid on the anode.** Wait about 15 seconds and then rinse the gold cathode with water.

WARNING:

NITRIC ACID IS DANGEROUS! ALWAYS USE PROTECTIVE GLOVES AND GOGGLES. SHOULD NITRIC ACID CONTACT YOUR SKIN, IMMEDIATELY AND THOROUGHLY WASH THE AREA WITH WATER.

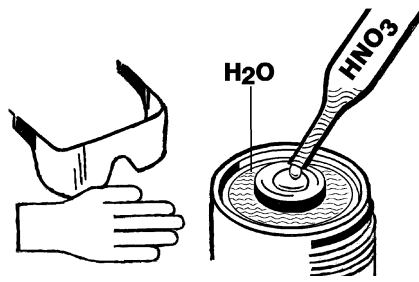

FIGURE 4-10
Cleaning Gold Cathode with Nitric Acid

3.7 Replacing Membrane

1. Use the metal membrane support tool to screw on the membrane support until it is “finger tight.” Make sure the grooved smooth side faces out as shown in Figure 4-6 when installed.
2. Fill the sensor head with electrolyte through the membrane support using the syringe from the optional Model 5920-2 recharge kit.



NOTE: For easier electrolyte filling, slightly tilt the sensor and fill the head from the lowest of the four holes as shown in Figure 4-11.

Fill slowly to force the air out through the top hole. Continue filling, returning the sensor to vertical, until a slight overflow of electrolyte adheres to the surface of the sensor face (Figure 4-11).

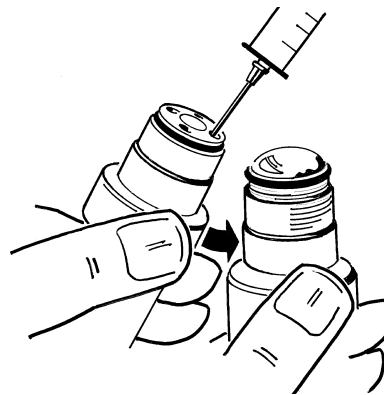

FIGURE 4-11
Filling Sensor with Electrolyte

3. To install a new membrane, use the black plastic membrane mounting tool included in the optional Model 5920-2 recharge kit. The tool consists of a plunger and a hollow cylindrical guide.

Place the cylindrical guide over the sensor head, around the sensor face so that it rests on the sensor shoulder as shown in Figure 4-12.



FIGURE 4-12
Placing Guide on Sensor

4. Using the cylindrical guide, first place a new membrane, and then mask on the sensor face, checking that they lie flat and are centered (Figure 4-13).



NOTE: To avoid air bubbles, place the membrane at an angle into the guide. Also, make sure to place the sensor mask directly on top of the membrane in the guide.



FIGURE 4-13
Placing Membrane on Sensor Face

- Slide the membrane holding ring onto the beveled edge of the mounting tool plunger as shown in Figure 4-14.

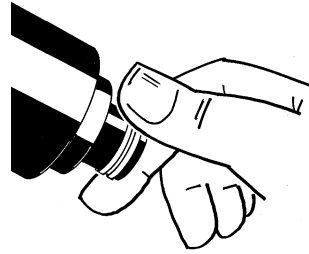

*FIGURE 4-14
Placing Membrane Holding Ring on Plunger*

- Insert the plunger, with holding ring, into the open hole of the guide as shown in Figure 4-15.

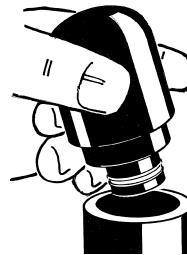

*FIGURE 4-15
Inserting Plunger into Guide*

- Push the plunger down to the stop as shown in Figure 4-16 to complete membrane mounting. Remove both parts of the membrane mounting tool.

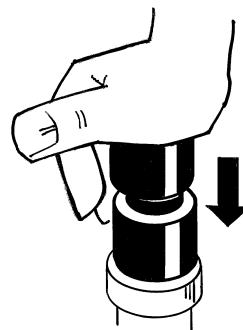

*FIGURE 4-16
Completing Membrane Mounting*

8. Inspect the membrane holding ring to be sure it is properly seated and completely pushed in. Also, make sure the membrane is smooth. If not, you may be able to push the holding ring down with your fingers to smooth the membrane. If this does not work, replace the membrane by repeating the previous steps.

CAUTION:

DO NOT TOUCH THE MEMBRANE WITH YOUR FINGERS. OILS FROM YOUR FINGERS RENDER THE MEMBRANE INOPERABLE.

9. Inspect the O-ring that forms a seal between the membrane holding ring and sensor. Replace this O-ring if the holding ring easily turns.
10. Check that no air bubbles exist under the membrane surface. If there are bubbles, the membrane must be replaced.
11. Wash any excess electrolyte off the sensor and wipe the sensor dry.

3.8 Placing Sensor Back into Operation

After installing a new membrane, follow these steps to place the sensor back into operation.

1. Make sure that the components in the protection cap include:
 - Two Tefzel washers
 - Stainless steel grill
 - Dacron mesh
 - Silicone washer

Check to make sure that these components are clean, **completely dry**, and in the correct order before installing the protection cap. See Figure 5-1 for details.

2. Finger-tighten the protection cap onto the sensor.
3. Using the metal tool in the optional Model 5920-2 re-charge kit, secure the protection cap with an extra 1/8 to 1/4 turn as shown in Figure 4-17.

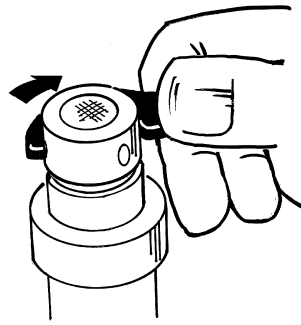

FIGURE 4-17
Replacing Protection Cap

4. After allowing the membrane to relax for at least 30 minutes, calibrate the sensor as described in PART THREE, Section 5.2.
5. After calibrating the sensor, install it into the sample line and start the sample flow. The system should be ready to measure.

SECTION 4

STORING SENSOR

During a short shut-down period, such as overnight or weekends, the sensor can be left in the sample line.

For slightly longer inactive periods, remove the sensor from the sample line. Place a drop or two of water into the sensor shipping/storage cap, and secure the cap onto the sensor to prevent the membrane from drying out.

If you expect to not use the sensor for more than a few months, store it “dry.” This means:

1. Clean the sensor as described in PART FOUR, Section 3.
2. Do not put any electrolyte into the sensor reservoir.
3. Secure the shipping/storage cap (without any drops of water in it) onto the sensor.

SECTION 5

TROUBLESHOOTING

5.1 Ground Loops

The analyzer may be affected by a “ground loop” problem (two or more electrically grounded points at different potentials).

Symptoms Indicating a Possible Ground Loop

- Analyzer reading is offset from the actual value by a consistent amount, or
- Analyzer reading is frozen on one value, or
- Analyzer reading is “off scale” (upscale or downscale).

Although the source of a ground loop is difficult to determine, there are several common causes.

Common Causes of a Ground Loop

- Components, such as recorders or computers, are connected to non-isolated analog outputs.
- Not using shielded cabling or failure to properly connect all cable shields.
- Moisture or corrosion in a junction box.

Determining if Ground Loop Exists

The following simple test can help to determine if there is a ground loop:

1. With the MEASURE screen displayed, put the sensor in a non-conductive container (plastic or glass) filled with a known value ozone reference solution. Note the analyzer reading for this solution.
2. Connect one end of a wire to a known earth ground, such as the analyzer grounding strip (at bottom of case) or a metal water pipe. Place the other end of this wire into the reference solution next to the sensor.
3. Note the analyzer reading now and compare it with the reading taken in step 1. If the reading changed, a ground loop exists.

Finding Source of Ground Loop

Sometimes the source of a ground loop is easy to find, but it usually takes an organized approach to isolate the problem.



Troubleshooting Tip! Use a systematic troubleshooting method. If possible, start by grounding all shields and electrical grounds at one stable point. One at a time, turn off all pumps, motors and switches in electrical contact with the process. Each time you do this, check if the ground loop still exists. Since the process media being measured is electrically conductive, the source of the ground loop may not be readily apparent.

5.2 Isolating Measuring System Problem

Checking Electrical Connections

When experiencing problems, try to determine the primary measurement system component causing the problem (sensor, analyzer, or sensor cable).

1. Verify that line power exists at the appropriate analyzer TB3 terminals.
2. Check all analyzer cable connections to ensure they are properly connected.

Verifying Sensor Operation

The Model 5920Z0 sensor is fully tested before shipment. Provided it has been handled properly and is correctly installed, it should be trouble-free.

The following list shows possible troubles caused by poor handling or identifiable installation conditions. If you cannot find a solution here, contact the GLI Customer Service Dept.

Problem	Probable Cause	Possible Solution
Shorter-than-expected sensor operation (in relatively high ozone concentration)	High ozone concentrations require more work from this electrochemical sensor	Shut off analyzer when not needed, and service the sensor more frequently
Unexpected/incorrect ozone readings	Sample air leak	Set flow rate to 100 ml/min; wait until stable. Slowly increase rate to 200 ml/min. If a significant ozone decrease is displayed, a sample air leak is likely.
	High residual current	Place sensor in de-aerated sample; wait for low reading; check concentration against low measurement limit. If concentration is significantly higher than low limit, try servicing sensor (PART FOUR, Section 3).

SECTION 6

ANALYZER REPAIR/RETURN

6.1 Customer Assistance

If you need spare parts, assistance in troubleshooting, or repair service, please contact your local GLI representative, or the GLI Customer Service Department at:

GLI International, Inc.	Phone: [800] 543-8907
9020 West Dean Road	Fax: [414] 355-8346
Milwaukee, WI 53224	E-mail: info@gliint.com

— GLI SERVICE DEPARTMENT HOURS —

	Eastern Std. Time	Central Std. Time	Mountain Std. Time	Pacific Std. Time
Monday through Thursday	8:30 a.m. to 5:30 p.m.	7:30 a.m. to 4:30 p.m.	6:30 a.m. to 3:30 p.m.	5:30 a.m. to 2:30 p.m.
Friday	8:30 a.m. to 4:00 p.m.	7:30 a.m. to 3:00 p.m.	6:30 a.m. to 2:00 p.m.	5:30 a.m. to 1:00 p.m.

6.2 Repair/Return Policy

All analyzers/sensors returned for repair or replacement must be freight prepaid and include the following information:

1. A clearly written description of the malfunction.
2. Name of person to contact and the phone number where they can be reached.
3. Proper return address for shipping analyzer(s) back. Include preferred shipping method (UPS, Federal Express, etc.) if applicable.
4. A purchase order if analyzer/sensor(s) is out of warranty to cover costs of repair.



NOTE: *If the analyzer/sensor is damaged during return shipment because of inadequate packaging, the customer is responsible for any resulting repair costs. (Recommendation: Use the original shipping carton or an equivalent.)*

Also, GLI will not accept analyzers returned for repair or replacement unless they are thoroughly cleaned and all process material is removed.

PART FIVE - SPARE PARTS AND ACCESSORIES

	Description	Part Number
O53 Ozone Analyzer	Complete Door Assembly:	
	Without HART option	O53A2010-003
	With HART option	O53A2010-004
	Power Supply/Scaling Board Assembly.....	O53A2020-001
	Ribbon Interconnect Cable	1000A3355-001
	Fuse Kit..... (one 80 mA fuse and one 100 mA fuse per package)	1000G3315-101
	Mounting Hardware Kit	1000G3228-101
5920Z0 Ozone Sensor	New Ozone Sensor.....	5920Z0
	Factory-refurbished Replacement Ozone Sensor..... (includes cleaned electrodes, new membrane, and fresh electrolyte)	5920-1
	<p>NOTE: After receiving the refurbished sensor, return your old sensor with its shipping/storage cap for a trade-in credit. If not, you will be charged the full price of a new sensor for the refurbished sensor.</p>	
	Ozone Sensor Recharge Kit (for reconditioning sensor).....	5920-2
	Kit includes:	25 membranes 25 masks 250 ml of electrolyte Polishing powder Membrane holding ring Special sensor tools
	Membrane/Mask Kit.....	5920-6
	(same as 5920-2 recharge kit listed above except without membrane holding ring and special sensor tools)	
Model 5920Z0 Ozone Sensor component spare parts are shown in Figure 5-1 on the next page.		
	Sensor Servicing Stand	5920-5
	(conveniently holds sensor for routine servicing)	
	Sensor Union Mounting Hardware: Stainless Steel	5920-3
	PVC	5920-4
	(hardware includes special 2-inch union tee, lock ring, tee plug, and Viton O-ring seals)	
	Sensor Interconnect Cable.....	1W1100
	(same as sensor cable; supplied non-terminated; specify length in whole feet)	
	NEMA 4X Surface Mount Junction Box	76A4000-003
	(with terminal strip, gasketed cover, and cord grips)	

Figure 5-1 below shows item number call-outs for the Model 5920Z0 Ozone Sensor component spare parts.

Item No.	Description	Part Number
1	EPDM O-ring	29039.0
2	Membrane	2956A
3	Saran Mask	29026A
4	Membrane Holding Ring	29228
5	Silicone Washer.....	28003
6	Dacron Mesh	29049
7	Stainless Steel Grill.....	29060
8	Tefzel Washers (two)	28002
9	Stainless Steel Protection Cap	29106

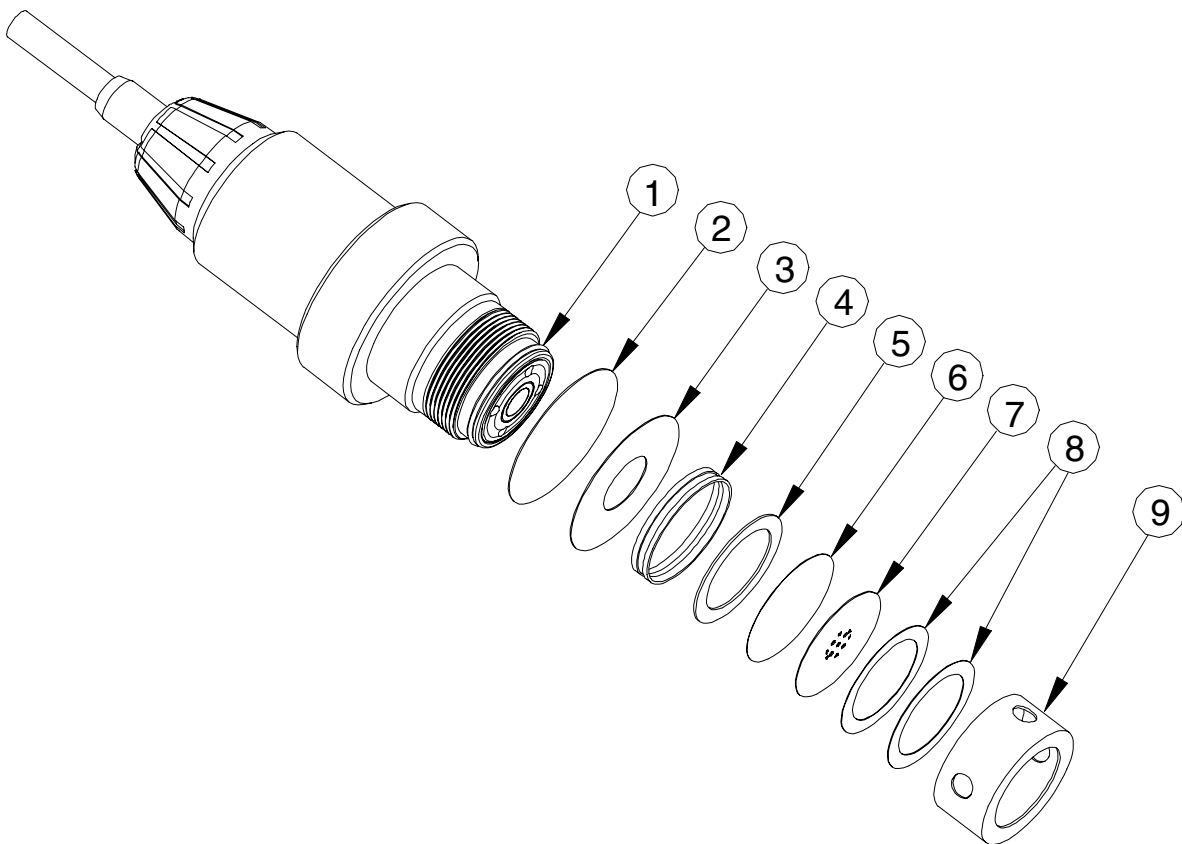

Figure 5-1 Sensor Component Spare Parts -- Exploded View