

PAH500 PAH Oil-in-Water Continuous Online Monitoring Sensor

Applications

- Maritime Water



Proven. Trusted. Reliable. The solution for exhaust gas cleaning systems.

Reliability

With hundreds of successful installations on inlet and outlet scrubber applications, you can have confidence in accurate readings, maximum uptime, premium service and support from a global water quality company. The PAH500 is the online oil-in-water sensor that delivers high sensitivity with low cost of ownership.

Hach's 85 years of water analysis leadership, experience, and innovation ensure that you're getting the best instrument and peace of mind to go along with it.

Certifications

We understand how important your business and your equipment are to you, that's why we take pride in receiving certifications from the following organisations:

Maritime Type Approvals: DNV-GL, ABS, ClassNK, Japanese Government, and Korean Register**

Marine Environmental Protection Committee: MEPC.259(68) from DNV-GL

Certification demonstrates Hach's commitment to continual improvement and sustainable business performance.



** Certifications may be pending final reviews & certifications with certain Maritime Societies.

Minimal Maintenance

With no tubes, pumps, or valves that can foul, maintenance is limited to occasional cleaning of the quartz tube and service once every other year to stay in compliance with IMO regulations (annual for USCG regulations). After all, why spend time on maintenance when you don't have to?

Built for Maritime

The PAH500 was purpose built for harsh maritime applications. It can detect and measure polycyclic aromatic hydrocarbons (PAHs) from 0 - 900 ppb ($\mu\text{g/L}$). Titanium housing and quartz measurement tube help to eliminate corrosion in exhaust gas cleaning system (EGCS) applications. The sensor is nitrogen purged from the factory, ensuring reliable operation in humid environments. The light source, filtering, and calibration for Phenanthrene in exhaust gas scrubbers mean that this sensor is designed specifically for your application.

Hach offers a variety of products to support your EGCS application and comply with IMO regulations including:

- Ultraturb sc (Turbidity)
- pHD (pH)
- Series 3700 (Conductivity)
- SC1000 (Controller)



Technical Data*

PAH500 Sensor

Measurement method	Ultraviolet (LED) 255 nm excitation; 370 nm detection
Measurement principle	UV Fluorescence
Parameter	PAH (polycyclic aromatic hydrocarbon)
Measuring range	0 - 900 µg/L PAH / PHE (phenanthrene equivalents)
Accuracy	± 5 µg/L for readings ≤ 100 µg/L ± 5% for readings > 100 µg/L
Turbidity compensation	Calculated, accurate for turbidity ≤ 150 NTU
Data storage	10 s - 15 min
Measuring interval	60 s
Operating temperature range	5 - 55 °C
Power requirements (Voltage)	12 VDC supplied by digital gateway
Power consumption	1 W
Housing material	Titanium
Dimensions	Sensor Body (Ø x L): 76.2 x 145.1 mm (3.0 x 5.71 in)
Weight	1 kg
Cable	Analog cable, 4-conductors + shield, drain wire, 24 AWG, 90 °C, 600 V _{RMS} , IEC 60332-1-2; UL94 VW-1, 1 - 3 m (standard: 1 m)
Certifications	EU CE Mark Maritime Type Approvals**: DNV-GL, ABS, Class NK, Japanese Government, Korean Register Marine Environment Protection Committee - MEPC.259(68)

A/D Gateway

Interface	Analog: 0 - 5 VDC (input from sensor), 12 VDC (output to sensor) Digital: Modbus, RS485 (output)
Dimensions	Gateway (Ø x L): 34 x 175 mm (1.4 x 7 in)
Weight	145 g
Cable	Cable between the sensor and digital gateway: 1 m (3.3 ft); flame rating IEC 60332-1-2; UL94 VW-1
Connector	M12 Male/Female
Flame retardancy	UL94 V-0 (GW housing, plastics) IEC 60332-1-2, UL VW-1 (digital cables)
Enclosure waterproof rating	IP67
Power requirements (Voltage)	12 VDC supplied by SC1000 Controller, 1.8 W

*Subject to change without notice.

**Certifications may be pending final reviews & certifications with certain Maritime Societies.

Principle of Operation

The measuring principle is based on the fluorescent properties of PAHs. After excitation caused by a UV light source, PAHs emit light with longer wavelengths after a short time delay. The intensity of this light is measured and is proportional to the concentration of the PAHs. This measuring principle is considerably more sensitive than absorption and scattered light measurement. It is possible to detect even the slightest trace of PAH contamination in water. PAHs are integral parts of most mineral oil products and are a very specific indicator of oil contamination in water bodies and process water.

Dimensions

[in millimeters / inches]

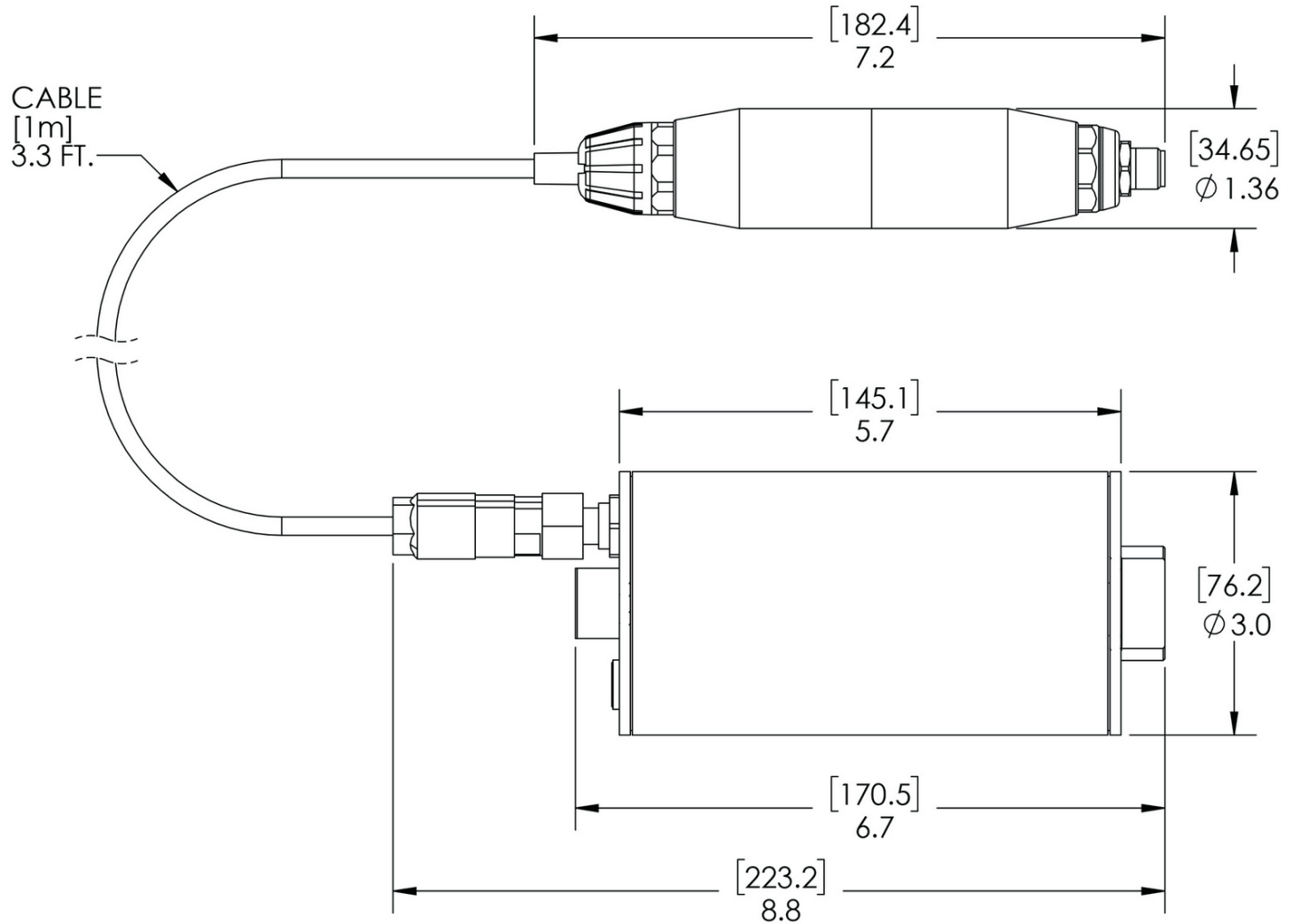

Order Information

PAH Sensors

LXV541.99.1001H	PAH500 Digital PAH Sensor, 1.0 m Cable, Bracket
LXV541.99.2001H	PAH500 Digital PAH Sensor, 7.7 m Cable, Bracket
LXV541.99.3001H	PAH500 Digital PAH Sensor, 15 m Cable, Bracket
LXV541.99.4001H	PAH500 Digital PAH Sensor, 30 m Cable, Bracket

Accessories

6122400	Digital Extension Cable, 1 m (3.3 ft.)
5796000	Digital Extension Cable, 7.7 m (25 ft.)
5796100	Digital Extension Cable, 15 m (50 ft.)
5796200	Digital Extension Cable, 30 m (100 ft.)
6166300	Drain Valve
6845000	¼" NPT Plug
LXZ541.99.0001H	Mounting Brackets

SC1000 Controller

Probe Modules:

LXV400.99.00121	SC1000 Probe Module, 4 Sensors, 4x 4-20 mA Out, 100-240 VAC
LXV400.99.20121	SC1000 Probe Module, 4 Sensors, 4x 4-20mA Out, 100-240 VAC, EU power cord

Display Module:

LXV402.99.00201	SC1000 Display Module w/o GSM
------------------------	-------------------------------

Reagents and Consumables

LZC541	PAH500 Sensor Calibration Kit
2563899	Phenanthrene Standard, 25 ppb
2563901	Phenanthrene Standard, 50 ppb
2088000	Alconox Detergent
2088153	Liqui-Nox Detergent
1227642	Isopropyl Alcohol
244932	Sulfuric Acid, 5.25 N
9774000	Cleaning Swab, pk/50
2749320	Disposable Pipettes, pk/20

First in Support and Service

With Hach Service, you have a global partner who understands your maritime needs and cares about delivering timely, high-quality service you can trust. Our Service Team brings unique expertise to help you maximise instrument uptime, ensure data integrity, maintain operational stability, and reduce compliance risk.