

Laser alignment tool 800012402 for Flo-Dar sensor

Safety Information

The manufacturer is not responsible for any damages due to misapplication or misuse of this product including, without limitation, direct, incidental and consequential damages, and disclaims such damages to the full extent permitted under applicable law. The user is solely responsible to identify critical application risks and install appropriate mechanisms to protect processes during a possible equipment malfunction.

Please read this entire manual before unpacking, setting up or operating this equipment. Pay attention to all danger and caution statements. Failure to do so could result in serious injury to the operator or damage to the equipment.

Make sure that the protection provided by this equipment is not impaired. Do not use or install this equipment in any manner other than that specified in this manual.

Use of hazard Information

DANGER

Indicates a potentially or imminently hazardous situation which, if not avoided, will result in death or serious injury.

Note: Information that supplements points in the main text.

Overview

DANGER

Explosion hazard. The laser alignment tool is not intrinsically safe. Do not use in a hazardous location.

The laser alignment tool is used to accurately position the supporting frame for the Flo-Dar sensor. The tool simulates the position and direction of the Flo-Dar velocity and level sensors with a laser pointer. Refer to [Figure 1](#) for dimensions and features.

Depending on the sensor frame used, it is important to position the laser alignment tool with the back edge of the slots on either side fully against the vertical brackets of the mounting frame. Refer to [Figure 2](#) for the correct position.

The installation objectives for the sensor and sensor frame are described in the Flo-Dar Sensor User Manual.

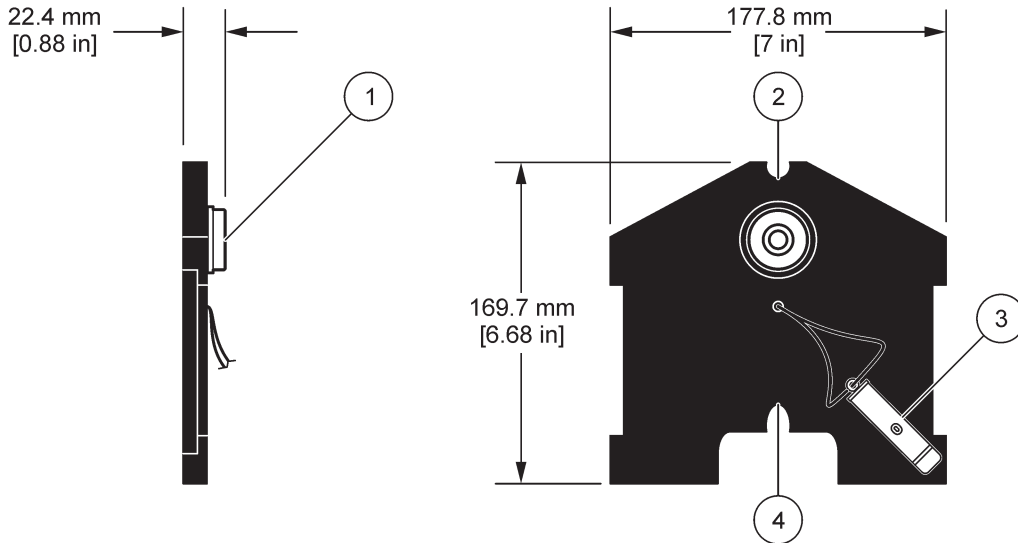

Figure 1 Laser alignment tool dimensions and features

1	Bubble level	3	Laser pointer
2	Level position slot for laser pointer	4	Velocity position slot for laser pointer

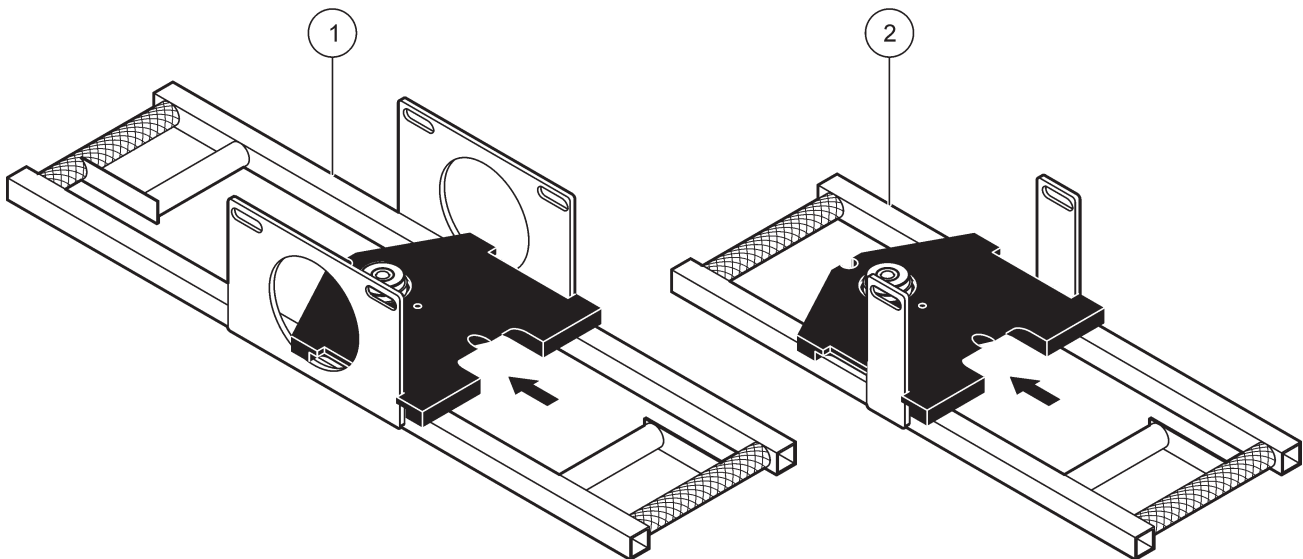

Figure 2 Laser alignment tool on frame

1	Frame for Flo-Dar sensor with extended range depth sensor
2	Standard frame

Velocity sensor frame adjustment

1. Snap the laser pointer in the velocity position (see [Figure 1](#)) of the alignment tool. Make sure the laser pointer is fully seated in the slot.
2. Position the alignment tool on the frame as shown in [Figure 2](#).
3. With the frame clamp bolts loosened enough to allow adjustment but tight enough to hold in position, level the frame with the bubble level.

Note: If the pipe is not level and has a slope of 2 degrees or more, align the sensor to be parallel with the surface of the water.

4. Turn the laser pointer on. Adjust the frame so that the laser beam just passes below the crown of the pipe as shown in [Figure 3](#).

Note: A sheet of paper can be applied across the upper face of the pipe as a reflective surface. This is useful to show the elevation of the laser beam below the pipe crown.

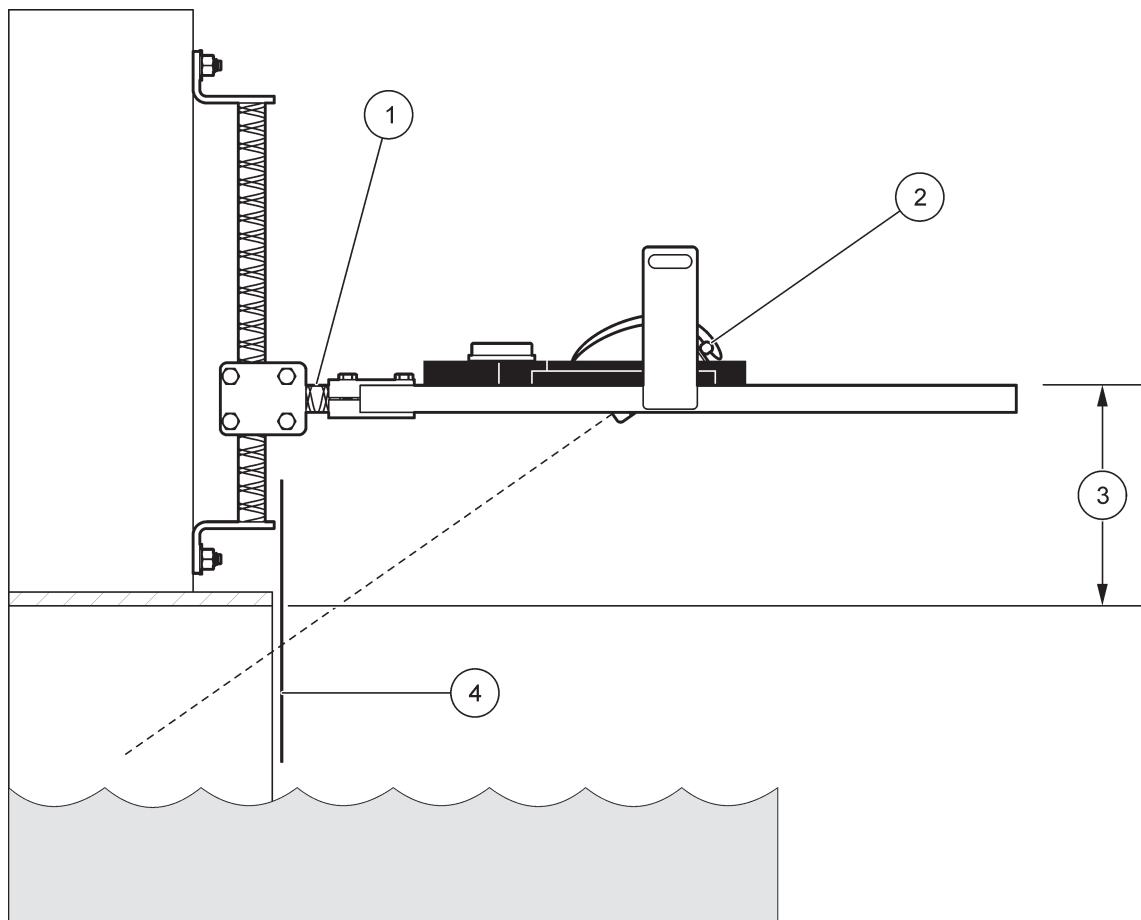

Figure 3 Velocity sensor adjustments

1	Replace 2- $\frac{1}{4}$ in. spacer with cut lengths of 12 in. spacer as necessary	3	For Flo-Dar sensors without the SVS option, adjust this dimension as necessary
2	Laser pointer in the velocity sensor position	4	Paper

Level sensor frame adjustment

Note: The purpose of this adjustment is to center the level sensor over the flow. This adjustment also affects the velocity position.

1. Snap the laser pointer in the level position (see [Figure 1](#)) of the alignment tool. Make sure the laser pointer is fully seated in the slot.
2. Position the alignment tool on the frame as shown in [Figure 2](#).
3. Turn the laser pointer on. Adjust the frame so that the laser beam is in the center of the flow (pipe). Use a tape measure to find the center. Side to side movement and rotation along the long axis of the frame will center the beam as shown in [Figure 4](#).
4. Examine the velocity sensor position again and adjust if necessary.
5. When the bubble level is centered and the velocity and level sensor adjustments are complete, tighten all bolts.

Note: If the pipe is not level and has a slope of 2 degrees or more, align the sensor to be parallel with the surface of the water.

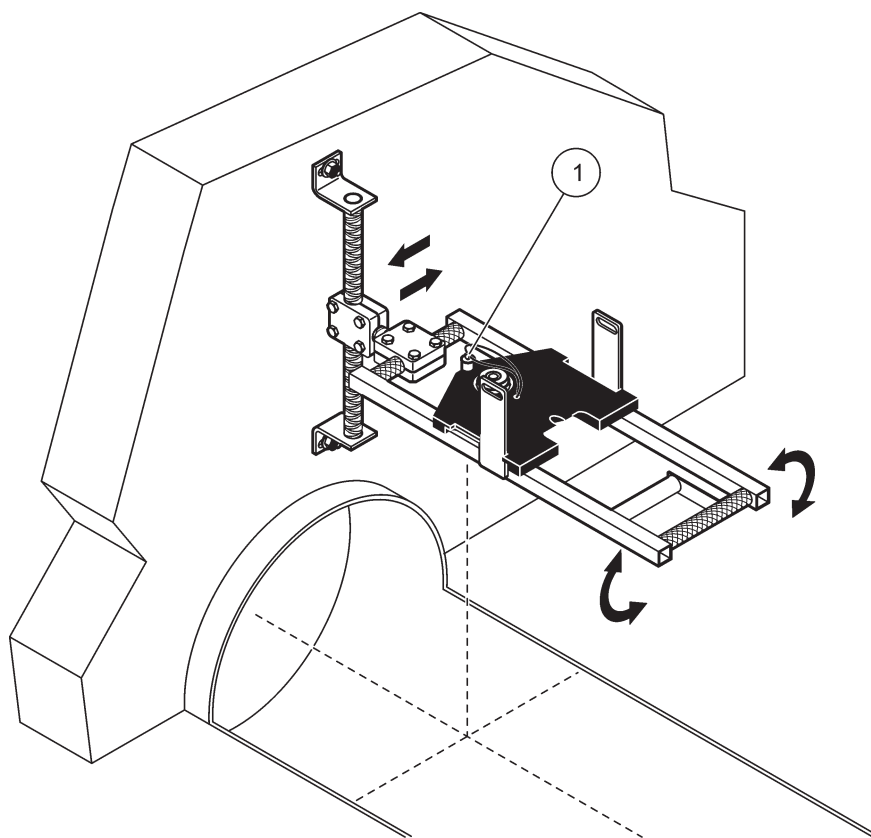

Figure 4 Level sensor adjustments

1 Laser pointer in the level sensor position

McCrometer, Inc.

3255 West Stetson Avenue

Hemet, CA 92545 USA

Tel: 951-652-6811

800-220-2279

Fax: 951-652-3078

hachflowtechsupport@mccrometer.com

www.mccrometer.com



USA Copyright © McCrometer, Inc. All printed material should not be changed or altered without permission of McCrometer. Any published pricing, technical data, and instructions are subject to change without notice. Contact your McCrometer representative for current pricing, technical data, and instructions.