



DOC024.52.93019

# **ORBISPHERE Model C1100 Ozone Sensor**

User Manual

04/2026, Edition 12



<b>Section 1 General Information</b> .....	3
1.1 Safety information .....	3
1.1.1 Use of hazard information .....	3
1.1.2 Service and repairs .....	3
1.1.3 Precautionary labels.....	3
<b>Section 2 Technical Specifications</b> .....	5
2.1 Sensor specifications .....	5
2.2 Sensor configuration .....	5
2.3 Sensor membrane specifications .....	6
2.3.1 Ozone sensors .....	6
<b>Section 3 Introduction</b> .....	7
3.1 What you have received .....	7
3.1.1 C110x electrochemical sensor .....	7
3.1.2 Protection caps .....	7
3.1.3 Sensor recharge kit .....	8
3.2 Sensor components .....	9
3.3 Basic principle of operation .....	9
<b>Section 4 Installation</b> .....	11
4.1 Sensor preparation .....	11
4.2 Sensor installation.....	16
4.2.1 Sensor positioning information.....	16
4.2.2 Sensor insertion .....	16
4.2.3 Sensor removal .....	17
4.3 Mounting accessories .....	17
4.3.1 Weld-on stainless steel socket.....	17
4.3.2 The 32003 insertion/extraction valve .....	18
4.3.3 The 33095 sensor housing.....	18
4.3.4 Tuchenhagen Varivent® in-line access unit.....	18
4.3.5 ORBISPHERE flow chambers .....	19
<b>Section 5 Calibration</b> .....	21
5.1 O <sub>3</sub> sensor calibration .....	21
5.2 In Air calibration procedure .....	21
<b>Section 6 Maintenance and Troubleshooting</b> .....	23
6.1 Maintenance .....	23
6.1.1 Electrochemical cleaning and regeneration center .....	23
6.1.2 Membrane replacement and sensor head cleaning .....	24
6.2 Troubleshooting .....	30
6.2.1 Ozone sensor.....	30
<b>Section 7 Accessories and Spare Parts</b> .....	31
7.1 Sensor spare parts.....	31
7.2 Recharge kits for C110x sensors.....	31
7.3 Flow chambers and installation devices .....	31
7.4 Certificates .....	32



# Section 1 General Information

---

In no event will the manufacturer be liable for direct, indirect, special, incidental or consequential damages resulting from any defect or omission in this manual. The manufacturer reserves the right to make changes in this manual and the products it describes at any time, without notice or obligation. Revised editions are found on the manufacturer's website.

## 1.1 Safety information

The manufacturer is not responsible for any damages due to misapplication or misuse of this product including, without limitation, direct, incidental and consequential damages, and disclaims such damages to the full extent permitted under applicable law. The user is solely responsible to identify critical application risks and install appropriate mechanisms to protect processes during a possible equipment malfunction.

Please read this entire manual before unpacking, setting up or operating this equipment. Pay attention to all danger and caution statements. Failure to do so could result in serious injury to the operator or damage to the equipment.

Make sure that the protection provided by this equipment is not impaired. Do not use or install this equipment in any manner other than that specified in this manual.

### 1.1.1 Use of hazard information

<b>⚠ DANGER</b>
Indicates a potentially or imminently hazardous situation which, if not avoided, will result in death or serious injury.

<b>⚠ WARNING</b>
Indicates a potentially or imminently hazardous situation which, if not avoided, could result in death or serious injury.

<b>⚠ CAUTION</b>
Indicates a potentially or imminently hazardous situation that may result in minor or moderate injury.

<b>NOTICE</b>
Indicates a situation which, if not avoided, may cause damage to the instrument. Information that requires special emphasis.

### 1.1.2 Service and repairs

None of the sensor's components can be repaired by the user. Only personnel from Hach or its approved representative(s) is (are) authorized to attempt repairs to the sensor and only components formally approved by the manufacturer should be used.

Any attempt at repairing the sensor in contravention of these principles could cause damage to the sensor and corporal injury to the person carrying out the repair. It renders the warranty null and void and could compromise the correct working of the sensor and the electrical integrity or the CE compliance of the sensor.





If you have any problems with installation, or using the sensor please contact the company that sold it to you. If this is not possible, or if the results of this approach are not satisfactory, please contact the Customer Service department of Hach.

### 1.1.3 Precautionary labels

Read all labels and tags attached to the instrument. Personal injury or damage to the instrument could occur if not observed.

## General Information

---

	<p>This is the safety alert symbol. Obey all safety messages that follow this symbol to avoid potential injury. If on the instrument, refer to the instruction manual for operation or safety information.</p>
	<p>This symbol, if noted on the product, indicates the need for protective eye wear.</p>
	<p>This symbol indicates the need for protective hand wear.</p>
	<p>Electrical equipment marked with this symbol may not be disposed of in European public disposal systems. In conformity with European local and national regulations, European electrical equipment users must now return old or end-of-life equipment to the manufacturer for disposal at no charge to the user.</p>
	<p>Products marked with this symbol indicates that the product contains toxic or hazardous substances or elements. The number inside the symbol indicates the environmental protection use period in years.</p>

## Section 2 Technical Specifications

The product has only the approvals listed and the registrations, certificates and declarations officially provided with the product. The usage of this product in an application for which it is not permitted is not approved by the manufacturer.

Specifications are subject to change without notice.

### 2.1 Sensor specifications

**Table 1 ORBISPHERE C110x oxygen sensors**

	Standard sensors	Low pressure sensors
Type	Electrochemical ozone sensor	
Dimensions (Ø × L)	39.5 × 86.2 mm (1.56 × 3.39 inch)	
Weight	300 g	
Mechanical pressure resistance	20 bar	4 bar
Other	Smart capability	
Certification	CE	

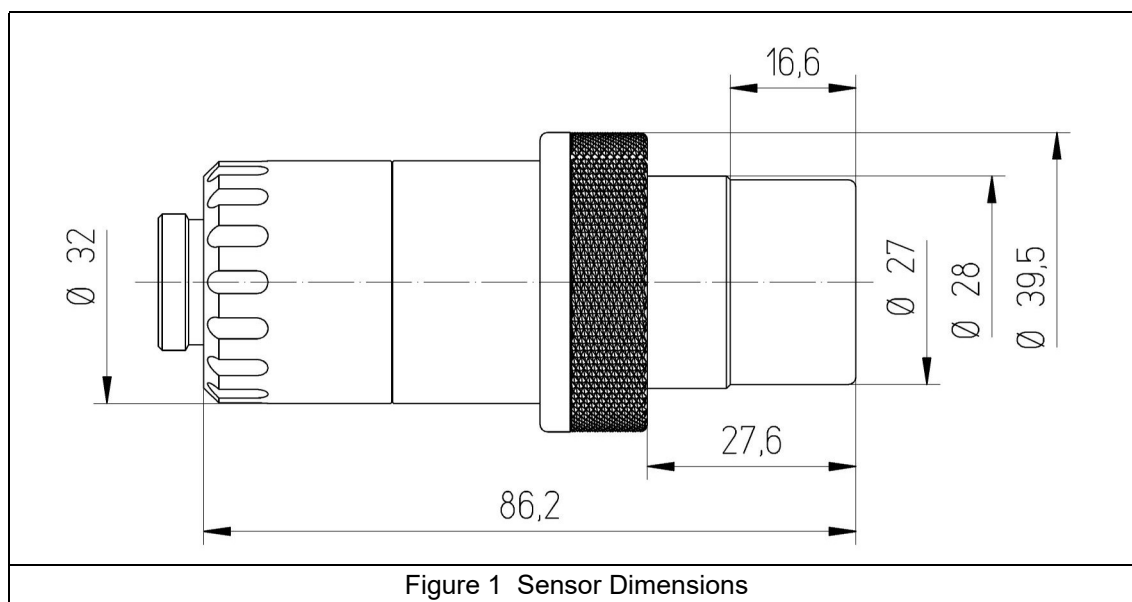

**Note:** Low pressure sensors can only be used with the corresponding low pressure, master instruments (510L or 410L).

### 2.2 Sensor configuration

The standard sensor configurations for Beverage, Pharmaceutical and Life Science applications are:

Sensor	Membrane Cartridge	Protection Cap
C1100-S00	2956A-CT	33051-ST
C1100-S0S	2956A-CT	33051-ST
C1100-T00	29552A-CT	33051-TT

**Note:** Sensors are delivered with one protection cap with grille as standard.

For low pressure location:

Sensor	Membrane cartridge	Protection cap
C1100-LP0	2957A-LP	33051-ST

**Note:** Low pressure sensors can only be used with the corresponding low pressure, master instruments (510L or 410L).

## 2.3 Sensor membrane specifications

### 2.3.1 Ozone sensors

**Table 2 Membrane specifications - Ozone sensors**

	2956A	29552A	2957A
Recommended applications	Trace measurement	High concentration (> 1 mg/l)	Trace measurement
Material	PFA	PTFE	PFA
Thickness [µm]	25	50	25
Calibration gas	Span gas or air		
Dissolved measurement range	0 ppb to 50 ppm	0 ppb to 200 ppm	0 ppb to 50 ppm
Accuracy	The greater value of ±1% of reading (± 5% for sensors calibrated in air) or ± 0.4 ppb, or ±1 Pa	The greater value of ±1% of reading (± 5% for sensors calibrated in air) or ± 20 ppb, or ± 4 Pa	The greater value of ±1% of reading (± 5% for sensors calibrated in air) or ± 0.4 ppb, or ±1 Pa
Expected current in air @ 1 bar 25°C [µA]	25.3	6.5	25.3
Temp. compensation range	– 5 to 45° C		
Temp. measuring range	– 5 to 100° C		
Response time <sup>1</sup>	25 sec.	6 min.	25 sec.
Recommended min. liquid flow rate <sup>2</sup> [mL/min]	350 <sup>3</sup>	100 <sup>3</sup>	350 <sup>3</sup>
Recommended min. linear flow rate <sup>2</sup> [cm/sec]	30	10	30
FDA Compliance	Yes	No	No

<sup>1</sup> Response time at 25°C for a 90% signal change

<sup>2</sup> Liquid flow through an ORBISPHERE 32001 flow chamber, with protection cap and no grille

<sup>3</sup> These flow rates take into account the decomposition of ozone in the tubing between the line and the flow chamber (theoretical flow rates in the absence of decomposition would be 10 times less)

## 3.1 What you have received

### 3.1.1 C110x electrochemical sensor

The sensor may be delivered separately or as part of an ORBISPHERE system, depending on the individual order.



Figure 2 C1100-S00 sensor with storage cap

The sensor is supplied with a screw-on plastic cap to protect the sensor head and for storage. Refer to [Figure 2](#). This is held in place with a plastic collar for the C1100-S00 and C1100-LP0 sensors, or a stainless steel collar for the C1100-T00 and C1100-S0S sensor.

A plastic screw-on base is also provided to protect the connection socket, and which also provides a suitable stand for the sensor during maintenance procedures, and when not in use.

### 3.1.2 Protection caps



Figure 3 Protection cap

One protection cap with grille (as illustrated in [Figure 3](#) above) will be delivered as standard with each sensor.

The C1100-S00, C1100-S0S and C1100-LP0 sensors are delivered with a stainless steel protection cap (part number 33051-ST) and the C1100-T00 sensor is delivered with a titanium protection cap (part number 33051-TT).

## 3.1.3 Sensor recharge kit

A recharge kit (as illustrated in [Figure 4](#) below) should have been ordered with the sensor as this will be required to initially make the sensor operational. It is also required for sensor cleaning and membrane replacement procedures.

**Note:** The recharge kit for **ozone** has a **green** sticker on the front of the box.

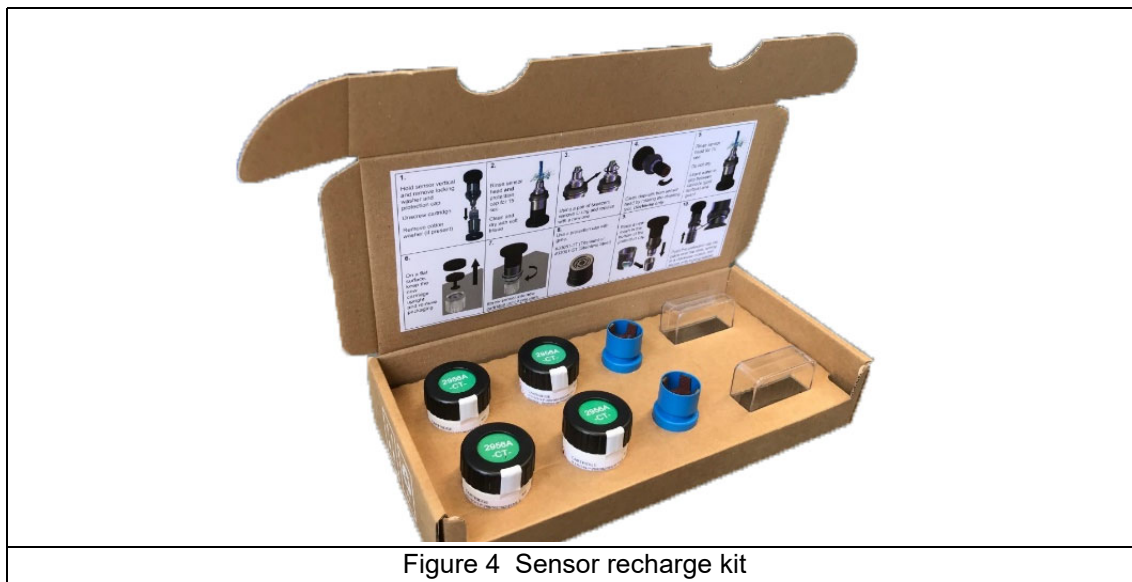

Figure 4 Sensor recharge kit

The kit contains:

- four recharge cartridges with pre-mounted membrane and electrolyte. The type of membrane mounted in the cartridge will be specific to the kit ordered
- anode cleaning tools
- a set of replacement O-rings
- a set of replacement Dacron® mesh patches

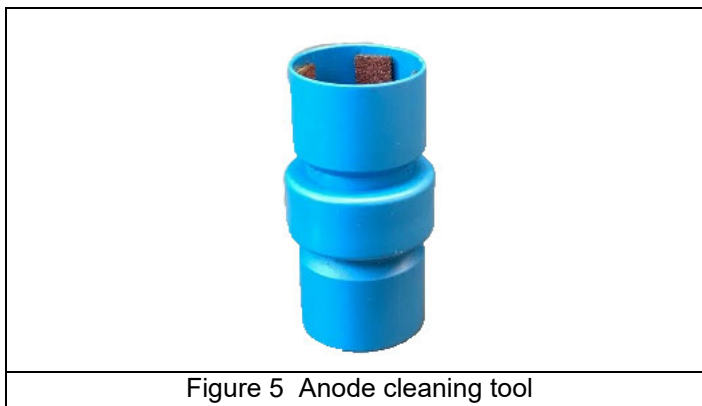

Figure 5 Anode cleaning tool

The blue anode cleaning tool ([Figure 5](#)) is used to clean the anode of any deposits or residue that may have formed. It is doubled-ended so it can be used for two membrane replacement processes, each end being used once.

The Dacron® mesh patches provide protection to the membrane.

## 3.2 Sensor components

The following illustration shows the assembled sensor with the storage cap and sensor collar removed and the exploded view of the main sensor components. To remove the storage cap, you will first have to unscrew and remove the sensor base.

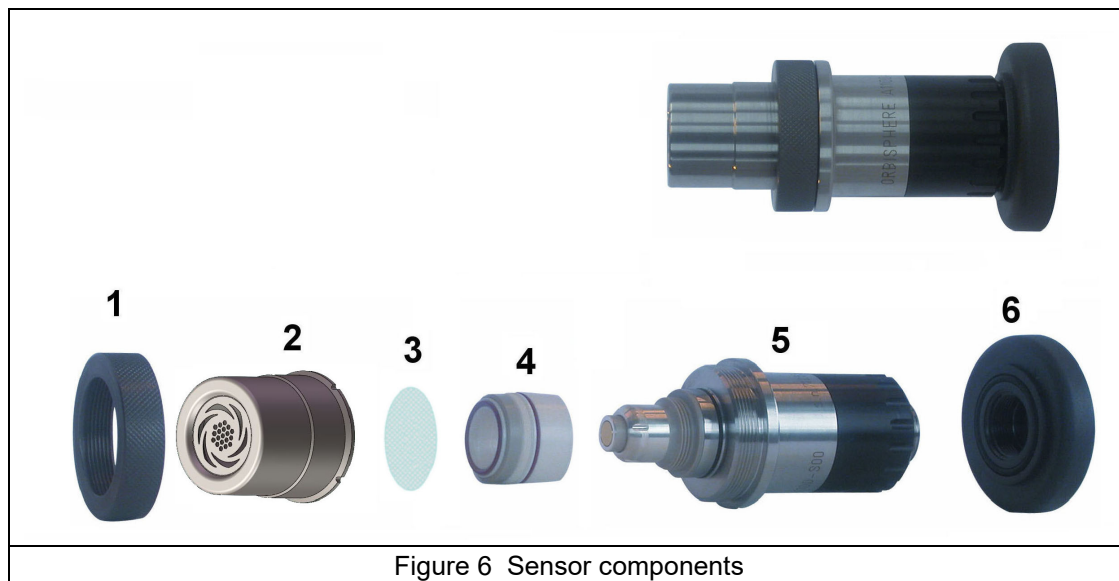

1 - Protection cap locking washer	4 - Cartridge containing electrolyte and membrane
2 - Protection cap	5 - Sensor body
3 - Dacron® mesh patch	6 - Plastic base

## 3.3 Basic principle of operation

In its simplest form, the electrochemical sensor consists of one center electrode (cathode) and one counter electrode (anode) immersed in an electrolyte solution which is separated from the liquid sample by a gas permeable membrane. An electronic circuit is linked to the anode and cathode. Through an applied voltage, current will flow between the anode and the cathode.

A guard ring electrode surrounds the center electrode in order to reduce the influence of other gases on the center electrode, and therefore improving analysis stability. The sensor head is covered with a protection cap to protect the membrane.

Ozone penetrating through the membrane into the cell reacts with the electrolyte which then undergoes a reaction at the cathode, causing a measurable electric current to flow. This current is proportional to the amount of gas entering the cell, which in turn is proportional to the partial pressure of gas in the sample outside the cell.

The result is shown as gas concentration, which can then be displayed with a choice of several measuring units, according to instrument setup.

The sensor also includes “smart sensor technology”, implemented using an RS485 interface.

The sensor electronics perform four functions:

- Apply constant voltage to the anode
- Measure the current flowing through the sensor
- Compensate for temperature variation in the liquid sample
- Convert the cell's electric current into an analog signal for sensor output



## ⚠ CAUTION



Multiple hazards. Only qualified personnel must conduct the tasks described in this section of the document.

### 4.1 Sensor preparation

## ⚠ CAUTION



Chemical exposure hazard. Obey laboratory safety procedures and wear all of the personal protective equipment appropriate to the chemicals that are handled. Refer to the current safety data sheets (MSDS/SDS) for safety protocols.

## ⚠ CAUTION



Chemical exposure hazard. Avoid all eye and skin contact with the electrolyte in the sensor and replacement cartridge. If eyes or skin come into contact with electrolyte, rinse immediately with water. In addition, the electrolyte can permanently stain clothing so exercise care in handling. It is highly recommended to wear protective gloves and glasses during this process.

Your C1100 electrochemical sensor has been thoroughly cleaned and tested at the factory before shipment. It has been shipped with a cartridge containing a membrane and electrolyte pre-installed to protect the sensor head. This cartridge must be removed and replaced with a new one prior to first use to make it fully operational. The new cartridge is included in the sensor recharge kit (Refer to additional details in [Sensor recharge kit on page 8](#)). You will also need one of the mesh patches included with the kit.

The following instructions detail the steps required to make the sensor operational. Should you have any questions, your Hach representative will be pleased to help.

**Note:** *It is advisable to perform this procedure with the plastic sensor base installed so as to avoid any damage to the connection socket and also to provide a suitable stand for the sensor when required.*

1. Hold the main body of the sensor and unscrew the protection cap locking washer by turning counter-clockwise. Remove it from the sensor and put to one side.

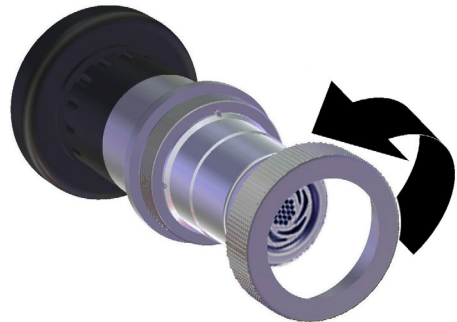

2. Pull/twist off the protection cap and put to one side. Remove the Dacron® mesh from inside the cap and discard it.

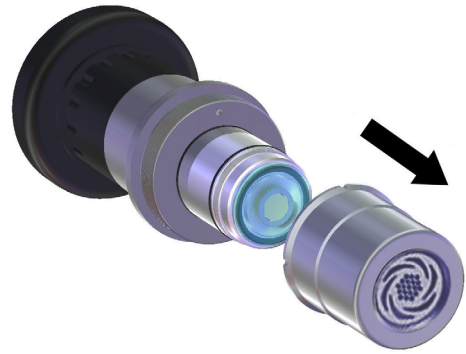

3. Hold the sensor with the membrane facing down to avoid spilling any electrolyte, then carefully unscrew the shipment cartridge. Drain the old electrolyte into a sink and flush away. Discard the shipment cartridge and membrane.

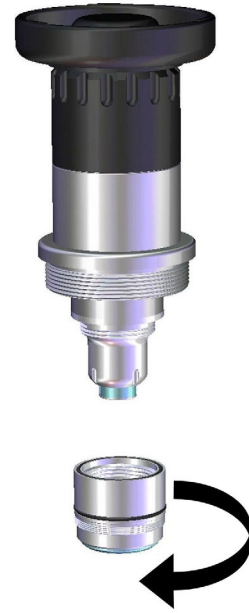

4. Rinse the sensor head under a tap for 15 seconds, aiming the jet of water directly onto the sensor head.
5. Do not dry the center electrode area, as the gap between cathode and guard should be left filled with water.



6. Place the recharge cartridge container on a flat work surface and, keeping the container upright to avoid spilling any of the electrolyte inside, carefully unscrew the top.
7. Remove the packing component from the center of the cartridge, making sure that the O-ring on top of the cartridge remains in place. If it comes away then replace it before continuing.
8. If there are any visible bubbles in the electrolyte, remove them using a stirring motion with the packing component.

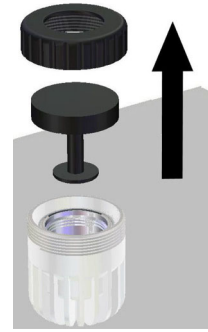

9. Hold the container steady between thumb and forefinger of one hand.
10. Lower the sensor into the container until the top of the anode is covered with electrolyte.

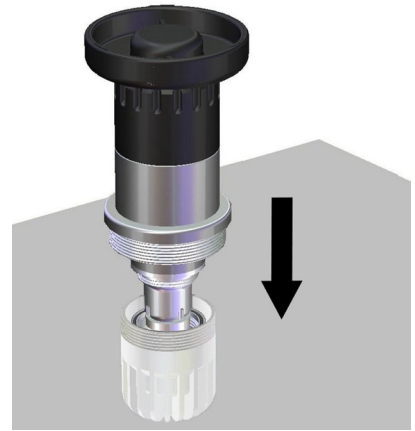

11. Gently screw the sensor clockwise into the replacement cartridge, applying minimum pressure to avoid any damage to the screw threads.



12. Continue turning until the cartridge is attached to the sensor, and the sensor is automatically released from the container.
13. The empty container, the screw top and packing component can be discarded.

**Note:** It is normal that some of the electrolyte will overflow from the replacement cartridge and into the plastic container.



14. Rinse the sensor under a tap for about 5 seconds to remove any excess electrolyte, then gently wipe with a soft tissue to ensure all parts are completely dry.
15. Drain the overflow electrolyte from the container into a sink and flush away.
16. Discard the used container.



17. Take a new Dacron® mesh patch from the box of O-rings in the recharge kit.
18. Place the mesh in the center of the protection cap. It is very important that the mesh is in the center of the protection cap and covering the entire grille.
19. Lower the sensor onto the protection cap making sure not to disturb the mesh.



**20.** Push the protection cap firmly into place, making sure one of the four slots in the protection cap fits over the small locking pin (highlighted right). If it is necessary to turn the protection cap to fit over the locking pin, ensure you only turn it **clockwise** to avoid unscrewing the cartridge.

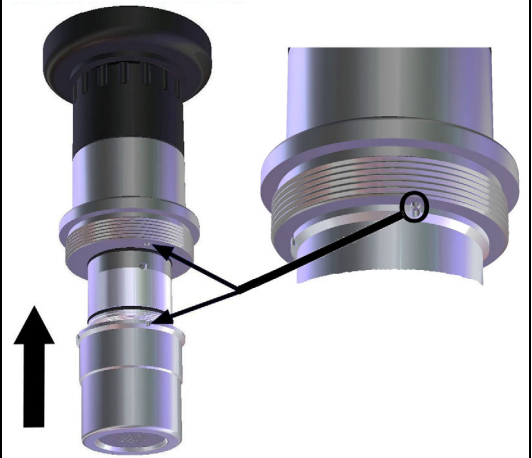

**21.** Finally, screw the protection cap locking washer back into place in a clockwise motion, and tighten finger tight.



## 4.2 Sensor installation

### 4.2.1 Sensor positioning information

The sensor must be installed in a socket or flow chamber that allows contact with the sample fluid to be analyzed.

The sensor and measuring instrument are connected by a cable and two 10-pin connectors. The standard sensor cable length is 3 meters though extension cables of up to 1000 meters are available. However, smart sensor technology is only available with distances of up to a maximum of 750 meters.

Ensure that the sensor will be mounted:

- perpendicular to the pipe
- horizontal
- on a horizontal pipe section (or on flow-ascending vertical pipe)
- minimum of 15 meters away from the pump's discharge side
- in a place where the sample flow is stable and rapid, and as far as possible from:
  - valves
  - pipe bends
  - the suction side of any pumps
  - a CO<sub>2</sub> injection system or similar

**Note:** *There may be situations where not all the above conditions can be met. If this is the case, or you have any concerns, please consult your Hach representative to appraise the situation and define the best applicable solution.*

### 4.2.2 Sensor insertion

- Insert the sensor straight into the flow chamber or socket. Do not twist the sensor.
- Hand tighten the attaching collar.
- Connect the sensor cable.
- Check for leaks; replace O-rings if product leaks are visible.

**Micro Volume Flow Chambers:**

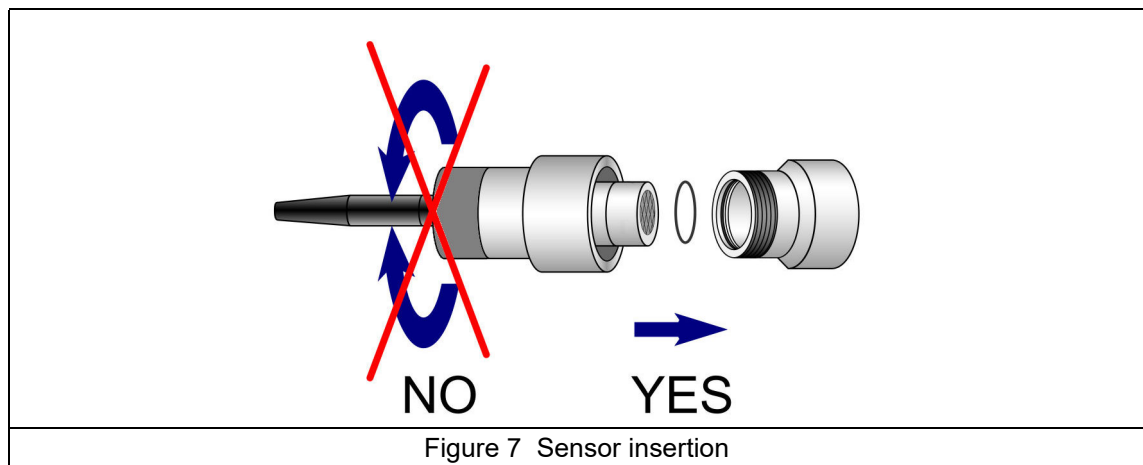

Figure 7 Sensor insertion

**Note:** *Do not twist the sensor when inserting it into a micro volume flow chamber.*

### 4.2.3 Sensor removal

- If not using the ORBISPHERE 32003 insertion/extraction valve (Refer to details [on page 18](#)) you will need to shut off the sample flow and drain the sampling circuit of liquid.
- Remove the sensor cable connected at the sensor end.
- Hold the sensor body in one hand to avoid rotation, and unscrew the collar with the other hand.
- Pull the sensor straight out of the socket or flow chamber.
- Install the sensor storage cap and sensor base (to protect the connection).

## 4.3 Mounting accessories

### 4.3.1 Weld-on stainless steel socket

The ORBISPHERE 29501 weld-on sensor socket can be used to install a sensor into a stainless steel pipe (min.  $\varnothing$  50 mm or 2"). When welding the socket to the pipe, check that setback between the pipe's inner diameter and the sensor tip does not exceed 4 mm (Refer to [Figure 8](#)).

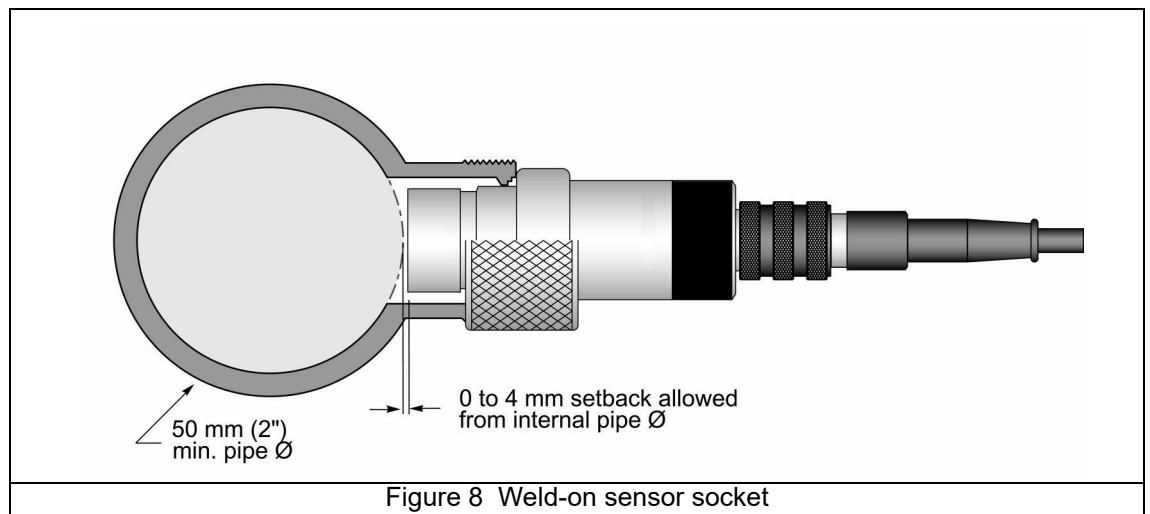

**Note:** Be sure to remove the two O-rings from the socket before welding and leave the sensor's stainless steel cap screwed on during welding to prevent thread distortion.

#### Recommendation:

To facilitate sensor removal and installation, we suggest installing the socket in a location where the liquid can be drained quickly and easily. By creating a one meter long piece of pipe (Refer to [Figure 9 on page 17](#)) with shut off valves at both ends, just a small volume of liquid needs to be drained to enable sensor removal.

Also, a precise sensor and socket installation can be performed in the workshop, and which can then be placed in the production line with minimal down time.

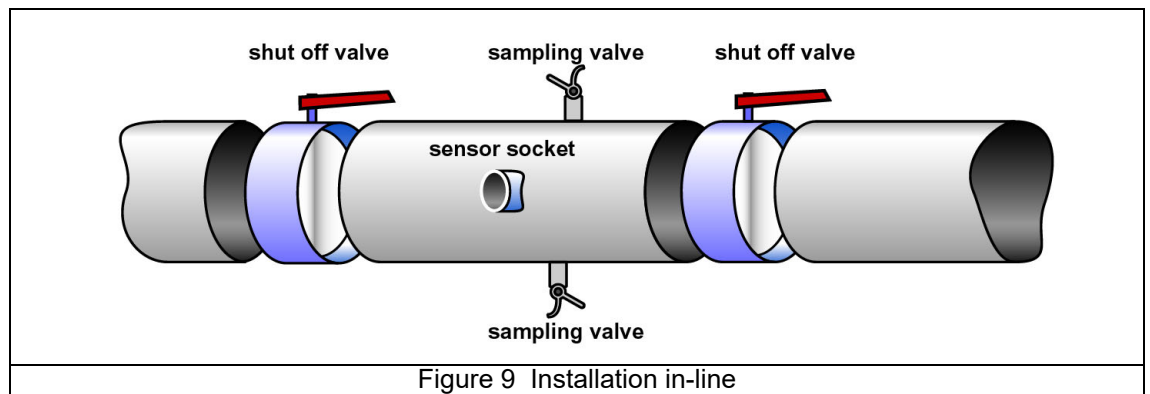

### 4.3.2 The 32003 insertion/extraction valve

The ORBISPHERE 32003 insertion/extraction valve (illustrated below) allows for sensor removal and installation without having to drain the fluid in the line. It can withstand a pressure of up to 20 bars, with the sensor in place or not.

Sensor insertion is made by inserting the sensor into the housing and tightening the retaining collar until it stops. As the retaining collar is tightened, the valve will open to allow the sample to flow past the sensor head. Remove the sensor by unscrewing the collar and pulling the sensor out. As the collar is unscrewed, the valve will automatically close to avoid any sample spillage.

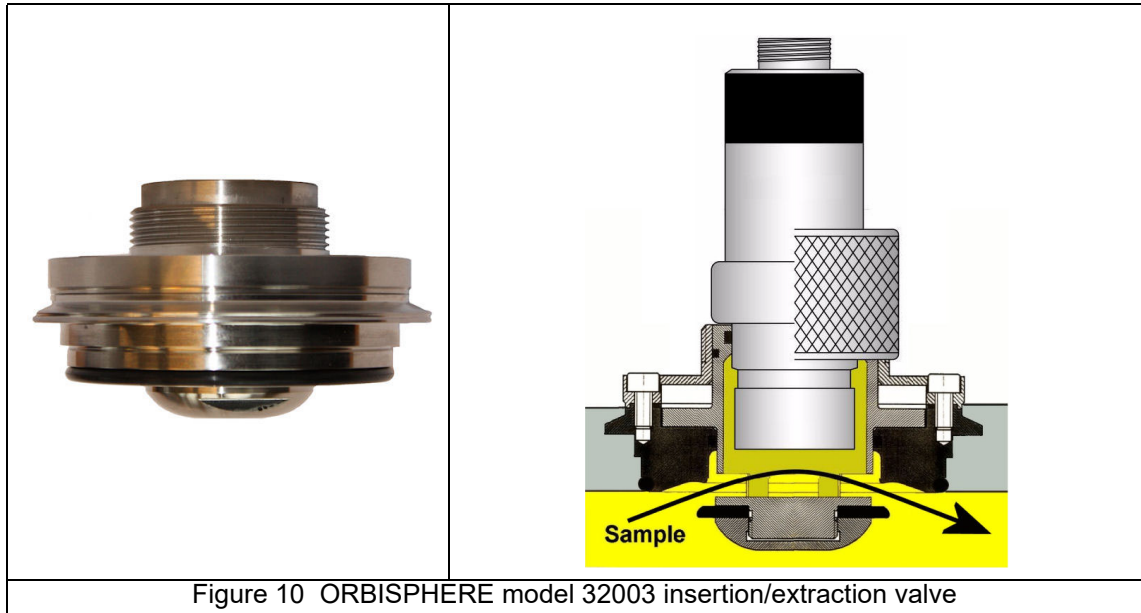

Figure 10 ORBISPHERE model 32003 insertion/extraction valve

The diagram above right, shows the sensor in a sample line with the valve open allowing the sample to run past the sensor head.

### 4.3.3 The 33095 sensor housing

The ORBISPHERE 33095 sensor housing is also available for use with the C1100 sensor but requires that the sample flow be turned off prior to insertion or removal of the sensor.

Sensor insertion is made by inserting the sensor into the housing and tightening the retaining collar until it stops. Removal is made by unscrewing the collar and pulling the sensor out. Be sure that the sample flow has been turned off before inserting or removing the sensor.

### 4.3.4 Tuchenhausen Varivent® in-line access unit

The following illustration shows the Tuchenhausen Varivent® In-Line Access Unit.



Figure 11 Tuchenhausen Varivent® in-line access unit

Purchasing a Tuchenhausen Varivent® in-line access unit, or an equivalent fitting with a 68 mm flange diameter from the fitting manufacturer, is required to make use of the ORBISPHERE model 32003 sensor housing device detailed above.

### 4.3.5 ORBISPHERE flow chambers

The ORBISPHERE 32001.xxx flow chambers are used to draw liquid samples past the sensor. They are available in several materials, depending on the application.

They connect to 6-mm or ¼" stainless steel tubing by means of two Swagelok™ fittings. If necessary, copper or plastic tubing with low permeability can be substituted. Stainless steel tubing is normally enough to hold the assembly in place, but for a more stable installation, a large U-bolt can be used to mount the flow chamber to a support.

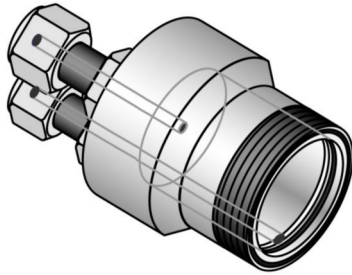
	<p>Dimensions of sensor and flow chamber assembly :</p> <ul style="list-style-type: none"> <li>• Width: 50 mm</li> <li>• Height: 210 mm</li> </ul> <p>(add 100 mm for connection length)</p>
-----------------------------------------------------------------------------------	----------------------------------------------------------------------------------------------------------------------------------------------------------------------------------------------

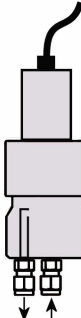
Orientation of flow chamber	
<p>Vertically, with connections down and sensor up</p> <ul style="list-style-type: none"> <li>- Center connection is the inlet</li> <li>- Outer connection is the outlet</li> </ul>	

The connection diagram below is a recommended installation that allows for measuring and calibrating without having to disconnect a line manually. "A" and "B" represent 3-way valves.

For measuring, calibration gas inlets and outlets are shut off. During calibration, the flow is reversed to drive the remaining sample out. The calibration gas enters at the "sample out" port and exits at the "sample in" port, as shown.

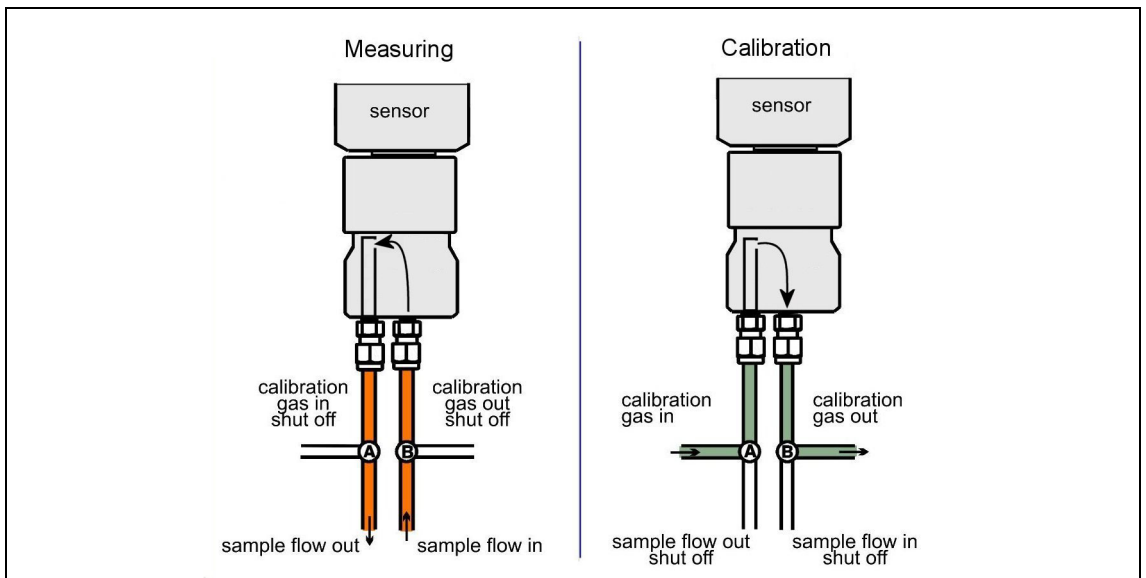



The manufacturer recommends to calibrate the Orbisphere ozone sensor at six months intervals and the internal pressure sensor of the analyzer at one year intervals. Do sensor maintenance before sensor calibration. Refer to [6.1 Maintenance on page 23](#).

Connect the sensor to Orbisphere Model 410 or 510 analyzers for calibration. Refer to the analyzer documentation for additional calibration information.

## 5.1 O<sub>3</sub> sensor calibration

The sensor is either in contact with:

- Air at atmospheric pressure (In Air). In 100% water saturated air.
- O<sub>3</sub> at known concentration (Direct Value). The gas can be dissolved or not.

The procedure is the same as for the O<sub>2</sub> sensor. In the case of the In air calibration, the sensor measures O<sub>2</sub> during calibration. The O<sub>3</sub> coefficient is deduced taking into account how the sensor behaves in O<sub>2</sub>. As a different voltage is used at the anode to measure O<sub>2</sub> and O<sub>3</sub>, the O<sub>3</sub> measurement takes a long time to stabilize.

To facilitate the follow up after an O<sub>3</sub> in air calibration, negative values can be displayed.

## 5.2 In Air calibration procedure

Calibrate the sensor as follows:

**Note:** After the sensor maintenance is completed, make sure that the sensor is connected to the analyzer a minimum of 30 minutes before calibration.

1. Remove the sensor from the flow chamber or in-line device.
2. Unscrew the sensor collar. Let the sensor adjust to room temperature.
3. Fully dry the sensor. If necessary, use a paper tissue to remove moisture from the membrane.
4. Put the sensor in a beaker or similar container with a water layer in the bottom to have a 100% saturated water atmosphere. Make sure that the sensor does not touch the water.
5. In the main menu of the analyzer, select **Calibration > Gas sensor > Calibration**.
6. Push **Modify** and set **Calibration mode** to **In air**. Then, push **OK**.
7. Push **Start** to start the calibration. A calibration screen shows in the analyzer display. The display shows the calibration parameters and the sensor readings: temperature, barometer and current. The messages show in the "Results" box at the top of the screen.
  - **% ideal current**—Percentage of the current compared with the ideal current for the used membrane. If this value is not within the accepted range, from 50% to 150%, an error message shows a calibration failure. A warning message shows when the value is near the boundaries, but calibration is correct.
  - **% last calibration**—Ratio between the current measurement and the previous sensor calibration.
  - **% variation**—Variation for the last three measurements, which is the stability of the measurements. For precise calibration, the variation percentage must be less than 0.03%.
8. Keep the sensor in air until the reading is stable. The average time for a correct calibration is 20 to 30 minutes.
9. When the reading is stable or the analyzer shows that a calibration failure occurred, press **Finish** to end the calibration. If the calibration was successful, accept the new calibration parameters. If a calibration failure occurred, a dialog box shows the failure information. Do the sensor maintenance or replace the membrane and do the calibration again.

10. Put the sensor into the flow chamber or mounting again. Use the sensor collar to attach the sensor to the installation location.

**Note:** After calibration, the measurement reading may be negative or unstable because of the change of polarization when the sensor is switched from calibration to measurement mode. The sensor will stabilize in 12-24 hours based on the ozone concentration measured.

## 6.1 Maintenance

### ⚠ CAUTION



Multiple hazards. Only qualified personnel must conduct the tasks described in this section of the document.

The table that follows lists the items necessary for a sensor maintenance:

Part No.	Description
2959	Electrolyte for oxygen sensors, 50-mL bottle
29781	Cathode polishing powder (part no.29331) and cloth (part no. 2934)
32301	Electrochemical cleaning and regeneration center (see below)
40089	Tweezers for maintenance kits
DG33303	Cleaning tool for sensor polishing for A110X and C1100 sensors only
DG33629	Cleaning tool for sensor polishing for GA2X00 sensors only
DG33619	Regeneration Cell for GA2X00/A1100 or C1100 sensors
DG33620	Orbisphere EC sensor support for cleaning

**Note:** When the sensor is used in a high level hydrogen sample, the electrochemical cleaning and regeneration center 32301 is not necessary. For all other conditions, the electrochemical cleaning and regeneration center 32301 is a necessary.

### 6.1.1 Electrochemical cleaning and regeneration center

The ORBISPHERE 32301 is a very efficient cleaning and regeneration tool for electrochemical sensors. This tool reverses the electrochemical process that is taking place in the sensor cell during normal operation. The reversal of the electrochemical process removes oxidation and at the same time regenerates the surface of the electrodes. In addition, the regeneration center offers a continuity tester to check the sensor electronics.



Figure 12 Model 32301 cleaning and regeneration center

Use of this tool is recommended for a noticeably extended sensor life. Detailed information on how to use the cleaning and regeneration center is included in the 32301 Operator Manual.

## 6.1.2 Membrane replacement and sensor head cleaning

<b>⚠ CAUTION</b>	
	Chemical exposure hazard. Obey laboratory safety procedures and wear all of the personal protective equipment appropriate to the chemicals that are handled. Refer to the current safety data sheets (MSDS/SDS) for safety protocols.

<b>⚠ CAUTION</b>	
	Chemical exposure hazard. Avoid all eye and skin contact with the electrolyte in the sensor and replacement cartridge. If eyes or skin come into contact with electrolyte, rinse immediately with water. In addition, the electrolyte can permanently stain clothing so exercise care in handling. It is highly recommended to wear protective gloves and glasses during this process.

A sensor recharge kit is required as it contains all the components necessary for this membrane replacement and sensor head cleaning process. Refer to [3.1.3 Sensor recharge kit on page 8](#).

**Note:** It is advisable to perform this procedure with the plastic sensor base installed so as to avoid any damage to the connection socket and also to provide a suitable stand for the sensor when required.

1. Hold the main body of the sensor and unscrew the protection cap locking washer by turning counter-clockwise. Remove it from the sensor and put to one side.
2. Pull/twist off the protection cap. Remove the Dacron<sup>®</sup> mesh from the cap and discard.
3. Hold the sensor with the membrane facing down to avoid spilling any electrolyte, then carefully unscrew the old cartridge. Drain the old electrolyte into a sink and flush away. Discard the old cartridge and membrane.

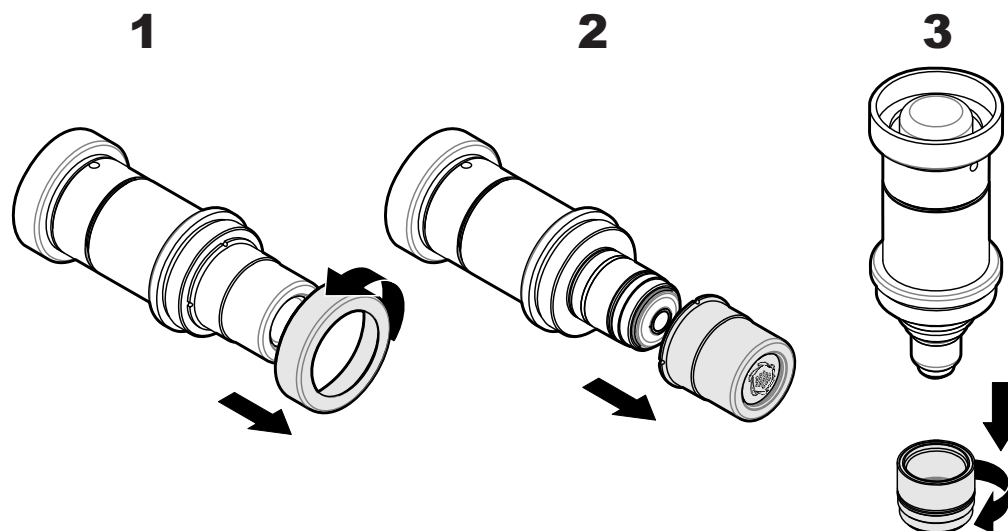

4. Rinse the sensor head under a tap for 15 seconds to remove any remaining electrolyte and shake dry. With a soft tissue gently clean around the guard area (indicated right) and then wipe off any excess moisture from the sensor to ensure all parts are completely dry. Repeat this rinse and dry process with the protection cap.
5. Clean the anode using the cleaning tool supplied. Place the tool over the sensor head. Clean by rotating the cleaning tool over the sensor head for a few seconds, **in a clockwise direction only**.

6. Remove the tool and tap it face down on a flat work surface to remove any powdery deposit. Check the sensor to ensure that all deposits have been removed from the anode. If not, repeat step 5. until the anode regains its bright silver appearance.

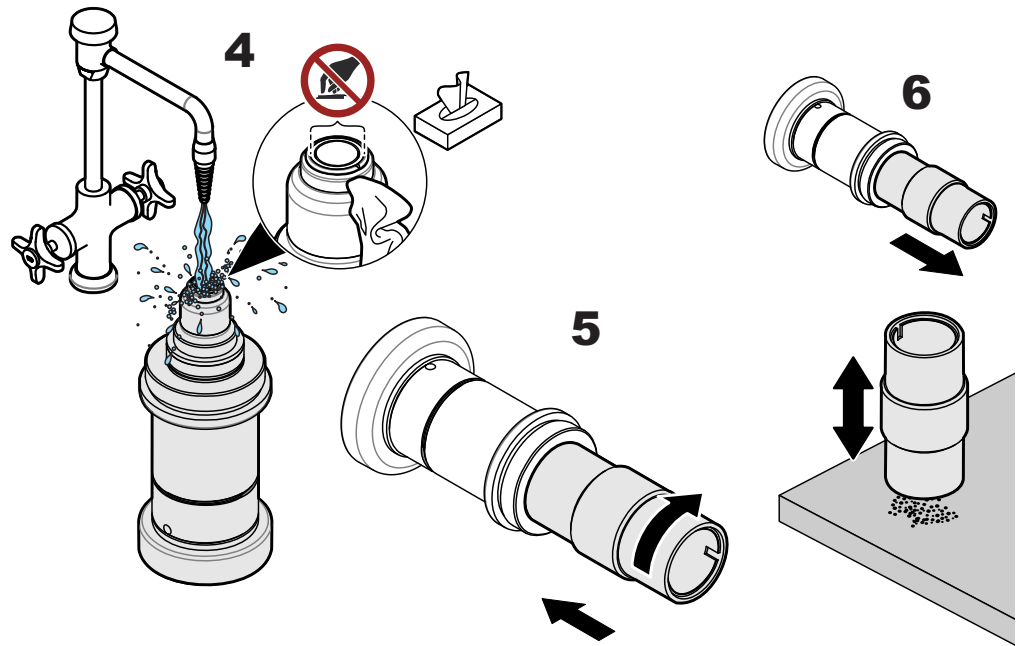

7. Rinse the sensor head under a tap for 15 seconds, aiming the jet of water directly onto the sensor head. Do not dry the center electrode area, as the gap between cathode and guard should be left filled with water.
8. On the clean polishing cloth (2934) do the steps that follow:
  - a. Add a few drops of water.
  - b. Spread a little of the polishing powder (29331) to form a grey, milky liquid.
9. Screw the polishing tool (DG33303) onto the top of the sensor.

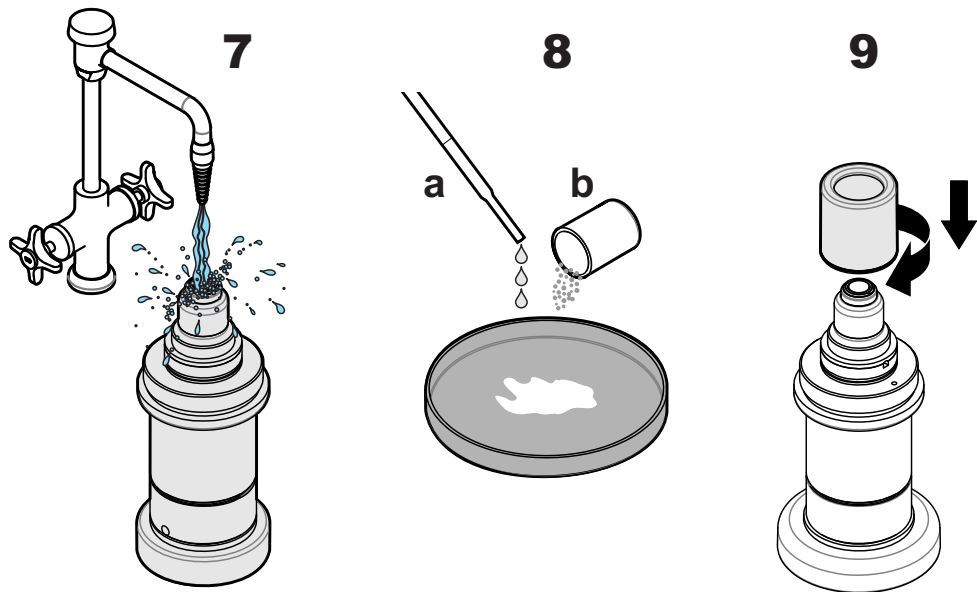

- Polish the electrodes by moving the sensor face in a circular direction against the liquid in the polishing cloth for about 30 seconds.
- Remove the polishing tool from the sensor. Remove any polish deposits by rinsing the sensor head under a tap for 30 seconds, aiming the jet of water directly onto the sensor head.
- Remove the plastic base from the bottom of the sensor and connect the sensor to the sensor cleaning and regeneration center (32301).

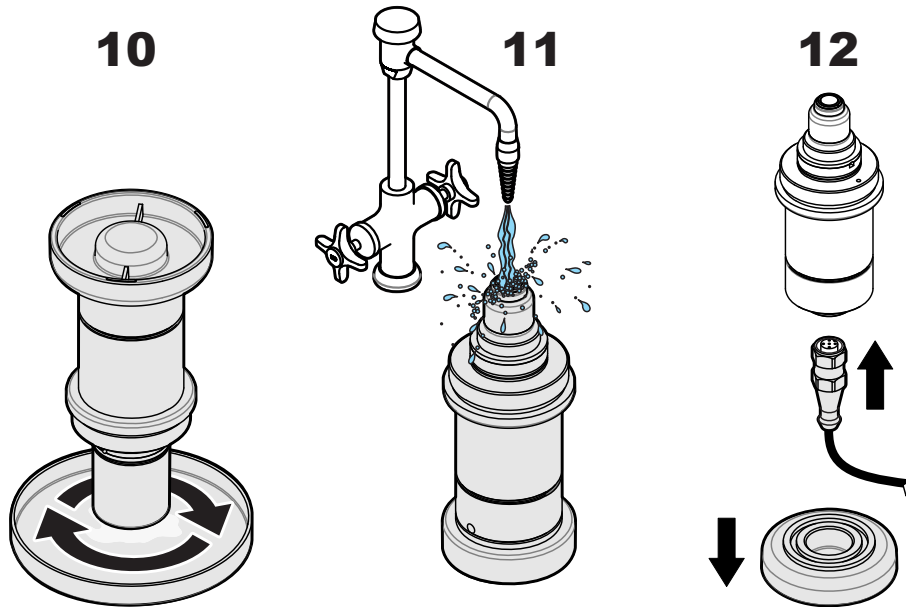

- Push the cleaning tool over the sensor head. Pour enough electrolyte (2959) into the cleaning tool until it completely covers all the electrodes.

**Note:** For DG33619 regeneration cell, screw the regeneration cell on the sensor head.

- On the sensor cleaning and regeneration center, turn the knob to the **Anode** position and press the **TIMER** switch. A red warning light will come on and remain on for 60 seconds while cleaning takes place.
- At the end of the 60 second cleaning process, check for an abundant stream of bubbles that should rise from the anode. If this does not happen, press **TIMER** again.

**Note:** The development of bubbles is a sure sign of a clean electrode.

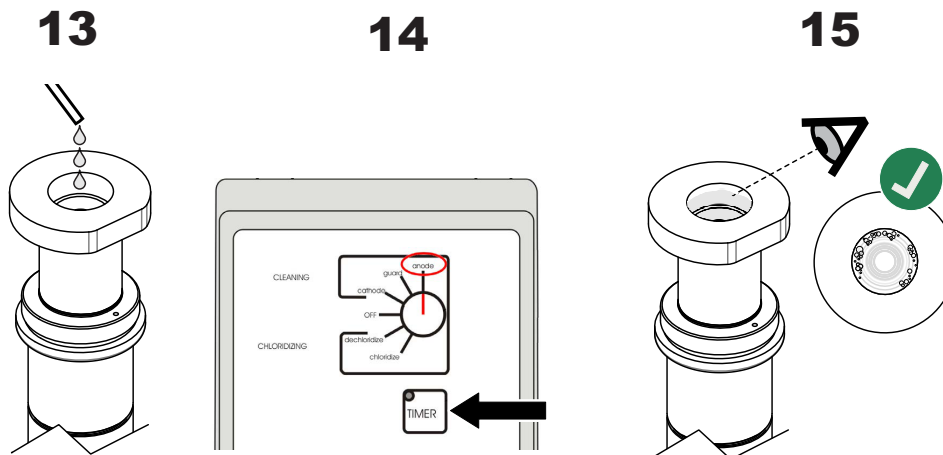

16. On the sensor cleaning and regeneration center, turn the knob to the **Guard** position and press the **TIMER** switch. Again, watch for the formation of bubbles and repeat the cleaning process if necessary.
17. On the sensor cleaning and regeneration center, turn the knob to the **Cathode** position and press the **TIMER** switch. Again, watch for the formation of bubbles and repeat the cleaning process if necessary.
18. When cleaning is complete, unplug the sensor from the cleaning center and re-install the plastic sensor base for the rest of the procedure. Remove any remaining electrolyte by rinsing the sensor head with tap water for 60 seconds, aiming the jet of water directly onto the sensor head.

**Note:** For DG33619 regeneration cell, unscrew the regeneration cell from the sensor head.

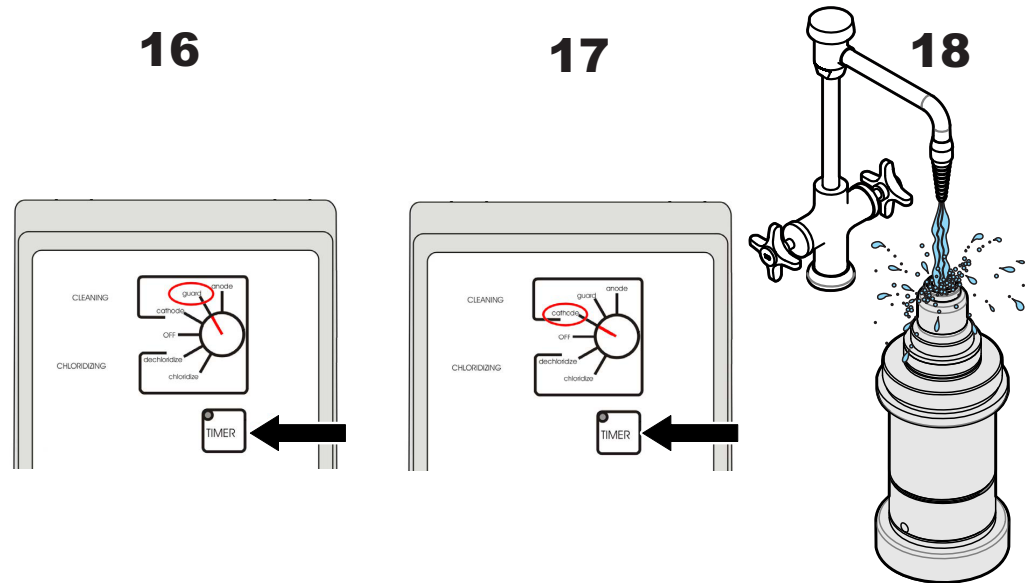

19. With the help of a pair of tweezers, remove the old O-ring from the sensor body. Replace the O-ring with a new one from the recharge kit.

**Note:** When cleaning is complete, it is very important to ensure your finger does not come into contact with the cathode (golden surface) as it could leave greasy deposits on the surface.

20. Place the recharge cartridge container on a flat work surface and, keeping the container upright to avoid spilling any of the electrolyte inside, carefully unscrew the top. Remove the packing component from the center of the cartridge, and make sure that the O-ring remains in place on top of the cartridge. If it comes away then replace it before continuing. If there are any visible bubbles in the electrolyte, remove them using a stirring motion with the packing component.

21. Hold the container steady between thumb and forefinger of one hand. Lower the sensor into the container until the top of the anode is covered with electrolyte.

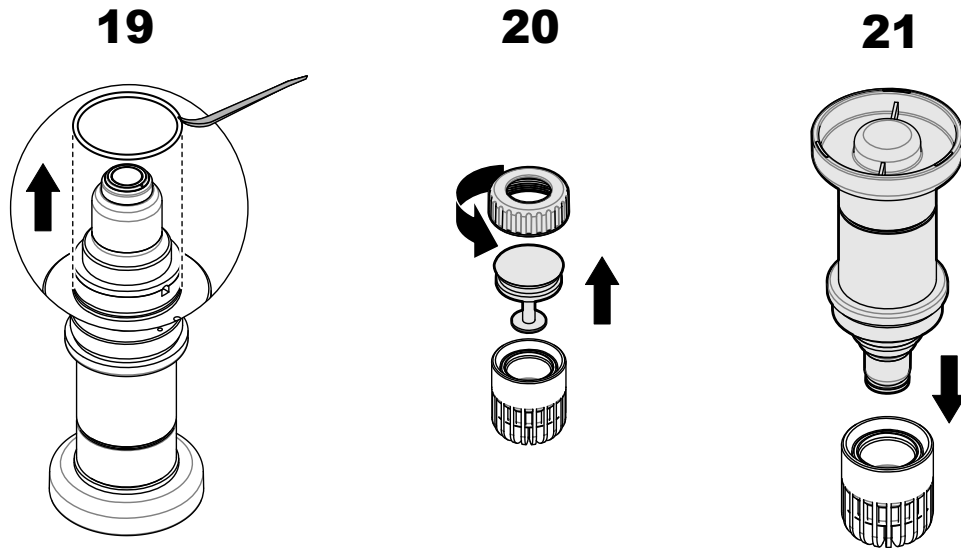

22. Gently screw the sensor clockwise into the replacement cartridge, applying minimum pressure to avoid any damage to the screw threads.
23. Continue turning until the cartridge is attached to the sensor, and the sensor is automatically released from the container. The empty container, the screw top and packing component can be discarded.

**Note:** It is normal that some of the electrolyte will overflow from the replacement cartridge and into the plastic

24. Rinse the sensor under a tap for about 5 seconds to remove any excess electrolyte, then gently wipe with a soft tissue to ensure all parts are completely dry. Drain the overflow electrolyte from the container into a sink and flush away. Discard the used container.

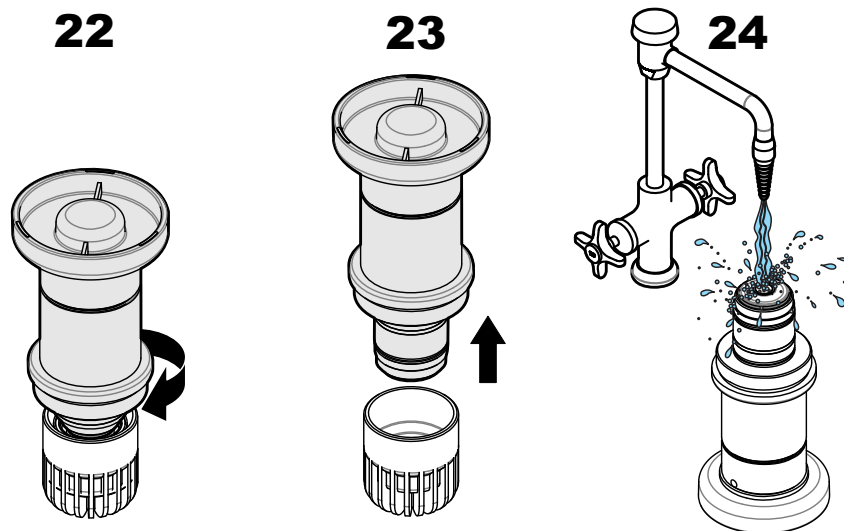

- 25.** Take a new Dacron® mesh patch from the box of O-rings in the recharge kit. Place the mesh in the center of the protection cap. It is very important that the mesh is in the center of the protection cap and covering the entire grille. Lower the sensor onto the protection cap making sure not to disturb the mesh.
- 26.** Push the protection cap firmly into place, making sure one of the four slots in the protection cap fits over the small locking pin (highlighted right). If it is necessary to turn the protection cap to fit over the locking pin, ensure you only turn it clockwise to avoid unscrewing the cartridge.
- 27.** Finally, screw the protection cap locking washer back into place in a clockwise motion, and tighten finger tight.

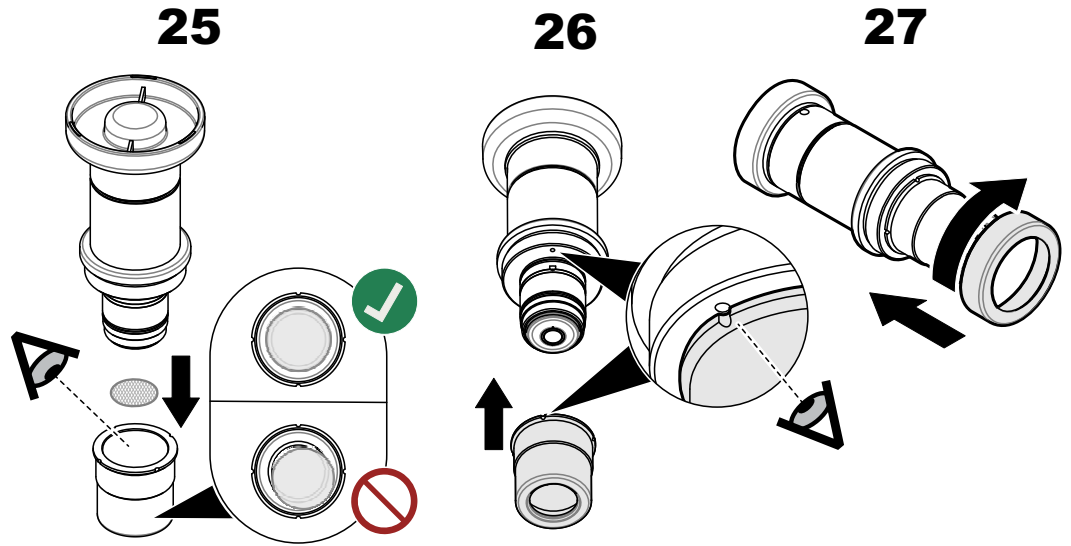

## 6.2 Troubleshooting

### 6.2.1 Ozone sensor

When the O<sub>3</sub> sensor has been properly calibrated using the Orbisphere measuring instrument, the sensor has to settle down for up to 24 hours when used in very low O<sub>3</sub> concentration conditions.

Table 3 Troubleshooting - Ozone sensor		
Problem	Probable Cause	Possible Solution
Sensor won't calibrate, even after cleaning and/or membrane change.	Instrument internal barometric pressure sensor needs calibration.	Calibrate internal barometer against a certified barometer. Do not correct for sea level !
	Wet membrane interface.	Wipe dry with a tissue and re-calibrate.
"0000" O <sub>3</sub> levels displayed.	Wrong reading scale "XXXX" selected for display unit.	Change reading scale by selecting "X.XXX, XX.XX or XXX.X".
Unexpected/incorrect dissolved O <sub>3</sub> reading.	High residual current.	If concentration is significantly higher than low limit, try a sensor service.
	Insufficient flow rate.	Regulate flow equivalent to membrane specified levels.
	Length of sample line allows O <sub>3</sub> time to react.	Reduce length of sample tubing.
	Doesn't match lab samples.	Take samples at close proximity to sensor.
Calibration is out of specification or response time is too slow.	Sensor is not set up correctly.	Check the sensor parameters on the instrument. Calibrate the sensor.
	The temperature measurement is not correct.	Control the temperature with an external reference. Calibrate the sensor.
	Barometric pressure is incorrect.	Calibrate the barometric pressure sensor with the instrument. Calibrate the sensor.
	Cartridge is not installed correctly on sensor.	Make sure that the cartridge assembly is firmly attached onto the sensor and that the membrane is tight. Calibrate the sensor.
	Sensor electrodes are dirty.	Clean the sensor with the ORBISPHERE 32301 cleaning and regeneration center as shown in this section. Calibrate the sensor.
	Sensor maintenance is necessary.	Install a new sensor cartridge to replace the membrane as shown in this section. Calibrate the sensor.

## ⚠ WARNING



Personal injury hazard. Use of non-approved parts may cause personal injury, damage to the instrument or equipment malfunction. The replacement parts in this section are approved by the manufacturer.

*Note: Product and Article numbers may vary for some selling regions. Contact the appropriate distributor or refer to the company website for contact information.*

### 7.1 Sensor spare parts

**Table 4 Sensor spare parts**

Part N°	Description
C1100-S00	Electrochemical ozone sensor, Stainless Steel, with Smart capability
C1100-S0S	Electrochemical ozone sensor, Stainless Steel, with Smart capability
C1100-T00	Electrochemical ozone sensor, Titanium, with Smart capability
C1100-LP0	Electrochemical ozone sensor, Stainless Steel, with Smart capability, for low pressure
28104	Stainless steel sensor collar
28129	Delrin storage cap (sensor storage cap)
29006.1	Viton O-ring set for standard flow chambers (32001, 32002, 32007, 32009) and 29501 sensor socket. (34x2 mm & 28x2 mm)
29006.2	Kalrez O-ring set for standard flow chambers (32001, 32002, 32007, 32009) and 29501 sensor socket. (34x2 mm & 28x2 mm)
29006.4	Nitril O-ring set for standard flow chambers (32001, 32002, 32007, 32009) and 29501 sensor socket. (34 x 2 mm & 28 x 2 mm)
29037	Regeneration cell for 32301 electrochemical sensor cleaning and regeneration unit
32205	Sensor support (base) for ORBISPHERE 31xxx and x1100 family EC sensors
32301	Electrochemical sensor cleaning and regeneration unit
33051-ST	Stainless steel 28mm cap with grille for ORBISPHERE x1100 family EC sensors
33051-TT	Titanium 28mm cap with grille for ORBISPHERE x1100 family EC sensors

### 7.2 Recharge kits for C110x sensors

**Table 5 Recharge kits for C110x sensors**

Part N°	Description
29552A-CT	Recharge kit of 4 pre-filled cartridges with premounted 29552A membranes for C1100 ozone sensors. Includes O-rings, cleaning tools and Dacron® mesh patches
2956A-CT	Recharge kit of 4 pre-filled cartridges with premounted 2956A membranes for C1100 ozone sensors. Includes O-rings, cleaning tools and Dacron® mesh patches
2957A-LP	Recharge kit of 4 pre-filled cartridges with premounted 2957A membranes for C1100 ozone sensors. Includes O-rings, cleaning tools and Dacron® mesh patches

### 7.3 Flow chambers and installation devices

**Table 6 Flow chambers and installation devices**

Part N°	Description
29501.1	Sensor socket for welding to SS pipe, with Viton O-ring
32001.110	Flow chamber in stainless steel (316) with 6 mm fittings. Supplied with Viton O-rings
32001.111	Flow chamber in stainless steel (316) with ¼" fittings. Supplied with Viton O-rings
32001.140	Flow chamber in Hastelloy with 6 mm fittings. Supplied with Viton O-rings
32001.141	Flow chamber in Hastelloy with ¼" fittings. Supplied with Viton O-rings

**Table 6 Flow chambers and installation devices**

<b>Part N°</b>	<b>Description</b>
32001.150	Flow chamber in Titanium with 6 mm fittings. Supplied with Viton O-rings
32001.151	Flow chamber in Titanium with ¼" fittings. Supplied with Viton O-rings
32001.170	Flow chamber in Monel with 6 mm fittings. Supplied with Viton O-rings
32001.171	Flow chamber in Monel with ¼" fittings. Supplied with Viton O-rings
32003	Sensor insertion device; for use with Tuchenhagen adapter
33095	28 mm stationary housing for installation on Varinline® access units

## 7.4 Certificates

**Table 7 Certificates**

<b>Part N°</b>	<b>Description</b>
33181	C1100 Material certificate EN 10204 2.2
CERT3.1/C1100	C1100 Material certificate EN 10204 3.1
MES/C1100	DESC Measurement certificate, indicating that the sensor performs within specific measurement norms for the system in question
MES/SY1/C1100	DESC Measurement certificate, indicating that the system performs within specific measurement norms for the system in question

**HACH COMPANY World Headquarters**

P.O. Box 389, Loveland, CO 80539-0389 U.S.A.  
Tel. (970) 669-3050  
(800) 227-4224 (U.S.A. only)  
Fax (970) 669-2932  
orders@hach.com  
www.hach.com

**HACH LANGE GMBH**

Willstätterstraße 11  
D-40549 Düsseldorf, Germany  
Tel. +49 (0) 2 11 52 88-320  
Fax +49 (0) 2 11 52 88-210  
info-de@hach.com  
www.de.hach.com

**HACH LANGE Sàrl**

6, route de Compois  
1222 Vérenaz  
SWITZERLAND  
Tel. +41 22 594 6400  
Fax +41 22 594 6499

