

Solitax sc Turbidity & Suspended Solids Sensors

Applications

- Drinking water
- Wastewater
- Beverage
- Industrial water
- Power



Accurate, colour-independent suspended solids and turbidity measurements

Greater accuracy, less maintenance

Hach®'s Solitax sc sensors provide accurate, colour-independent measurement of turbidity and suspended solids in drinking water, wastewater and industrial process applications. A self-cleaning device prevents biological growth and interference of gas bubbles. This system's reliable performance and full data communication capability help improve process control and reduce treatment costs associated with polymer use, digester volume, and sludge handling.

Excellent correlation to laboratory analysis

Solitax sc sensors show an exceptional correlation to laboratory analysis. On-line measurement not only saves time on manual analysis, but also provides critical real-time measurements that can be used to operate the plant more efficiently.

Fully serviceable sensors

Conventional turbidity and suspended solids sensors are potted and are discarded when they no longer function. Solitax sc sensors are fully serviceable, which often doubles the useful life of the sensor.

Easy one-point calibration

Factory calibrated in conformity with DIN EN ISO 7027 for long-term calibration stability. Calibration is easy with a simple correction factor procedure.

Multi-channel, multi-parameter system

Multiple Solitax sc sensors can be installed on one Hach SC Controller. The same controller can also accommodate any combination of parameters. All of Hach's model sc sensors are "plug and play" with no complicated wiring or set-up procedure necessary.

Technical Data*

	For insertion in pipes		For immersion in open tanks		
Model	Solitax inline sc	Solitax highline sc	Solitax t-line sc	Solitax ts-line sc	Solitax hs-line sc
Parameter	Suspended Solids, Turbidity	High Range Suspended Solids, Turbidity	Turbidity	Suspended Solids, Turbidity	High Range Suspended Solids, Turbidity
Measuring range	TSS content: 0.001 mg/L - 50 g/L Turbidity: 0.001 - 4000 NTU	TSS-content: 0.001 - 500 g/L; 0.001 - 500,000 mg/L (the upper range is dependent on the sample property) Turbidity: 0.001 - 4000 NTU	Turbidity: 0.001 - 4000 NTU	TSS content: 0.001 mg/L - 50 g/L Turbidity: 0.001 - 4000 NTU	TSS-content: 0.001 - 500 g/L; 0.001 - 500,000 mg/L (the upper range is dependent on the sample property) Turbidity: 0.001 - 4000 NTU
Units	Turbidity: User selectable - NTU, FNU, or TE/F Suspended Solids: User selectable - g/L, mg/L, ppm, or % solids				
Accuracy	Turbidity up to 1000 NTU: without calibration < 5% of the measured value ±0.01 NTU with calibration < 1% of the measured value ±0.01 NTU				
Repeatability	TSS content: < 3 % Turbidity: < 1 %				
Response time	1 - 300 s adjustable				
Calibration method	Turbidity: Formazin or Stabcal Standard (at 800 NTU). Suspended Solids: Sample specific, based on gravimetric TSS analysis with a correction factor procedure.				
Certifications	CE				
Flow	Max. 3 m/s (the presence of air bubbles affects the measurement)				
Operating temperature range	0 - 40 °C				
Pressure range	Stainless steel insertion sensor: <6 bar or <60 m	PVC: <1 bar or <10 m	Stainless steel immersion sensor: <6 bar or <60 m PVC: <1 bar or <10 m		
Material	Optics carrier and sleeve: stainless steel 1.4571 or black PVC Wiper arm: stainless steel 1.4581 Wiper blade: silicone (standard) Optional: FKM/FPM (LZX578) Wiper shaft: stainless steel 1.4571 Threaded cable fitting: stainless steel 1.4305 or white PVC				
Weight	Immersion: Stainless steel: 1.38 kg; PVC: 0.52 kg Insertion: Stainless steel: 2.4 kg				
Cable length	10 m (optional extension cables available)				

*Subject to change without notice.

Principle of Operation

Solitax sc ts-line sensor with dual-beam optics and added backscatter detector

- Dual infrared light beams. LED light source transmits light at 45° to sensor face.
- Nephelometric photoreceptors detect light at 90° to the transmitted light beam.
- Backscatter photoreceptor (included on all models except the Solitax sc t-line) detects light at 140° to the transmitted light beam to measure suspended solids in heavily loaded sample streams.
- Self-cleaning wiper, optional.
- T-line probes measure turbidity only. TS, HS, inline, and highline sensors measure either turbidity or suspended solids.

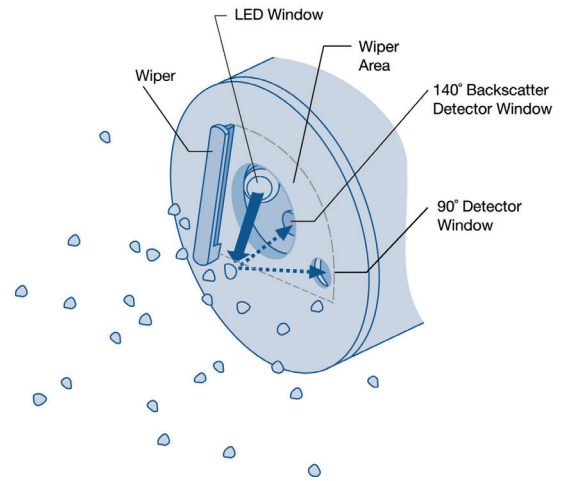

Dimensions

Hach Solitax sc sensors can be fixed to the rim of the tank for immersion applications or inserted directly through the sidewall of a pipeline for insertion applications. A variety of installation kits are available.

Solitax sc Insertion Probe

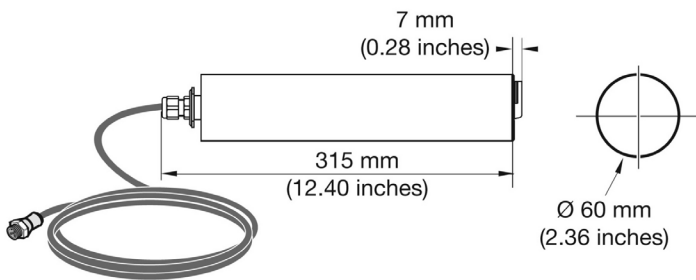

Solitax sc Immersion Probe

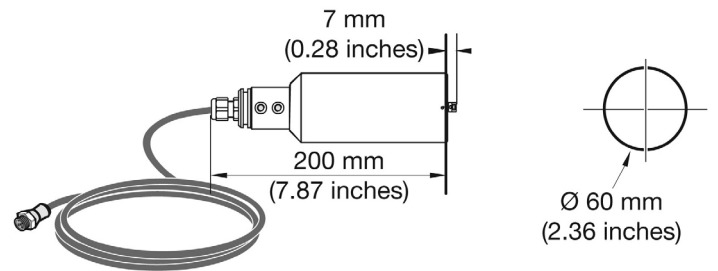

Installation/Mounting

*Installation for mounting Solitax sc for immersion in open tanks.
(Stainless steel pole mount kit, Prod. No. LZY714.99.53120)*

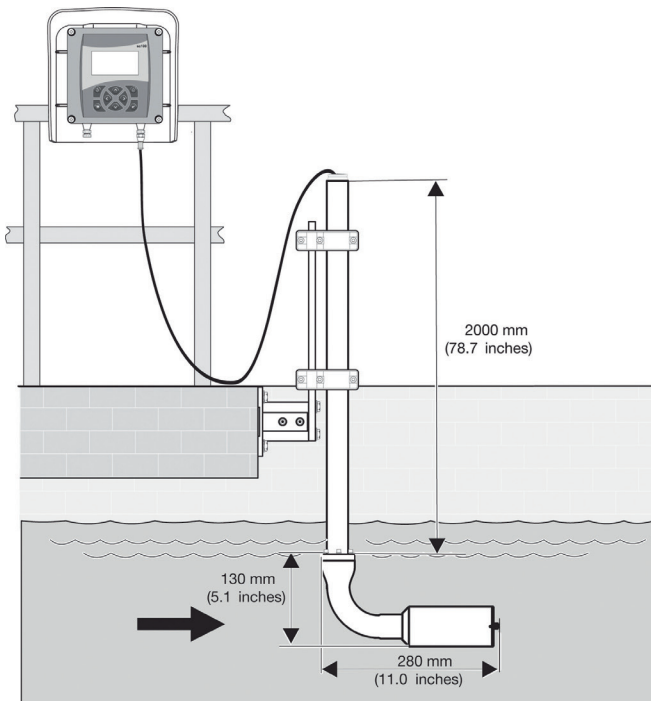

*Fixture with ball valve for mounting Solitax sc models
inline and highline sensors in pipes, minimum pipe size 100 mm (4-in.)
Prod. No. LZX337, max pressure 6 bar;
Prod. No. LZX936, max. pressure 1 bar.*

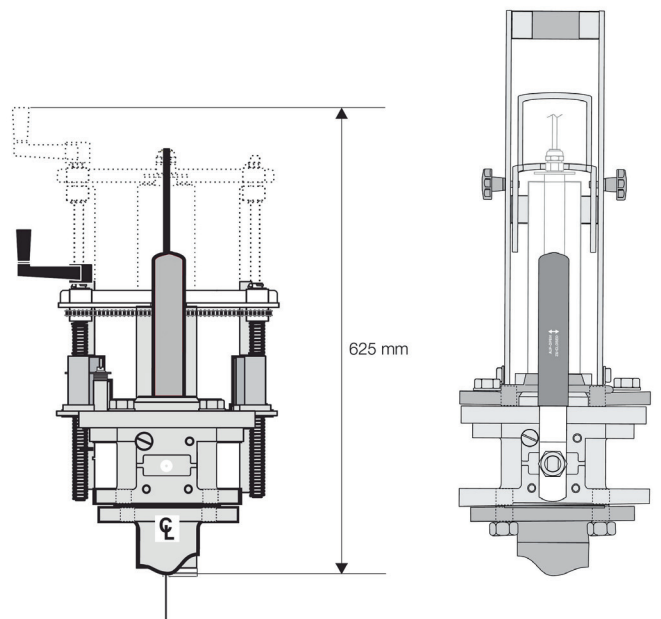

Order Information

Solitax sc Probes

Immersion Probes

- LXV423.99.10000** Solitax t-line sc Turbidity immersion probe, 0.001 - 4000 NTU, with wiper, PVC
- LXV423.99.12000** Solitax t-line sc Turbidity immersion probe, 0.001 - 4000 NTU, w/o wiper, PVC
- LXV423.99.10100** Solitax ts-line sc Turbidity (0.001-4000 NTU) and Suspended Solids (0.001-50 g/L) immersion probe, with wiper, PVC
- LXV423.99.12100** Solitax ts-line sc Turbidity (0.001-4000 NTU) and Suspended Solids (0.001-50 g/L) immersion probe, w/o wiper, PVC
- LXV423.99.00100** Solitax ts-line sc Turbidity (0.001-4000 NTU) and Suspended Solids (0.001-50 g/L) immersion probe, with wiper, stainless steel
- LXV423.99.02100** Solitax ts-line sc Turbidity (0.001-4000 NTU) and Suspended Solids (0.001-50 g/L) immersion probe, w/o wiper, stainless steel
- LXV423.99.10200** Solitax hs-line sc Turbidity (0.001-4000 NTU) and Suspended Solids (0.001-500 g/L) immersion probe, with wiper, PVC
- LXV423.99.12200** Solitax hs-line sc Turbidity (0.001-4000 NTU) and Suspended Solids (0.001-500 g/L) immersion probe, w/o wiper, PVC
- LXV423.99.00200** Solitax hs-line sc Turbidity (0.001-4000 NTU) and Suspended Solids (0.001-500 g/L) immersion probe, with wiper, stainless steel
- LXV423.99.02200** Solitax hs-line sc Turbidity (0.001-4000 NTU) and Suspended Solids (0.001-500 g/L) immersion probe, w/o wiper, stainless steel

Insertion Probes

- LXV424.99.00100** Solitax inline sc Turbidity (0.001-4000 NTU) and Suspended Solids (0.001-50 g/L) built-in probe, with wiper, stainless steel
- LXV424.99.02100** Solitax inline sc Turbidity (0.001-4000 NTU) and Suspended Solids (0.001-50 g/L) built-in probe, w/o wiper, stainless steel
- LXV424.99.00200** Solitax highline sc Turbidity (0.001-4000 NTU) and Suspended Solids (0.001-500 g/L) built-in probe, with wiper, stainless steel
- LXV424.99.02200** Solitax highline sc Turbidity (0.001-4000 NTU) and Suspended Solids (0.001-500 g/L) built-in probe, w/o wiper, stainless steel

Installation Accessories

- LZY714.99.53120** Stainless Steel pole mount kit for Solitax t-line, ts-line, and hs-line sc immersion sensors, including 10 cm base and 2 m pole with sensor adapter
- LZX337** Stainless steel ball valve safety armature/extraction fitting for Solitax inline and highline sc probes, for filled and pressurised pipes, max. operating pressure 6 bar
- LZX936** Stainless steel ball valve armature for Solitax inline and highline sc probes, for filled but pressureless pipes
- LZX660** Non-coped stainless steel welding flange for insertion kit
- LZX661** Non-coped carbon steel welding flange for insertion kit

Hach Service

With Hach Service, you have a global partner who understands your needs and cares about delivering timely, high-quality service you can trust. Our Service Team brings unique expertise to help you maximise instrument uptime, ensure data integrity, maintain operational stability, and reduce compliance risk.