

F
 E
 D
 C
 B
 A

BOTTOM CONNECTIONS VIEW

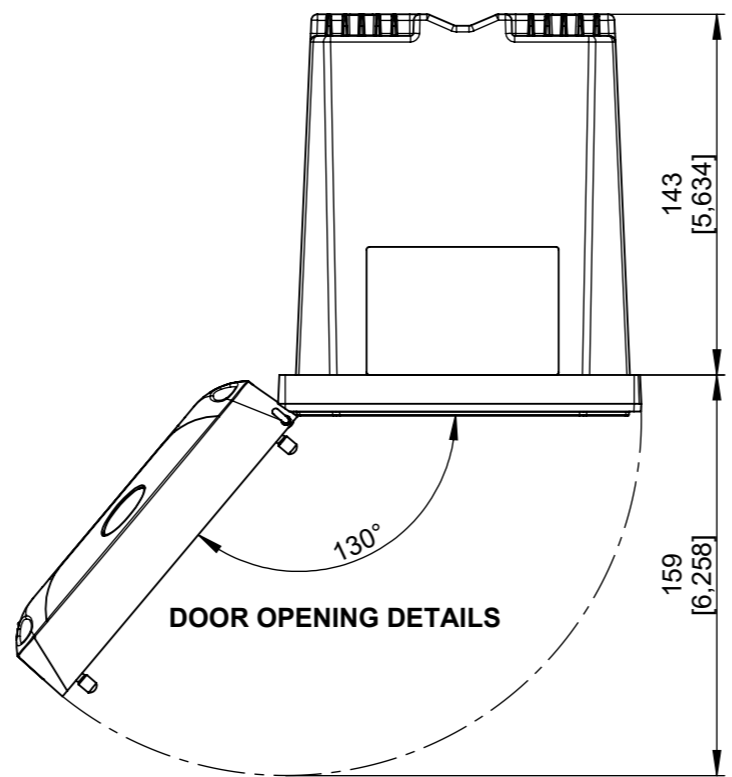
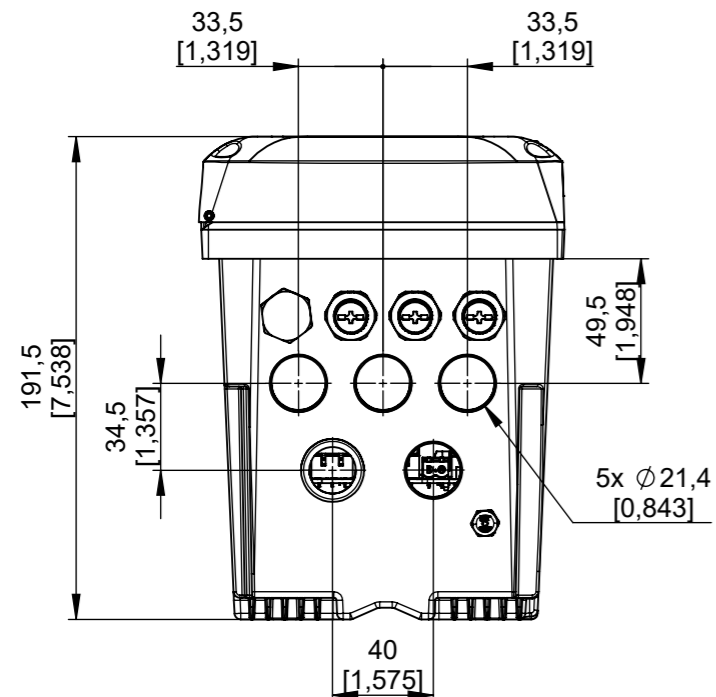

GENERAL INFORMATION:

1. CONTROLLER OPERATING TEMPERATURE : -20 TO +60 C (- 4 TO +140 F); 95% HUMIDITY, NON CONDENSING.
2. CONTROLLER STORAGE TEMPERATURE: -20 TO +70 C (- 4 TO +158 F); 95% RELATIVE HUMIDITY, NON CONDENSING.
3. ENCLOSURE: NEMA 4x / IP66 METAL ENCLOSURE WITH A CORROSION RESISTANT FINISH.
4. CONTROLLER WEIGHT: 2.0 Kg (4.3 lb).

CUSTOMER CONNECTIONS
ITEMS REMOVED FOR CLARITY

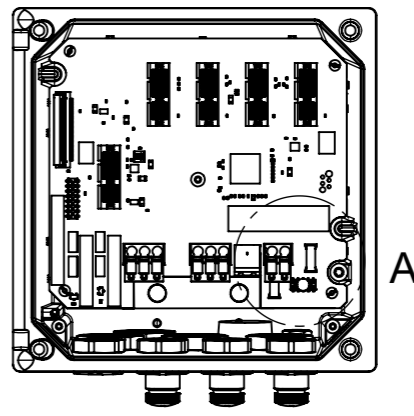

F
 E
 D
 C
 B
 A

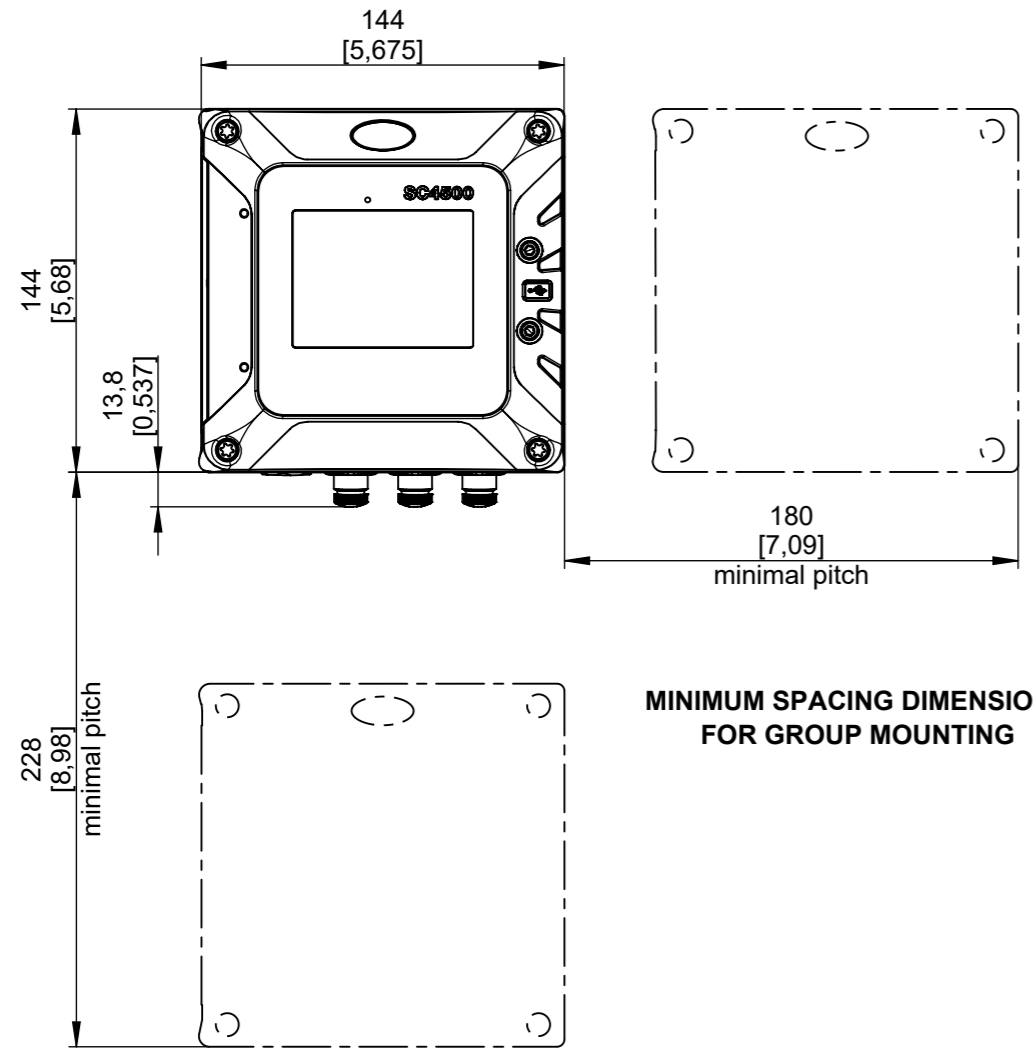

MOUNTING DIMENSIONS

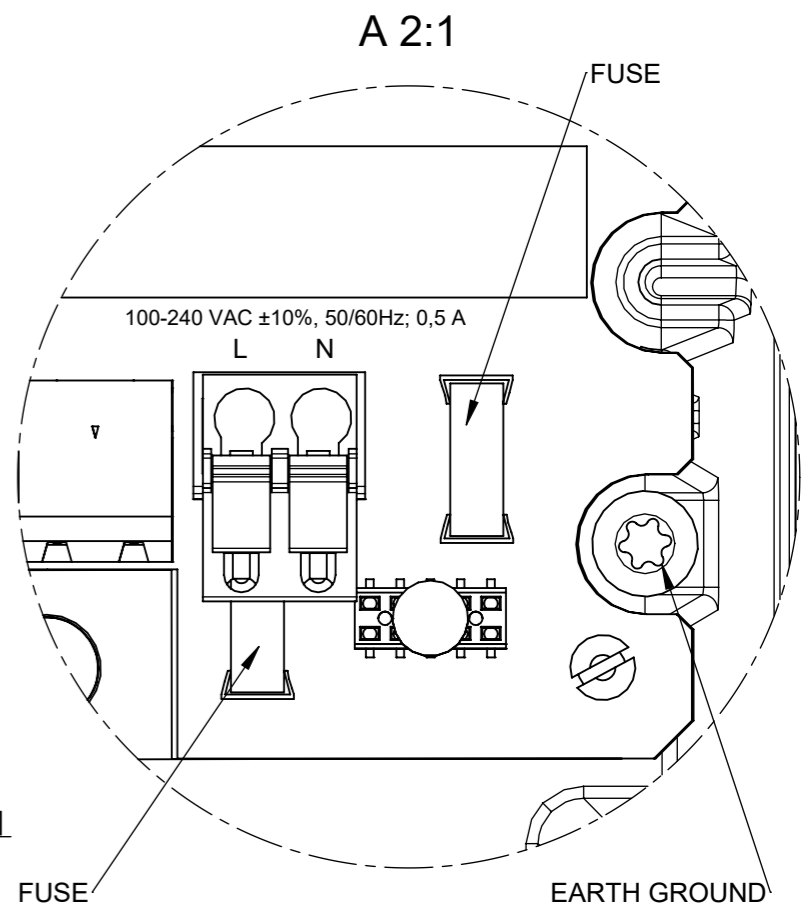
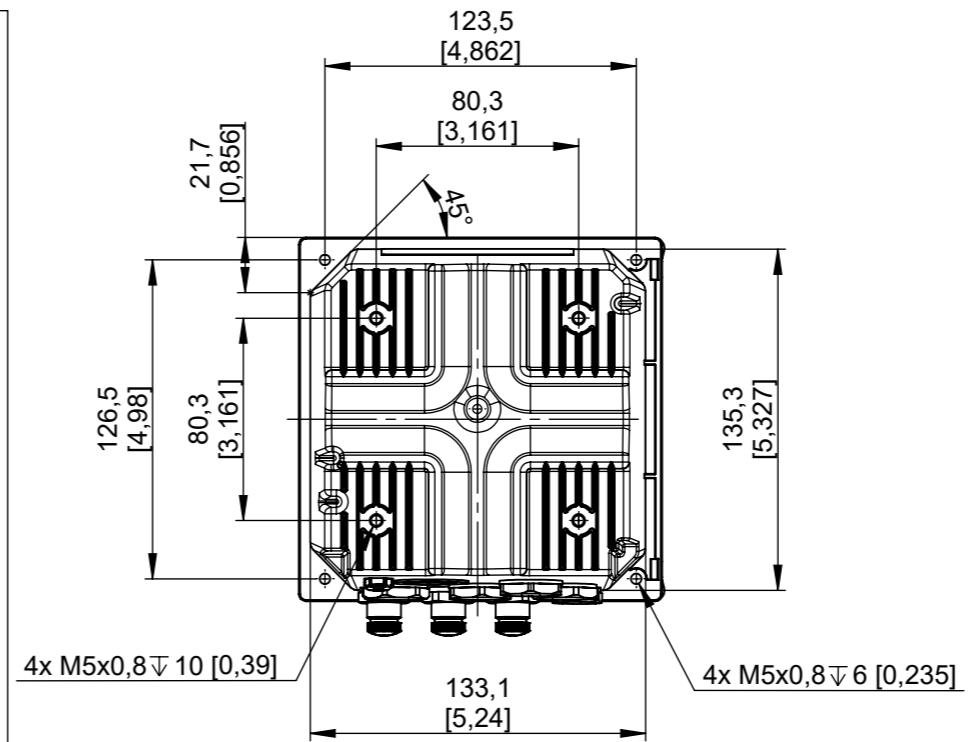

		Maße ohne Toleranzangaben General Tolerance		Maßeinheit/Dim.unit mm		Verwendung Application LXG525		Maßstab Scale 1:3 / 2:1	
				Volumen/Volume		Werkstoff, Halbzeug: Material:			
		Datum/Date		Name		Benennung / Designation			
		Bearb./Dwn. 29.01.2021		BPav		Transmittal SC4500			
		Gepr./Chk. 09.02.2021		Lie.		Zeichnungsnummer / Dwg.No.:		Blatt/Sheet 1	
		Rev.-Chk.				LXV525.TD.10000		v. of Bl. Sht. 2	
01		09.02.2021		BPav		Ers. für		Ausgabe A3	
Zust./Rev.		Änderung / Rev.No.		Datum/Date		Name			

