

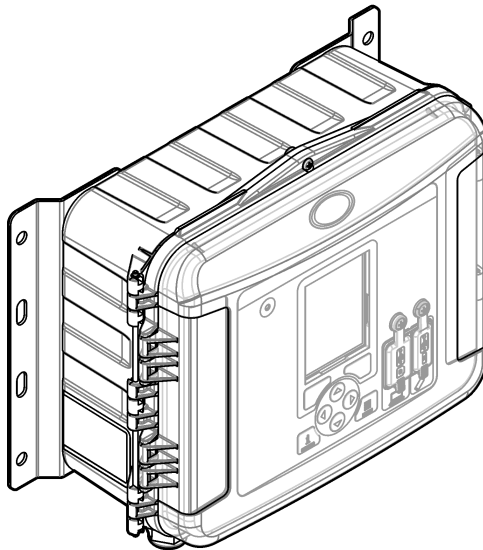


DOC343.53.80573

# FL1500 Flow Logger

07/2024, Edition 2

**User Manual**





<b>Section 1 Specifications</b> .....	3
<b>Section 2 General information</b> .....	4
2.1 Safety information .....	4
2.1.1 Use of hazard information .....	4
2.1.2 Precautionary labels .....	5
2.1.3 EMC compliance .....	5
2.1.4 Chemical and biological safety .....	6
2.2 Product overview .....	6
2.3 Product components .....	8
<b>Section 3 Installation</b> .....	9
3.1 Installation guidelines .....	9
3.2 Mechanical installation .....	9
3.2.1 Mounting .....	9
3.3 Electrical installation .....	12
3.3.1 Open the cover .....	12
3.3.2 Open the access door .....	13
3.3.3 Wiring information .....	13
3.3.4 Connect to power .....	14
3.3.4.1 Connect to AC power .....	14
3.3.4.2 Connect to DC power .....	16
3.3.5 Connect to sensors .....	17
3.3.5.1 Installation for Flo-Dar or Flo-Tote sensors .....	19
3.3.6 Connect to optional devices .....	20
3.3.7 Connect to the relays .....	23
3.3.8 Connect to the inputs and outputs .....	24
3.3.9 Connect to an RS485 network .....	26
<b>Section 4 Startup</b> .....	27
4.1 Supply power .....	27
<b>Section 5 User interface and navigation</b> .....	27
5.1 Keypad description .....	27
5.1.1 Show the data as a slideshow .....	28
5.2 Main menu overview .....	28
5.3 Status indicators .....	28
<b>Section 6 Operation</b> .....	29
6.1 Configuration options—Instrument or PC .....	29
6.2 Configure the general settings .....	29
6.3 Set up the sensors—Setup Wizard .....	30
6.4 Flo-Dar setup .....	30
6.5 Flo-Tote setup .....	31
6.6 AV9000S setup .....	32
6.7 US9000 setup .....	32
6.8 BL9000 bubbler setup .....	33
6.9 pH sensor setup .....	34
6.10 Calibrate the sensors .....	34
6.11 Configure data logging .....	35

## Table of Contents

---

6.12	Configure the alarms .....	35
6.13	Configure the software totalizer .....	37
6.14	Configure the mechanical totalizer .....	37
6.15	Configure the inputs and outputs .....	38
6.16	Configure flow pacing for connected samplers .....	38
6.17	Configure network communications .....	39
6.18	Data management .....	39
6.18.1	View data .....	39
6.18.2	Save data to a USB stick .....	39
6.18.3	Import or export the instrument settings .....	40
<b>Section 7</b>	<b>Maintenance</b> .....	<b>40</b>
7.1	Maintenance schedule .....	40
7.2	Clean the instrument .....	40
7.3	Replace the fuses .....	41
7.4	Replace the internal desiccant .....	42
7.5	Remove the cover (optional) .....	43
<b>Section 8</b>	<b>Troubleshooting</b> .....	<b>44</b>
<b>Section 9</b>	<b>Replacement parts and accessories</b> .....	<b>44</b>

## Section 1 Specifications

Specifications are subject to change without notice.

Specification	Details
Dimensions (H x W x D)	25.4 × 29.2 × 12.1 cm (10.0 × 11.5 × 4.75 inch), enclosure with cover only 25.4 × 31.8 × 13.3 cm (10.0 × 12.5 × 5.25 inch), enclosure with cover and mounting bracket
Enclosure	NEMA 4X, IP 66 (with and without removable cover)
Weight	3.2 kg (7.0 lb)
Pollution degree	2
Installation category	II
Protection class	I
Power requirements	AC: 100–240 VAC, 50/60 Hz, 15 watts DC: 10–30 VDC, 15 watts
Backup battery option	12 VDC lead acid battery
Fuses	AC power: two T 3.15 A, 250 VAC; DC power: one F 10 A, 250 VDC; Relays: two T 3.15 A, 250 VAC
Operating conditions	Temperature: Logger only: –20 to 60 °C (–4 to 140 °F) Logger and AC battery backup: –15 to 40 °C (5 to 104 °F) 0 to 95% non-condensing relative humidity Altitude: 2000 m (6560 ft) maximum
Storage conditions	–40 to 70 °C (–40 to 158 °F)
Data storage	Maximum 829,440 measurements (180 days storage, 5-minute logging intervals for 16 parameters); data wraps when full
Communications	USB and RS485 (Modbus)
USB ports	USB A port for USB memory stick only, USB B port for PC only
Display	QVGA, color
Sensor options	Flo-Dar, SVS, Flo-Tote 3, AV9000S (bare wire), US9001, US9003, BL9000, digital differential pH, rain gauge
Sensor connections	Basic model: 2; Advanced model: 4
Totalizer	Software totalizer, scalable Connection for external mechanical totalizer (advanced model only)
Time-base accuracy	Maximum 1 second per day
Analog input	One 0/4–20 mA input (current input mode: 0/4–20 mA; 18 VDC maximum; 108 Ω and 0.4 V maximum loop burden). Refer to <a href="#">Connect to the inputs and outputs</a> on page 24 for wiring details.
Analog outputs	Two (basic model) or three (advanced model) 0/4–20 mA outputs (0/4–20 mA current loop; external loop power 18 VDC maximum or internal loop power 14 VDC minimum, 18 VDC maximum; loop burden 3.6 V maximum at 25 mA). Refer to <a href="#">Connect to the inputs and outputs</a> on page 24 for wiring details.
Relays	Two high voltage relays; Form C, SPDT, 20–230 VAC, 2.0 A

Specification	Details
Digital inputs (advanced model only)	Two digital inputs; each digital input has a positive terminal and a shared common with an input resistance of 120 kΩ and maximum input voltage of 30 V. The default threshold is 1.5 V. When the optional user-supplied threshold is used, the threshold is set at 50% of the voltage applied to the threshold pin (0 to 25 VDC)
Digital outputs (advanced model only)	Two digital outputs; low voltage contact closures mapped to alarm events ( $\pm 30$ VDC or 20 VAC-rms at 0.15 A maximum); optional pull-up resistor to externally-supplied logic level (0 to 30 VDC)
Certifications	CE, cETLus, RCM
Warranty	1 year (EU: 2 years)

## Section 2 General information

In no event will the manufacturer be liable for damages resulting from any improper use of product or failure to comply with the instructions in the manual. The manufacturer reserves the right to make changes in this manual and the products it describes at any time, without notice or obligation. Revised editions are found on the manufacturer's website.

### 2.1 Safety information

The manufacturer is not responsible for any damages due to misapplication or misuse of this product including, without limitation, direct, incidental and consequential damages, and disclaims such damages to the full extent permitted under applicable law. The user is solely responsible to identify critical application risks and install appropriate mechanisms to protect processes during a possible equipment malfunction.

Please read this entire manual before unpacking, setting up or operating this equipment. Pay attention to all danger and caution statements. Failure to do so could result in serious injury to the operator or damage to the equipment.

Make sure that the protection provided by this equipment is not impaired. Do not use or install this equipment in any manner other than that specified in this manual.

#### 2.1.1 Use of hazard information

##### **▲ DANGER**

Indicates a potentially or imminently hazardous situation which, if not avoided, will result in death or serious injury.

##### **▲ WARNING**

Indicates a potentially or imminently hazardous situation which, if not avoided, could result in death or serious injury.

##### **▲ CAUTION**






Indicates a potentially hazardous situation that may result in minor or moderate injury.

##### **NOTICE**

Indicates a situation which, if not avoided, may cause damage to the instrument. Information that requires special emphasis.

## 2.1.2 Precautionary labels

Read all labels and tags attached to the instrument. Personal injury or damage to the instrument could occur if not observed. A symbol on the instrument is referenced in the manual with a precautionary statement.

	This is the safety alert symbol. Obey all safety messages that follow this symbol to avoid potential injury. If on the instrument, refer to the instruction manual for operation or safety information.
	This symbol indicates that a risk of electrical shock and/or electrocution exists.
	This symbol, when noted on the product, identifies the location of a fuse or current limiting device.
	This symbol indicates that the marked item requires a protective earth connection. If the instrument is not supplied with a ground plug on a cord, make the protective earth connection to the protective conductor terminal.
	Electrical equipment marked with this symbol may not be disposed of in European domestic or public disposal systems. Return old or end-of-life equipment to the manufacturer for disposal at no charge to the user.

## 2.1.3 EMC compliance

### ▲ CAUTION

This equipment is not intended for use in residential environments and may not provide adequate protection to radio reception in such environments.

#### CE (EU)

The equipment meets the essential requirements of EMC Directive 2014/30/EU.

#### UKCA (UK)

The equipment meets the requirements of the Electromagnetic Compatibility Regulations 2016 (S.I. 2016/1091).

#### Canadian Radio Interference-Causing Equipment Regulation, ICES-003, Class A:

Supporting test records reside with the manufacturer.

This Class A digital apparatus meets all requirements of the Canadian Interference-Causing Equipment Regulations.

Cet appareil numérique de classe A répond à toutes les exigences de la réglementation canadienne sur les équipements provoquant des interférences.

#### FCC Part 15, Class "A" Limits

Supporting test records reside with the manufacturer. The device complies with Part 15 of the FCC Rules. Operation is subject to the following conditions:


1. The equipment may not cause harmful interference.
2. The equipment must accept any interference received, including interference that may cause undesired operation.

Changes or modifications to this equipment not expressly approved by the party responsible for compliance could void the user's authority to operate the equipment. This equipment has been tested and found to comply with the limits for a Class A digital device, pursuant to Part 15 of the FCC rules. These limits are designed to provide reasonable protection against harmful interference when the equipment is operated in a commercial environment. This equipment generates, uses and can radiate radio frequency energy and, if not installed and used in accordance with the instruction

manual, may cause harmful interference to radio communications. Operation of this equipment in a residential area is likely to cause harmful interference, in which case the user will be required to correct the interference at their expense. The following techniques can be used to reduce interference problems:

1. Disconnect the equipment from its power source to verify that it is or is not the source of the interference.
2. If the equipment is connected to the same outlet as the device experiencing interference, connect the equipment to a different outlet.
3. Move the equipment away from the device receiving the interference.
4. Reposition the receiving antenna for the device receiving the interference.
5. Try combinations of the above.

#### 2.1.4 Chemical and biological safety

<b>⚠ DANGER</b>	
	Chemical or biological hazards. If this instrument is used to monitor a treatment process and/or chemical feed system for which there are regulatory limits and monitoring requirements related to public health, public safety, food or beverage manufacture or processing, it is the responsibility of the user of this instrument to know and abide by any applicable regulation and to have sufficient and appropriate mechanisms in place for compliance with applicable regulations in the event of malfunction of the instrument.

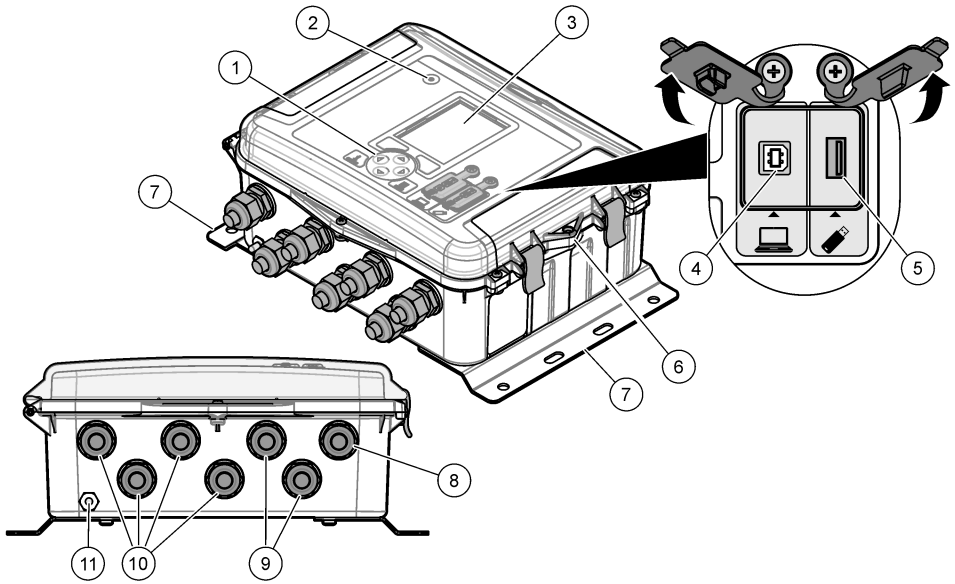
## 2.2 Product overview

The flow logger collects and analyzes water quality data from water quality sensors. The user can install the flow logger indoors or outdoors with protection from environmental conditions. There are two available models, a basic and advanced model. Refer to [Specifications](#) on page 3 for the available sensor options.

The user can configure the measurement parameters from the logger or from a connected computer. The user can also save a configured program to a USB memory stick and upload the program to the logger ([Figure 1](#)). Refer to [Figure 2](#) for a typical system configuration.

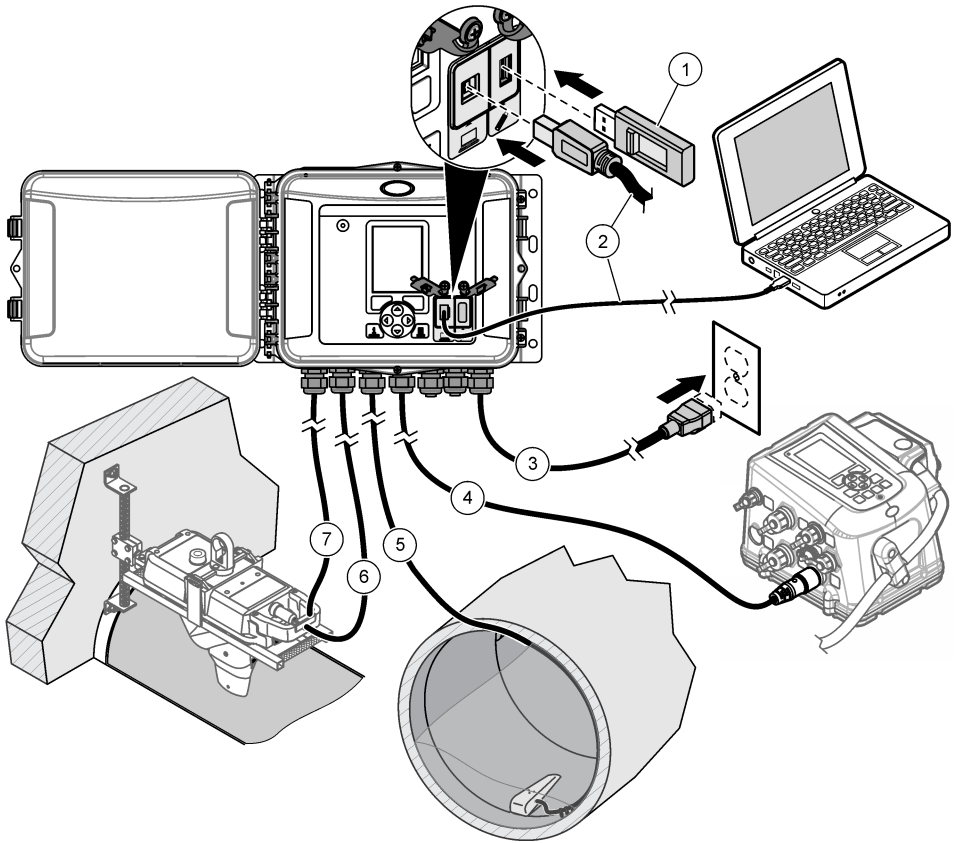


**Figure 1 Product overview**



1 Keypad	7 Mounting bracket (2x)
2 Indicator light	8 Cable strain relief—power
3 Display	9 Cable strain relief—relays (2x)
4 USB type B port for computer only	10 Cable strain relief—inputs or outputs (4x)
5 USB type A port for USB memory stick only	11 Air inlet
6 Hole, 6-mm (¼-inch), for user-supplied lock	

**Figure 2 Typical system configuration**



1 USB memory stick to USB A port	5 Flo-Tote 3 sensor cable
2 USB cable from PC to USB B port	6 Flo-Dar sensor cable
3 AC power cable	7 Surcharge velocity sensor (SVS) cable
4 Sampler auxiliary cable	

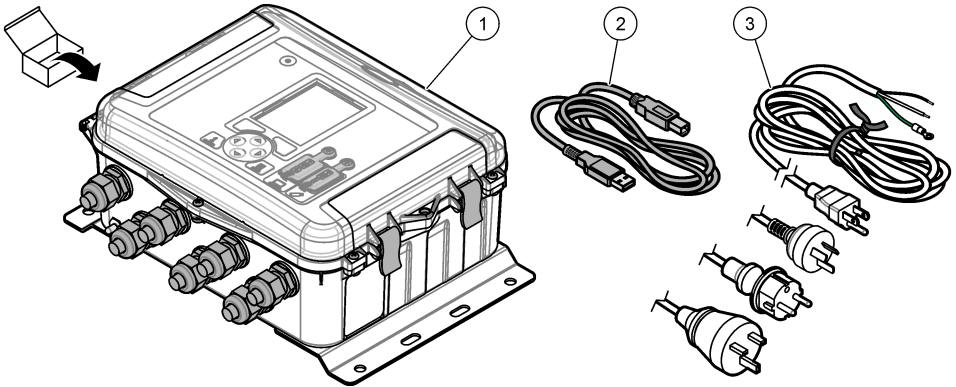
### **NOTICE**

Damage to the logger and PC can occur if the PC is connected to the incorrect port on the logger. Connect the PC only to the USB B port on the logger.

## 2.3 Product components

Make sure that all components have been received. Refer to [Figure 3](#). If any items are missing or damaged, contact the manufacturer or a sales representative immediately.

**Figure 3 Product components**



1 FL1500 flow logger	3 AC power cable with country-specific connector
2 Communications cable, USB A to B	

## Section 3 Installation

### ⚠ DANGER



Multiple hazards. Only qualified personnel must conduct the tasks described in this section of the document.

### 3.1 Installation guidelines

- Do not install the instrument in a location that receives direct exposure to sunlight, ultraviolet radiation (UV), severe weather or next to a heat source.
- Make sure that there is sufficient clearance around the instrument to make connections.
- Install the instrument in an environmental enclosure or protective cover when installed outdoors.

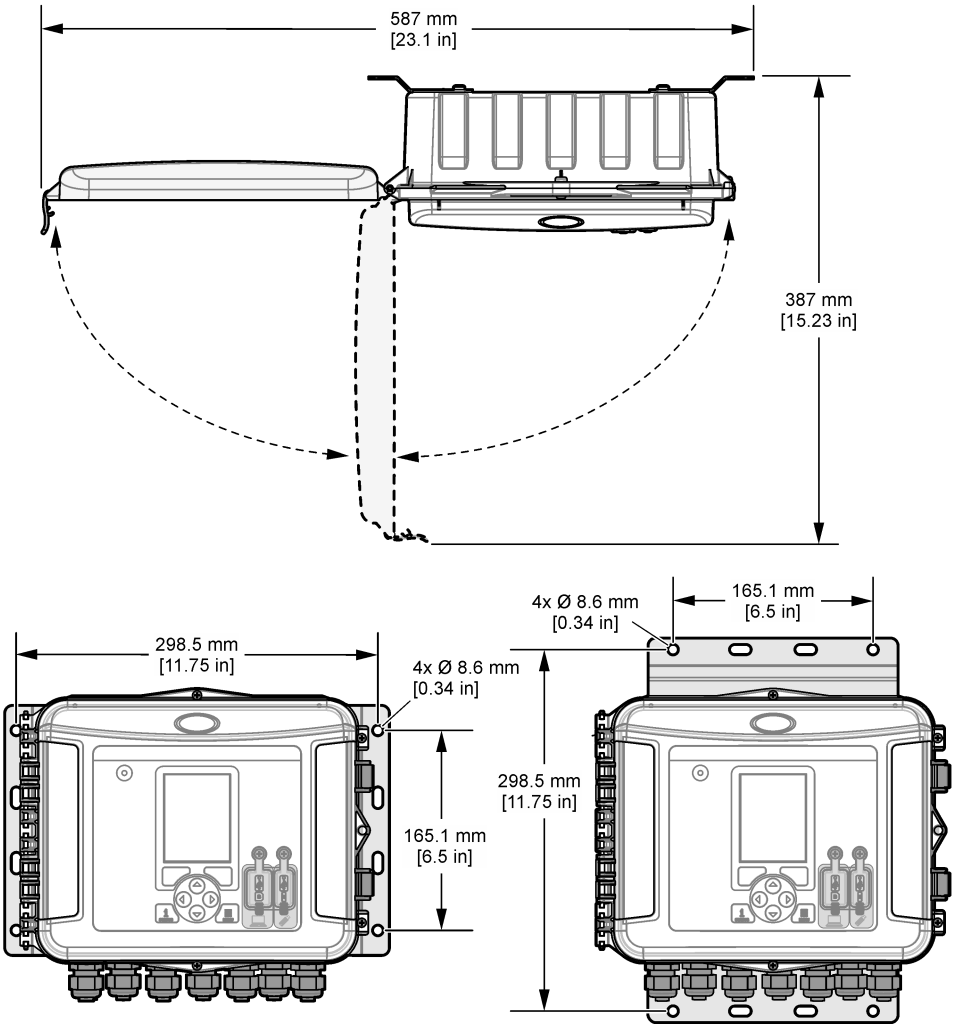
### 3.2 Mechanical installation

#### 3.2.1 Mounting

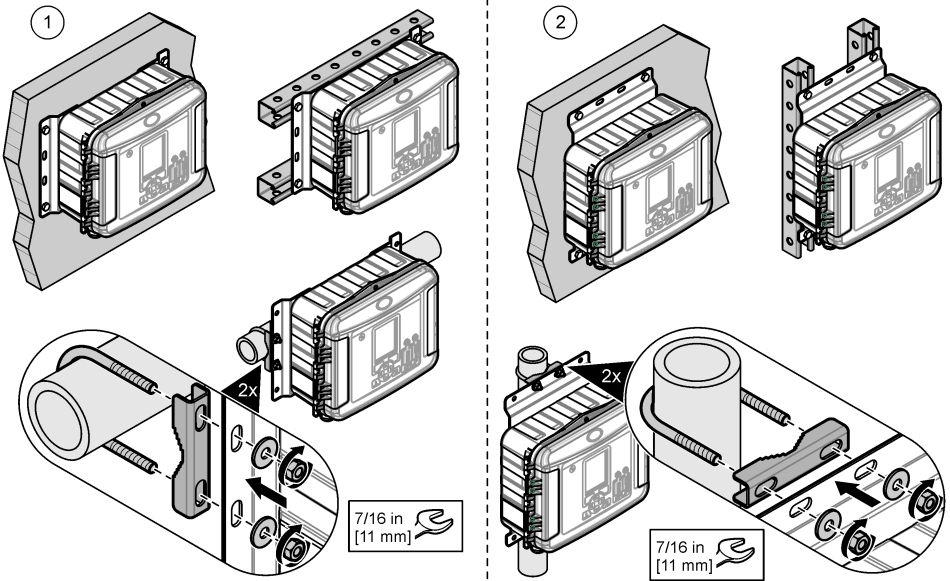
This instrument is rated for an altitude of 2000 m (6562 ft) maximum. Although the use of this equipment above the 2000 m altitude does not show any substantial safety concern, the manufacturer recommends that users with concerns contact technical support.

Attach the instrument to a wall, a rail or a pipe<sup>1</sup> with a diameter of 20 to 50 mm (0.75 to 2.0 inch). Refer to [Figure 4](#) and [Figure 5](#). Make sure that the wall mounting is able to hold 4 times the weight of the equipment.

**Figure 4 Mounting dimensions**

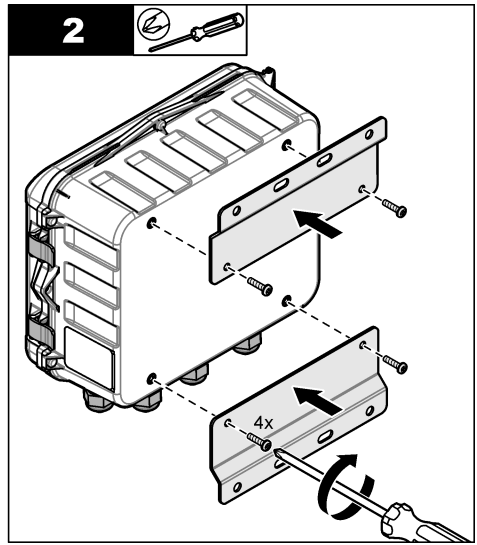
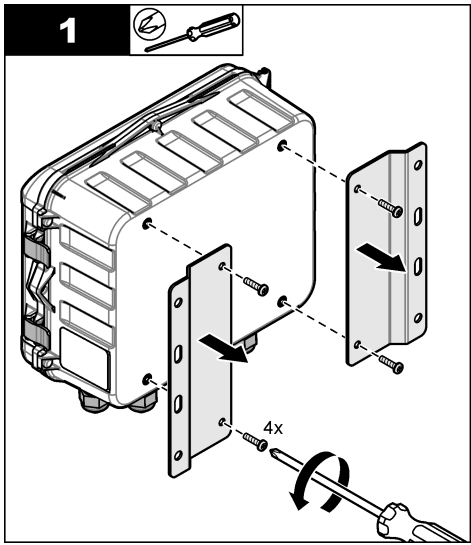


**Figure 5 Mounting options**



1 Horizontal wall, Unistrut or pipe <sup>1</sup> mount	2 Vertical wall, Unistrut or pipe <sup>1</sup> mount
--	--

The instrument is supplied with the brackets in the horizontal position. To change to the vertical position, refer to the illustrated steps that follow.



<sup>1</sup> Use the pipe mounting kit for pipe installations. Refer to [Replacement parts and accessories](#) on page 44.

### 3.3 Electrical installation

#### ⚠ DANGER



Electrocution hazard.

Always remove power to the instrument before making electrical connections.

Do not connect AC power directly to a DC powered instrument.

If this equipment is used outdoors or in potentially wet locations, a Ground Fault Circuit Interrupt (GFCI/GFI) device must be used for connecting the equipment to its main power source.

Protective Earth Ground (PE) connection is required.

Use only fittings that have the specified environmental enclosure rating. Obey the requirements in the Specifications section.

#### ⚠ WARNING



Electrical shock and/or fire hazards.

Install the instrument in accordance with local, regional and national regulations.

Externally connected equipment must have an applicable country safety standard assessment.

A local disconnect is needed for a conduit installation.

Make sure to identify the local disconnect clearly for the conduit installation.

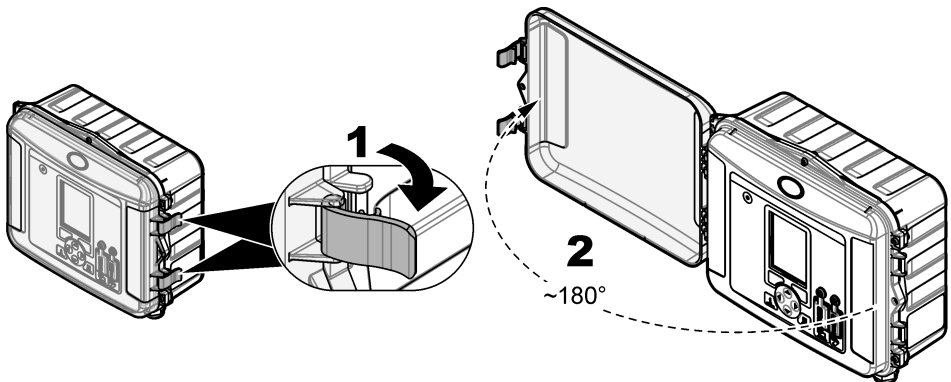


For a cord-connected instrument, make sure to install the instrument so that the cord can be disconnected easily from the supply socket.

#### 3.3.1 Open the cover

Open the cover to use the keypad and USB ports. Refer to [Figure 6](#).

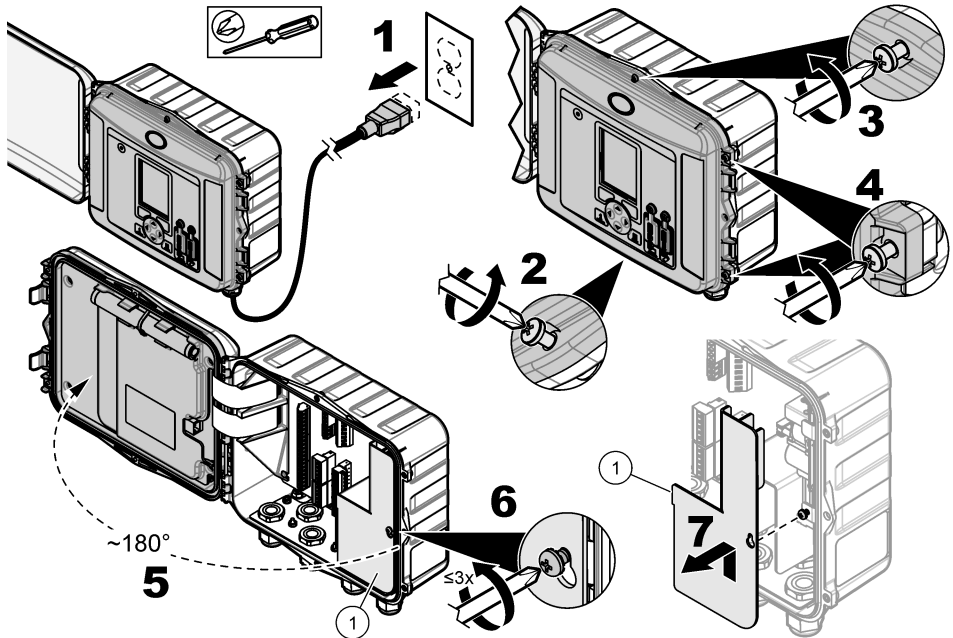
**Figure 6** Open the cover



### 3.3.2 Open the access door

Open the access door to access the wiring connections. Refer to [Figure 7](#).

Figure 7 Open the access door



1 High-voltage barrier—Remove only during power and relay installation.

### 3.3.3 Wiring information

#### ▲ DANGER



Electrocution hazard. In order to maintain the NEMA/IP environmental ratings of the enclosure, use only conduit fittings and cable glands rated for at least NEMA 4X/IP66 to route cables in to the instrument.

To keep the environmental rating and for safety:

- Make electrical cable connections through the cable strain reliefs. To supply power with conduit, replace a cable strain relief with a conduit hub. Seal the conduit with plumber's putty.
- Make sure that the diameter of the cables used is 4.3 to 11.4 mm (0.17 to 0.45 in.) so that the cable strain reliefs hold the cables securely when tightened. Use 24 to 12 AWG to connect to the terminals.
- Do not put more than one cable in a cable strain relief.
- Close all enclosure openings that are not used with cable strain reliefs or hardware (not conductive) approved by local electrical codes. Seal the cable strain reliefs that are not used with rubber cords (supplied) or cables.

Items to collect:

- Screwdriver, phillips
- Screwdriver, flat-head, small
- Wrench, 8.7 mm (11/32 in.)

### 3.3.4 Connect to power

The instrument can connect to an AC or a DC power source. When connected to AC power, an optional external backup battery can supply power if the AC power stops.

#### 3.3.4.1 Connect to AC power

#### ⚠ WARNING



Electrical shock and fire hazards. Make sure that the user-supplied power cord and non-locking plug meet the applicable country code requirements.

Connect to AC power with the manufacturer/customer-supplied AC power cord or with conduit. Make sure that a circuit breaker with sufficient electrical current capacity is installed in the power line.

#### Installation with a power cord

For installation with a power cord, make sure that the power cord is:

- Less than 3 m (10 ft) in length
- Rated for 300 VAC, 10 A minimum
- Rated for at least 70 °C (158 °F) and applicable to the installation environment
- If installed outdoors, the power cord jacket insulation is rated for outdoor use
- Not less than 0.82 mm<sup>2</sup> (18 AWG) with applicable insulation colors for local code requirements
- A power cable with a three-prong plug (with ground connection) that is applicable to the supply connection
- Connected through a cable gland (strain relief) that holds the power cable securely and seals the enclosure when tightened
- Does not have a locking type device on the plug
- Make sure that the power cord plug is near the instrument and is easily accessible

#### Installation with conduit

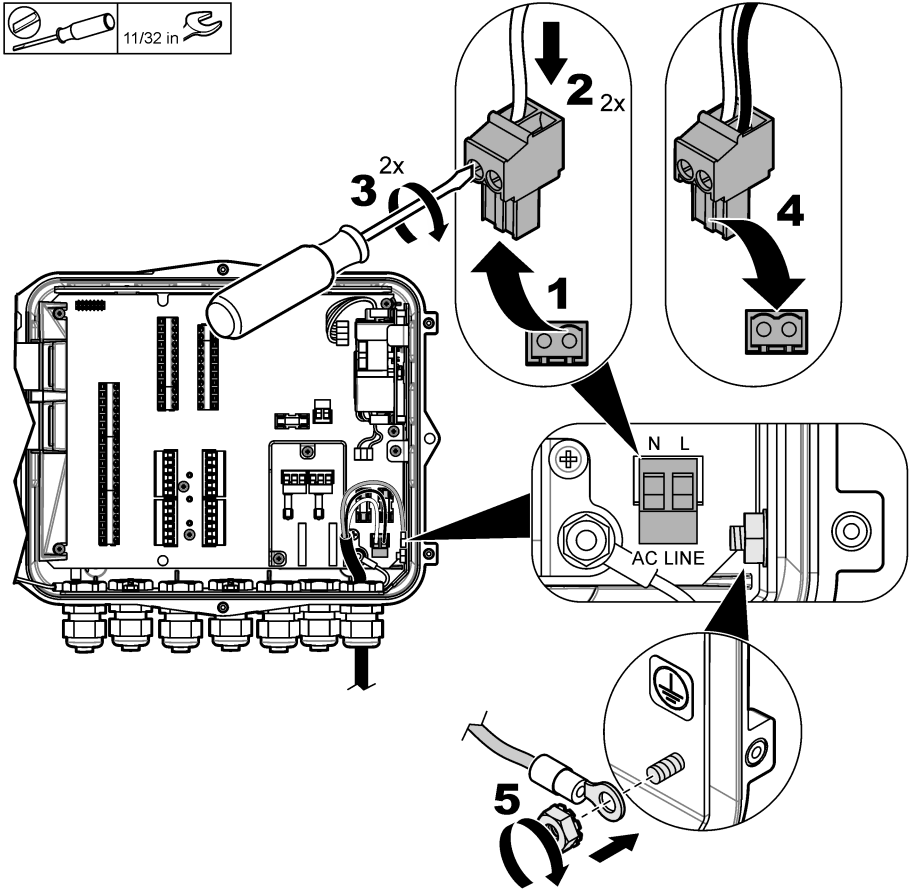
For installation with conduit:

- Install a local disconnect for the instrument within 3 m (10 ft) of the instrument. Put a label on the disconnect that identifies it as the main disconnect device for the instrument.
- Make sure that the power and safety ground service drops for the instrument are 0.82–3.3 mm<sup>2</sup> (18–12 AWG) (and the wire insulation is rated for 300 VAC or higher and 70 °C (158 °F) minimum).
- Connect equipment in accordance with local, state or national electrical codes.
- Connect the conduit through a conduit hub that holds the conduit securely and seals the enclosure when tightened.
- If metal conduit is used, make sure that the conduit hub is tightened so that the conduit hub connects the metal conduit to safety ground.
- Always install a sealing plug in conduit openings that are not used.

1. Open the access door. Refer to [Open the access door](#) on page 13.
2. Remove the high-voltage barrier.
3. Put the power cable through a strain relief fitting near the AC power connector.
4. Pull to remove the AC power connector.
5. Install each wire in the connector. Refer to [Figure 8](#) and [Table 1](#).
6. Push to install the connector in the instrument.
7. Connect the ground wire to the AC ground stud. Refer to [Figure 8](#).
8. Install the high-voltage barrier.
9. Tighten the cable strain relief or conduit hub.
10. Install the access door.



**Figure 8 AC power connections**




**Table 1 AC wiring information (AC models only)**

Connection	Color—North America	Color—EU, UK, AU
Hot (L)	Black	Brown
Neutral (N)	White	Blue
Protective earth ground (G)	Green	Green with yellow stripe

**3.3.4.1.1 Connect a backup battery**

**⚠ WARNING**



Explosion and fire hazard. Battery substitution is not permitted. Use only batteries that are supplied by the instrument manufacturer.

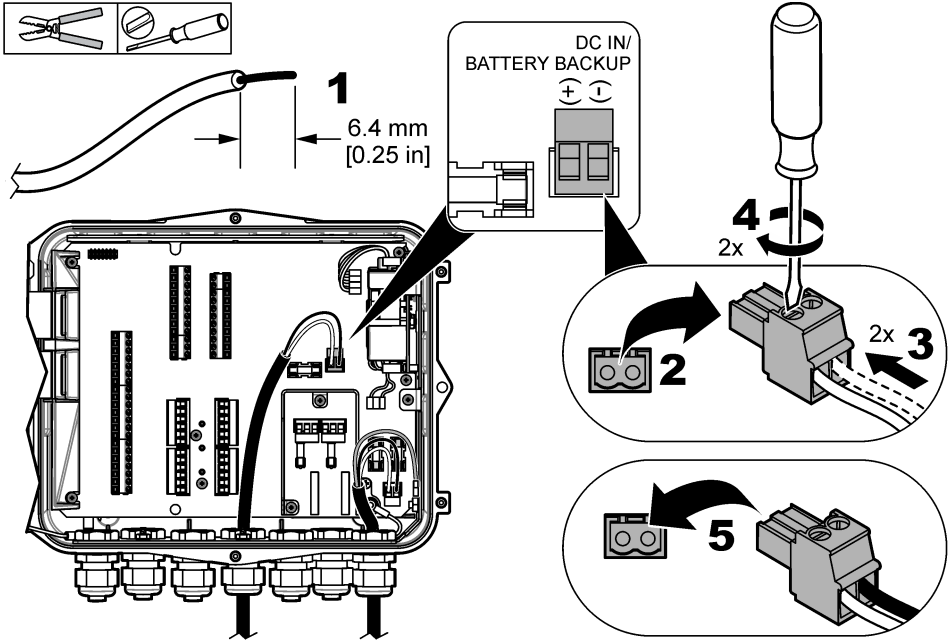
Connect a backup battery to AC units to keep a supply of power to the instrument during a power outage. Refer to [Accessories](#) on page 45. The external AC power charges the backup battery. If the AC power stops, the backup battery supplies power to the instrument.

For safety, obey all battery precautions and warnings. Discard the battery in accordance with local, regional and national regulations.

Install the battery near the instrument with the backup battery mounting bracket. Refer to the documentation supplied with the mounting bracket.

Use a backup battery 3-pin half cable to connect the backup battery to the instrument. Refer to [Figure 9](#) and [Table 2](#) to connect the backup battery to the DC terminal block.

**Figure 9 AC power with backup battery**



**Table 2 Backup battery wiring information (AC models only)**

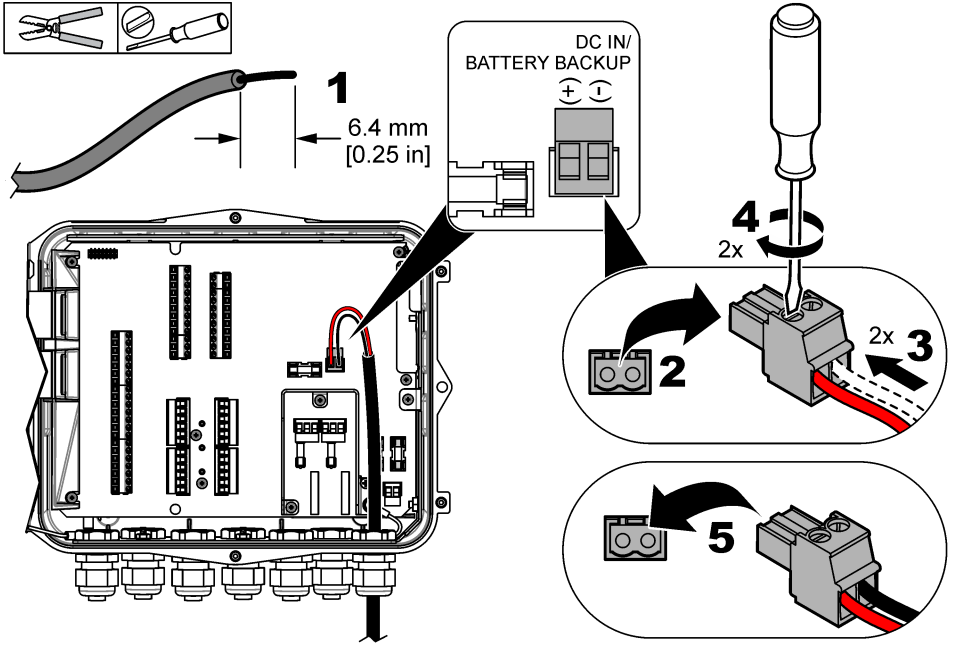
Connection	Color (cable 8307900)
12 VDC (+)	White
12 VDC return (-)	Black

### 3.3.4.2 Connect to DC power

Use a minimum 18 AWG wire to connect to DC power from a solar panel or customer-supplied DC power.

1. Open the access door. Refer to [Open the access door](#) on page 13.
2. Put the power cable through a strain relief fitting near the DC power connector.
3. Prepare the wires.
4. Pull to remove the DC power connector.
5. Install each wire in the connector. Refer to [Figure 10](#) and [Table 3](#).
6. Push to install the connector in the instrument.
7. Tighten the cable strain relief.
8. Install the access door.

**Figure 10 Connect to DC power**



**Table 3 DC wiring information (DC models only)**

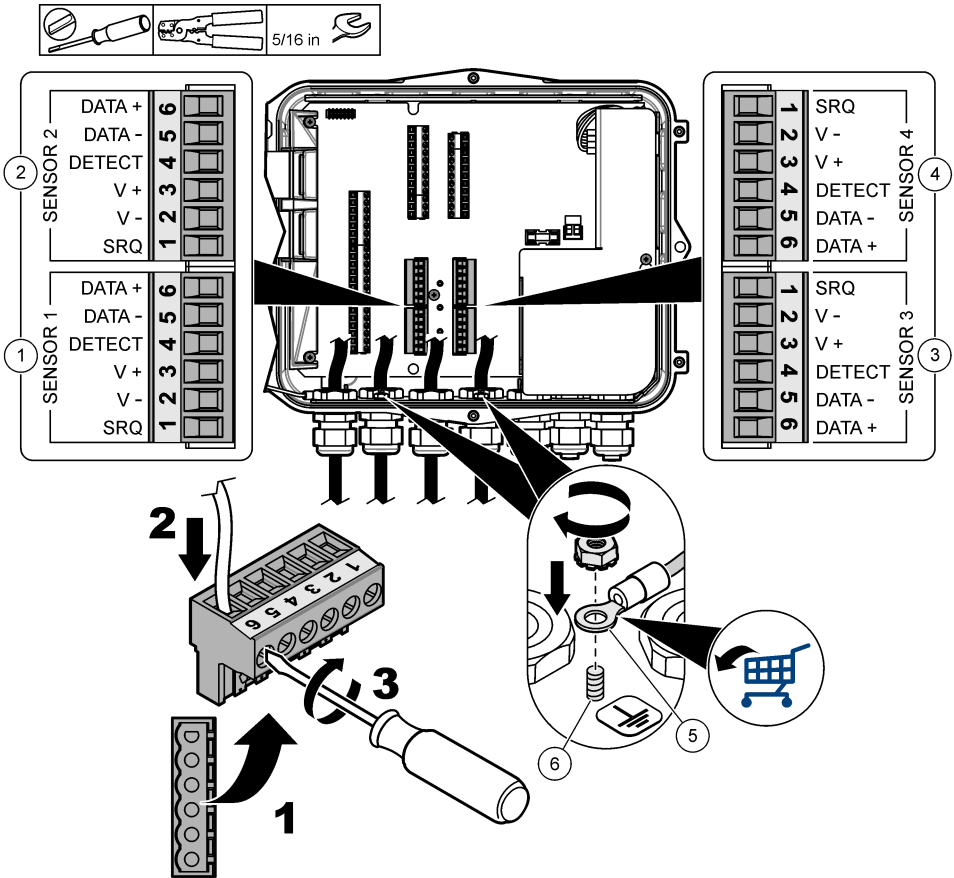
Connection	Typical color
12 VDC (+)	Red
12 VDC return (-)	Black

### 3.3.5 Connect to sensors

Connect one or more sensors to the instrument to monitor the measurement data and calibrate the sensor. Make sure to record the number of the sensor port where the sensors are connected. The user must select the sensor port number during configuration.

1. Remove the power to the instrument.
2. Open the access door. Refer to [Open the access door](#) on page 13.
3. Put the sensor cable through the strain relief fitting near the sensor connectors.
4. Pull to remove the sensor connector from an available sensor port. Refer to [Figure 11](#).  
*Note: Any of the sensor connectors can be used.*
5. Install each wire in the sensor connector as shown in [Figure 11](#) and [Table 4](#).
6. If the sensor has a shield wire, connect the shield wire to the ground studs with a user-supplied ring terminal.
7. Push to install the sensor connector in the instrument.
8. If the sensor has an air reference tube, refer to [Installation for Flo-Dar or Flo-Tote sensors](#) on page 19.
9. Record the number of the sensor port for use during configuration. Refer to [Figure 11](#).
10. Tighten the cable strain relief.
11. Install the access door.

**Figure 11 Sensor connections**



1 Sensor port 1	4 Sensor port 4 (advanced model only)
2 Sensor port 2	5 Ring terminal for shield wires
3 Sensor port 3 (advanced model only)	6 Ground stud for shield wires (2x)

**Table 4 Sensor wiring**

Signal	US9000	pHD <sup>2</sup>	BL9000 AV9000S	Flo-Dar <sup>3</sup>	SVS Flo-Tote 3	Junction box for US9000
6 DATA +	Yellow	Brown	White	White	White	White
5 DATA -	Gray	White	Black	Black	Black	Blue
4 DETECT	—	—	Green/white	Clear	Orange	—
3 V +	Brown	Blue	Red	Red	Red	Brown

<sup>2</sup> The pH sensor requires an adapter cable 8308000

<sup>3</sup> To connect to an intrinsically safe barrier, use the same wire colors that are used for the Flo-Dar.

**Table 4 Sensor wiring (continued)**

Signal	US9000	pHD <sup>2</sup>	BL9000 AV9000S	Flo-Dar <sup>3</sup>	SVS Flo-Tote 3	Junction box for US9000
2 V –	Blue	Black	Green	Green	Green	Black
1 SRQ	—	—	Blue	—	—	—

### 3.3.5.1 Installation for Flo-Dar or Flo-Tote sensors

Install the air reference tube and external desiccant to make sure that the pressure transducer in the sensor operates correctly. The desiccant cartridge prevents damage from moisture and debris. Moisture and debris can decrease the accuracy of the Flo-Dar and Flo-Tote sensors.

If the instrument is installed in a high-moisture environment, install a desiccant cartridge.

1. Remove the plug from one of the air reference ports. Refer to [Figure 12](#).

**Note:** Do not remove the plugs from the air reference ports that are not used.

2. Push the air reference tube from the sensor into the air reference port.

**Note:** If the sensor cable is pulled through a conduit, protect the wiring and air tube from damage and contamination.

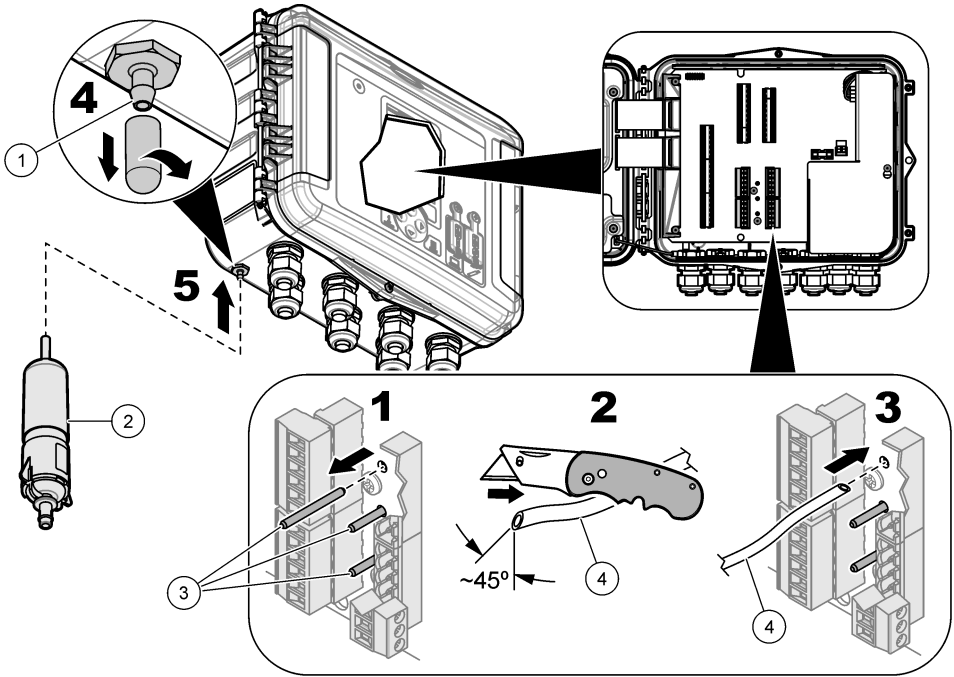
3. Install an external desiccant cartridge on the air inlet port. Refer to [Figure 12](#) and [Accessories](#) on page 45.

---

<sup>2</sup> The pH sensor requires an adapter cable 8308000

<sup>3</sup> To connect to an intrinsically safe barrier, use the same wire colors that are used for the Flo-Dar.

**Figure 12 Air reference tube and desiccant installation**



1 Air inlet	3 Plugs—remove only for air reference tubes
2 Desiccant cartridge	4 Air reference tube from sensor

### 3.3.6 Connect to optional devices

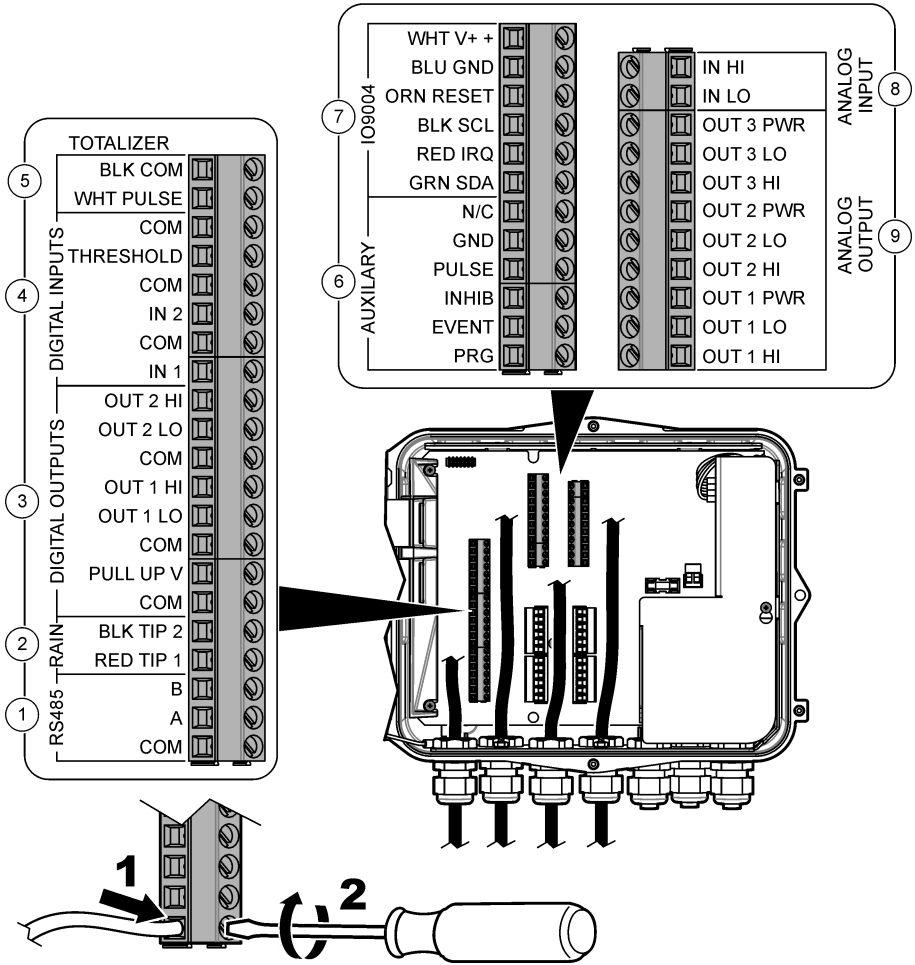
Refer to the steps that follow to connect the optional devices from the manufacturer.

1. Remove the power to the instrument.
2. Open the access door. Refer to [Open the access door](#) on page 13.
3. Put the cable through a strain relief fitting.
4. Install each wire in the terminal block. Refer to [Figure 13](#) and the wiring information for the applicable device:

Option	Description
<b>AS950 sampler</b>	Connect the sampler to the AUXILIARY terminal block with the sampler half cable. Refer to <a href="#">Table 5</a> .
<b>Rain gauge</b>	Connect the rain gauge to the RAIN terminal block. Refer to <a href="#">Table 6</a> .
<b>IO9004 module</b>	Connect the module to the IO9004 terminal block. Refer to <a href="#">Table 7</a> .
<b>Totalizer</b>	Connect the mechanical totalizer to the TOTALIZER terminal block. Refer to <a href="#">Table 8</a> .

5. Tighten the cable strain relief.
6. Install the access door.

**Figure 13 Optional device connections (advanced model shown)**



1 RS485	6 Sampler (AS950 sampler is recommended)
2 Rain gauge	7 IO9004 module
3 Digital outputs (2x)	8 Analog input
4 Digital inputs (2x)	9 Analog outputs (3x)
5 Totalizer, mechanical	

**Table 5 AS950 sampler wiring (auxiliary half cable 8528500/8528501)**

Connection	Color	Signal	Description
WHT NC	White	Not connected	—
BLU GND	Blue	Ground	Ground
ORG PULSE	Orange	Pulse in	This signal is a sample collection trigger from the flow logger (pulse or 4–20 mA) or a simple floating (dry) contact closure.

**Table 5 AS950 sampler wiring (auxiliary half cable 8528500/8528501) (continued)**

Connection	Color	Signal	Description
BLK INHIB	Black	Inhibit/Start	<b>Auxiliary control input</b> —Start a sampler after the sampling program on another sampler ends. As an alternative, start a sampler when a trigger condition occurs. For example, when a high or low pH condition occurs, the sampling program starts. <b>Liquid level input</b> —Start or continue the sampling program. A simple float level switch can supply input.
RED EVENT	Red	Sample event/Special output	This output goes from 0 to +12 VDC with respect to Terminal 1 after each sample cycle. Refer to the Mode setting of the hardware settings for the AUX I/O port. Refer to the AS950 operations documentation.
GRN PRG	Green	Program complete/Bottle	Typical state: open circuit. This output stays at ground level until the sampling program starts again. Use this output to start another sampler or to signal an operator or data logger at the end of the sampling program.
—	Bare wire	Shield (terminated in AS950 Sampler)	The shield is a connection to earth ground when AC power is supplied to a sampler to control RF emissions and susceptibility to RF emissions.

**Table 6 Rain gauge wiring information**

Connection	Color	Signal
BLK TIP 2	Black	Tip
RED TIP 1	Red	Tip
Shield ground	Bare wire	Shield

**Table 7 IO9004 module wiring information**

Connection	Color	Signal
WHT V++	White	Positive (+)
BLU GND	Blue	Ground
ORN RESET	Orange	Reset
BLK SCL	Black	Serial clock for communications bus
RED IRQ	Red	Interrupt request
GRN SDA	Green	Serial data for communications bus
Shield ground	Bare wire	Shield

**Table 8 Totalizer wiring information**

Connection	Color	Signal
BLK COM	Black	Common
WHT PULSE	White	Pulse



### 3.3.7 Connect to the relays

#### ⚠ DANGER



Electrocution hazard. Do not mix high and low voltage. Make sure that the relay connections are all high voltage AC or all low voltage AC.

#### ⚠ WARNING

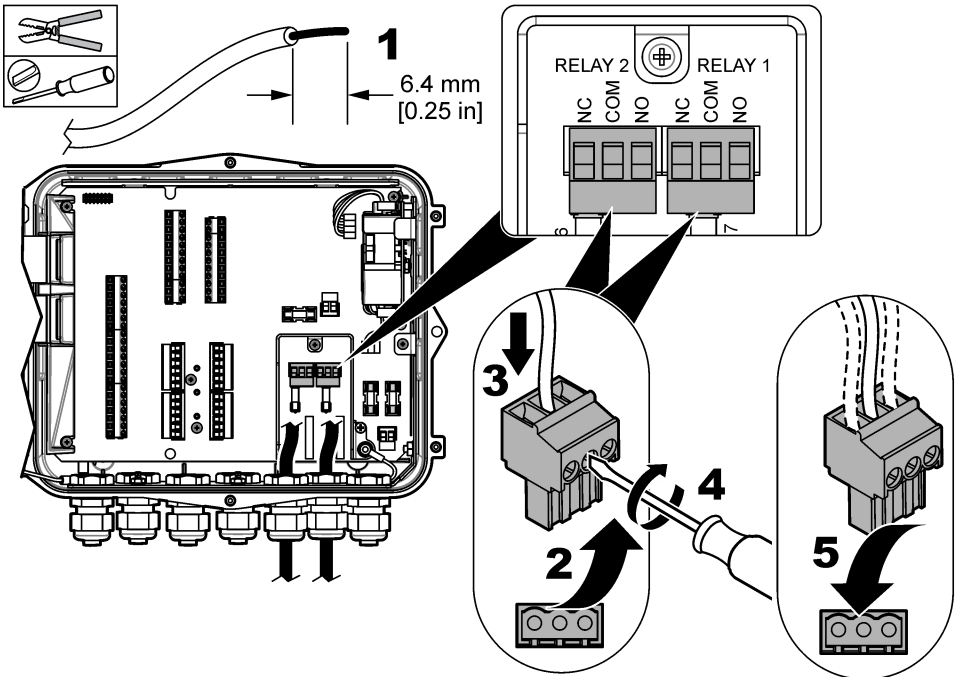


Fire hazard. Relay loads must be resistive. Always limit current to the relays with an external fuse or breaker. Obey the relay ratings in the Specifications section.

Use the relay connections to start or stop an external device such as an alarm. Use wire that is rated for 300 V. Use a minimum wire gauge of 18 AWG. Make sure to obey the relay connection requirements in [Specifications](#) on page 3. Make sure to have a second switch available to remove power from the relays locally if there is an emergency or for maintenance.

1. Remove the power to the instrument.
2. Open the access door. Refer to [Open the access door](#) on page 13.
3. Remove the high-voltage barrier.
4. Put the cable through a strain relief fitting near the relay connectors.
5. Strip the wires to 7 mm (0.275 inch).
6. Install each wire in the connector. Refer to [Figure 14](#) and [Table 9](#).
7. Install the high-voltage barrier.
8. Tighten the cable strain relief.
9. Install the access door.

**Figure 14 Relay connections**



**Table 9 Relay wiring information**

Connection	Signal
NO	Normally open
COM	Common
NC	Normally closed

### 3.3.8 Connect to the inputs and outputs

Connect a user-supplied device such as a PLC, recorder or third-party sensor to the analog input, analog output, digital input or digital output terminal blocks. Use a minimum wire gauge of 24 AWG. Make sure to obey the requirements for the input or output connection in [Specifications](#) on page 3.

1. Remove the power to the instrument.
2. Open the access door. Refer to [Open the access door](#) on page 13.
3. Put the cable through a strain relief fitting.
4. Install each wire in the terminal block. Refer to [Figure 13](#) on page 21 and the wiring information for the applicable connection:

Option	Description
<b>Analog input</b>	Connect a user-supplied device to the ANALOG INPUT terminal block. Refer to <a href="#">Table 10</a> . Do not connect the shield at both ends of the cable. Use of non-shielded cable can cause radio frequency emission or susceptibility levels that are higher than permitted.
<b>Analog output</b>	Connect a user-supplied device to the ANALOG OUTPUT terminal block. Refer to <a href="#">Table 11</a> . Do not connect to a device that has applied voltage. Do not use the analog outputs to supply power to a 2-wire (loop-powered) transmitter.

Option	Description
<b>Digital input</b>	Connect a user-supplied device to the DIGITAL INPUTS terminal block. Refer to <a href="#">Table 12</a> .
<b>Digital output</b>	<p>Connect a user-supplied device such as a remote alarm indicator, buzzer or PLC to the DIGITAL OUTPUTS terminal block. Refer to <a href="#">Table 13</a>. Do not use the digital outputs for process control functions. The digital output connections do not replace a PLC (programmable logic controller).</p> <p>The digital outputs are independent floating switches when the PULLUP V input and associated internal pull-up resistors are not used. The switches are normally open. The switches close when the user-selected alarm conditions occur.</p> <p>To use the optional PULLUP V input and the related internal 10 kΩ internal pull-up resistors, supply the applicable voltage to the PULLUP V and COM pins. Then, connect a jumper from the OUT # LO pin to the COM pin. The output signal logic is active low.</p>

- Tighten the cable strain relief.
- Install the access door.

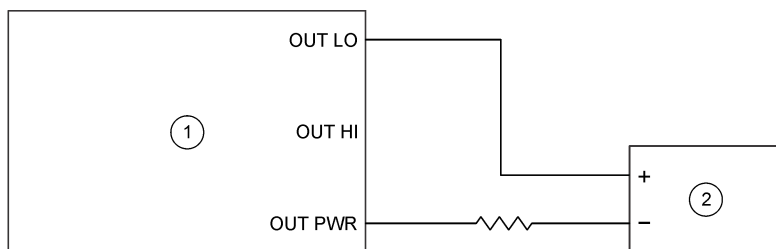
**Table 10 Analog input wiring information**

Connection	Signal
IN HI	Positive (+)
IN LO	Negative (-)

**Table 11 Analog output wiring information**

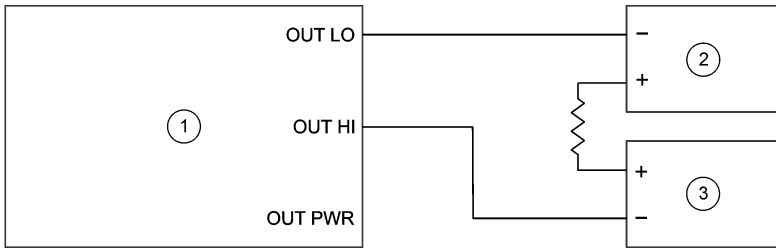
Connection	Signal
OUT LO	Negative (-)
OUT HI	Positive (+)
OUT PWR	Power

**Figure 15 FL1500-powered loop**



<b>1</b> Analog output	<b>2</b> External device
------------------------	--------------------------

**Figure 16 Externally-powered loop**



1 Analog output	2 External power supply	3 External device
-----------------	-------------------------	-------------------

**Table 12 Digital input wiring information**

Connection	Signal
COM	Negative for THRESHOLD
THRESHOLD	25 VDC maximum
COM	Negative (-)
IN 2	Positive (+)
COM	Negative (-)
IN 1	Positive (+)

**Table 13 Digital output wiring information**

Connection	Signal
OUT 2 HI	Positive (+)
OUT 2 LO	Negative (-)
COM	Common
OUT 1 HI	Positive (+)
OUT 1 LO	Negative (-)
COM	Common
PULLUP V	+25 VDC maximum (sets the logic high voltage)
COM	Common for PULLUP V

### 3.3.9 Connect to an RS485 network

Connect to an RS485 network for remote communication.

1. Remove the power to the instrument.
2. Open the access door. Refer to [Open the access door](#) on page 13.
3. Put the cable through a strain relief fitting.
4. Install each wire in the terminal block. Refer to [Figure 13](#) on page 21 and [Table 14](#).
5. Tighten the cable strain relief.
6. Install the access door.

**Table 14 RS485 wiring information**

Terminal	Signal
B	RS485 non-inverting signal B (+)
A	RS485 inverting signal A (-)
COM	RS485 common signal

## Section 4 Startup

### 4.1 Supply power

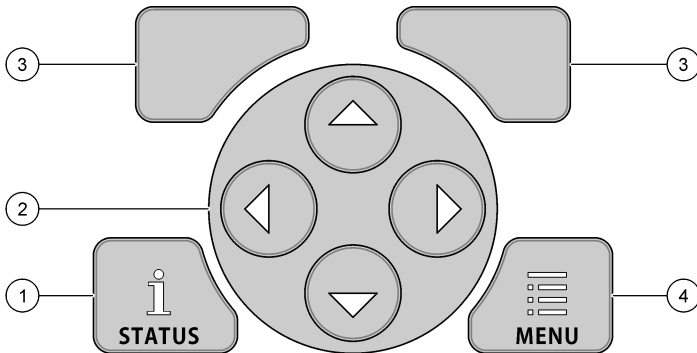
Connect the AC power plug to an electrical outlet to supply power to the instrument. If hard-wired with conduit, use the switch at the local disconnect to supply power. For DC-powered instruments, use the switch at the local disconnect to supply power.

## Section 5 User interface and navigation

### 5.1 Keypad description

Figure 17 shows the instrument keypad.

**Figure 17 Keypad**



1 STATUS key—Shows the instrument data, starts the slideshow	3 SOFT keys—Selects the option on the display
2 ARROW keys—Moves the cursor	4 MENU key—Goes to the main menu

#### Status screen

Push the STATUS key to see the instrument data screen. The instrument data screen shows the information that follows.

- Channels Logging—Shows the number of logged channels. Select Channels Logging to see the measurement data for the logged channels. Use the right arrow to scroll through the measurement data for all channels.
- Active Channel—Shows the active alarms. Select Active Channel to see the channel and system alarms.
- Totalizers—Shows the totalizer data for the configured totalizers. Select Totalizers to see the flow volume for the configured totalizers.
- Sensor Port—Shows the configured sensor ports. Select Sensor Port to see the configured sensors and inputs.

### 5.1.1 Show the data as a slideshow

The user can configure the display to show the instrument data screens in a slideshow format. When enabled, each screen shows for a user-selected time interval.

1. Push **MENU**.
2. Select General Settings.
3. Select Status Display Setup.
4. Select the options.

Option	Description
<b>Slideshow</b>	Enables or disables the slideshow. The enable option does not start the slideshow.
<b>Slide Selection</b>	Selects one or more types of data to include in the slideshow. Options: Datalog Channels, Alarms, Totalizer.
<b>Slide Duration</b>	Selects the time period that each screen shows. Options: 5 to 60 seconds.









5. Push **STATUS** to start the slideshow. Each data screen shows for the selected slide duration.
6. Select one of the options during the slideshow:

Option	Description
<b>Pause</b>	Stops the slideshow. Select Start to continue the slideshow.
<b>End</b>	Goes to the status screen. Push <b>STATUS</b> to start the slideshow again.

## 5.2 Main menu overview

Push the MENU key to see the main menu. [Table 15](#) shows the main menu options.





**Table 15 Main menu options**

Option	Description	Option	Description
 Programming	Selects the channels to log and the log intervals. Configures the channel and system alarms.	 Totalizers	Configures the settings for the mechanical (externally attached) and software totalizers.
 Sensor Setup	Configures the sensor and measurement parameters.	 Hardware Setup	Sets the options for the logger, sensors, totalizers, I/O type, sampler, and communications protocol.
 Calibration	Calibrates the installed sensors.	 Review Data	Shows the measurement data (the data log).
 Diagnostics	Shows the status screen, event log, alarm log, sensor data and internal I/O data. Has a test for the keypad and display.	 General settings	Shows the instrument details (e.g., serial number). Configures the general instrument and display settings. Erases data, sets security, exports/imports from a USB memory stick, restores defaults.

## 5.3 Status indicators

The indicator light shows the status of the instrument. Refer to [Table 16](#).

**Table 16 LED status indicators**

LED color	Description	
	Green	Flashes during normal operation.
	Red	Flashes when one or more alarms are active.
	Blue	Flashes when there is a communication problem with the IO9000 module or with a sensor with logged channels.
	Orange	Flashes when the internal memory battery is low. Contact factory service immediately.

## Section 6 Operation

### 6.1 Configuration options—Instrument or PC

#### **NOTICE**

Damage to the logger and PC can occur if the PC is connected to the incorrect port on the logger. Connect the PC only to the USB B port on the logger.

Use the keypad on the instrument or a PC with the applicable software to configure the instrument. This document contains instructions to configure the instrument from the keypad.

To use a PC for configuration, refer to the documentation for the applicable software to configure the instrument. When the configuration is complete, import the configuration file directly from the PC or from a USB memory stick. Refer to [Figure 1](#) on page 7 to connect a PC or USB memory stick to the instrument. Refer to [Import or export the instrument settings](#) on page 40 to import the configuration file.

### 6.2 Configure the general settings

Use the general settings menu to get instrument information, change the display settings, erase data, set security, export/import from a USB port, restore defaults.

1. Push **MENU**.
2. Select General Settings.
3. Select an option.

Push the **UP** and **DOWN** arrows to change the value. Push the **LEFT** and **RIGHT** arrows to move the cursor.

Option	Description
<b>About</b>	Shows the instrument description, serial number and firmware version.
<b>Status Display Setup (slideshow)</b>	Sets the display to show the measurement screens in a slideshow format. Refer to <a href="#">Show the data as a slideshow</a> on page 28.
<b>Date and Time</b>	Sets the time and date. Selects the format for the date and time. Options: dd/mm/yyyy 12h, dd/mm/yyyy 24h, mm/dd/yyyy 12h, mm/dd/yyyy 24h, yyyy/mm/dd 12h, yyyy/mm/dd 24h. Date, time zone and time are synchronized to UTC (coordinated universal time) with desktop software only. This synchronization is recommended for the most accurate datalog time records between the logger and the desktop. There is no automatic adjustment for daylight savings. The user must change the time manually.
<b>Time zone</b>	Sets the time zone (default: MST- US/Canada).

Option	Description
<b>Export/Import</b>	Sends or receives data or program files from the USB ports. Refer to <a href="#">Import or export the instrument settings</a> on page 40 for more information.
<b>Display</b>	Adjusts the brightness of the display (default: 50%).
<b>Security</b>	Enables security for password protection. When enabled, the user must enter the password to change the settings. When the display goes to sleep or the instrument power is set to off, the user must enter the password again. For password recovery, contact flow technical support.
<b>Language</b>	Sets the display language.
<b>Unit Preferences</b>	<b>Unit System</b> —Sets the system of measurement that shows on the display. After the unit system is selected, only the temperature units can change in the datalog programming menu. Options: US Customary or Metric. <b>Select Units</b> —Sets the individual measurement units that show on the display (e.g., level, velocity, flow, temperature, surface velocity, distance, minimum distance, maximum distance, surge level, rain, level raw and surge velocity).
<b>Clear Data</b>	Erases the selected log(s). Options: Data Log, Event Log, Alarm Log, Diagnostics Log, Sample Log and Clear All.
<b>Restore Factory Defaults</b>	Sets all the controller settings back to the factory defaults. Erases all data logs.

### 6.3 Set up the sensors—Setup Wizard

**Pre-requisites:** Install the sensor in the process and the sensor cable in the logger before this task is started.

The Setup Wizard is the easiest procedure to configure and calibrate the sensors. The Setup Wizard menu prompts the user for information about the sensor and the flow channel, then calibrates the sensor. As an alternative, the user can go into each menu item separately and enter the setup information.

1. Select Sensor Setup>Change port assignments.
2. Select the number of the sensor connector in the instrument where the sensor wires are installed.
3. Select the sensor name. Select OK.  
The sensor name shows next to the selected port number.
4. Select Setup Port [1] (sensor name).
5. Select Setup Wizard.
6. Select the options on each screen.

### 6.4 Flo-Dar setup

**Pre-requisites:** Install the sensor in the process and the sensor cable in the logger before this task is started.

Use the Sensor Setup menu to configure the Flo-Dar sensor for flow measurements. To use the factory-set options for the sensor, select Restore Defaults in the Sensor Setup menu.

1. Select Sensor Setup>Change port assignments.
2. Select the number of the sensor connector in the instrument where the sensor wires are installed.
3. Select the sensor name. Select OK.  
The sensor name shows next to the selected port number.
4. Select Setup Port [1] (sensor name).



5. Complete the options in the Basic Settings menu.

Option	Description
<b>Transducer Type</b>	Selects the sensor type. Options: Standard: 0 to 1.5 m (0 to 5 ft) or Long Range: 0 to 6.1 m (0 to 20 ft).
<b>Sensor Height</b>	Sets the height of the installed sensor. Enter the vertical distance from the bottom of the flow channel to the top of the sensor frame.
<b>Sediment</b>	Adjusts the level measurement for sediment in the flow channel. Enter the value of the vertical depth of the sediment in the flow channel. Options: 0.00 to 0.30 m (0.00 to 12.00 in.).
<b>Level Calibration</b>	Sets the instrument reading for level to the same value that is measured in the flow channel. Enter the vertical distance from the bottom of the flow channel to the top of the liquid.
<b>Velocity Method</b>	Sets the method for velocity measurements. Options: Direct Mean for circular flow channels or Velocity Multiplier for non-circular flow channels.
<b>Site Multiplier</b>	Adjusts the instrument reading for velocity to the same value that is measured by a portable instrument.
<b>SVS Port</b>	If an SVS sensor is used, select the sensor port on the logger where the SVS is installed.
<b>Reversed SVS Sensor</b>	If an SVS sensor is used and the Flo-Dar sensor is installed in the opposite direction from the flow, select Reversed SVS Sensor.

6. Complete the options in the Flow Settings menu.

Option	Description
<b>Device</b>	Selects the type of flow device. Options: Area velocity, flume, manning, nozzle, weir.
<b>Type</b>	Selects the shape or name of the device. Different options show for different devices.
<b>Dimensions</b>	Sets the dimensions of the device. Different options show for different devices, e.g. diameter, width, length, height, size, angle, slope, etc. Enter the values for the selected device.

## 6.5 Flo-Tote setup

**Pre-requisites:** Install the sensor in the process and the sensor cable in the logger before this task is started.

Use the Sensor Setup menu to configure the Flo-Tote sensor for flow measurements. To use the factory-set options for the sensor, select Restore Defaults in the Sensor Setup menu.

1. Select Sensor Setup>Change port assignments.
2. Select the number of the sensor connector in the instrument where the sensor wires are installed.
3. Select the sensor name. Select OK.  
The sensor name shows next to the selected port number.
4. Select Setup Port [1] (sensor name).
5. Complete the options in the Basic Settings menu.

Option	Description
<b>Level Calibration</b>	Sets the instrument reading for level to the same value that is measured in the flow channel. Enter the vertical distance from the bottom of the flow channel to the top of the liquid.
<b>Sensor Offset</b>	Sets the vertical distance from the bottom of the flow channel to the installed sensor location. Use the sensor offset option when the sensor is not installed at the bottom of the flow channel.

Option	Description
<b>Sediment</b>	Adjusts the level measurement for sediment in the flow channel. Enter the value of the vertical depth of the sediment in the flow channel. Options: 0.00 to 0.30 m (0.00 to 12.00 in.).
<b>Site Coefficient</b>	Adjusts the instrument reading for velocity to the same value that is measured by a portable instrument.

- Complete the options in the Flow Settings menu.

Option	Description
<b>Device</b>	Selects the type of flow device. Options: Area velocity, flume, manning, nozzle, weir.
<b>Type</b>	Selects the shape or name of the device. Different options show for different devices.
<b>Dimensions</b>	Sets the dimensions of the device. Different options show for different devices, e.g. diameter, width, length, height, size, angle, slope, etc. Enter the values for the selected device.

## 6.6 AV9000S setup

**Pre-requisites:** Install the sensor in the process and the sensor cable in the logger before this task is started.

Use the Sensor Setup menu to configure the AV9000S series sensors for flow measurements. To use the factory-set options for the sensor, select Restore Defaults in the Sensor Setup menu.

- Select Sensor Setup>Change port assignments.
- Select the number of the sensor connector in the instrument where the sensor wires are installed.
- Select the sensor name. Select OK.  
The sensor name shows next to the selected port number.
- Select Setup Port [1] (sensor name).
- Complete the options in the Basic Settings menu.

Option	Description
<b>Sensor Offset</b>	Sets the vertical distance from the bottom of the flow channel to the installed sensor location. Use the sensor offset option when the sensor is not installed at the bottom of the flow channel.
<b>Sediment</b>	Adjusts the level measurement for sediment in the flow channel. Enter the value of the vertical depth of the sediment in the flow channel. Options: 0.00 to 0.30 m (0.00 to 12.00 in.).
<b>Level Calibration</b>	Sets the instrument reading for level to the same value that is measured in the flow channel. Enter the vertical distance from the bottom of the flow channel to the top of the liquid.
<b>Sensor Direction</b>	Selects the installation direction of the sensor. Select Reversed if the sensor is installed in the reverse direction. Options: Normal (default) or Reversed.

- Complete the options in the Flow Settings menu.

Option	Description
<b>Device</b>	Selects the type of flow device. Options: Area velocity, flume, manning, nozzle, weir.
<b>Type</b>	Selects the shape or name of the device. Different options show for different devices.
<b>Dimensions</b>	Sets the dimensions of the device. Different options show for different devices, e.g. diameter, width, length, height, size, angle, slope, etc. Enter the values for the selected device.

## 6.7 US9000 setup

**Pre-requisites:** Install the sensor in the process and the sensor cable in the logger before this task is started.

Use the Sensor Setup menu to configure the US9000 series sensors for flow measurements. To use the factory-set options for the sensor, select Restore Defaults in the Sensor Setup menu.

1. Select Sensor Setup>Change port assignments.
2. Select the number of the sensor connector in the instrument where the sensor wires are installed.
3. Select the sensor name. Select OK.  
The sensor name shows next to the selected port number.
4. Select Setup Port [1] (sensor name).
5. Complete the options in the Basic Settings menu.

Option	Description
<b>Sensor Type</b>	Selects the sensor type. Options: Downlooking or In-Pipe.
<b>Sediment</b>	Adjusts the level measurement for sediment in the flow channel. Enter the value of the vertical depth of the sediment in the flow channel. Options: 0.00 to 0.30 m (0.00 to 12.00 in.).
<b>Level Offset</b>	Sets the instrument reading for level to the same value that is measured in the flow channel. Enter the difference between the measured level and the actual level. Options: -0.61 to 0.61 m (-24.00 to 24.00 in.).

6. Complete the options in the Flow Settings menu.

Option	Description
<b>Device</b>	Selects the type of flow device. Options: Area velocity, flume, manning, nozzle, weir.
<b>Type</b>	Selects the shape or name of the device. Different options show for different devices.
<b>Dimensions</b>	Sets the dimensions of the device. Different options show for different devices, e.g. diameter, width, length, height, size, angle, slope, etc. Enter the values for the selected device.

## 6.8 BL9000 bubbler setup

**Pre-requisites:** Install the sensor in the process and the sensor cable in the logger before this task is started.

Use the Sensor Setup menu to configure the bubbler for level and flow measurements. For an explanation of the setup options, refer to the user manual for the bubbler. To use the factory-set options for the sensor, select Restore Defaults in the Sensor Setup menu.

1. Select Sensor Setup>Change port assignments.
2. Select the number of the sensor connector in the instrument where the sensor wires are installed.
3. Select the sensor name. Select OK.  
The sensor name shows next to the selected port number.
4. Select Setup Port [1] (sensor name).
5. Complete the options in the Basic Settings menu.

Option	Description
<b>Bubble Rate</b>	Changes the rate that bubbles come out of the bubbler line. Options: 1 to 5. Increase or decrease the bubble rate number until the bubble rate is approximately one bubble per second.
<b>Auto Purge</b>	Enables or disables the automatic purge option that cleans the bubbler line at selected intervals. When enabled, set the interval when each purge will occur. <b>Note:</b> To clean the bubbler line between intervals, use the manual purge option. Use manual purge also to validate that bubbles come from the bubbler line outlet.
<b>Sediment</b>	Adjusts the cross-section (area) of the flow channel for sediment in the flow channel when area is used in the flow calculation. Enter the value of the vertical depth of the sediment in the flow channel. Options: 0.00 to 25.40 m (0.00 to 999.99 in.).

Option	Description
<b>Level Adjust</b>	Sets the level value to the current head (the level that contributes to flow) in the channel. Use the level adjust option for weir installations when the bubbler line outlet is in the water. The level adjust value is the vertical distance from the zero reference point to the water level. Level adjust values are positive when the water level is above the zero reference point, or negative when the water level is below the zero reference point. In a circular pipe, the level that contributes to flow is the distance from the surface of the water to the invert (bottom) of the pipe. In a flume the level that contributes to flow is the distance from the surface of the water to the floor of the flume. Enter the vertical distance (0 to 999.99 in.) from the zero reference point to the water level above the zero reference point. <b>Note:</b> When the user enters a value for level adjust, the control instrument erases the sensor offset value.
<b>Sensor Offset</b>	Adjusts the level measurement for applications where the bubbler line outlet is above or below the zero reference point. Use the sensor offset option for weir installations where the bubbler line outlet is not currently in the water or in non-weir applications where the bubbler line outlet is above or below the zero reference point of the channel. The sensor offset value is the vertical distance from the bubbler line outlet to the zero reference point. Enter the vertical distance (0 to 999.99 in.) from the bubbler line outlet to the zero reference point. <b>Note:</b> When the user enters a value for sensor offset, the control instrument erases the level adjust value.

6. Complete the options in the Flow Settings menu.

Option	Description
<b>Device</b>	Selects the type of flow device. Options: Area velocity, flume, manning, nozzle, weir.
<b>Type</b>	Selects the shape or name of the device. Different options show for different devices.
<b>Dimensions</b>	Sets the dimensions of the device. Different options show for different devices, e.g. diameter, width, length, height, size, angle, slope, etc. Enter the values for the selected device.

## 6.9 pH sensor setup

**Pre-requisites:** Install the sensor in the process and the sensor cable in the logger before this task is started.

Use the Sensor Setup menu to configure the pH sensor. To use the factory-set options for the sensor, select Restore Defaults in the Sensor Setup menu.

1. Select Sensor Setup>Change port assignments.
2. Select the number of the sensor connector in the instrument where the sensor wires are installed.
3. Select the sensor name. Select OK.  
The sensor name shows next to the selected port number.
4. Select Setup Port [1] (sensor name).
5. Complete the options in the Basic Settings menu.

Option	Description
<b>AC Frequency</b>	Selects the power line frequency to get the best noise rejection. Options: 50 or 60 Hz (default).

## 6.10 Calibrate the sensors

Calibrate the sensors during sensor setup and at regular intervals. Make sure that the sensor is installed in the process before this task is started.

1. Push **MENU** and select Calibration.
2. Select the sensor to calibrate.
3. Obey the screen prompts to select the necessary values.

4. Wait for the screen to show Calibration Complete with a summary of the calibration data.  
*Note: If the calibration fails, make sure that the parameters in the Sensor Setup menu are correct.*
5. Select Finish. The Verify screen shows.
6. Select Yes to take a measurement to verify the calibration.
7. Examine the measurement data to determine if the measurement is correct.

## 6.11 Configure data logging

### NOTICE

All data and alarm logs for all channels are erased in the logger when channels are added to or removed from a program. Make sure to download the data from the logger to a safe location first, then change the program.

Use the Programming menu to set the channels to record in the data log. A channel can be a reading from an attached sensor (e.g., level, flow, temperature), the battery voltage from a backup battery or a statistical value based on a sensor reading. Data logging starts only when a channel is selected.

1. Push **MENU**.
2. Select Programming>Datalog Programming.
3. Select Channels Logging.
4. Select the sensor or logger.
5. Select a maximum of 16 channels.

*Note: The port number where the sensor connects to the instrument shows in the sensor channel name. For example, Velocity 2 is the velocity channel name for the sensor that connects to sensor port 2. An IO number that follows a channel name identifies the analog inputs of the optional I/O module.*

6. Select Save.
7. Select Back>Logging Intervals>sensor or logger to set the logging interval.
8. Select the primary and secondary logging interval. The primary logging interval operates during normal operation. The secondary logging interval operates during alarm conditions.

*Note: The primary and secondary logging intervals operate for all channels of a sensor or the logger. A logging interval for an individual channel is not possible.*

## 6.12 Configure the alarms

### NOTICE

All alarm logs are erased when programmed alarms are deleted. Make sure to save the settings and data first, then change the program.

Alarms are available for the system and for the channels. The channel alarms are setpoint alarms for the recorded measurements (channels), such as the pH, level and power supply voltage. The system alarms are for sensor timeout errors, power issues or digital inputs (digital inputs are available on advanced model only). The user can set a maximum of 32 alarms. Make sure to configure the data logging before this task is started.

1. Push **MENU**.
2. Select Programming>Alarm Programming.
3. Add a channel alarm as follows:
  - a. Select Channel Alarms>Add New Alarm.
  - b. Select the channel, then push **Next**

*Note: The port number where the sensor connects to the instrument shows in the sensor channel name. For example, Velocity 2 is the velocity channel name for the sensor that connects to sensor port 2. An IO number that follows a channel name identifies the analog inputs of the optional I/O module.*

c. Select the type of alarm.

Option	Description
<b>Low/Low</b>	Sets the lowest alarm setpoint and the deadband for the lowest alarm setpoint.
<b>Low</b>	Sets the low alarm setpoint and the deadband for the low alarm setpoint.
<b>High</b>	Sets the high alarm setpoint and the deadband for the high alarm setpoint. Refer to <a href="#">Figure 18</a> for an example of a high alarm setpoint.
<b>High/High</b>	Sets the highest alarm setpoint and the deadband for the highest alarm setpoint.
<b>Rate of Change</b>	Sets the alarm setpoint, deadband for the setpoint and the amount of time for the rate of change (rain only).

d. Enter the value when the alarm starts (trigger value).

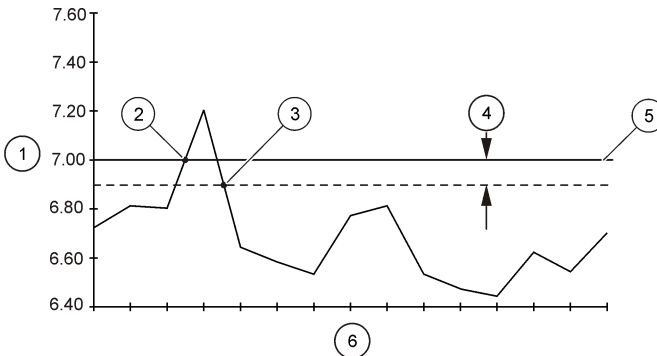
e. Enter the deadband value. Refer to [Figure 18](#).

4. Select an option, then push **OK**.

*Note: More options show when the optional IO9004 module is connected to the IO9004 terminal port.*

Option	Description
<b>Log Only</b>	Records the alarm in the alarm log.
<b>Switch Log Interval</b>	Changes the data logging interval to the secondary logging interval during an active alarm. Refer to <a href="#">Configure data logging</a> on page 35.

**Figure 18 High setpoint example**



1 Measurement value	3 Setpoint trigger off	5 Setpoint value
2 Setpoint trigger on	4 Deadband	6 Time

5. Add a system alarm as follows:

- Select System Alarms>Add New Alarm>[Select System Alarm].
- Select the type of alarm.
- Select **Next**.

- d. Select an option, then select OK.

Option	Description
<b>Log Only</b>	Sets the alarm to be recorded to the alarm log when the alarm occurs.
<b>Switch Log Interval</b>	Sets the data logging interval to change to the secondary logging interval while the alarm is active.
<b>Trigger Sampler</b>	Starts an attached sampler program.

**Note:** To make sure that the red LED flashes for a fault condition of a logged channel, configure the alarms for normal ranges.

## 6.13 Configure the software totalizer

**Pre-requisites:** Program the instrument to record one or more flow channels in the data log.

The software totalizer counts the total flow volume for one or more flow channels. The user can set the flow volume to zero if necessary.

1. Push **MENU**.
2. Select Totalizers>Software.
3. Select the sensor with the applicable flow channel.
4. Select Settings.
5. Select the options:

Option	Description
<b>Enable/Disable</b>	Starts or stops the totalizer.
<b>Unit</b>	Sets the totalizer flow units. Options: gallons (default), liters, acre feet, cubic feet, cubic meters.
<b>Scaling</b>	Sets a multiplier for high or low flow rates. For example, if the totalizer flow shows (x1000) 465 gallons, the actual flow volume is 465,000 gallons. Options: x1 (default), x10, x100, x1000, x10000, x100000, x1000000, x0.1

6. To set the totalizer to zero for a configured flow channel, select Reset.

**Note:** If channels are added to or removed from a program, the instrument erases all data from all channels and totalizers (resettable and non-resettable). Make sure to download the data from the logger to a safe location before the program is changed.

## 6.14 Configure the mechanical totalizer

**Pre-requisites:** Connect the mechanical totalizer to the instrument. Program the instrument to record a flow channel in the data log.

The mechanical totalizer is an external device that counts the total flow volume for one flow channel. The user cannot set the mechanical totalizer to zero after operation starts.

1. Push **MENU**.
2. Select Totalizers>Mechanical.
3. Select the options:

Option	Description
<b>Enable/Disable</b>	Starts or stops the totalizer.
<b>Unit</b>	Sets the totalizer flow units. Options: gallons (default), liters, acre feet, cubic feet, cubic meters.
<b>Source</b>	Selects the sensor or input with the applicable flow channel.

Option	Description
<b>Volume Per Pulse</b>	Sets the flow volume for each pulse signal from the flow channel, for example 100 gallons. Set the flow volume to a large number for high flow volumes and a small number for low flow volumes.
<b>Pulse Width</b>	Sets the time (in ms) that each pulse signal operates from the flow channel.
<b>Pulse Delay</b>	Sets the time (in ms) between each pulse signal from the flow channel.

4. Calculate the total flow for a time period.
  - a. Record the number on the mechanical totalizer at the start of the time period.
  - b. Record the number on the mechanical totalizer at the end of the time period.
  - c. Subtract the number at the start of the time period from the number at the end of the time period to get the flow volume in pulses.
  - d. Multiply the flow volume in pulses by the volume per pulse to get the flow volume in the selected flow units.

## 6.15 Configure the inputs and outputs

Use the I/O menu to configure the inputs, outputs and relays in the instrument or in the external IO9004 module.

1. Push MENU.
2. Select Hardware Setup>I/O.
3. Select an option:

Option	Description
<b>Internal I/O</b>	Configures the inputs, outputs and relays in the instrument.
<b>External I/O</b>	Configures the inputs, outputs and relays in a connected IO9004 module. Select External I/O>IO9004>Enable.

4. Select the input or output option:

Option	Description
<b>Analog inputs</b>	Enables or disables the analog inputs. Selects the type of measurement, the 0–20 mA or 4–20 mA scale and the values for the minimum and maximum signal. Calibrates the minimum and maximum signal (optional).
<b>Analog outputs</b>	Enables or disables the analog outputs. Selects the measurement channel, the 0–20 mA or 4–20 mA scale and the values for the minimum and maximum signal. Sets the power mode to internal or external. Sets a transfer value for use during maintenance tasks. Calibrates the minimum and maximum signal (optional).
<b>AC relays</b>	Enables or disables the relays.
<b>Digital outputs</b>	Enables or disables the digital outputs.
<b>Digital inputs</b>	Enables or disables the digital inputs. Selects the trigger value options: low to high or high to low. Sets the voltage threshold to internal or external.

## 6.16 Configure flow pacing for connected samplers

Use flow pacing to set up an attached automatic sampler to collect samples at specified flow intervals. Make sure that the wires from the sampler cable connect to the auxiliary port in the logger.



**Note:** The sampler can also collect a sample during alarm conditions if the Trigger Sampler action is set for a channel alarm.

1. Push **MENU**.
2. Select Hardware Setup>Sampler.
3. Select the options.

Option	Description
<b>Source</b>	Selects the flow channel to measure the flow for sampler pacing.
<b>Interval</b>	Sets the volume interval that sends a flow pulse to the sampler. For example, a sampler can collect a sample for each 100 gallons of flow.
<b>Unit</b>	Selects the flow units. Options: gal (gallons, default), ltr (liters), af (acre feet), ft <sup>3</sup> (cubic feet), m <sup>3</sup> (cubic meters).

## 6.17 Configure network communications

Configure the instrument for network communications when an RS485 cable is installed in the instrument.

1. Push **MENU**.
2. Select Hardware Setup>Communication>RS485.
3. Select an option to change the address, baud rate or parity. The default baud rate is 115200 and the default parity is none.

## 6.18 Data management

### 6.18.1 View data

View the measurement data on the display screen or on a PC with the applicable software. This document contains instructions to view the measurement data from the instrument.

1. Push **MENU**.
2. Select Review Data>Measurement Data.
3. Select the sensor.
4. Select the measurement channel. A graph of the data for the measurement channel shows on the display.
5. Select an option.

Option	Description
<b>View Type</b>	Changes the view to graph or tabular. Use the arrow keys to move to other data views.
<b>Zoom</b>	Sets the data window to one week, one day or one hour.
<b>Jump to newest</b>	Goes to the most recent measurement data.
<b>Jump to oldest</b>	Goes to the oldest measurement data.
<b>Jump to Date &amp; Time</b>	Selects the date and time of the measurement data to be viewed.

### 6.18.2 Save data to a USB stick

The user can save data to a USB 2.0 memory stick and view the data on a PC with FSDATA Desktop.

1. Push **MENU**.
2. Select General Settings>Import/Export.
3. Put a USB memory stick into the USB port and select Next.

4. Select Export Data. The instrument sends the data to the USB memory stick. All files are in FSDATA Destop format.
5. Select OK and remove the USB memory stick.  
The instrument makes an FL1500 folder on the USB memory stick. The data files go in a new subfolder each time the instrument sends data.

### 6.18.3 Import or export the instrument settings

#### NOTICE

When the import option is used, all the user settings in the instrument are replaced with the imported settings. The data in the log files is erased.

The user can save the configured instrument settings to a USB 2.0 memory stick and import the settings into a different instrument. The instrument makes 10 folders on the USB stick for each settings file. When a settings file is in a folder, the folder shows "Used".

1. Push **MENU**.
2. Select General Settings>Import/Export.
3. Put a USB 2.0 memory stick into the USB port and select Next.
4. Select an option.

Option	Description
<b>Export Settings</b>	Saves the settings to the USB memory stick or PC in a FL1500/Settings/Settings[1–10] folder. There are 10 possible Settings folders. Select a folder that shows "Free".
<b>Import Settings</b>	Imports the settings from the USB memory stick or PC. If there is more than one settings folder on the USB memory stick or PC, select the applicable folder.

## Section 7 Maintenance

### ⚠ DANGER



Multiple hazards. Only qualified personnel must conduct the tasks described in this section of the document.

### 7.1 Maintenance schedule

Table 17 shows the recommended schedule of maintenance tasks. Facility requirements and operating conditions may increase the frequency of some tasks.

**Table 17 Maintenance schedule**

Task	As necessary
<a href="#">Clean the instrument</a> on page 40	X
<a href="#">Replace the fuses</a> on page 41	X
<a href="#">Replace the internal desiccant</a> on page 42.	X
Replace the external desiccant cartridge (if applicable). Refer to <a href="#">Installation for Flo-Dar or Flo-Tote sensors</a> on page 19	X

### 7.2 Clean the instrument

#### NOTICE

Never use cleaning agents such as turpentine, acetone or similar products to clean the instrument including the display and accessories.

Clean the exterior of the instrument with a moist cloth and a mild soap solution.

## 7.3 Replace the fuses

### ⚠ DANGER



Electrocution hazard. Remove all power from the instrument and relay connections before this maintenance task is started.

### ⚠ DANGER

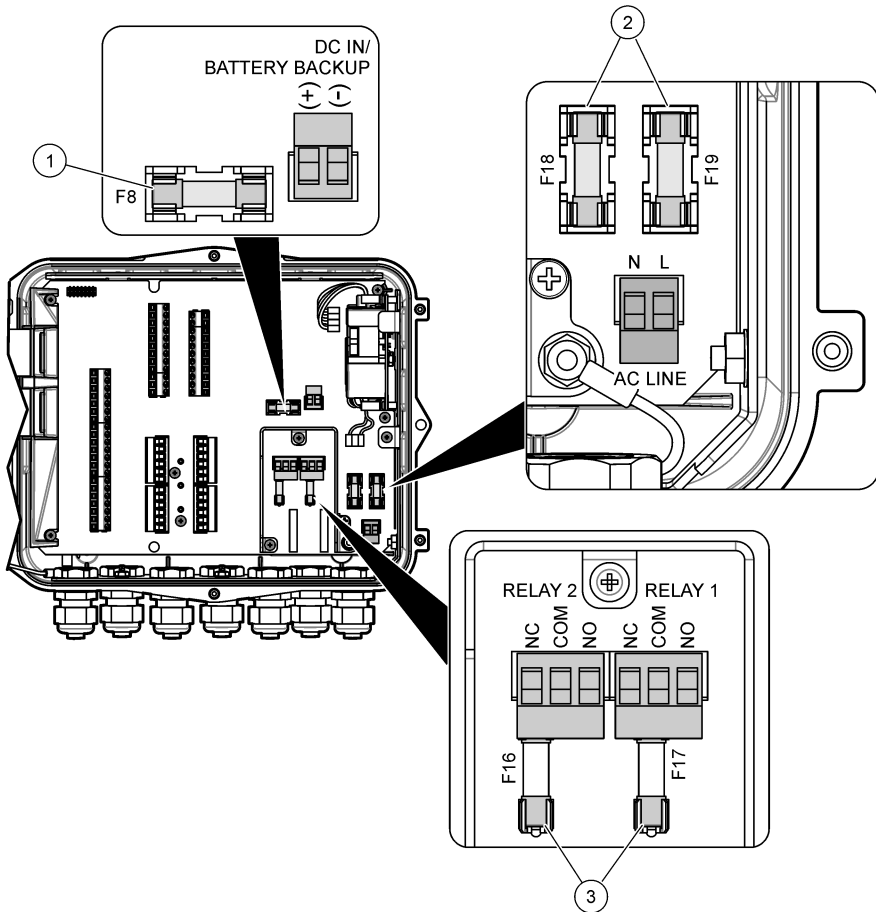


Fire hazard. Use the same type and current rating to replace fuses.

The instrument contains fuses for the power and for the relays. Refer to [Specifications](#) on page 3. A blown fuse can be an indication that the instrument has a problem and that service is necessary.

1. Remove the power to the instrument.
2. Remove the power to the relay connections.
3. Open the access door. Refer to [Open the access door](#) on page 13.
4. Remove the high-voltage barrier.
5. Replace the fuse with a fuse of the same type and rating. Refer to [Figure 19](#) and [Replacement parts and accessories](#) on page 44.
6. Install the high-voltage barrier.
7. Install the access door.

**Figure 19 Fuse location**

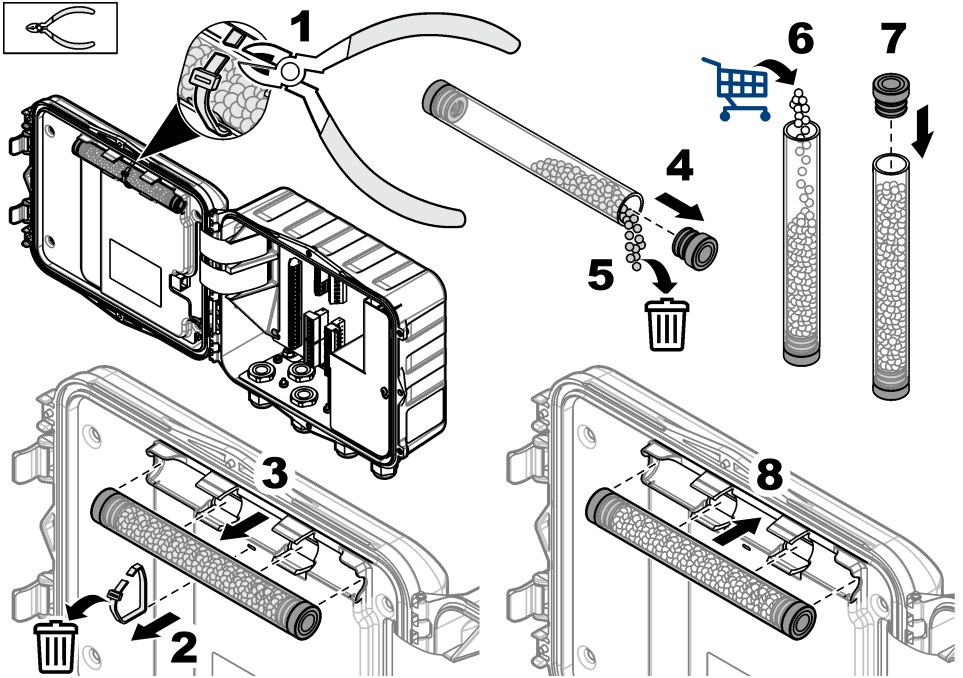


1 DC fuse	3 Relay fuse
2 AC fuse	

### 7.4 Replace the internal desiccant

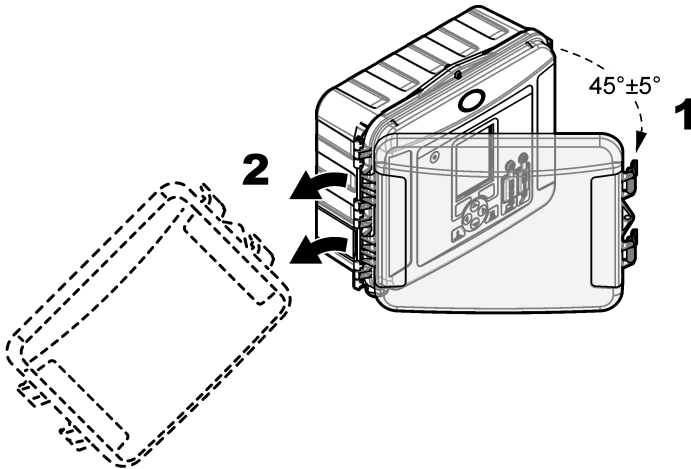
The desiccant absorbs moisture to prevent component damage. The color of new desiccant is orange. When the desiccant is full of moisture, the color of the desiccant changes to green. Replace the desiccant when the color of the desiccant is green. Replace the desiccant tube or empty the tube and fill with new desiccant (Figure 20).

Figure 20 Replace the desiccant



### 7.5 Remove the cover (optional)

The instrument cover can be removed temporarily for maintenance tasks. Make sure to keep the cover on during operation to prevent direct exposure to environmental conditions. Refer to the illustrated steps that follow.



## Section 8 Troubleshooting

Use the diagnostic menu to see the recorded events and alarms and to find the possible source of a problem.

1. Push **MENU**.
2. Select Diagnostics.
3. Select an option:

Option	Description
<b>Status</b>	Gives the number of logged channels, the active channel, totalizer info, and sensor port connections.
<b>Event Log</b>	Shows the total number of events and individual events.
<b>Alarm Log</b>	Shows the total number of alarms and the individual alarms.
<b>Sensor Ports</b>	Queries a sensor port to take a measurement or go to diagnostic logging interval of 1 hour, 1 day or 1 week.
<b>Internal I/O</b>	Gives diagnostic information for the relays, inputs and outputs in the instrument.
<b>Keypad</b>	Starts a test for the keypad to make sure that all of the keys operate correctly.
<b>Display</b>	Starts a test for the display.
<b>Data Log Used %</b>	Gives the percent of the used datalog memory.

## Section 9 Replacement parts and accessories

**Note:** Product and Article numbers may vary for some selling regions. Contact the appropriate distributor or refer to the company website for contact information.

### Replacement parts

Description	Item no.
Cover assembly with latches, clear	8319100
Desiccant tube assembly, internal	8314000
Desiccant, bulk beads	8755500
Fuse, 3.15 A, 250 VAC	590765
Fuse, 10 A, 250 VDC	8309900
Latch for clear cover	8306900
Plug for air tube ports	8305800
Power cable, 115 VAC, 10 A, 2.4 m (8 ft) (US)	8317900
Power cable (EU)	8318000
Power cable (UK)	8318100
Power cable (AU)	8318200
Strain relief plugs, 11 mm (7/16 in.) diameter	6250700
USB Type A to B cable	8317800
USB Type A port cover	8306300
USB Type B port cover	8307500

## Accessories

Description	Item no.
Backup battery, 12 VDC lead acid	8757400
Backup battery/power supply mounting bracket	8315500
Backup battery power supply	8754500XX <sup>4</sup>
Backup battery 3-pin half cable	8307900
Bracket for AV9000S, BL9000 bubbler	8309300
Cable, half, to AS950 sampler, 2.7 m (9 ft)	8528500
Cable, half, to AS950 sampler, 7.6 m (25 ft)	8528501
Desiccant cartridge with tubing, external sensors (required for Flo-Dar and Flo-Tote)	8321200
pH sensor adapter cable	8308000
Pipe mounting kit	8319000
Rain gauge	8307800
Solar panel option	varies <sup>5</sup>
Sun/rain shield	8319200
Totalizer, electromechanical	8307700
Ultrasonic sensor extension cable, 30.5 m (100 ft)	8315200
Ultrasonic sensor extension cable, 82.3 m (270 ft)	8315201

<sup>4</sup> XX=US, EU, AU, UK

<sup>5</sup> Contact technical support to select the correct components for solar power.









**McCrometer, Inc.**

3255 West Stetson Avenue

Hemet, CA 92545 USA

Tel: 951-652-6811

800-220-2279

Fax: 951-652-3078

[hachflowtechsupport@mccrometer.com](mailto:hachflowtechsupport@mccrometer.com)

[www.hach.com/flow](http://www.hach.com/flow)

USA Copyright © McCrometer, Inc. All printed material should not be changed or altered without permission of McCrometer. Any published pricing, technical data, and instructions are subject to change without notice. Contact your McCrometer representative for current pricing, technical data, and instructions.

---

© McCrometer, Inc., 2017, 2024.

All rights reserved.