

Document Number DGG1200-MAN/E

# ORBISPHERE Model G1200 Sensor and 510 Analyzer

USER MANUAL

September 2009, Version C





---

<b>Section 1 General Information</b> .....	5
1.1 Disclaimer .....	5
1.2 Safety information .....	5
1.2.1 Use of hazard information .....	5
1.2.2 Service and repairs .....	5
1.2.3 Safety precautions .....	6
1.2.4 Intended use of this equipment .....	6
1.2.5 Precautionary labels .....	7
1.3 Product recycling information .....	8
1.4 Product disposal .....	10
1.5 Restriction of hazardous substances (RoHS) .....	11
<b>Section 2 Specifications</b> .....	13
2.1 Technical specifications .....	13
2.2 General principle of operation .....	15
2.3 Hardware description .....	16
2.4 Model identification system .....	17
2.5 Security level table .....	18
2.6 Default parameters .....	19
<b>Section 3 Installation</b> .....	21
3.1 Unpacking .....	21
3.2 Installation check list .....	21
3.3 Wall mount and pipe mount instruments .....	22
3.3.1 Instrument dimensions .....	22
3.3.2 Wall mounting .....	23
3.3.3 Pipe mounting .....	23
3.3.4 Connection panel (bottom of instrument) .....	24
3.4 Panel mount instrument .....	26
3.4.1 Instrument dimensions .....	26
3.4.2 Mounting .....	27
3.4.3 Connection panel (bottom of instrument) .....	28
3.5 Connectors assembly instructions .....	29
3.5.1 Cable gland wiring instructions .....	29
3.5.2 USB-B client adapter cable .....	30
3.6 Connection to mains power supply .....	30
3.6.1 Power supply connection (low voltage instruments) .....	30
3.6.2 Power supply connection (high voltage instruments) .....	31
3.7 Connections to electronic boards .....	33
3.7.1 Electronic boards connectors .....	33
3.7.2 Main board connections .....	33
3.7.3 Measurement board .....	34
3.8 Measurement alarm relays .....	34
3.9 Sensor installation .....	35
3.9.1 Instrument connections .....	35
3.9.2 Flow chamber .....	36
3.9.3 Flow rate .....	37
3.9.4 Calibration gas .....	37
<b>Section 4 User Interface</b> .....	39
4.1 Instrument .....	39
4.2 Touch screen .....	39
4.2.1 Function keys on the header bar .....	40
4.2.2 Menu navigation .....	41
4.2.3 Rolling list .....	41
4.2.4 Virtual keyboard .....	41
4.2.5 Identification and authorization level .....	42

---

## Table of Contents

---

4.2.6 Warning windows .....	42
4.3 Main menu structure.....	43
<b>Section 5 View Menu .....</b>	<b>45</b>
5.1 Selection of the view style .....	46
5.1.1 Numeric view .....	46
5.1.2 Diagnostic view .....	46
5.1.3 Statistic view.....	46
5.2 Configuration of the view styles.....	48
5.2.1 Numeric view configuration .....	48
5.2.2 Statistic view configuration .....	48
<b>Section 6 Measurement Menu .....</b>	<b>49</b>
6.1 Instrument configuration.....	49
6.2 Measurement configuration.....	50
6.2.1 Measurement alarms configuration .....	50
6.2.2 Measurement filter configuration .....	51
6.3 Measured data storage .....	52
<b>Section 7 Calibration Menu .....</b>	<b>53</b>
7.1 Sensor calibration.....	54
7.1.1 Initial sensor calibration .....	54
7.1.2 Automatic calibration .....	55
7.1.3 Manual calibration .....	55
7.2 Calibration configuration.....	56
7.2.1 Configure automatic calibration .....	57
7.2.2 Configure manual calibration.....	57
7.2.3 Zero calibration.....	58
7.2.4 High-level adjustment.....	58
7.3 Sensor verification.....	59
7.4 Barometric pressure calibration.....	59
7.5 Calibration reports .....	59
<b>Section 8 Inputs/Outputs Menu .....</b>	<b>61</b>
8.1 Configure snooze .....	61
8.2 View inputs/outputs .....	62
8.3 Relays .....	62
8.3.1 Relays configuration.....	62
8.3.2 Test channel relays .....	63
8.3.3 Test system relay .....	63
8.4 Analog outputs .....	64
8.4.1 Instrument configuration.....	65
8.4.2 Channel configuration .....	66
8.4.3 Calibration of the analog output .....	68
8.4.4 Direct test .....	69
8.4.5 Characteristics test.....	69
8.5 Analog output characteristics .....	69
8.5.1 "Linear" analog output .....	69
8.5.2 "Tri-linear" analog output.....	70
8.5.3 None.....	71
<b>Section 9 Communication Menu .....</b>	<b>73</b>
9.1 RS-485 simple mode configuration .....	74
9.1.1 Data available.....	75
9.1.2 Example of use.....	77
9.2 PROFIBUS-DP communication (optional).....	78
9.2.1 Installation .....	78
9.2.2 Input/Output data.....	79

9.3 USB-A port (host).....	82
9.4 HTTP/TCP-IP.....	82
9.4.1 Overview.....	82
9.4.2 PC interface.....	83
9.5 Data file transfer through the USB-B port (client).....	84
9.5.1 PC software installation.....	84
9.5.2 Microsoft ActiveSync® configuration.....	86
9.5.3 Upload report files.....	87
<b>Section 10 Security Menu.....</b>	<b>89</b>
10.1 Access rights management.....	89
10.2 Configure security.....	90
10.3 User management.....	90
10.4 User action log file.....	90
<b>Section 11 Products Menu.....</b>	<b>91</b>
11.1 Overview.....	91
11.1.1 Select product.....	92
11.1.2 Modify product.....	92
<b>Section 12 Global Configuration Menu.....</b>	<b>93</b>
12.1 Overview.....	93
12.1.1 Save.....	93
12.1.2 Select.....	93
<b>Section 13 Services Menu.....</b>	<b>95</b>
13.1 Sensor diagnostics.....	97
13.1.1 Calibration timer.....	97
13.1.2 Service timer.....	97
13.2 Language selection.....	97
13.3 Clock.....	98
13.4 Screen.....	98
13.4.1 Screen calibration.....	98
13.4.2 Screen contrast.....	98
13.5 Buzzer.....	98
13.6 Boards info.....	99
13.6.1 Main board info.....	99
13.6.2 Measurement board info.....	99
13.6.3 Sensor parameters.....	99
13.7 Batteries.....	100
13.8 Software download.....	100
13.9 End application.....	100
<b>Section 14 Maintenance and Troubleshooting.....</b>	<b>101</b>
14.1 Instrument maintenance.....	101
14.2 Sensor maintenance.....	101
14.2.1 Equipment required.....	101
14.2.2 Sensor spot removal.....	101
14.2.3 Sensor spot replacement.....	102
14.3 Storage, handling and transportation.....	102
14.4 Troubleshooting.....	103
14.5 List of events and alarms.....	104
<b>Section 15 Part Lists.....</b>	<b>105</b>
15.1 Accessories and spare parts.....	105
15.2 Instrument options.....	106
<b>Section 16 Glossary.....</b>	<b>107</b>
16.1 Gas units.....	107

## Table of Contents

---

16.2 Generic terms and definitions.....	107
---	-----

# Section 1 General Information

---

## 1.1 Disclaimer

The information in this manual has been carefully checked and is believed to be accurate. However, Hach Lange assumes no responsibility for any inaccuracies that may be contained in this manual. In no event will Hach Lange be liable for direct, indirect, special, incidental, or consequential damages resulting from any defect or omission in this manual, even if advised of the possibility of such damages. In the interest of continued product development, Hach Lange reserves the right to make improvements in this manual and the products it describes at any time, without notice or obligation.

Copyright © 2009 by Hach Lange. All rights reserved. No part of the contents of this manual may be reproduced or transmitted in any form or by any means without the written permission of Hach Lange.

## 1.2 Safety information

Please read the entire manual before unpacking, setting up, or operating this analyzer.

Pay particular attention to all warning and caution statements. Failure to do so could result in serious injury to the operator or damage to the equipment.

To ensure the protection provided by this equipment is not impaired, do not use or install this equipment in any manner other than that which is specified in this manual.

### 1.2.1 Use of hazard information

#### **WARNING**

***A warning is used to indicate a condition which, if not met, could cause serious personal injury and/or death. Do not move beyond a warning until all conditions have been met***

#### **CAUTION**

***A caution is used to indicate a condition which, if not met, could cause minor or moderate personal injury and/or damage to the equipment. Do not move beyond a caution until all conditions have been met.***

***Note:*** A note is used to indicate important information or instructions that should be considered before operating the equipment.

### 1.2.2 Service and repairs

None of the analyzer's components can be serviced by the user. Only personnel from Hach Lange or its approved representative(s) is (are) authorized to attempt repairs to the system and only components formally approved by the manufacturer should be used. Any attempt at repairing the analyzer in contravention of these principles could cause damage to the analyzer and corporal injury to the person carrying out the repair. It renders the warranty null and void and could compromise the correct working of the analyzer and the electrical integrity or the CE compliance of the analyzer.

If you have any problems with installation, starting, or using the analyzer please contact the company that sold it to you. If this is not possible, or if the results of this approach are not satisfactory, please contact the manufacturer's Customer Service.

### 1.2.3 Safety precautions



#### **WARNING**

*The installation of the instrument should be performed exclusively by personnel specialized and authorized to work on electrical installations, in accordance with relevant local regulations. Disconnect the power supply of the instrument before carrying out any work inside the instrument. In addition, and in accordance with safety standards, it must be possible to disconnect the power supply of the instrument in its immediate vicinity.*

#### **CAUTION**

*Proper ESD (electrostatic discharge) protocols must be followed to prevent damage to the product. All fittings must be properly seated and tightened to prevent water and dust ingress.*



#### **WARNING**

- *Do not connect the instrument to any electrical source that uses a 230V IT neutral regime.*
- *A bipolar circuit breaker must be installed in a 2-phase mains power supply without neutral.*
- *Always disconnect the instrument before any intervention.*
- *The power cord plug connection is also used as a main power switch.*
- *Access to the internal components of the instrument is restricted to Hach Lange or its representatives.*
- *All external connectors, except the POWER in the wall and panel models, are of Very Low Voltage Safety (< 50V). They should be connected only on apparatus with the same characteristics.*
- *The instrument must be connected to an electrical system which complies with applicable local regulations.*
- *All the cables connected to the instrument must be fire resistant, type UL94V-1*
- *The operator must read and understand this manual before using the instrument.*
- *The instrument will not be used as a safety device. It does not provide a security function in a hazardous process.*









### 1.2.4 Intended use of this equipment

This version of the high accuracy Orbisphere 510 instrument uses a luminescent G1200 sensor to determine dissolved oxygen concentrations in water samples, and is particularly suitable for nuclear power plant water processes.



### 1.2.5 Precautionary labels

Read all labels and tags attached to the analyzer. Personal injury or damage to the analyzer could occur if not observed.

	This symbol, when noted on a product, indicates a potential hazard which could cause serious personal injury and/or death. The user should reference this instruction manual for operation and/or safety information.
	This symbol, when noted on a product enclosure or barrier, indicates that a risk of electrical shock and/or electrocution exists and indicates that only individuals qualified to work with hazardous voltages should open the enclosure or remove the barrier.
	This symbol, when noted on the product, indicates that the marked item can be hot and should not be touched without care.
	This symbol, when noted on the product, indicates the presence of devices sensitive to electrostatic discharge and indicates that care must be taken to prevent damage to them.
	This symbol, when noted on the product, identifies a risk of chemical harm and indicates that only individuals qualified and trained to work with chemicals should handle chemicals or perform maintenance on chemical delivery systems associated with the equipment.
	This symbol, if noted on the product, indicates the need for protective eye wear.
	This symbol, when noted on the product, identifies the location of the connection for protective earth (ground).
	Electrical equipment marked with this symbol may not be disposed of in European public disposal systems. In conformity with European local and national regulations, European electrical equipment users must now return old or end-of-life equipment to the manufacturer for disposal at no charge to the user.
	Products marked with this symbol indicates that the product contains toxic or hazardous substances or elements. The number inside the symbol indicates the environmental protection use period in years.

### 1.3 Product recycling information

	<p><b>ENGLISH</b></p> <p>Electrical equipment marked with this symbol may not be disposed of in European public disposal systems after 12 August 2005. In conformity with European local and national regulations (EU Directive 2002/96/EC), European electrical equipment users must now return old or end-of-life equipment to the manufacturer for disposal at no charge to the user.</p> <p><b>Note:</b> For return for recycling, please contact the equipment manufacturer or supplier for instructions on how to return end-of-life equipment for proper disposal.</p>
	<p><b>DEUTSCH</b></p> <p>Elektrogeräte, die mit diesem Symbol gekennzeichnet sind, dürfen in Europa nach dem 12. August 2005 nicht mehr über die öffentliche Abfallentsorgung entsorgt werden. In Übereinstimmung mit lokalen und nationalen europäischen Bestimmungen (EU-Richtlinie 2002/96/EC), müssen Benutzer von Elektrogeräten in Europa ab diesem Zeitpunkt alte bzw. zu verschrottende Geräte zur Entsorgung kostenfrei an den Hersteller zurückgeben.</p> <p><b>Hinweis:</b> Bitte wenden Sie sich an den Hersteller bzw. an den Händler, von dem Sie das Gerät bezogen haben, um Informationen zur Rückgabe des Altgeräts zur ordnungsgemäßen Entsorgung zu erhalten.</p>
<p><b>FRANCAIS</b></p> <p>A partir du 12 août 2005, il est interdit de mettre au rebut le matériel électrique marqué de ce symbole par les voies habituelles de déchetterie publique. Conformément à la réglementation européenne (directive UE 2002/96/EC), les utilisateurs de matériel électrique en Europe doivent désormais retourner le matériel usé ou périmé au fabricant pour élimination, sans frais pour l'utilisateur.</p> <p><b>Remarque:</b> Veuillez vous adresser au fabricant ou au fournisseur du matériel pour les instructions de retour du matériel usé ou périmé aux fins d'élimination conforme.</p>	
<p><b>ITALIANO</b></p> <p>Le apparecchiature elettriche con apposto questo simbolo non possono essere smaltite nelle discariche pubbliche europee successivamente al 12 agosto 2005. In conformità alle normative europee locali e nazionali (Direttiva UE 2002/96/EC), gli utilizzatori europei di apparecchiature elettriche devono restituire al produttore le apparecchiature vecchie o a fine vita per lo smaltimento senza alcun costo a carico dell'utilizzatore.</p> <p><b>Nota:</b> Per conoscere le modalità di restituzione delle apparecchiature a fine vita da riciclare, contattare il produttore o il fornitore dell'apparecchiatura per un corretto smaltimento.</p>	
<p><b>DANSK</b></p> <p>Elektriske apparater, der er mærket med dette symbol, må ikke bortskaffes i europæiske offentlige affaldssystemer efter den 12. august 2005. I henhold til europæiske lokale og nationale regler (EU-direktiv 2002/96/EF) skal europæiske brugere af elektriske apparater nu returnere gamle eller udtjente apparater til producenten med henblik på bortskaffelse uden omkostninger for brugeren.</p> <p><b>Bemærk:</b> I forbindelse med returnering til genbrug skal du kontakte producenten eller leverandøren af apparatet for at få instruktioner om, hvordan udtjente apparater bortskaffes korrekt.</p>	

**SVENSKA**

Elektronikutrustning som är märkt med denna symbol kanske inte kan lämnas in på europeiska offentliga sopstationer efter 2005-08-12. Enligt europeiska lokala och nationella föreskrifter (EU-direktiv 2002/96/EC) måste användare av elektronikutrustning i Europa nu återlämna gammal eller uttrangerad utrustning till tillverkaren för kassering utan kostnad för användaren.

**Obs!** Om du ska återlämna utrustning för återvinning ska du kontakta tillverkaren av utrustningen eller återförsäljaren för att få anvisningar om hur du återlämnar kasserad utrustning för att den ska bortskaffas på rätt sätt.

**ESPAÑOL**

A partir del 12 de agosto de 2005, los equipos eléctricos que lleven este símbolo no deberán ser desechados en los puntos limpios europeos. De conformidad con las normativas europeas locales y nacionales (Directiva de la UE 2002/96/EC), a partir de esa fecha, los usuarios europeos de equipos eléctricos deberán devolver los equipos usados u obsoletos al fabricante de los mismos para su reciclado, sin coste alguno para el usuario.

**Nota:** *Sírvase ponerse en contacto con el fabricante o proveedor de los equipos para solicitar instrucciones sobre cómo devolver los equipos obsoletos para su correcto reciclado.*

**NEDERLANDS**

Elektrische apparatuur die is voorzien van dit symbool mag na 12 augustus 2005 niet meer worden afgevoerd naar Europese openbare afvalsystemen. Conform Europese lokale en nationale wetgeving (EU-richtlijn 2002/96/EC) dienen gebruikers van elektrische apparaten voortaan hun oude of afgedankte apparatuur kosteloos voor recycling of vernietiging naar de producent terug te brengen.

**Nota:** *Als u apparatuur voor recycling terugbrengt, moet u contact opnemen met de producent of leverancier voor instructies voor het terugbrengen van de afgedankte apparatuur voor een juiste verwerking.*

**POLSKI**

Sprzęt elektryczny oznaczony takim symbolem nie może być likwidowany w europejskich systemach utylizacji po dniu 12 sierpnia 2005. Zgodnie z europejskimi, lokalnymi i państwowymi przepisami prawa (Dyrektywa Unii Europejskiej 2002/96/EC), użytkownicy sprzętu elektrycznego w Europie muszą obecnie przekazywać Producentowi stary sprzęt lub sprzęt po okresie użytkowania do bezpłatnej utylizacji.

**Uwaga:** *Aby przekazać sprzęt do recyklingu, należy zwrócić się do producenta lub dostawcy sprzętu w celu uzyskania instrukcji dotyczących procedur przekazywania do utylizacji sprzętu po okresie użytkowania.*

**PORTUGUES**

Qualquer equipamento eléctrico que ostente este símbolo não poderá ser eliminado através dos sistemas públicos europeus de tratamento de resíduos sólidos a partir de 12 de Agosto de 2005. De acordo com as normas locais e europeias (Directiva Europeia 2002/96/EC), os utilizadores europeus de equipamentos eléctricos deverão agora devolver os seus equipamentos velhos ou em fim de vida ao produtor para o respectivo tratamento sem quaisquer custos para o utilizador.

**Nota:** *No que toca à devolução para reciclagem, por favor, contacte o produtor ou fornecedor do equipamento para instruções de devolução de equipamento em fim de vida para a sua correcta eliminação.*

### 1.4 Product disposal

*Note: The following only applies to European customers.*

Hach Lange is committed to ensuring that the risk of any environmental damage or pollution caused by any of its products is minimized as far as possible. The European Waste Electrical and Electronic Equipment (WEEE) Directive (2002/96/EC) that came into force on August 13 2005 aims to reduce the waste arising from electrical and electronic equipment; and improve the environmental performance of all those involved in the life cycle of electrical and electronic equipment.



In conformity with European local and national regulations (EU Directive 2002/96/EC stated above), electrical equipment marked with the above symbol may not be disposed of in European public disposal systems after 12 August 2005.

Hach Lange will offer to take back (**free of charge to the customer**) any old, unserviceable or redundant analyzers and systems which carry the above symbol, and which were originally supplied by Hach Lange. Hach Lange will then be responsible for the disposal of this equipment.

In addition, Hach Lange will offer to take back (**at cost to the customer**) any old, unserviceable or redundant analyzers and systems which do not carry the above symbol, but which were originally supplied by Hach Lange. Hach Lange will then be responsible for the disposal of this equipment.

Should you wish to arrange for the disposal of any piece of equipment originally supplied by Hach Lange, please contact your supplier or our After Sales Service department in Geneva for instructions on how to return this equipment for proper disposal.

## 1.5 Restriction of hazardous substances (RoHS)

The European Union RoHS Directive and subsequent regulations introduced in member states and other countries limits the use of six hazardous substances used in the manufacturing of electrical and electronic equipment.

Currently, monitoring and control instruments do not fall within the scope of the RoHS Directive, however Hach Lange has taken the decision to adopt the recommendations in the Directive as the target for all future product design and component purchasing.



This product is compliant with the European Union RoHS Directive.

**Note:** The following only applies to exports of this product into the People's Republic of China.



含有有毒或者危险物质及成分的产品。

环保使用期限标记（年）

部件名称	有毒或者危险物质和成分					
	铅	汞	镉	六价铬	多溴联苯	多溴联苯醚
Locking system	X					
Spacer	X					
External connectors	X					
Sensor head	X					
O: 表示所有此类部件的材料中所含有毒或危险物质低于限制要求 X: 表示至少有一种此类部件材料中所含有毒或危险物质高于限制要求						





## Section 2 Specifications

Specifications are subject to change without notice.

### 2.1 Technical specifications

OPERATING CONDITIONS	
Operating temperature limits	-5°C to +50°C
Storage temperature limits	-20°C to +70°C
Operating humidity limits	0 to 95% non condensing relative humidity
Operating altitude	From 0 to 2,000 m. (6,550 ft.) above sea level
EMC requirements	EN61326:1997 /A1:1998 /A2:2001 /A3:2003  <i>Note: The wall mount instrument is a Class A product. In a domestic environment this product may cause radio interference in which case the user may be required to take adequate measures.</i>
CE compliance	EN61010-1: 2001 Directive 73/23/EEC
Safety rating	ETL, conforming to UL 61010-1 and CSA 22.2 No. 61010-1
Enclosure ratings	IP 65, NEMA 4X Totally protected against dust. Protected against low pressure jets of water from all directions.
MEASUREMENT	
Range	0 to 20,000 ppb
Repeatability (r <sup>95</sup> )	± 1 ppb ± 2% in the 0 to 600 ppb range
Reproducibility	± 2 ppb ± 2.5% in the 0 to 600 ppb range
Accuracy	± 2 ppb ± 2.5% in the 0 to 600 ppb range (indicative ± 15% in the ppm range)
Lowest detection limit	2 ppb
Response time (90%)	30 seconds
Display resolution	0.1 ppb
Calibration	Fully automatic user programmable single point zero calibration
Verification	Fully automatic user programmable single point zero verification
Calibration sample	Standard 99.999% N <sub>2</sub> (quality 50) gas bottles with 5/8" x 18 (C10) connection. Ask your local Hach Lange representative for advice on local suppliers. Dedicated pressure regulator is available from Hach Lange
POWER SUPPLY	
Power supply	Universal 100 VAC to 240 VAC @ 50/60Hz - 40VA 10 to 30 VDC - 30W
COMMUNICATION	
Options	RS-485 or PROFIBUS-DP (optional) USB client USB host Ethernet 10/100 Base-T
SIZE AND WEIGHT	
Wall and pipe mount (H x D x W)	236.5 x 160 x 250 mm - weight 3.8 kg 9.31 x 6.30 x 9.84 ins. - weight 8.38 lbs
Panel mount: Face (housing) (H x D x W)	156 (123) x 250 x 220 (214) mm - weight 2.9 kg 6.14 (4.84) x 9.84 x 8.86 (8.43) ins. - weight 6.39 lbs

## Specifications

<b>ANALOG OUTPUTS</b>	
Analog current output version on the measurement board(s)	4-20 mA (default) or 0-20 mA (configuration with software) 3 configurable outputs Maximum load: 500 ohm Sensitivity: 20µA Accuracy: ± 0.5% (between operating temperature limits)
Analog voltage output version on the measurement board(s)	0- 5 V output (hardware option) 3 configurable outputs Minimum load: 10 KOhm Sensitivity: 5 mV Accuracy: ± 0.5% (between operating temperature limits)
<b>DIGITAL OUTPUTS</b>	
Measurement alarm relays on the measurement board	Three alarm relays 1A-30 VAC or 0.5A-50 VDC on a resistance load Configurable to Normally Open [NO] or Normally Closed [NC] contacts by changing the jumper positions.  <div style="text-align: center;">  <p><b>WARNING</b> Connect only safety low voltage &lt;33 VAC RMS</p> </div>
System alarm relay on the main board	One "instrument system alarm" relay per instrument 1A-30 VAC or 0.5A-50 VDC on a resistance load Normally closed [NC] (NO relay also available) when instrument is turned on. Opens when a system alarm is detected, and when it does not receive any signal.  <div style="text-align: center;">  <p><b>WARNING</b> Connect only safety low voltage &lt;33 VAC RMS</p> </div>



## 2.2 General principle of operation

Optical sensing of oxygen originates from the work of Kautsky in 1939 where he demonstrated that oxygen can dynamically quench the fluorescence of an indicator (decrease the quantum yield). This principle has been reported in various fields of application such as monitoring aquatic biology in waste water, tests for blood gas analysis and cell culture monitoring. The method is now recognized by ASTM (American Society for Testing and Materials) for the measurement of oxygen in water. Compared to classical oxygen detection using electrochemical sensors, luminescent technology offers several advantages such as no oxygen consumption, independence from sample flow velocity, no electrolyte and low maintenance.

Optical sensing of oxygen is based on the measurement of the red fluorescence of a dye/indicator illuminated with a blue light as shown in Figure 1.

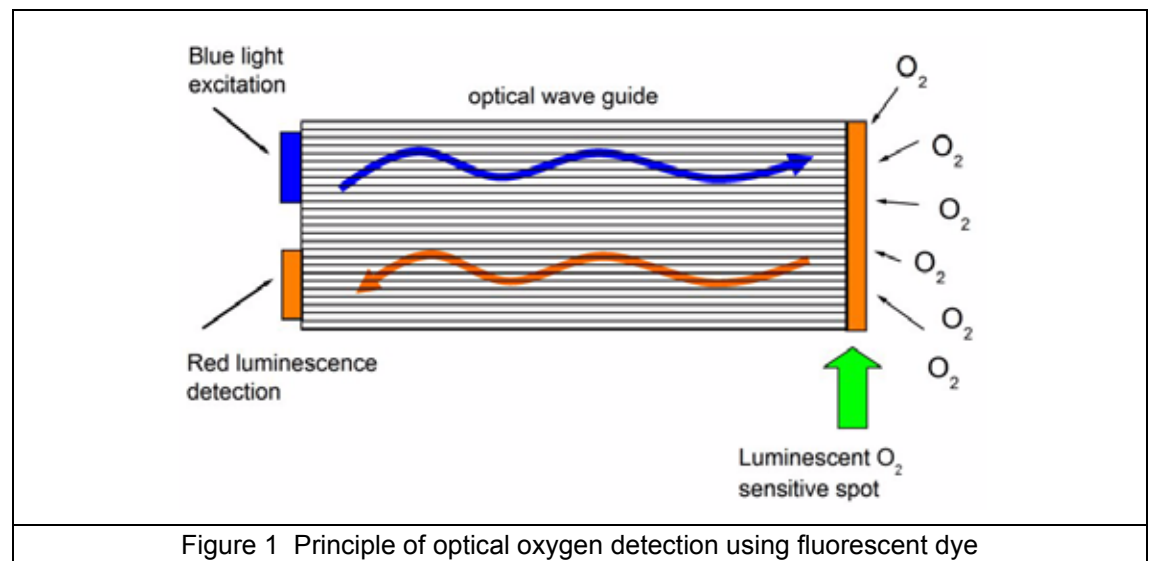

The dye fluorescence is quenched by the presence of oxygen. The oxygen concentration can be calculated by measuring the decay time of the fluorescence intensity as shown by Figure 2 left. The higher the oxygen concentration is, the shorter the decay time will be. By modulating the excitation, the decay time is transformed into a phase-shift of the modulated fluorescence signal, which is independent of fluorescent intensity and thus of potential aging (Figure 2 right).

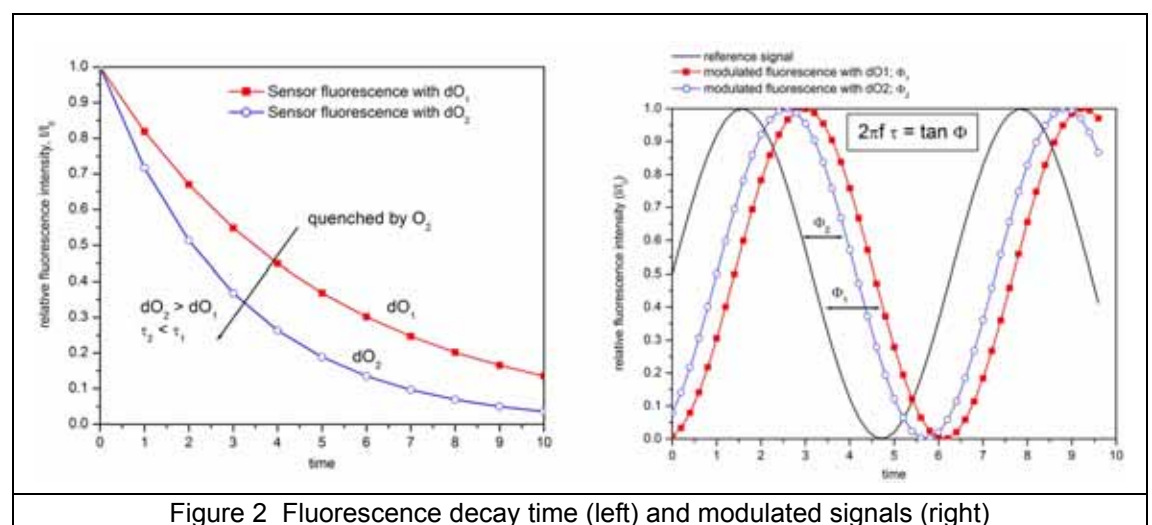

The oxygen partial pressure ( $pO_2$ ) is then linked to the corresponding phase-shift measurement ( $\Phi$ ) to build the sensor calibration curve (shown right in Figure 3 below). This curve is described by the Stern-Volmer equation (shown left in Figure 3 below) where  $K_{sv}$  is the indicator quenching constant (in  $mbar^{-1}$ ) representing the quenching efficiency of the oxygen and thus the sensor sensitivity,  $f_0$  is a constant and  $\Phi_0$  is the phase-shift at zero oxygen representing the unquenched fluorescence decay time of the dye. The calibration curve thus relies on two parameters: the phase-shift at zero oxygen and the luminescent spot sensitivity,  $K_{sv}$ . The dissolved oxygen concentration is then calculated with Henry's law using the water solubility curve as a function of the temperature.

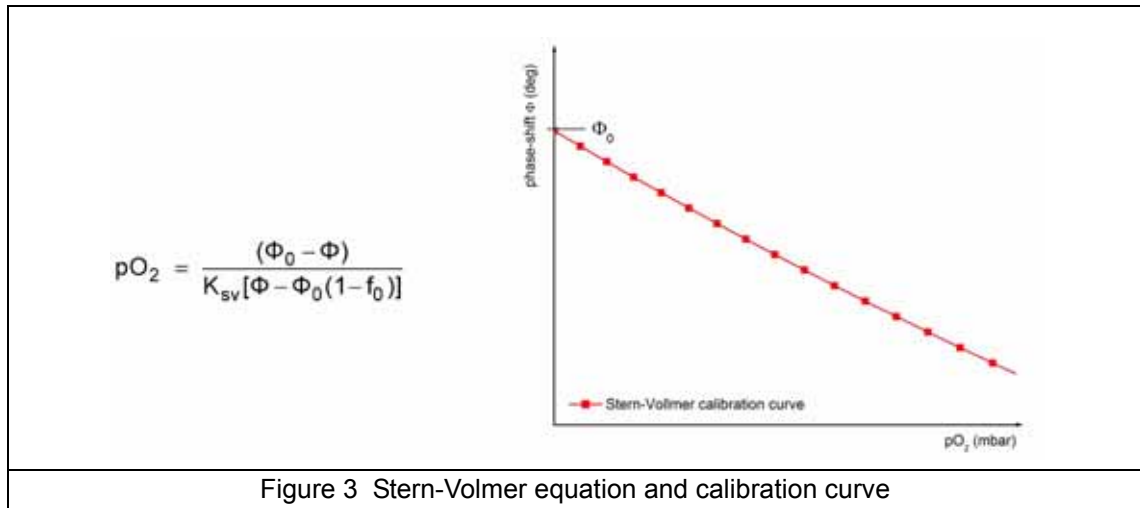

Figure 3 Stern-Volmer equation and calibration curve

### 2.3 Hardware description

The instrument hardware is made of one main board, and one measurement board for the measurement channel (= the sensor).

The main board includes the controls for power, display, the touch screen, the barometric sensor, the alarms, and communication ports. The measurement board performs measurements and executes commands from the main board. It holds the "Analog output" and "Relays" that send information to external systems.

A hardware watchdog is activated at program start up, to check that the system is not frozen (i.e. infinite loop, system crash, etc.). If the watchdog is not refreshed by the software every minute, the measurement display, the relays and the analog output are frozen up to 2 minutes. Then the reset shuts down the instrument for 10 seconds and the start-up procedure is performed. At the same time all the hardware (sensor, measurement board) are reset.



## 2.5 Security level table

A cross means that the user who has this user security level can access this function or setting (see [User management on page 90](#)).

**Note:** When not shown, the sub-levels carry the same security level as the level above.

View	0	1	2	3	4
Measurement	X	X	X	X	X
Calibration			X	X	X
Inputs/outputs			X	X	X
Communication				X	X
Security				X	X
Products			X	X	X
Global config				X	X
Services				X	X

Numeric	0	1	2	3	4
Graphic	X	X	X	X	X
Statistical	X	X	X	X	X
Event	X	X	X	X	X
Diagnostic	X	X	X	X	X
Configure				X	X

Measurement	0	1	2	3	4
Config instrument				X	X
Config channel				X	X
Measurement file				X	X

Calibration	0	1	2	3	4
Gas sensor			X	X	X
Barometer				X	X
External pressure				X	X
Amplifiers				X	X
Reports			X	X	X

Inputs/Outputs	0	1	2	3	4
Snooze				X	X
View			X	X	X
Relays				X	X
Analog outputs				X	X

Communication	0	1	2	3	4
RS 485				X	X
RS 485 simple				X	X
Profibus DP				X	X
USB-A				X	X
HTTP / TCP/IP				X	X

Security	0	1	2	3	4
Configuration					X
Access table					X
View log file				X	X

Products	0	1	2	3	4
Select product			X	X	X
Modify product				X	X

Global config	0	1	2	3	4
Save config				X	X
Select config				X	X

Services	0	1	2	3	4
Diagnostic				X	X
Language				X	X
Clock				X	X
Screen				X	X
Buzzer				X	X
Boards info				X	X
Batteries				X	X
Soft download				X	X
More				X	X

Diagram Legend:					
Security level :	0	1	2	3	4
Available			X	X	X
Optional				X	X
Not available today				X	X

Gas sensor	0	1	2	3	4
Calibration				X	X
Verification				X	X
Configuration				X	X
Reports				X	X

Reports	0	1	2	3	4
Sensor			X	X	X
Barometer				X	X

**Note:** For the USB-A option in the Communication Menu, level 4 access is required to import the access table data.

## 2.6 Default parameters

The table below indicates the factory default configurations. The instrument has these settings when started for the first time.

Parameter	Default settings	Customer settings
<b>Security</b>	Disabled	
<b>Measurement</b>		
Measurement mode	Continuous	
Data filter	Disabled	
Sample phase	Liquid	
Units	ppm-ppb	
Display resolution	XXX	
Storage mode	Rolling buffer	
<b>Temp unit</b>	°C	
<b>Pressure unit</b>	bar	
<b>Calibration</b>		
Mode	Zero calibration	
Hold	Enabled	
Auto-end	Enabled	
<b>Analog outputs</b>		
Range	4-20 mA (0-5V)	
Output	Gas measurement	
Extended mode	Disabled	
Characteristics	Linear mode	
<b>Alarm relays</b>	Disabled	
<b>Thermal cutoff</b>	Enabled	
Thermal cutoff temp	65°C	
<b>Calibration timer</b>	Disabled	
<b>Service timer</b>	Disabled	
<b>Buzzer</b>		
Screen tap	Enabled	
Alarm sound	Disabled	
<b>Display</b>		
Minigraph	Enabled	
Temperature	Disabled	



## Section 3 Installation

---



### **WARNING**

*This section provides necessary information to install and connect the analyzer. The installation of the analyzer should be performed in accordance with relevant local regulations. Disconnect the power supply of the analyzer before carrying out any work inside the analyzer. Any work inside the analyzer should be performed exclusively by personnel specialized and authorized to work on electrical installations. In addition, and in accordance with safety standards, it must be possible to disconnect the power supply of the analyzer in its immediate vicinity.*

### **CAUTION**

*Proper ESD (electrostatic discharge) protocols must be followed to prevent damage to the product when working with the electronic boards.*

## 3.1 Unpacking

Remove carefully the instrument and its accessories from the box and packing material, referring to the packing list included to confirm that everything has been delivered.

Please visually inspect the instrument for shipping damage. If anything is missing or damaged, contact the manufacturer or your dealer immediately.

You may want to retain the box and other packing material in case later you need to ship the instrument (see [Storage, handling and transportation on page 102](#)). Please dispose safely and ecologically of the box and packing material (if not stored for future use).

Please read through this manual thoroughly before carrying out the installation.

## 3.2 Installation check list

To complete the installation, proceed to the following actions following the instructions in this manual very carefully:

1. Install the 510 analyzer ([Section 3.3 on page 22](#) through [Section 3.8 on page 34](#))
2. Connect the G1200 sensor to the instrument ([Section 3.9.1 on page 35](#))
3. Attach the sensor to the flow chamber and connect the flow chamber to the sample flow, ensuring the sample outlet is directed to drain/waste ([Section 3.9.2 on page 36](#))
4. Connect the calibration gas bottle ([Section 3.9.4 on page 37](#)) ensuring the purity of the nitrogen gas is 99.999% or better
5. Turn the instrument on and set the operating language ([Section 13.2 on page 97](#))
6. Set the security levels, users ID's and passwords ([Section 10 on page 89](#))
7. If measuring in gas phase with fraction units (% , ppm), perform a barometric sensor calibration ([Section 7.4 on page 59](#))
8. Perform an initial gas sensor calibration using the manual zero calibration with auto-end enabled ([Section 7.1.1 on page 54](#))
9. Enable the auto-calibration feature ([Section 7.2 on page 56](#)) and set the auto calibration frequency ([Section 7.2.1 on page 57](#))

The instrument should now be ready for operation. If a problem should arise, please refer initially to [Troubleshooting on page 103](#). If the difficulty cannot be overcome, please contact your Hach Lange representative who will be happy to assist you.

### 3.3 Wall mount and pipe mount instruments

#### 3.3.1 Instrument dimensions

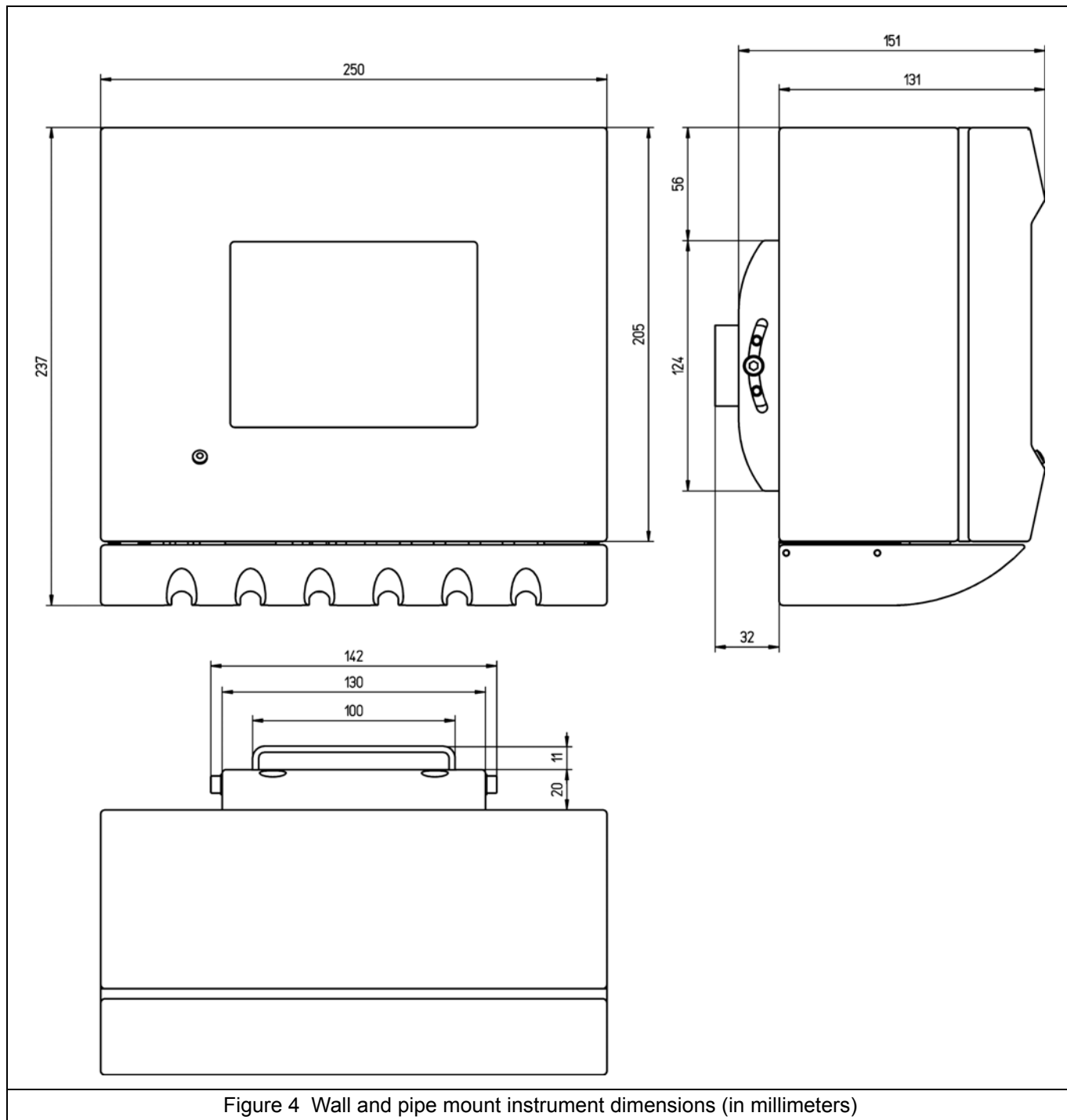

Figure 4 Wall and pipe mount instrument dimensions (in millimeters)



### 3.3.2 Wall mounting

		<p>Attach the U bracket provided to the wall with two screws (not provided).</p> <p>Tilt the instrument slightly backwards to align the bracket pins and the insertion slots, and slide the instrument onto the bracket as shown.</p> <p>Insert the 2 locking screws with washers through the side slots.</p> <p>Adjust instrument angle for better screen vision, and lock both side screws.</p>
<p>Figure 5 Wall mount bracket</p>		

### 3.3.3 Pipe mounting

	<p>Assemble the pipe mount bracket to the U-bracket, using the two screws provided</p> <p>Attach this assembly to the pipe using two clamps (not provided) as shown on the left</p> <p>The rest of the procedure is similar to the wall mount version, pictured above.</p> <p>Slide the instrument onto the bracket.</p> <p>Insert the 2 locking screws with washers through the side slots.</p> <p>Adjust the instrument angle for better screen vision, and lock both side screws.</p>
<p>Figure 6 Pipe mount diagram</p>	

### 3.3.4 Connection panel (bottom of instrument)

#### Cable protection shield

The cable protection located at the bottom of the instrument (shown in place in [Figure 7](#) below) must be lowered, and eventually removed, to get access to the bottom of the instrument.

Pull the plastic protection firmly towards you, then lower it as shown in [Figure 8](#) below. To remove it completely, push it back against the wall. Proceed in reverse order to install the cable protection. Make sure the 4 pins are securely in place.

#### Front panel door

A square key is provided to open the instrument front panel locks. The two locks are located on the right side of the instrument on the top and bottom panels (bottom panel indicated with the number 12 in [Figure 9](#) on the next page).

The front panel can be easily pivoted to the left as shown below. To retain the instrument waterproof tightness, make sure the seal is clean and in good condition before closing the front panel.



Figure 7 Cable protection shield in place and front door closed

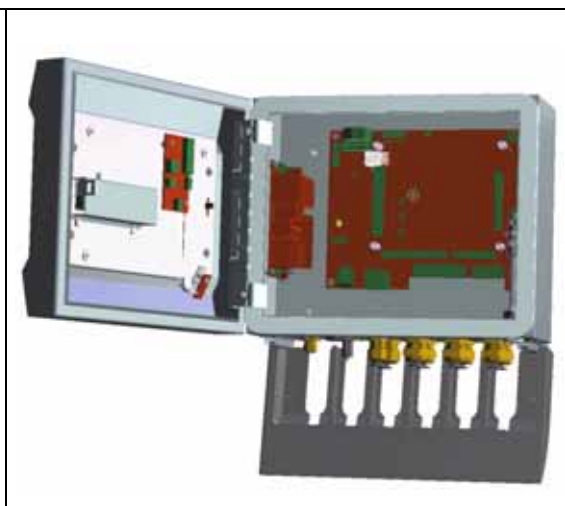

Figure 8 Cable protection shield lowered and front door open

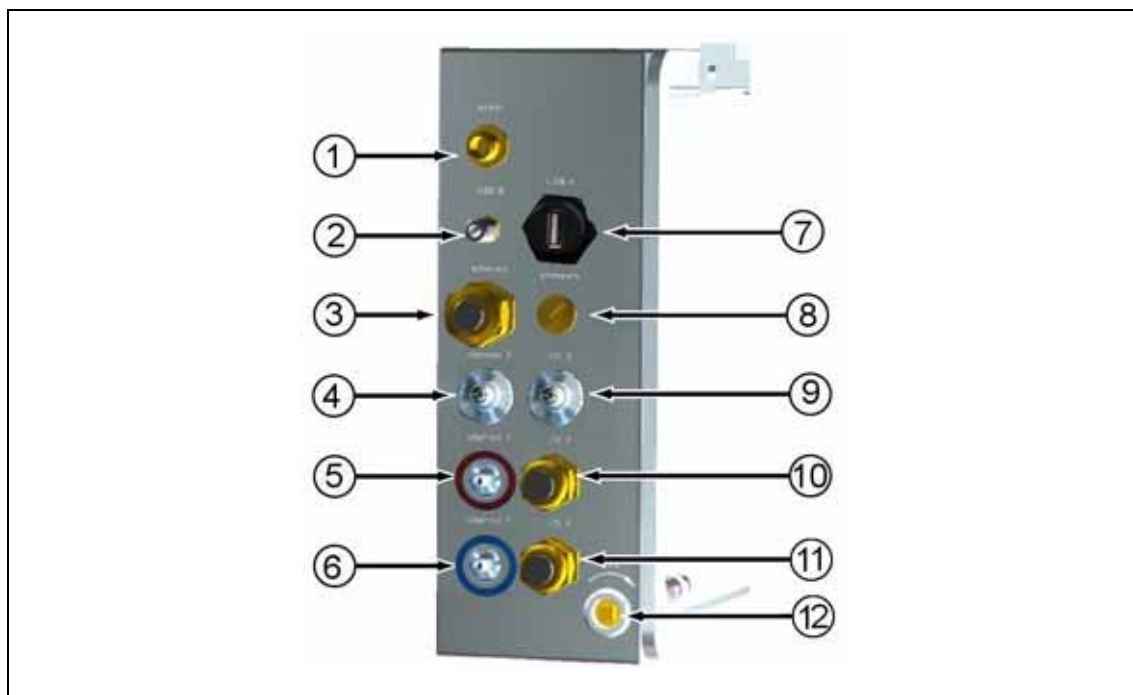

Figure 9 Wall and pipe mount connection panel

- |   |  |
|---|--|
| <ol style="list-style-type: none"> <li>1. Power cable. The type of connection will vary depending on the instrument specification (see <a href="#">Connection to mains power supply on page 30</a>)</li> <li>2. USB-B client 4 pin connector. Use the adapter cable (see <a href="#">USB-B client adapter cable on page 30</a>)</li> <li>3. Ethernet cable gland</li> <li>4. Sensor - temperature connection (black cable)</li> </ol> | <ol style="list-style-type: none"> <li>5. Sensor - red cable connection</li> <li>6. Sensor - blue cable connection</li> <li>7. USB-A host connector for mass storage device</li> <li>8. External pressure sensor connection</li> <li>9. Flow chamber solenoid valve connection</li> <li>10. Input/Output 2 cable gland</li> <li>11. Input/Output 1 cable gland</li> <li>12. Keylock</li> </ol> |
|---|--|

### 3.4 Panel mount instrument

#### 3.4.1 Instrument dimensions

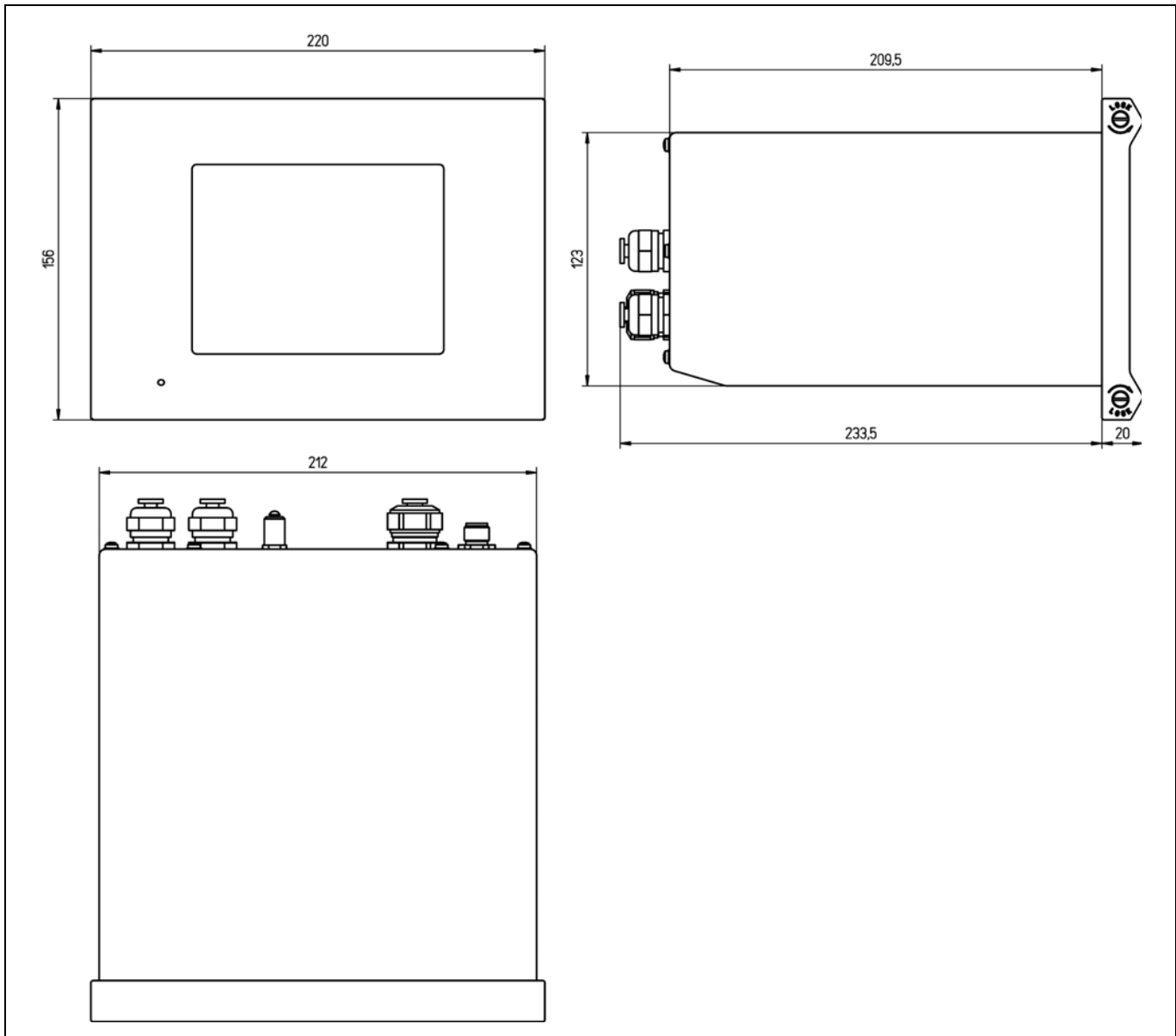
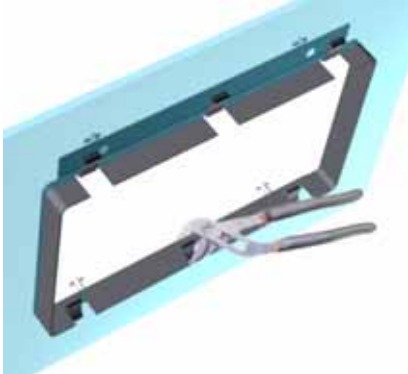
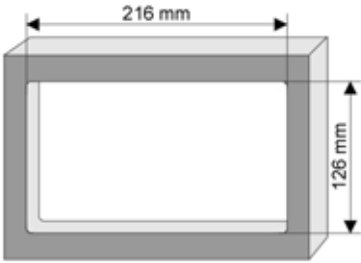
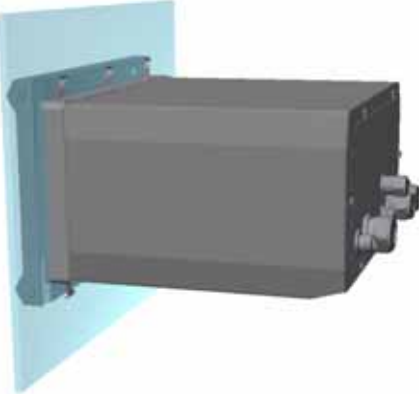
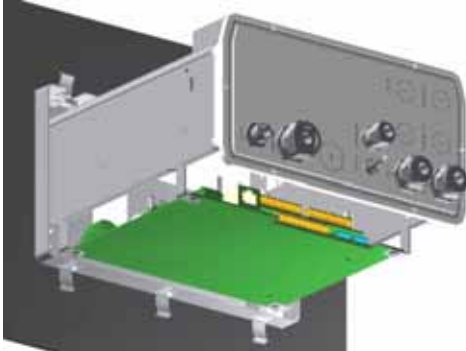

Figure 10 Panel mount instrument dimensions (in millimeters)

### 3.4.2 Mounting

 <p>Figure 11 Panel mount bracket frame</p>	<ol style="list-style-type: none"> <li>1. Cut an opening in the panel to accommodate the bracket frame provided (this is the same size as previous generations of ORBISPHERE type 3600 instruments).</li> </ol>  <p>Figure 12 Opening dimensions</p> <ol style="list-style-type: none"> <li>2. Install the provided frame in the opening</li> <li>3. Fold the 6 tabs over the panel lips, using adjustable joint pliers.</li> </ol>
	<ol style="list-style-type: none"> <li>4. Slide the instrument in the bracket frame. The instrument should go over the four "T" pins. Rotate the 4 fast locking screws on both sides of the front panel and slide it in.</li> <li>5. Rotate the 4 fast locking screws 1/4 turn twice in the lock direction as indicated on the side of the front panel. This locks the instrument in place on the four "T" pins.</li> </ol>
	<ol style="list-style-type: none"> <li>6. To access the connections inside the instrument, remove the instrument housing (six screws on the back panel, and slide the housing back out)</li> <li>7. Pass the cables through the housing, then through the cable gland (if applicable) and then perform the connections as detailed below.</li> </ol> <p><b>Note:</b> Do not forget to pass the cable through the housing before passing it through the cable gland on the back panel.</p>

## Alternative instrument mounting procedure

When it is not convenient to work from the back of the panel, the instrument can be connected before fitting in the panel.

1. Install the panel support frame in the panel opening
2. Slip the cables through the panel opening
3. Remove the instrument cover
4. Slip the cables through the instrument cover
5. Slip the cables through the instrument back panel cable glands
6. Connect the cables to the instrument electronic boards
7. Tighten the cable glands
8. Reinstall the instrument cover
9. Install the instrument in the panel opening

### 3.4.3 Connection panel (bottom of instrument)

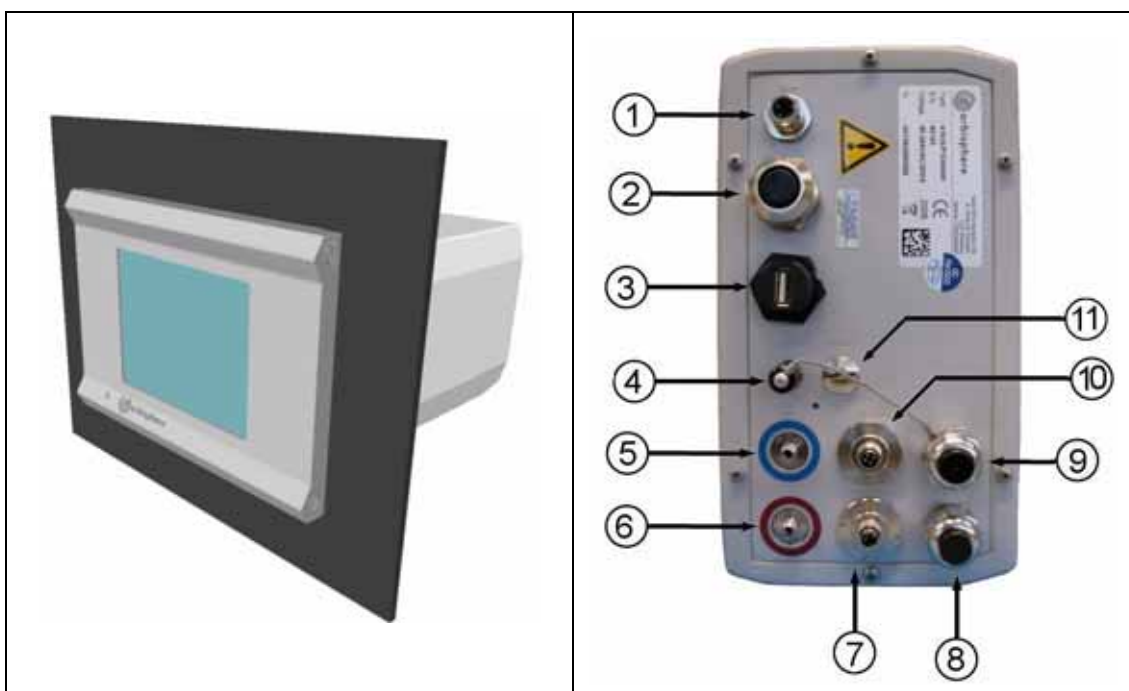

Figure 13 Panel mount connection panel

- |  |  |
|--|--|
| <ol style="list-style-type: none"> <li>1. Power cable. The type of connection will vary depending on the instrument specification (see <a href="#">Connection to mains power supply on page 30</a>)</li> <li>2. Ethernet cable gland</li> <li>3. USB-A host connector for mass storage device</li> <li>4. USB-B client 4 pin connector. Use the adapter cable (see <a href="#">USB-B client adapter cable on page 30</a>)</li> </ol> | <ol style="list-style-type: none"> <li>5. Sensor - blue cable connection</li> <li>6. Sensor - red cable connection</li> <li>7. Sensor - temperature connection (black cable)</li> <li>8. Input/Output 2 cable gland</li> <li>9. Input/Output 1 cable gland</li> <li>10. Flow chamber solenoid valve connection</li> <li>11. External pressure sensor connection</li> </ol> |
|--|--|

## 3.5 Connectors assembly instructions

### 3.5.1 Cable gland wiring instructions

A waterproof cable gland is provided each time a cable must be connected inside the instrument. The nickel-plated brass cable glands are EMC-types, designed so that the cable shields attach directly to the instrument housing as a ground. Typical cable wiring instructions are detailed below.

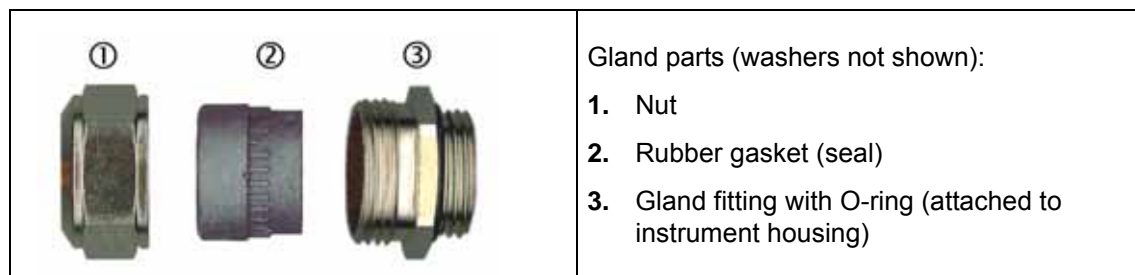

1. Unscrew the cable gland nut. Inside, the assembly is composed of a rubber gasket, and two metal washers. Note that the ethernet gland on panel and wall mount instruments does not have washers and the gasket is cut.
2. If wiring a sensor cable, the cable has already been prepared so simply remove the piece of plastic protection from the exposed shielding.

For other cables, strip off external insulation as required, and 25 mm of shielding. Strip the wires about 8 mm from their ends (see illustration below).

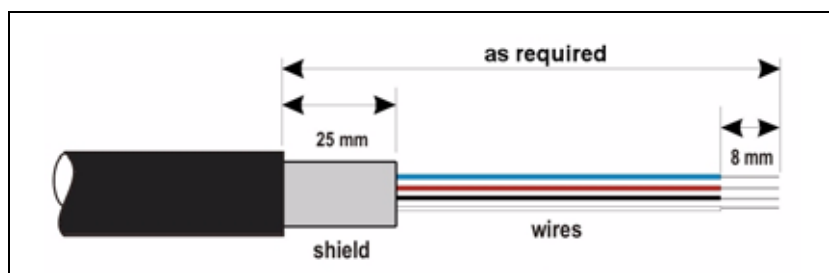

3. Pass the cable through the nut, the rubber gasket, and the two washers
4. Pinch the shield so that its entire circumference is pressed between the two washers and pass the cable into the housing, blocking the cable gland

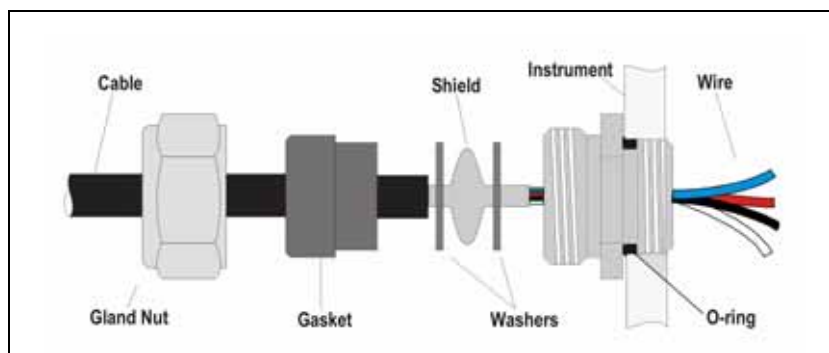

#### **CAUTION**

**It is vitally important to ensure the shielding is pinched and secured between the two washers to ensure the shielding attaches directly to the instrument housing as a ground. Failure to do this could cause damage to the instrument, and for sensor cables give incorrect readings.**

5. Reattach and tighten the cable gland nut
6. Attach the wires to the corresponding terminal block connections

## 3.5.2 USB-B client adapter cable

 <p data-bbox="395 595 778 629">Figure 14 USB-B adapter cable</p>	<p data-bbox="882 353 1414 416">This supplied cable is needed to connect the instrument to a PC.</p> <p data-bbox="882 434 1398 524">Connect to the instrument, and connect the USB connector to the USB outlet on the user's PC.</p>
--	---

## 3.6 Connection to mains power supply



### 3.6.1 Power supply connection (low voltage instruments)

For low voltage instruments (10-30 VDC), connection to the mains power supply for panel mount instruments is with an 8-pin FIXCON® connector (supplied). For wall mount instruments connection is with a 7-pin BINDER connector (supplied).

**Note:** The connectors are grooved to avoid an incorrect fitting to the instrument.

Connect the power cable to the connector as follows:

#### Panel mount instrument

 <p data-bbox="336 1216 874 1249">Figure 15 Panel mount FIXCON® connector</p>	<p data-bbox="919 1182 1142 1211"><b>Pin Connections:</b></p> <p data-bbox="919 1261 1262 1290">1 + 6 + 7) Power 10-30 VDC</p> <p data-bbox="919 1308 1134 1337">2 + 3 + 4) Ground</p> <p data-bbox="919 1355 1018 1384">8) Earth</p> <p data-bbox="919 1402 1046 1431">5) Unused</p> <p data-bbox="919 1449 1382 1512"><b>Note:</b> Bridge the power and ground pins to distribute load on three pins.</p>
	

#### Wall mount instrument

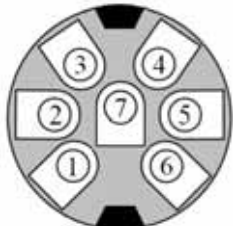
 <p data-bbox="355 1756 858 1789">Figure 16 Wall mount BINDER connector</p>	<p data-bbox="919 1727 1142 1756"><b>Pin Connections:</b></p> <p data-bbox="919 1805 1171 1834">2) Power 10-30 VDC</p> <p data-bbox="919 1852 1043 1881">5) Ground</p> <p data-bbox="919 1899 1018 1928">7) Earth</p> <p data-bbox="919 1946 1174 1975">1 + 3 + 4 + 6) Unused</p>
	



### 3.6.2 Power supply connection (high voltage instruments)

High voltage instruments (100-240 VAC) have a 4-pin male connector pre-wired internally with a male BINDER connector ready for mains connection. A compatible female connector is supplied with the instrument.

If this female connector was supplied with a mains power plug already pre-attached (cable part numbers 33031, 33032, 33033 and 33034) then the female connector can be plugged directly into the instrument power connector. The two connectors are grooved to avoid an incorrect fitting. Tighten the female connector to the instrument power connector finger-tight.

If no power cable was ordered with the equipment, a mains power plug must be connected to the supplied female connector as described in the following procedure.



**WARNING**

***If for any reason the mains power cable should become damaged at any time, it must be replaced exclusively by personnel specialized and authorized to work on electrical installations.***

User-supplied power cable specifications:

- 3-wire (live, neutral and earth)
- cable  $\varnothing \geq 7\text{mm}$ ;  $\leq 9.5\text{mm}$
- wire selection  $\geq 1\text{mm}^2$ , AWG18;  $\leq 2.5\text{mm}^2$ , AWG14



**WARNING**

***Before preparing the user-supplied cable and wiring the connector, ensure the cable is not connected to the mains power supply.***

Prepare the user-supplied power cable as follows:

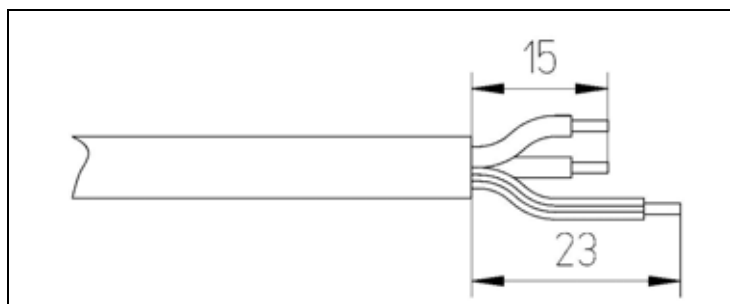

Strip off 23 mm (0.9 ins.) of shielding from the power cable. Cut back the live and neutral wires to 15 mm (0.6 ins.) in length but leave the earth wire as is. Then strip off a small amount of external insulation from the three wires as required:

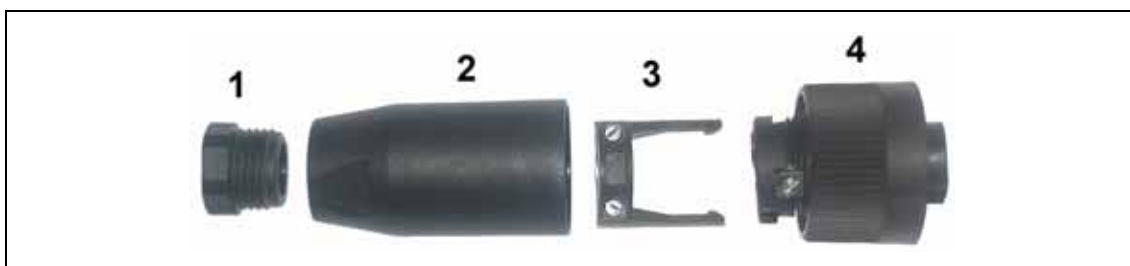

Wire the female connector as follows:

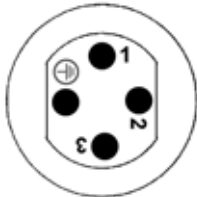

1. Take the narrow end of the connector (4) in one hand and the main body (2) in the other and unscrew the two. Pull away the cable clamp (3) and unscrew the end plug (1) to reveal the four parts that make up the connector.
2. Loosen the screws on the cable clamp (3) to allow enough room to pass the power cable through.
3. Pass the power cable through the end plug (1), the main body (2), and the cable clamp (3), and then connect the three wires (live, neutral and earth) to the connector (4) as follows:

	<p>1) Live (brown) 2) Neutral (blue) 3) Not used</p>  <p>Earth (green and yellow)</p>	<p><b>Note:</b> The numbers and earth symbol are stamped on the end of the connector. Ensure it is connected correctly.</p>
--	---	---

4. Slide the cable clamp (3) back onto the connector (4) and tighten the screws on the clamp to secure the cable.
5. Screw the two parts (4) and (2) back together.
6. Secure the power cable by screwing the end plug (1) back in place.
7. The female connector can now be plugged directly into the instrument power connector. The two connectors are grooved to avoid an incorrect fitting. Tighten the female connector to the instrument power connector finger-tight.



### 3.7 Connections to electronic boards

*Note: Any loose connection wires should be bundled tightly together with the use of nylon cable ties.*

#### 3.7.1 Electronic boards connectors

Connectors P8 on the main board, and connectors J7 and J8 on the measurement board are made of two parts. Push down carefully the black levers on either side of the connector and pull it out securely. Perform all connections with these connectors unplugged. Once finished, attach the connectors to the boards by pushing them firmly in place (levers up).

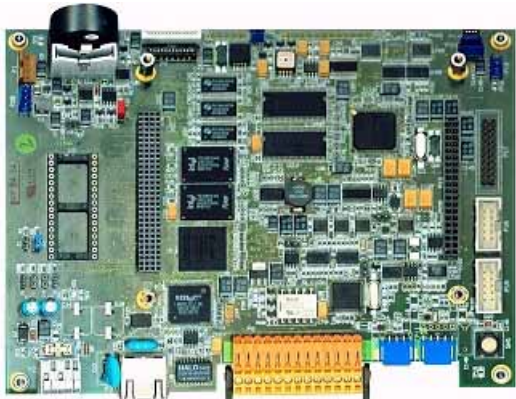
#### 3.7.2 Main board connections

 <p style="text-align: center;">P3                  P8</p> <p style="text-align: center;">Figure 17 Main board</p>	 <p style="text-align: center;">Figure 18 Connector P8</p>
	 <p style="text-align: center;">Figure 19 Connector P3</p>
<p><b>Connector P8:</b></p> <ol style="list-style-type: none"> <li>1. RS-485 (signal A)</li> <li>2. RS-485 (signal B)</li> <li>3. PROFIBUS-DP (GND)</li> <li>4. PROFIBUS-DP (+ 5 V)</li> <li>5. PROFIBUS-DP (signal -)</li> <li>6. PROFIBUS-DP (signal +)</li> <li>7. PROFIBUS-DP (signal RTS)</li> </ol>	<ol style="list-style-type: none"> <li>8. Not used</li> <li>9. Not used</li> <li>10. Not used</li> <li>11. System alarm relay (N.O.)</li> <li>12. System alarm relay (N.C.)</li> <li>13. System alarm relay (Common)</li> </ol>
<p><b>Connector P3</b>          Ethernet RJ 45. Connect the instrument to the local network by passing an ethernet cable through the ethernet cable gland (location illustrated in <a href="#">Figure 9 on page 25</a> for the wall mount and <a href="#">Figure 13 on page 28</a> for the panel mount). Connect to the P3 connector illustrated above.</p>	

### 3.7.3 Measurement board

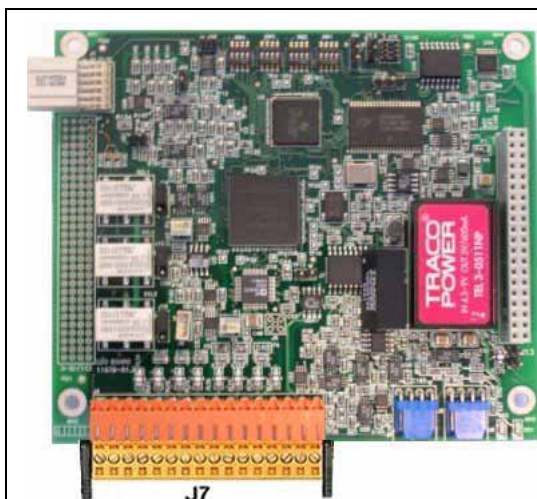

Figure 20 Measurement board

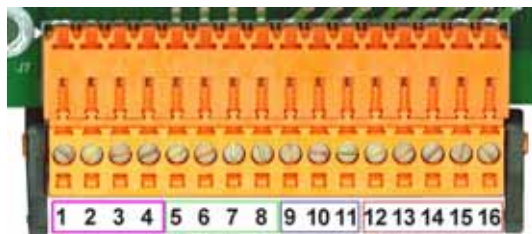

Figure 21 Connector J7

#### Connector J7 (inputs & outputs)

##### Measurement alarms relays

1. Common
2. Output relay 1
3. Output relay 2
4. Output relay 3

**Note:** Relays N.O. or N.C. depends on the jumper position on the relays (see [Measurement alarm relays on page 34](#)).

##### Analog current (or voltage) outputs

5. GND
6. Output 1
7. Output 2
8. Output 3

##### Digital inputs

9. to 16. Not used

### 3.8 Measurement alarm relays

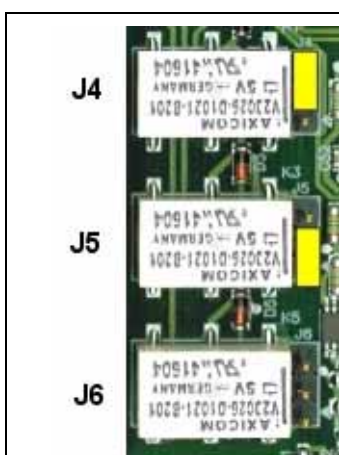

Figure 22 Output relays

The three output relays are located on the measurement board. When the instrument is delivered, all three of these relays are set to NO by default.

They can be individually configured to Normally Open (NO) or to Normally Closed (NC) by physically moving the jumper on each relay. On the picture example on the left:

- Upper relay is set to NC
- Middle relay is set to NO
- Lower relay is shown with no jumper, to show the 3 pins.

**Note:** J4 (upper relay) is relay 1  
 J5 (middle relay) is relay 2  
 J6 (lower relay) is relay 3

## 3.9 Sensor installation

### 3.9.1 Instrument connections

The sensor determines the dissolved oxygen concentration in a given water sample. The sensor spot is coated with a luminescent material. Blue light is then transmitted to the sensor surface and red light received in return. The cables through which this light is transmitted/received are color coded.

Ensure the correct colored cable is attached to the similarly colored connector on the instrument as illustrated in [Figure 23](#) below for the wall mount version of the instrument. The third sensor cable (temperature - colored black) is connected to the temperature socket.

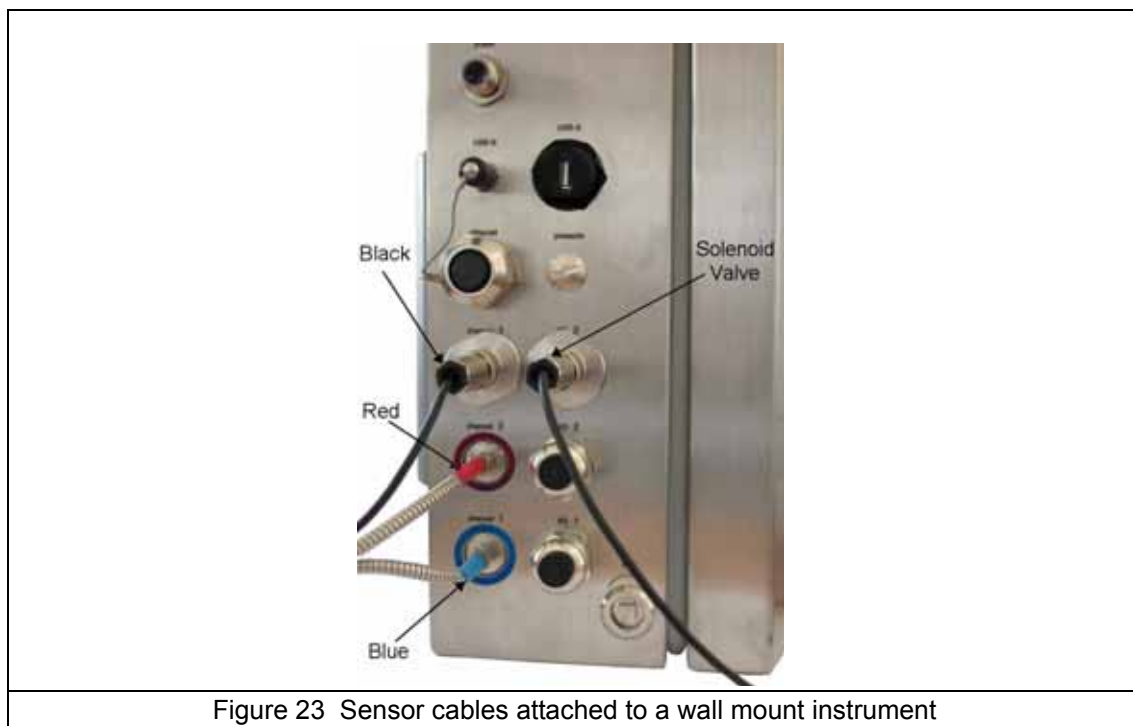

Figure 23 Sensor cables attached to a wall mount instrument

Refer also to the illustration of the connector panels in [Figure 9 on page 25](#) for the wall and pipe mount instruments and in [Figure 13 on page 28](#) for panel instruments.

## 3.9.2 Flow chamber

Attach the sensor to the specially designed flow chamber (illustrated in [Figure 24](#)). To do this, pull the sensor locking screw up (No. 9 in the illustration) and then gently position the sensor into the flow chamber. Push down on the locking screw and make a couple of turns until the sensor is secure. Then release the sensor and finger tighten the locking device to the flow chamber. Do not overtighten as this could damage the threads.

Next, ensure the solenoid valve is correctly connected to the instrument (as illustrated in [Figure 23](#) for the wall mount instrument). This valve is used to turn the sample flow off during calibration to allow the calibration gas to flow over the sensor surface.

Connect the sample flow to the sample inlet socket (6). The sample outlet (5) should go directly to drain/waste to avoid any back pressure during the sensor calibration process. For these connections, use a wrench to securely hold the nut attached to the flow chamber, and a second wrench to tighten the swagelock connector from the sample. Do **not** tighten the connector attached to the flow chamber.

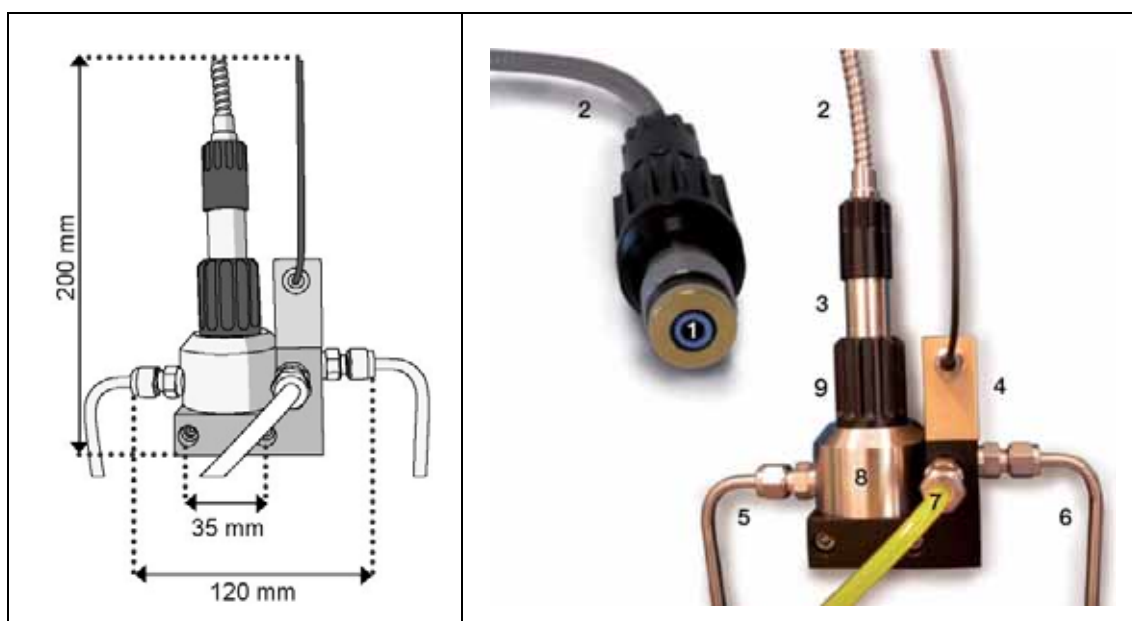
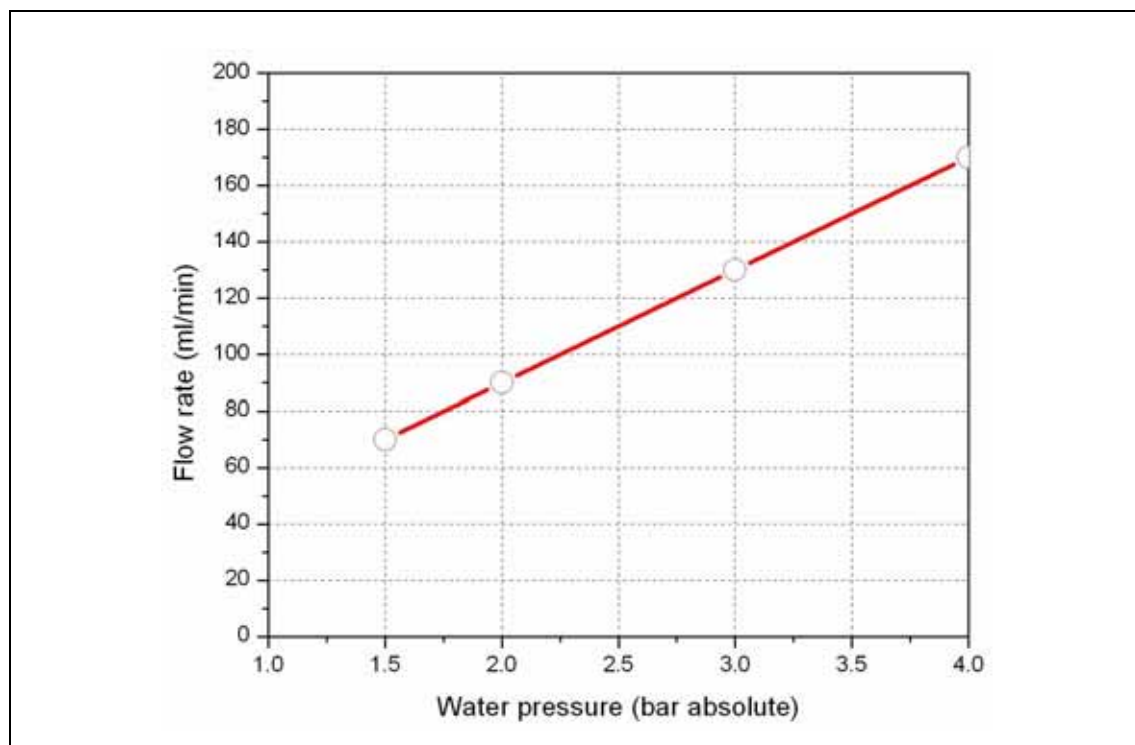

Figure 24 Flow chamber dimensions and components

1. Active luminescent spot	6. Sample inlet
2. Optical fiber cable	7. Calibration gas inlet
3. Sensor body	8. Flow chamber
4. Solenoid valve	9. Sensor locking screw
5. Sample outlet	

### 3.9.3 Flow rate

The flow rate is dependant on the water pressure in the sample flow line. The following graph illustrates the expected flow rate through the flow chamber after installation:



### 3.9.4 Calibration gas

<p>510</p> <p>33015</p> <p>Calibration gas bottle</p>	<p>A bottle of N<sub>2</sub> calibration gas should be connected to the flow chamber as illustrated left.</p> <p>Connect the bottle to the calibration gas inlet socket (7) with plastic tubing. Use the supplied pressure reducer (part number 33015) on the calibration bottle.</p> <p>Fully open the valve on the pressure reducer. Doing this will give the required calibration gas flow rate of 0.1 L/min.</p> <p>The bottle itself is not supplied and must be purchased locally. For accurate calibrations, the calibration gas bottles must be of 99.999% (50) quality or better, with a 5/8-18 UNF (C10) fitting. A minimum of 20 liters is required (34 is recommended), with a maximum of 70 bars.</p>
---	--





## Section 4 User Interface

### 4.1 Instrument

The instrument front panel provides these user interfaces:

- A touch screen acting as display, touch pad and keyboard. Contrast can be adjusted.
- A LED, showing when the instrument is on.
- A buzzer which sounds each time the screen is touched, and when an event alarm is set. Sound level and type can be adjusted.

#### Turning instrument On and Off

There is no power switch for the instruments. The mains must be disconnected to turn the instrument off. The LED indicates when the instrument is on.

#### Measurement window

The main (numeric) measurement window continuously displays:

- Sensor numeric values
- Measured sensor trends (for the last 1 minute to last hour)
- Measured sensor data alarm limits and other events
- Temperature value

### 4.2 Touch screen

The user interface on the front panel is a 320x240 pixels display with touch screen. To make navigation user friendly, the interface software is Windows CE based, providing easy selection through menus.

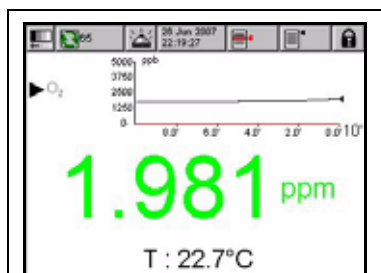



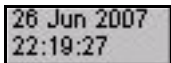
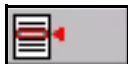



Figure 25 Numeric view

All the measurement, configuration, calibration and "standard service" routines can be called by pressing buttons and menu bars on screen.

The display can be configured to only show a single sensor measurement, or to show a parameterized graphic representation of the last measurements.

### 4.2.1 Function keys on the header bar

	<p>Shortcut to the user login window. Pressing this button for more than 2 seconds calls the ID and password window (see <a href="#">Identification and authorization level on page 42</a>).</p> <ul style="list-style-type: none"> <li>• Closed padlock indicates that the touch screen is locked.</li> <li>• Open padlock indicates that the instrument is in view mode only, but no user is logged in (level 0).</li> <li>• When a user is logged in, this box show the authorization level of this user as 1, 2, 3 or 4 (4 being the highest, see <a href="#">User management on page 90</a>).</li> </ul>
	<p>This icon is used for adjusting the display contrast to improve visibility. It is available all the time to any user, regardless of the user security level. This icon is a shortcut to the contrast adjustment window. See <a href="#">Screen on page 98</a></p>
	<p>Short cut to the data storage window. Number shows the number of measurement currently stored in volatile memory.</p> <ul style="list-style-type: none"> <li>• No storage</li> <li>• Store once: When the buffer is full (10,000 positions), the recording of measurement stops.</li> <li>• Rolling buffer: When the buffer is full, the latest measurement set replaces the oldest one (first-in, first-out)</li> </ul>
 <p>normal - snooze</p>	<p>In the event of an alarm, the "snooze" button stops the instrument buzzer and returns all the relays in the instrument to their normal state during the "snooze time". The icon indicates if the alarms is on "snooze" or not. This "snooze" is configurable (see <a href="#">Configure snooze on page 61</a>).</p>
	<p>Current date and time. This is also a shortcut to the date and time setting window.</p>
	<p>Call the contextual menu. This menu is in the header bar and its content is related to the view displayed.</p>
	<p>Opens the main menu page for easy navigation through all available menus.</p>

### 4.2.2 Menu navigation



	<p>Pressing the “menu” button in the header bar calls the main menu. The display is made of three columns:</p> <ul style="list-style-type: none"> <li>• The left column is the menus, or submenus (greyed out options are not available)</li> <li>• The center column shows a tree view of actual position inside the menu structure</li> <li>• The right column has the generic controls detailed below.</li> </ul>
---	--

Figure 26 Main menu window

	Return to previous menu (one step back)
	Jump directly to main menu
	Close the menu and go back to measurement view display. If the menu button is pressed again, the menu returns to its previous state (tree structure is saved)
	Help topics concerning current menu

### 4.2.3 Rolling list

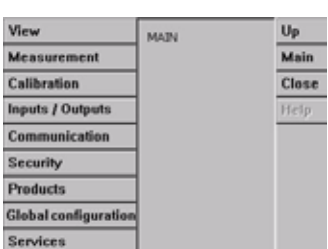
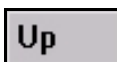
	<p>For convenience, selection through a possible large list of items has been designed with a rolling list, like in this example. Use the up and down arrow to navigate, or select directly one item and press <b>OK</b>.</p>
---	---

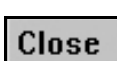
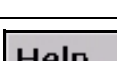
Figure 27 Rolling list example

### 4.2.4 Virtual keyboard

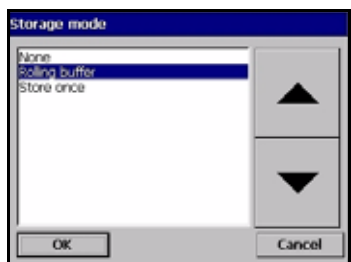

	<p>When a text box (alphanumeric field) has to be edited and is pressed, a virtual keyboard appears on screen. It can be used as a PC keyboard (pressing CAP gives access to special keys).</p> <p>Once values have been entered, press the <b>Enter</b> key to confirm and exit the virtual keyboard.</p> <p>During the editing, the edited field name is displayed, along with units where applicable.</p>
---	--

Figure 28 Virtual editing keyboard

### 4.2.5 Identification and authorization level

 <p>Figure 29 Identification window</p>	<p>Once the access rights have been set, (see <a href="#">User management on page 90</a>) it is necessary to log in as an authorized user to get access to the instrument functionalities and settings.</p> <p>Press the closed padlock  for two seconds to open the identification window. The user identification and password must be entered to access functionalities authorized by the security level of the given user (5 levels available. See <a href="#">User management on page 90</a>).</p> <p>For security, when the session inactivity delay period has expired (adjustable, via <a href="#">Configure security on page 90</a>), the user is logged off automatically.</p>
--	--

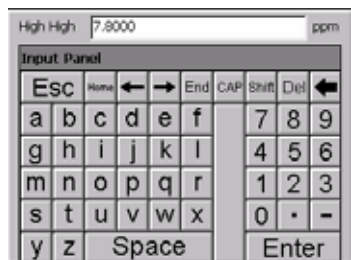
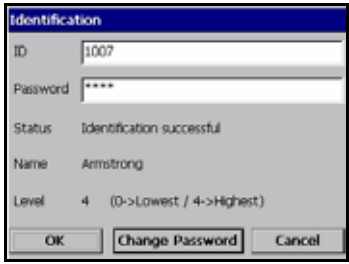
**Note:** To get to level 0, press the unlock button and OK, without entering any ID or password.

### 4.2.6 Warning windows

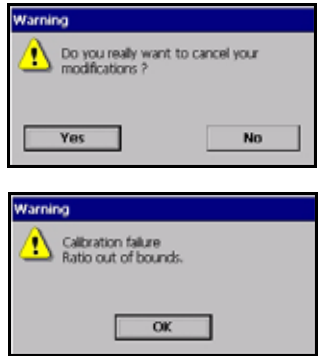
 <p>Figure 30 Warnings</p>	<p>At various stages, a warning message may be displayed to request confirmation from the operator that his last action(s) must really be saved or cleared, or that there is a problem that did not enable the requested action, such as during instrument calibration (example shown left).</p>
--	--

### 4.3 Main menu structure

This is the structure of the main menu which is used to control every functionality of the instrument. These submenus are detailed in the following sections of this Operator Manual.

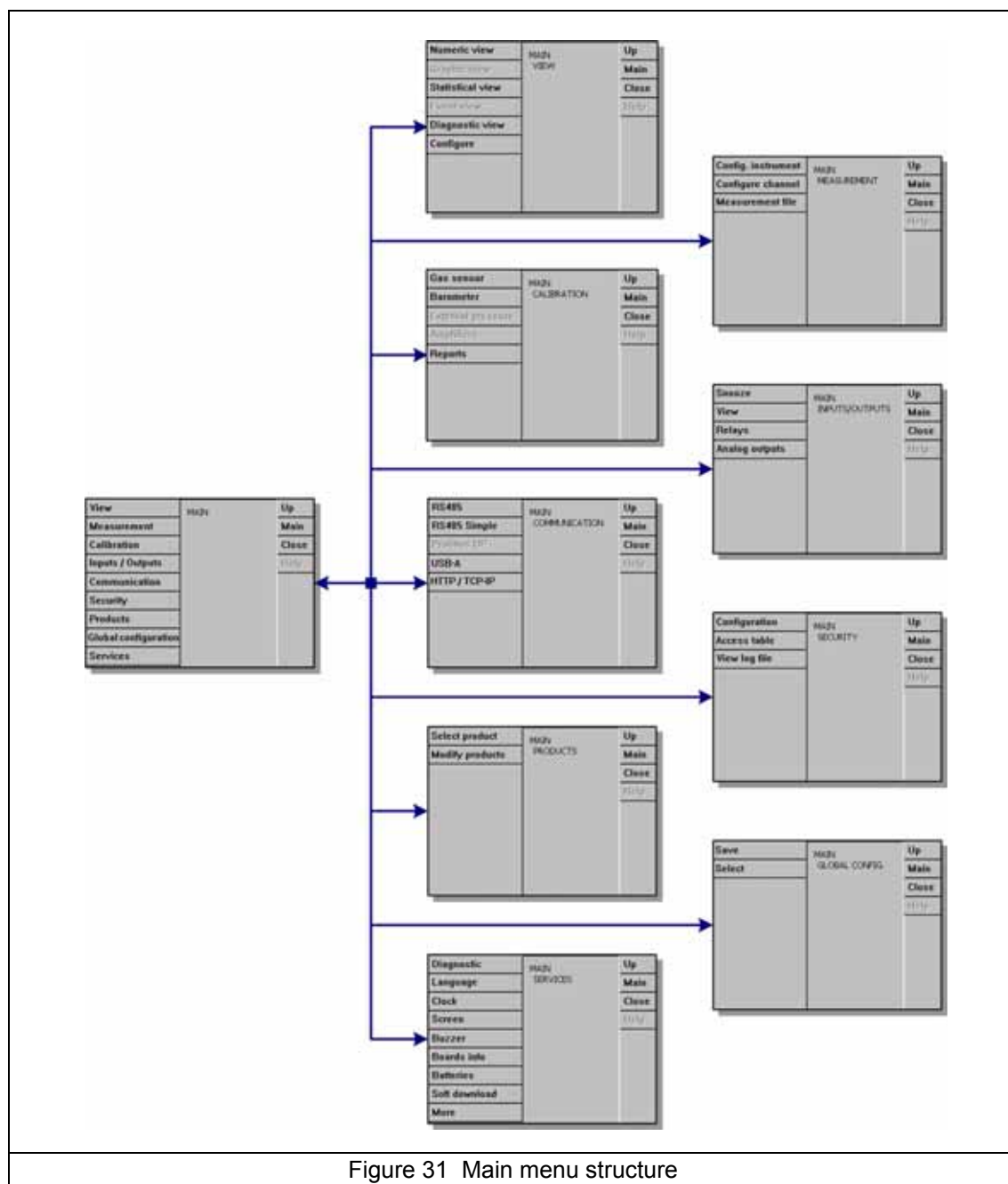

Figure 31 Main menu structure



# Section 5 View Menu

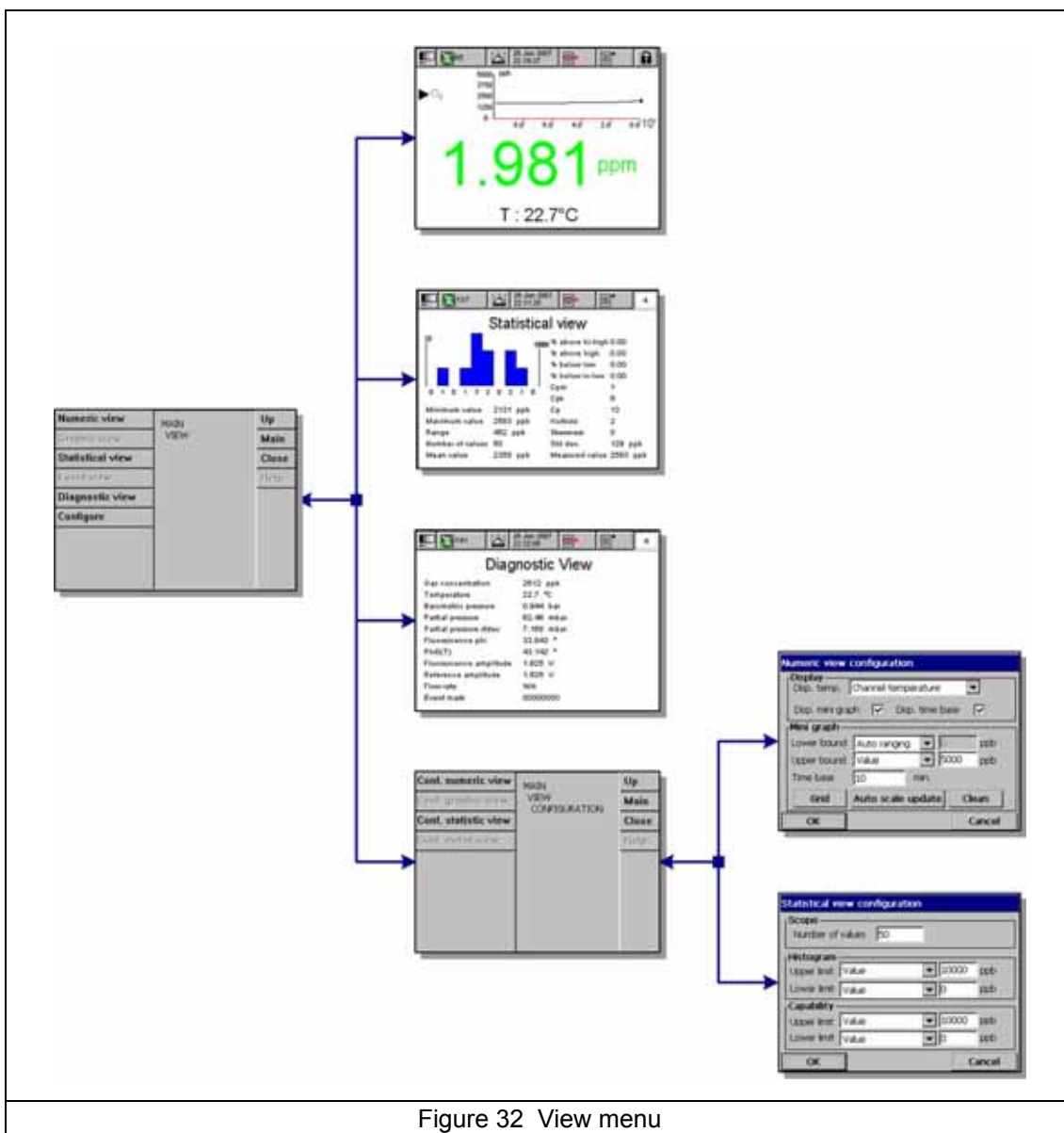
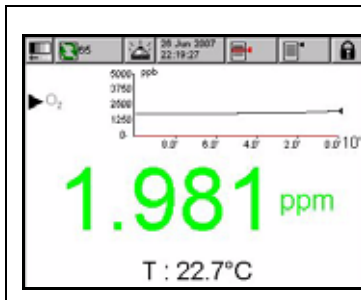

Figure 32 View menu

## 5.1 Selection of the view style

### 5.1.1 Numeric view



This is the default view: Display shows the numeric measurement value identified for the gas measurement channel, a graphic showing measurement value evolution during the set time frame, and sample temperature.

This display can be configured to suit individual conditions and convenience.

### 5.1.2 Diagnostic view

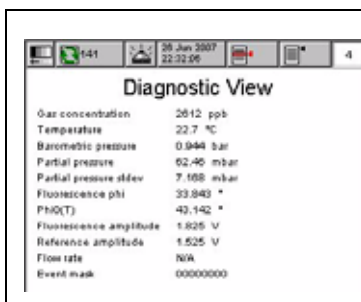

The diagnostic view contains useful information for troubleshooting purposes.

### 5.1.3 Statistic view

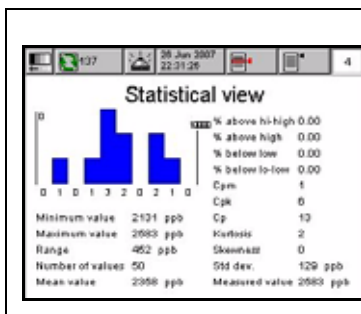

This feature offers statistical data that matches with Total Quality management tools. Statistics is a tool to better analyze how a process behave. The 510 statistics window gives some useful information.

The statistics are calculated from the data in the measurement file. The values are updated each time a new value is added to this file. Therefore the changes made in the configuration window are considered only once a new value is added.



**Cp process capability**

Cp is an index used to assess the width of the process spread in comparison to the width of the specification. It is calculated by dividing the allowable spread by the actual spread.

- A Cp of one indicates that the width of the process and the width of the specification are the same.
- A Cp of less than one indicates that the process spread is greater than the specification. This means that some of the data lies outside the specification.
- A Cp of greater than one indicates that the process spread is less than the width of the specification. Potentially this means that the process can fit inside the specification limits.

**CPk process variability**

Cpk takes into account the center of the data relative to the specifications, as well as the variation in the process.

- A Cpk value of one indicates that the tail of the distribution and the specification are an equal distance from the overall average.
- A Cpk of less than one means that some of the data is beyond the specification limit.
- A Cpk greater than one indicates that the data is within the specification.
- The larger the Cpk, the more central and within specification the data.

**CPm process repeatability**

Capability index that takes into account variation between the process average and the target. If the process average and the target are the same value, Cpm will be the same as Cpk. If the average drifts from the target, Cpm will be less than Cpk.

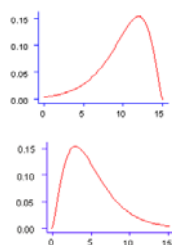

negative      positive

Figure 33 Skewness

**Skewness**

An asymmetric frequency distribution is skewed to the left if the lower tail is longer than the upper tail, and skewed to the right if the upper tail is longer than the lower tail. Distributions of positive-valued random variables values are often skewed right.

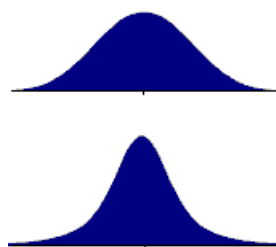

Figure 34 Kurtosis

**Kurtosis**

Kurtosis is a parameter that describes the shape of a random variable's probability distribution.

The graphs on the left illustrate the notion of kurtosis. The lower curve has higher kurtosis than the upper curve. It is more peaked at the center, and it has fatter tails

## 5.2 Configuration of the view styles

### 5.2.1 Numeric view configuration

List of parameters that can be adjusted to customize the numeric view display:

- Display temperature: no, channel temperature
- Display mini graph: yes/no
- Display time base: yes/no
- Upper bound: Adjust graph upper limit
- Lower bound: Adjust graph lower limit
- Time base: Adjust graph time span
- Grid button: Set up the graph to display the x or y axes, the grid, or the thresholds (see below)
- Auto Scale update: Automatically set the graph upper and lower bounds to best fit the actual values displayed.
- Clean button: Clear the slope displayed. The slope restarts from the left side.

### 5.2.2 Statistic view configuration

#### Scope:

- Number of values: Statistic calculation range (from 10 to 10,000 values). Number of values taken in consideration in the log file since the last value stored. The recorded values with alarms are not considered for calculation, but are part of the log file.

#### Histogram:

- Upper limit: Select High or High High alarm value, or a custom value.
- Lower limit: Select Low or Low Low alarm value, or a custom value.

#### Capability:

- Upper limit: Select High or High High alarm value, or a custom value.
- Lower limit: Select Low or Low Low alarm value, or a custom value.

# Section 6 Measurement Menu

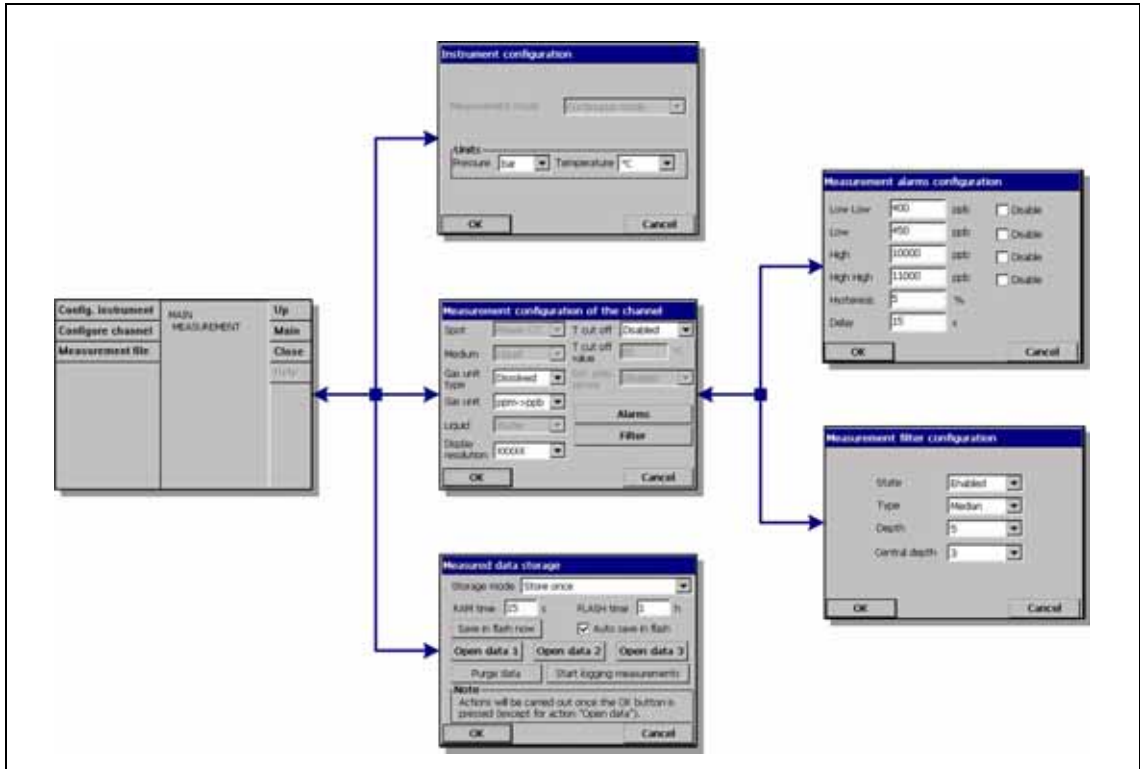

Figure 35 Measurement menu

## 6.1 Instrument configuration

### Continuous mode description

The continuous mode is typically used for process measurement, and follows this cycle:

- Every 2 sec. measurements are refreshed on the display
- The relays and the analog outputs are regularly updated
- Measurements are continuously stored in memory (volatile and non volatile memory)

	<ul style="list-style-type: none"> <li>• Measurement mode is locked on <b>Continuous</b> for on line process.</li> <li>• Selection of units for barometric, external pressure and temperature.</li> </ul>
--	---

## 6.2 Measurement configuration

	<ul style="list-style-type: none"> <li>• Sensor's spot selection</li> <li>• Medium: Liquid or gas phase.</li> <li>• Gas unit type: Partial, Fraction, Dissolved.</li> <li>• Gas unit: The list of available units depends on unit type selected above.</li> <li>• Liquid: When medium is liquid, select water or a liquid with a different solubility (if available).</li> </ul>
<p><b>Note:</b> When a composite unit is selected (e.g. ppm → ppb) the unit will change depending on the range of the value to display.</p>	
<ul style="list-style-type: none"> <li>• Display resolution: Maximum resolution depends on unit. A maximum of 5 digits can be displayed. Decimals can be limited to 0, 1, 2 or 3 decimals for easier reading. That does not affect the actual resolution of data measured and stored, but only the data displayed.</li> <li>• Thermal cutoff: This option is for information purposes only. It is possible to set a sample high temperature limit, which if exceeded causes the system to display a "HOT" alarm message. It is recommended, however, to disable this function.             <ul style="list-style-type: none"> <li>• Thermal cut off options: Disabled / enabled.</li> <li>• Thermal cut off temperature: To be set according to conditions.</li> </ul> </li> </ul>	

### 6.2.1 Measurement alarms configuration

	<p>Set the thresholds for the low/high concentration levels, according to the application. Each alarm type can be individually enabled or disabled without losing its settings.</p> <p>These events can activate the relays and can be displayed.</p>
--	---

- Low-low: 2nd stage for too low concentration
- Low: 1st stage for too low concentration
- High: 1st stage for too high concentration
- High-high: 2nd stage for too high concentration
- Hysteresis: A percentage of the above concentration values. The hysteresis is used to prevent relay "flickering" when the measurement is just at the alarm levels. Set this to a minimum, but enough to eliminate flickering.

As an example, if the High Alarm is set to 40 units and the Hysteresis is set to 10%, then the High Alarm is activated once the measurement reaches 40 units, but only deactivated once the measurement drops below 36 units. With the Low Alarm the opposite is true, in that if the Low Alarm is set to 20 units and the Hysteresis set to 10%, then the Low Alarm is activated when the measurement drops below 20 units, and deactivated when the measurement rises above 22 units.

- Delay: The delay in seconds, before alarms go on whenever concentration values go above "High alarms" or below "Low alarms". Set this to a minimum value, but enough to avoid alarms for non-representative peaks beyond the set level.

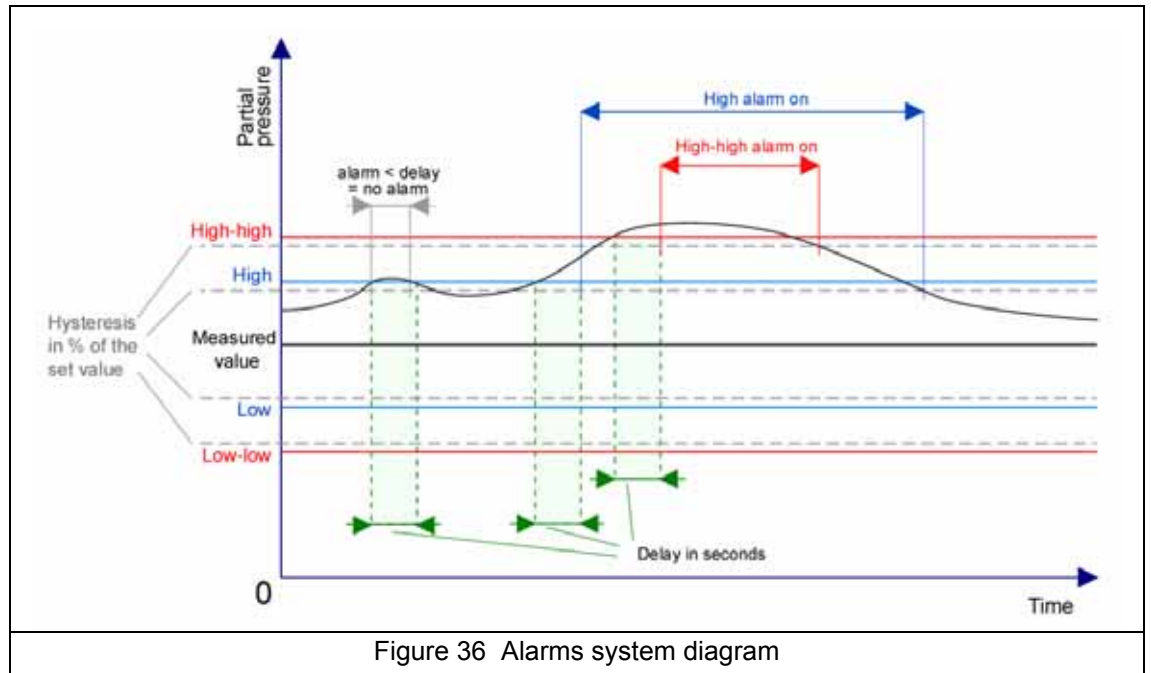

Figure 36 Alarms system diagram

### 6.2.2 Measurement filter configuration

	<p>The filters are aimed at “flattening” the measurement curve in situations where the process shows atypical peak values that could otherwise hamper the interpretation of measurement readings. The filter is applied on the last set of measurements each time a measurement is taken.</p> <ul style="list-style-type: none"> <li>• <u>Mean</u>: Mathematical average of the last set (depth) of measurement values.</li> <li>• <u>Median filter</u>: Allows for eliminating atypical peak measurement values, and average the remaining ones. The calculation sorts the last measurements set (depth) by values, then delete the highest and lowest values, and averages the remaining values (central depth).</li> </ul>
--	---

- Example for depth 7, central depth 5:  
Sorted values, both ends eliminated, the average of the center five is then 3.88.

0.7	1.1	4.0	4.3	4.4	5.6	7.0
-----	-----	-----	-----	-----	-----	-----

- Example for depth 5, central depth 3:  
Sorted values, both ends eliminated, the average of the center three is then 4.23.

1.1	4.0	4.3	4.4	5.6
-----	-----	-----	-----	-----

- Example for depth 8, central depth 4:  
Sorted values, both ends eliminated, the average of the center four is then 4.43.

0.7	1.1	4.0	4.3	4.4	5	5.6	7.0
-----	-----	-----	-----	-----	---	-----	-----

### 6.3 Measured data storage

There is one measurement file which contains the data generated by the measurement cycle. The measurement files are updated in volatile memory, and regularly copied in non-volatile memory (file back-up). At start up, the measurement files in volatile memory are updated with the files from the non-volatile memory.



This dialog box allows adjustment of the parameters for recording and storing measurements.

- Storage mode selection:
  - No storage
  - Store once: When the volatile memory is full (10,000 positions), the recording of measurement stops.
  - Rolling buffer: When the volatile memory is full, the latest measurement set replaces the oldest one continuously (first-in, first-out)

**Note:** Data stored in volatile memory are lost when instrument is off, non-volatile memory is permanent. In case of an accidental power off event, the instrument resumes measurement storage after the last measurement stored in flash.

- RAM time (volatile memory): Delay in seconds between two recordings of measured data.
- FLASH time (non-volatile memory): Delay in seconds between two data file transfers from volatile memory into non-volatile memory. The last data file erases the previous one. This field is only available if the Auto save in flash box is checked.
- Save in flash now: Press this button to store measurement data in flash (non-volatile memory) immediately. After pressing this button, press OK to initiate the process. A warning screen appears informing you that the operation can take up to 30 seconds. Press Yes to continue with the process, or No to abort.
- Auto save in flash: Check this box to save measurements in flash (non-volatile memory) automatically. Measurements are saved at regular time intervals as defined in the FLASH time box.
- Purge data: Clear all data for all channels in the volatile and non-volatile memories.
- Start logging measurement: Store once mode. Starts and stops the measurement recording session. Measurement recording is stopped when the buffer is full.

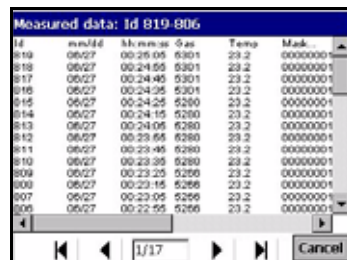

- Open data: Opens a table showing the measured values which are stored in the volatile memory (RAM).  
Use the scroll bar at the right to move to another data range (the id range will be shown in the title bar).  
The page number being viewed and the total number of pages are shown at the bottom (page 1 of 17 in the example left).  
Use the keys at the bottom to move directly to the first page, previous page, next page or last page.

# Section 7 Calibration Menu

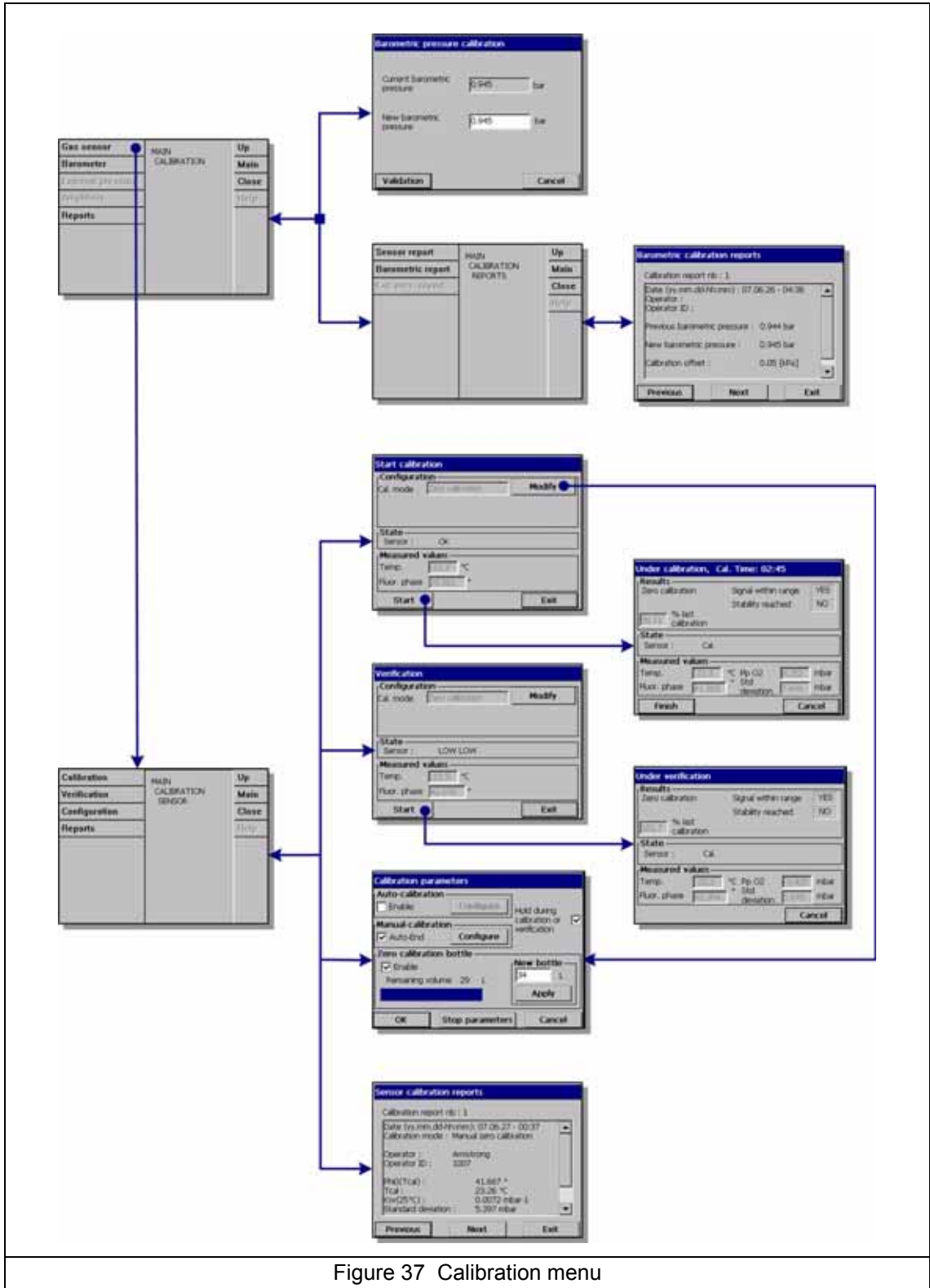

Figure 37 Calibration menu

Calibrations can only be performed once the instrument has been installed, configured, and the channel has been set up. You must also ensure that you have the correct access rights to access the calibration menu.

It is recommended to calibrate the sensor once a month.

The temperature sensor is factory calibrated and can only be changed by a Hach Lange representative.

### 7.1 Sensor calibration

The sensor can be calibrated either automatically at pre-defined intervals, or manually on an ad hoc basis. There are two calibration modes available - zero or high-level adjustment. The zero calibration method is the best calibration method to guarantee the sensor specifications. However, for higher level concentrations (such as 1% oxygen which corresponds to about 400 ppb dissolved O<sub>2</sub>) a high-level adjustment can be performed.

By default, the mode is set to zero calibration with auto-end (see [Calibration configuration on page 56](#) for more details), but these parameters can be changed.

Hach Lange recommends that the sensor be calibrated on an automatic basis at regular intervals.

**Note:** For zero calibrations, ensure a bottle of pure nitrogen gas is attached to the flow chamber as described in [Calibration gas on page 37](#) and with the specifications defined in that same chapter. If a 34 liter bottle is used, and calibrations are automated on a monthly basis, you should only have to change this bottle once every three years.

#### 7.1.1 Initial sensor calibration

After the instrument and sensor have been installed and configured, an initial calibration of the sensor must be performed. Before starting the calibration, wait at least 10 minutes with sample flowing through the system to ensure temperature equilibrium.

Select the **Configuration** option from the main sensor calibration menu to check the calibration parameters.

	<p>Ensure the parameters are set up to their default values as illustrated left:</p> <ul style="list-style-type: none"><li>• Auto-calibration: Off by default.</li><li>• Manual-calibration Auto-End: On by default.</li><li>• Hold during calibration or verification: On by default.</li><li>• Zero calibration bottle: On by default.</li><li>• New bottle: 34 liters by default. if using a different size bottle then update this parameter to reflect the size of the bottle and press <b>Apply</b>.</li></ul>
--	--

Exit from the configuration screen by pressing on **OK**. Then select **Calibration** from the main sensor calibration menu and perform a manual zero calibration as described in [Zero calibration on page 58](#).

After a successful calibration, return to the configuration option (illustrated above) and enable auto-calibration. Select the **Auto-calibration Configure** option and set the number of days between calibration to 30 (see [Configure automatic calibration on page 57](#) for details). This will ensure an automatic calibration cycle.

**Note:** There is no need to disable the manual calibration auto-end feature.



### 7.1.2 Automatic calibration

If automatic calibration is the preferred option, ensure that this has been set up and that the parameters are correct. See [Calibration configuration on page 56](#) for setting the calibration parameters.

When the calibration starts, the sample flow into the flow chamber is cut off automatically by the solenoid valve. Gas from the attached nitrogen gas bottle then flows through the flow chamber until measurements match the criteria set in **Stop parameters** or the time-out period of 10 minutes has elapsed.

Once the automatic calibration process is invoked, the message "Auto cal." will flash alternately with the measurement on the numeric view screen for the duration of the calibration.

When the stability criteria is reached, the calibration process stops automatically and the calibration parameters are updated. Normal sample measurement then resumes.

If the stability criteria is not reached within a 10 minute period, the sensor cannot be calibrated and the process is aborted. After the delay defined in **Stop parameters**, a second calibration is then attempted. If this second calibration also fails, then an Auto. Cal error event is activated. Normal sample measurement then resumes but the calibration parameters unchanged.

**Note:** *If a calibration is unsuccessful, no calibration report will be created. The report is only created with a successful calibration.*

### 7.1.3 Manual calibration

Manual calibrations can be made at any time, even if the auto-calibration parameter is enabled. See [Calibration configuration on page 56](#) for setting the calibration parameters, and [Zero calibration on page 58](#) or [High-level adjustment on page 58](#) for details of the different calibration methods.

## 7.2 Calibration configuration

This option can be invoked directly from the main calibration menu by selecting the **Configuration** option, or by pressing the **Modify** button in either the zero or high level calibration screens. The process sets all the parameters used for sensor calibration.

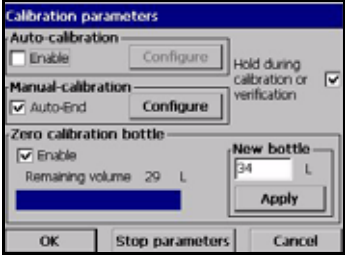
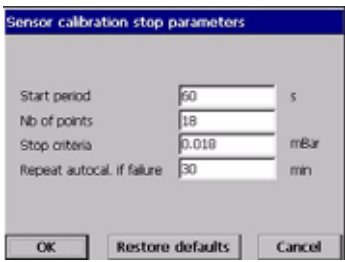
	<ul style="list-style-type: none"> <li>• Auto-calibration: Off by default. If enabled, press on <b>Configure</b> to set the auto calibration parameters (see <a href="#">Configure automatic calibration on page 57</a>).</li> <li>• Manual-calibration Auto-End: On by default. When enabled, a manual calibration will complete automatically when the parameters defined in <b>Stop parameters</b> are reached. Press on <b>Configure</b> to set the manual calibration parameters (see <a href="#">Configure manual calibration on page 57</a> for details). If the calibration fails, the previous calibration parameters remain unchanged and a warning message displayed.</li> <li>• Hold during calibration or verification: On by default. This keeps the last measured value and stops updating the outputs during the calibration or verification process. This avoids sending invalid information to any connected device. At the end of a calibration, this hold remains for a further 10 minutes to allow the system to stabilize.</li> <li>• Zero calibration bottle: On by default. This tracks the usage of gas from the gas bottle used in the zero calibration. The remaining volume is displayed as a value and usage bar. When 10% or less of the total volume remains, a warning alarm event is triggered and the bottle should be replaced. When replacing the bottle, use this option to enter the volume (in liters) of the new bottle and press <b>Apply</b> to update.</li> </ul>
	<p>If the <b>Stop parameters</b> button is pressed on the main configuration screen, you can view or change the existing values, or restore the default values.</p> <p>It is highly recommended to leave these parameters at their default values and not change them.</p> <p>These values apply to automatic calibrations and to manual calibrations with the <b>Auto-End</b> parameter set.</p> <ul style="list-style-type: none"> <li>• Start period: is the minimum time period that must elapse before measurements are considered valid</li> <li>• Number of points: is the minimum number of measurements that must be taken</li> <li>• Stop criteria: is the maximum allowable signal standard deviation value to ensure an accurate calibration.</li> <li>• Repeat autocal if failure: defines the time period that elapses before a second calibration attempt is made. A calibration failure event only occurs after the second failure.</li> </ul>

### 7.2.1 Configure automatic calibration

This option sets the parameters for the sensor to be zero calibrated at a regular interval. The sensor should be installed in the specially designed flow chamber (see [Sensor installation on page 35](#)) with a gas bottle of pure nitrogen attached.

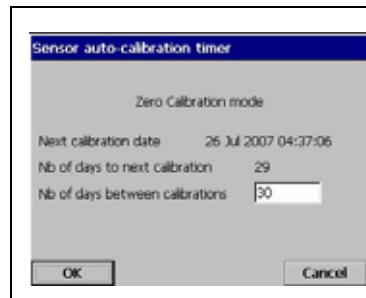

The calibration mode is set to zero calibration and cannot be changed.

Details of the next calibration date are displayed. If the next calibration date is overdue, the word **Missed** is displayed.

- Enter the number of days between calibrations (30 is recommended).

### 7.2.2 Configure manual calibration

This option sets the parameters required for manual sensor calibration.

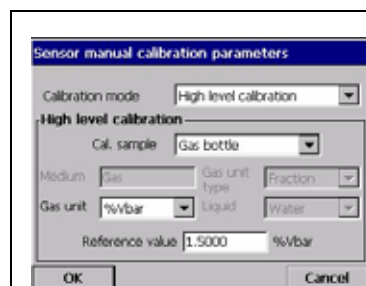

- Calibration mode: 2 types available:

- Zero calibration
- High level calibration

If zero calibration is selected, no other parameters are required to be set. However, the following parameters must be set if high level calibration has been selected.

- Calibration sample: Set to **in line sample**, **gas bottle** or **factory parameters**. If factory parameters is selected, the Ksv value is displayed (as illustrated left) but can be changed.

**Note:** The Ksv value should only need to be changed when replacing the sensor spot. The Ksv value of the new spot can be found on the 33029 kit box.

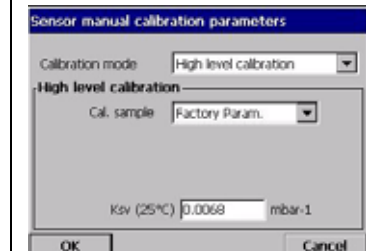

These additional parameters are required if in line sample or gas bottle has been selected as the calibration sample.

- Medium: This is automatically set to **liquid** if in line sample has been selected as the calibration sample, or **gas** if gas bottle has been selected.
- Gas unit type: Either **partial** or **dissolved** are available for an in line sample. If gas bottle was selected this is set to **fraction**.
- Gas unit: The list of available units depends on unit type selected above.
- Liquid: This defaults to **water**.
- Reference value: Enter the reference value for calibration

Press **OK** to return to the main calibration screen.

## 7.2.3 Zero calibration

	<p>With this method, the sensor should be exposed to pure N<sub>2</sub> gas using the specially designed flow chamber. Provided the sensor is attached to the flow chamber, this calibration method can also be automated (see <a href="#">Configure automatic calibration on page 57</a>).</p> <p>Press <b>Start</b> to start the calibration.</p>
	<p>A screen is displayed showing the measured values and length of time the sensor has been under calibration. These values are continually refreshed.</p> <p>The value <b>% last calibration</b> displayed in the top box is an informational message showing the difference between the current and previous sensor calibrations.</p> <p>The <b>Signal within range</b> and <b>Stability reached</b> boxes in the top right corner indicate whether the calibration is within acceptable limits. When both boxes indicate <b>YES</b>, press <b>Finish</b> to accept the new calibration. A confirmation screen then asks to accept and store the new parameters.</p> <p>If one or both boxes show <b>NO</b>, you can still perform a calibration but it is not recommended, and the calibration should be aborted by pressing the <b>Cancel</b> button.</p> <p>In the case of a calibration failure, attempt a second calibration after about 5 minutes. If the second attempt also fails, then refer to your Hach Lange representative for advice.</p> <p><b>Note:</b> If the Auto-End parameter is set (see <a href="#">Calibration configuration on page 56</a>), then the calibration will be deemed successful when the parameters defined in <b>Stop parameters</b> are met. You will then be asked to confirm the calibration.</p>
	<p>If you have not accepted or cancelled the calibration after an elapsed time of 10 minutes then the process will time-out, and the warning message illustrated left will be displayed.</p>

## 7.2.4 High-level adjustment

	<p>This calibration exposes the sensor to a gas or a liquid sample with a known gas concentration. You also have the option to reset the sensor's calibration parameters to factory settings (from drop-down list for <b>Cal. sample</b>).</p> <p>The screen example illustrated is for calibrating using a liquid sample. The screen for calibration using a gas bottle differs only slightly.</p> <p>Press <b>Start</b> to start the calibration. The process is then the same as for the zero calibration described previously.</p>
--	--

### 7.3 Sensor verification

	<p>Similar to the calibration procedure, but for verification of the actual calibration values. The results of the measurements made during the verification are not stored and the actual calibration data is not modified.</p>
--	--

### 7.4 Barometric pressure calibration

	<p><b>Note:</b> The barometric sensor has been factory calibrated but should be periodically verified with a precision certified barometer. This is only necessary if measuring in gas phase with fraction units (% , ppm).</p> <p>The upper box shows the barometric pressure as measured by the instrument.</p> <p>Using a precision certified barometer, measure barometric pressure in the location where the measuring instrument is used. Compare the values, if values are the same press <b>cancel</b>, otherwise enter the new barometric value in the lower box and <b>validate</b> the new setting.</p> <p>Once the calibration is completed a calibration report is generated.</p>
--	--

### 7.5 Calibration reports

Once a calibration is completed (for a gas or pressure sensor) successfully, the calibration report is updated with the new details. The calibration report contains data for the last 10 calibrations. The example illustrated below is for a gas sensor calibration. For full details on the data displayed for all calibration reports, refer to [Gas sensor calibration report example](#) and [Barometric sensor calibration report example](#) on page 76.

	<p>Each calibration record will contain parameters useful for traceability. For instance, it will contain:</p> <ul style="list-style-type: none"> <li>• the date and time</li> <li>• the calibration mode (zero or high level)</li> <li>• the calibration type (manual or automatic)</li> <li>• the operator name and ID</li> <li>• all the measurements which influence the calibration</li> </ul>
--	---



# Section 8 Inputs/Outputs Menu

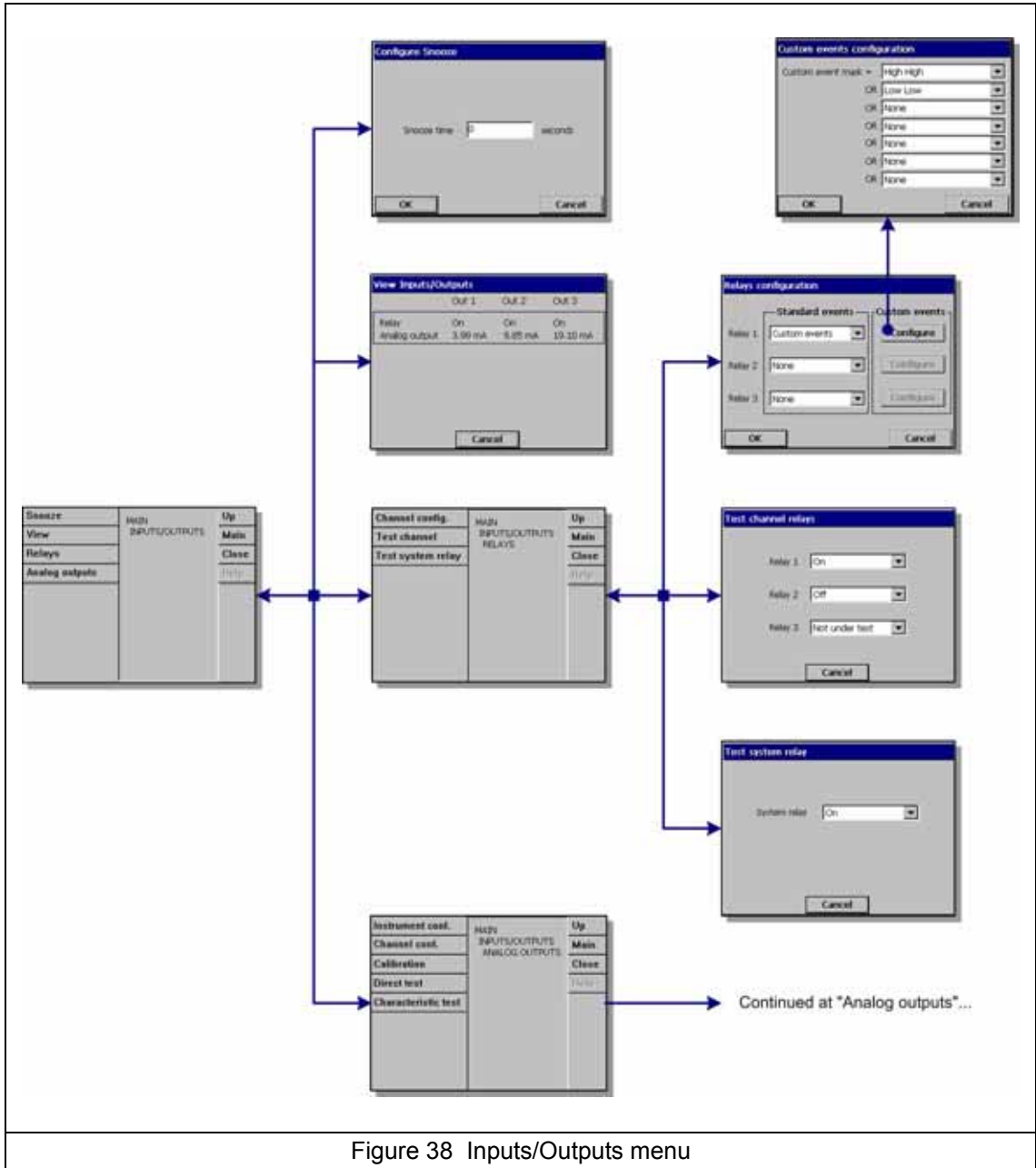
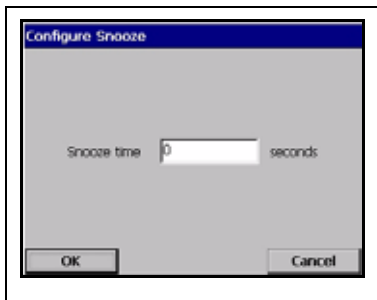

Figure 38 Inputs/Outputs menu

## 8.1 Configure snooze



In the event of an alarm, the “snooze” button stops the instrument buzzer and returns all the relays in the instrument to their normal state during a "snooze time".

- Enter the snooze time in seconds and press **OK**.

## 8.2 View inputs/outputs

	Out 1	Out 2	Out 3
Relay	On	On	On
Analog output	3.99 mA	9.85 mA	19.10 mA

For each channel, this view option displays the state of the 3 alarm relays (on or off), and the analog output current (or voltage, depending on the instrument version) value for each.

## 8.3 Relays

There are three measurement alarm relays and one system alarm relay. These relays are configurable as either standard or custom events through the instrument menu.

- An alarm relay can be activated or deactivated
- When the alarm is OFF, it is activated,
- When the alarm is ON, it is deactivated

All the relays are activated as soon as the instrument is ON (but alarms are OFF). When the instrument is OFF, the relays are deactivated, thus in this state, all alarms are ON. The logic "Relay deactivated = Alarm ON" has been chosen for this safety reason.

When the main board does not communicate with the measurement board for more than 30 seconds, the measurement board switches all the alarm relays and the analog output to the alarm state.

### 8.3.1 Relays configuration

	<p>The three measurement relays can be triggered by several standard events, or a combination of events (custom). The relays output can be used to turn on a beacon, horn or PLC (see <a href="#">Connections to electronic boards on page 33</a>)</p> <p><b>Note:</b> Relays can be set to Normally Open [NO] or Normally Closed [NC] by changing the jumper positions on the measurement board (see <a href="#">Measurement alarm relays on page 34</a>).</p>
	<ul style="list-style-type: none"> <li>• Select a standard event in the rolling list</li> <li>• If "Custom event" has been selected, it has to be configured by touching the <b>configure</b> button</li> </ul>



	<ul style="list-style-type: none"> <li>Press on the text box to open the selection menu (rolling menu). Select the events that must trigger the relay, and press <b>OK</b>.</li> </ul>
	<p>The example shown here will trigger the relays whenever the value is above the High High or under the Low Low preset values.</p>
<p>Proceed in the same manner for other event that should trigger the relay.</p>	

### 8.3.2 Test channel relays

	<p>The three measurement alarm relays can be manually activated for testing purposes:</p>
<ul style="list-style-type: none"> <li>Select Relay <b>On</b>, <b>Off</b> or <b>Not under test</b>.</li> </ul>	
<p>See note regarding the relays below. “Not under test” means the relay is in operating mode, and it will be triggered normally.</p>	
<p><b>Note:</b> A relay set to NO will close when activated (<b>On</b>), but a relay set to NC will open. See <a href="#">Measurement alarm relays on page 34</a></p>	

### 8.3.3 Test system relay

	<p>Similarly, the system alarm relay can be manually activated for testing purpose.</p>
<ul style="list-style-type: none"> <li>Select Relay <b>On</b>, <b>Off</b> or <b>Not under test</b>.</li> </ul>	

**Note:** In both the Test Channel Relays and Test System Relay options above, once the tests have been completed press **Cancel** to exit the screen. At the same time, this will reset all relays (including the system relay) back to a status of “Not under test”.

## 8.4 Analog outputs

There are three analog outputs. These outputs are configurable in terms of function, content, and behavior through the instrument menus. Analog outputs are used to output a voltage or a current which is a function (e.g. a linear characteristic) of a measurement:  $AOut = f(M)$ . The analog outputs can be typically connected to a PLC. Knowing the function ( $f$ ), the PLC can compute the value of the measurement.

Two types of instrument hardware are available:

- measurement board with current output ( $I = 0-20 \text{ mA}$  or  $4-20 \text{ mA}$ ).
- measurement board with voltage output ( $U = 0-5 \text{ V}$ ).

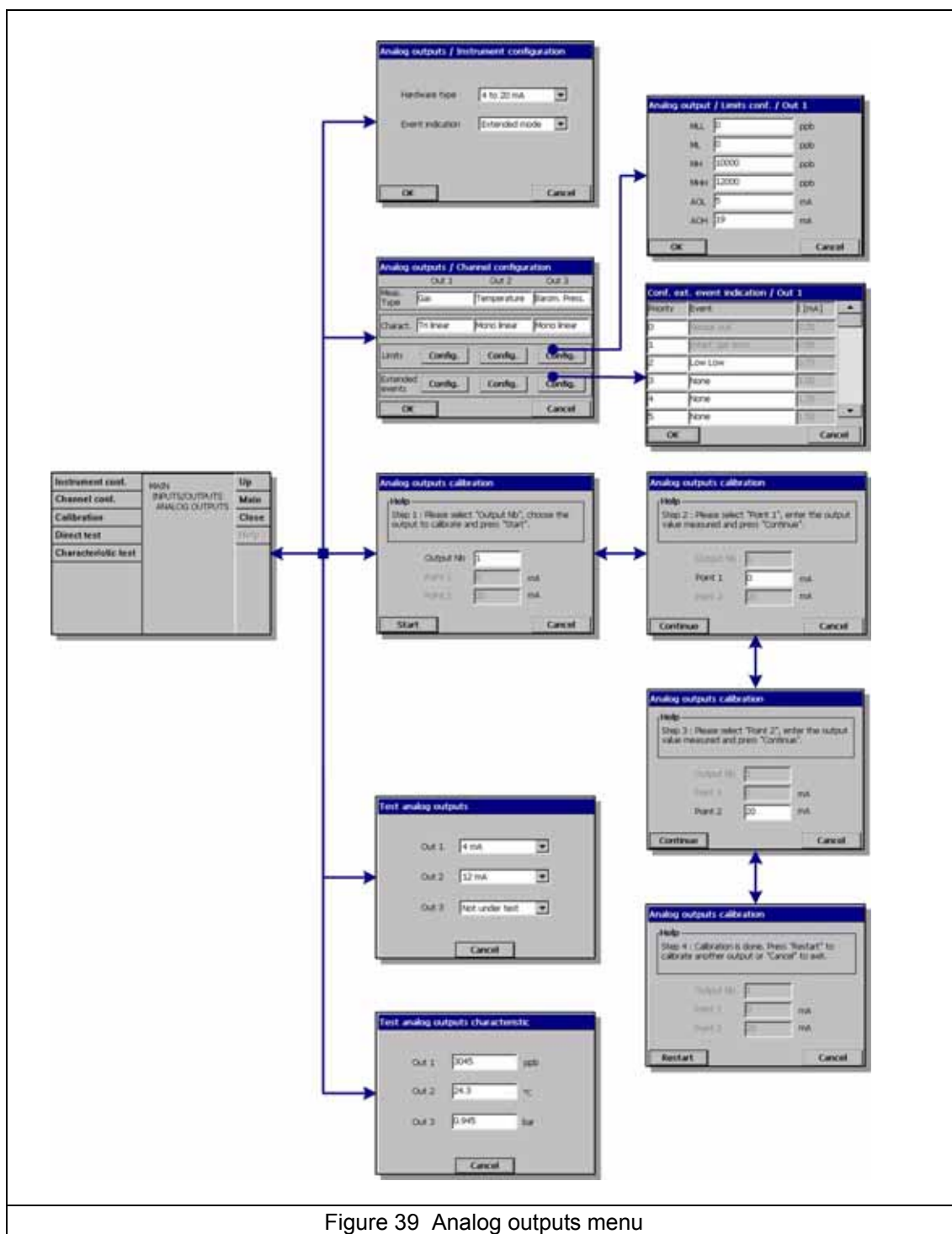
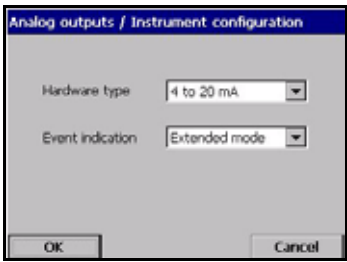

Figure 39 Analog outputs menu

### 8.4.1 Instrument configuration

	<ul style="list-style-type: none"> <li>• Select analog output range of current: 4-20 mA or 0-20 mA</li> <li>• The 4-20 mA range (recommended) allows for an extended event indication mode that can be selected and configured (default = standard mode)</li> </ul> <p><b>Note:</b> Features of the instrument with a voltage analog output are similar to the 0-20 mA features.</p>
---	--

For some events (sensor out, purge failure, etc.) the actual measurement is not significant, but the PLC needs to know how the analog output behaves in these cases. Two "Event indication modes" are available:

- Standard mode (default)
- Extended mode

#### Standard event indication

Analog output	Event output range			Event
	0-20 mA	4-20 mA	0/5 V	
Gas concentration	20 mA	20 mA	5 V	<ul style="list-style-type: none"> <li>• Channel out</li> <li>• Sensor out</li> <li>• Thermal cut-off</li> <li>• Interfering gas error</li> </ul>
Temperature	20 mA	20 mA	5 V	<ul style="list-style-type: none"> <li>• Channel out</li> <li>• Sensor out</li> </ul>

#### Extended event indication

The "Extended event indication" mode is only available when the 4-20 mA output is selected. In this mode, the range between 0 mA and 4 mA is used to indicate selected events. The events are defined using the channel configuration option (see [Channel configuration on page 66](#)).

**Note:** The extended mode is not available for the voltage output versions of the instrument.

## 8.4.2 Channel configuration

	<p>Set the type of measurement that will be transmitted through this channel, and the output characteristics.</p> <ul style="list-style-type: none"> <li>• Meas. type: Select between the type of measurements available in the rolling list.</li> <li>• Characteristics: Select either Linear, Tri-linear or None (see <a href="#">Analog output characteristics on page 69</a>)</li> </ul>
	<ul style="list-style-type: none"> <li>• Limits: Press the configure button to adjust the analog output set points for each output. Enter values in the appropriate text boxes. In Linear mode, only the ML and MH values can be adjusted. Tri linear mode allows all limits to be adjusted, and the None mode denies access to this screen.</li> </ul>
	<p>The authorized user may define a maximum of 12 customized events for each analog output and change the order of priority of all events.</p> <p><b>Note:</b> This only applies to Tri linear and Linear outputs. It is not available if the output characteristic is set to None.</p> <p>Configure the events that should be signaled at the corresponding current shown in the right column.</p> <ul style="list-style-type: none"> <li>• Only one event signal at a time can be sent via the current output. As there is a possibility to have several events at the same time, an order of priority must be set. This order has been set by default, but it can be modified to suit particular needs and conditions. Touch the priority number in the left column and edit it.</li> <li>• The shaded events in the list have preset outputs and only the priority can be changed. The other events can be customized by the user. Touch a white text box to call up the rolling list. Select an event from this list and press <b>OK</b>. Then adjust the priority as required.</li> </ul>
<p><b>Note:</b> When an event occurs, measurement information is superseded by the event information on the output.</p>	

The following table lists the default configuration. The first two events on the list are pre-set and only the priority can be changed:

Table 1 Extended event table		
Priority	Event	I [mA]
0	Sensor out	0.25
1	Interfering gas error	0.50
2	Custom Event 1	0.75
3	Custom Event 2	1.00
4	Custom Event 3	1.25
5	Custom Event 4	1.50
6	Custom Event 5	1.75
7	Custom Event 6	2.00
8	Custom Event 7	2.25
9	Custom Event 8	2.50
10	Custom Event 9	2.75
11	Custom Event 10	3.00
12	Custom Event 11	3.25
13	Custom Event 12	3.50
14	Custom Event 13	3.75

### 8.4.3 Calibration of the analog output

The calibration of the analog output is aimed at aligning the internally calculated current to the real current output. This was performed at factory, but could become necessary again because of electronic tolerances. A precision amperometer (or voltmeter for the voltage versions) connected at the corresponding analog output connection point is required. See [Measurement board on page 34](#).

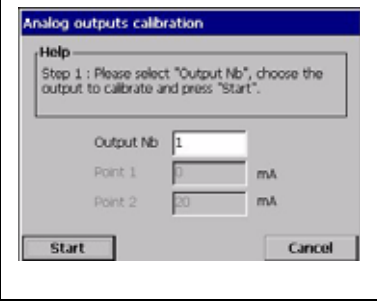
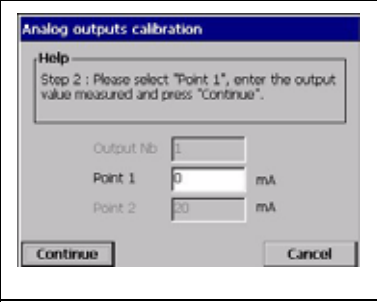
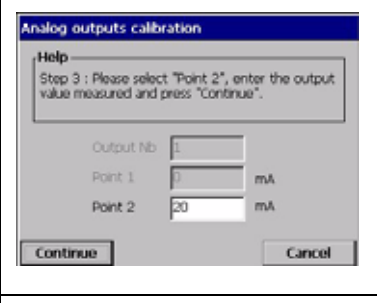
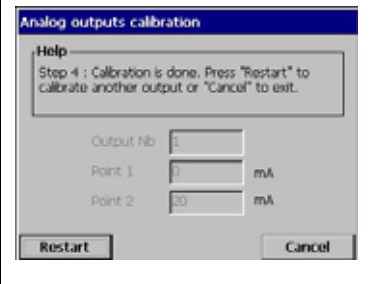
	<p>Select the analog output channel to calibrate and press the <b>Start</b> button.</p>
	<p>Measure with the amperometer the current value for point 1. It should be below 4 mA Edit point 1 and enter the same value as read on the amperometer, then press the <b>Continue</b> button.</p>
	<p>Measure with the amperometer the current value for point 2. It should be above 20 mA. Edit point 2 and enter the same value as read on the amperometer, before pressing the <b>Continue</b> button.</p>
	<p>Calibration of the selected analog output channel is completed. Proceed in the same way for the other analog output channels available.</p>

### 8.4.4 Direct test

	<p>Test to check the calibration of the analog outputs. A precision amperometer connected at the analog output connection point is required.</p> <ul style="list-style-type: none"> <li>Select a value (4, 12, 20 mA available) for each channel and compare this value (<math>\pm 0.02</math> mA) with what the amperometer shows.</li> </ul> <p>A calibration is required if the value on the amperometer differs from the current selected <math>\pm 0.02</math> mA).</p>
--	--

*Note: It is possible to test one analog output without interfering with the others. During the test, the other analog outputs will continue to indicate the measurement.*

### 8.4.5 Characteristics test

	<p>This is a test for the correct operation of the peripherals connected to each analog output, by verifying that the PLC computes the correct value.</p> <p>The analog output will send the current corresponding to the value entered in the text boxes.</p> <ul style="list-style-type: none"> <li>Type in a test value for each analog output, and check for the related action on the peripheral.</li> </ul>
--	---

## 8.5 Analog output characteristics

### 8.5.1 “Linear” analog output

The "Linear" output is the default setting for the analog output. It is illustrated in [Figure 40](#) below (4-20 mA output is shown, 0-20 mA or 0-5 V settings are similar).

The goal of this setting is to use all the points available on the slope from 4 mA to 20 mA to show the range of measurements that are usual in the measured process. Setting the output this way allows for the highest signal resolution for the actual conditions.

The downside is that any measures below the set range will have the same analog signal locked at 4 mA. Similarly, any measure over the set range will have the same analog signal locked at 20 mA. Settings must be made in balancing these aspects.

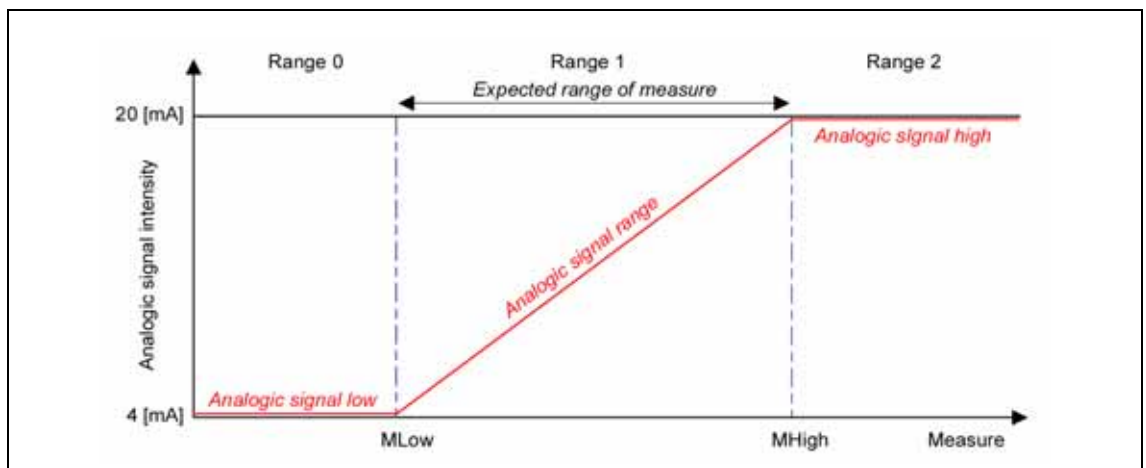

Figure 40 “Linear” characteristics diagram

## Settings

For the output, set ML and MH in the current measuring unit (e.g. °C for a temperature output). When a compound unit is selected the smallest unit will be used (e.g. ppb for a "ppm-ppb" compound unit).

These points should be set keeping in balance the following conditions (see [Figure 40](#)):

- The smaller is Range 1, the better is the analog signal resolution within the expected range of measure.
- In Range 0 the analog output only shows that measurement is below the ML value. Similarly in Range 2 the analog output only shows that measurement is over the MH value.

The formula to compute the measurement knowing the current I (or voltage U) and the resolution R is given in the following table:

Linear	Range	Measurement M	Resolution R
4-20 mA	$20 > I > 4$	$M = ML + (MH - ML) \cdot (I - 4) / 16$	$R = (MH - ML) / 808$
0-20 mA	$20 > I > 0$	$M = ML + (MH - ML) \cdot I / 20$	$R = (MH - ML) / 1010$
0 - 5 V	$5 > U > 0$	$M = ML + (MH - ML) \cdot U / 5$	$R = (MH - ML) / 1010$

## 8.5.2 "Tri-linear" analog output

The "Tri-linear" output brings benefits over the "Linear output" discussed before. It is illustrated in [Figure 41](#) below (4-20 mA output is shown, 0-20 mA or 0-5 V settings are similar).

Compared to the "Linear" mode, the expected range of measure is Range 2. A Range 1 and 3 are available to show the measures falling out of this Range 2, but normally at a lower resolution. Expected measurements for the measured process are supposed to be in Range 2 most of the time, and in Range 1 or 3 occasionally (problems, calibration, line stop, etc.).

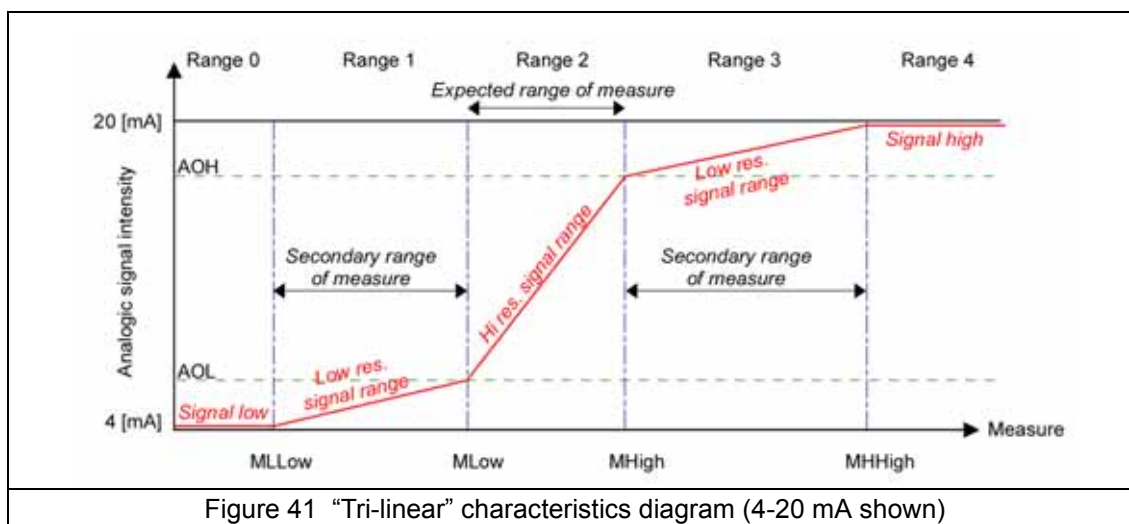

The benefits are:

- The PLC can compute the measurement over a large range (1, 2 and 3).
- The PLC can compute a higher resolution signal for the expected measuring range (Range 2:  $MH > M > ML$ ).
- Carefully selecting the set points allows for an individual resolution for each range, so a different resolution can be applied to Range 1, 2 and 3, allowing to tailor the analog output to the actual conditions.

As before, the downside is that any measure below or over the Range 1, 2 and 3 will have the same signal locked at 4 mA and 20 mA respectively, but Range 1, 2 and 3 should cover a larger range than in the "Linear" mode. Settings must be made in balancing these aspects.



**Settings**

For each output, set MLL, ML, MH, and MHH in the current measuring unit (e.g. °C for a temperature output). When a compound unit is selected, the smallest unit will be used (e.g. ppb for a "ppm-ppb" compound unit). Also set AOL (Analog Output Low) and AOH (High) in mA (or Volts).

These points should be set keeping in balance the following conditions (see [Figure 41](#)):

- The smaller is Range 2, the better is the analog signal resolution within the expected range of measure.
- Size of Range 1 and 3 should be set to deliver an adequate level of resolution for the measures falling out of the expected range of measure.
- In Range 0 the analog outputs only shows that measurement is below the MLL value. Similarly in Range 4 the analog output only shows that measurement is over the MHH value.

The formula to compute the measurement knowing the current or the voltage and the resolution R is given in the following table:

Tri-linear	Range	Measurement M	Resolution R
4-20 mA	1: $AOL \geq I > 4$	$M = MLL + (ML - MLL) \cdot (I - 4) / (AOL - 4)$	$R = (ML - MLL) \cdot 20 / ((AOL - 4) \cdot 1010)$
	2: $AOH \geq I > AOL$	$M = ML + (MH - ML) \cdot (I - AOL) / (AOH - AOL)$	$R = (MH - ML) \cdot 20 / ((AOH - AOL) \cdot 1010)$
	3: $20 > I > AOH$	$M = MH + (MHH - MH) \cdot (I - AOH) / (20 - AOH)$	$R = (MHH - MH) \cdot 20 / ((20 - AOH) \cdot 1010)$
0-20 mA	1: $AOL \geq I > 0$	$M = MLL + (ML - MLL) \cdot I / AOL$	$R = (ML - MLL) \cdot 20 / (AOL \cdot 1010)$
	2: $AOH \geq I > AOL$	$M = ML + (MH - ML) \cdot (I - AOL) / (AOH - AOL)$	$R = (MH - ML) \cdot 20 / ((AOH - AOL) \cdot 1010)$
	3: $20 > I > AOH$	$M = MH + (MHH - MH) \cdot (I - AOH) / (20 - AOH)$	$R = (MHH - MH) \cdot 20 / ((20 - AOH) \cdot 1010)$
0-5 V	1: $AOL \geq U > 0$	$M = MLL + (ML - MLL) \cdot U / AOL$	$R = (ML - MLL) \cdot 5 / (AOL \cdot 1010)$
	2: $AOH \geq U > AOL$	$M = ML + (MH - ML) \cdot (U - AOL) / (AOH - AOL)$	$R = (MH - ML) \cdot 5 / ((AOH - AOL) \cdot 1010)$
	3: $5 > U > AOH$	$M = MH + (MHH - MH) \cdot (U - AOH) / (5 - AOH)$	$R = (MHH - MH) \cdot 5 / ((5 - AOH) \cdot 1010)$

**8.5.3 None**

This is the default value.

Setting the analog output to “None” means that the output value will always be zero and importantly ensures that no current is emitted on that output, so reducing power consumption as well as reducing heat within the instrument.



# Section 9 Communication Menu

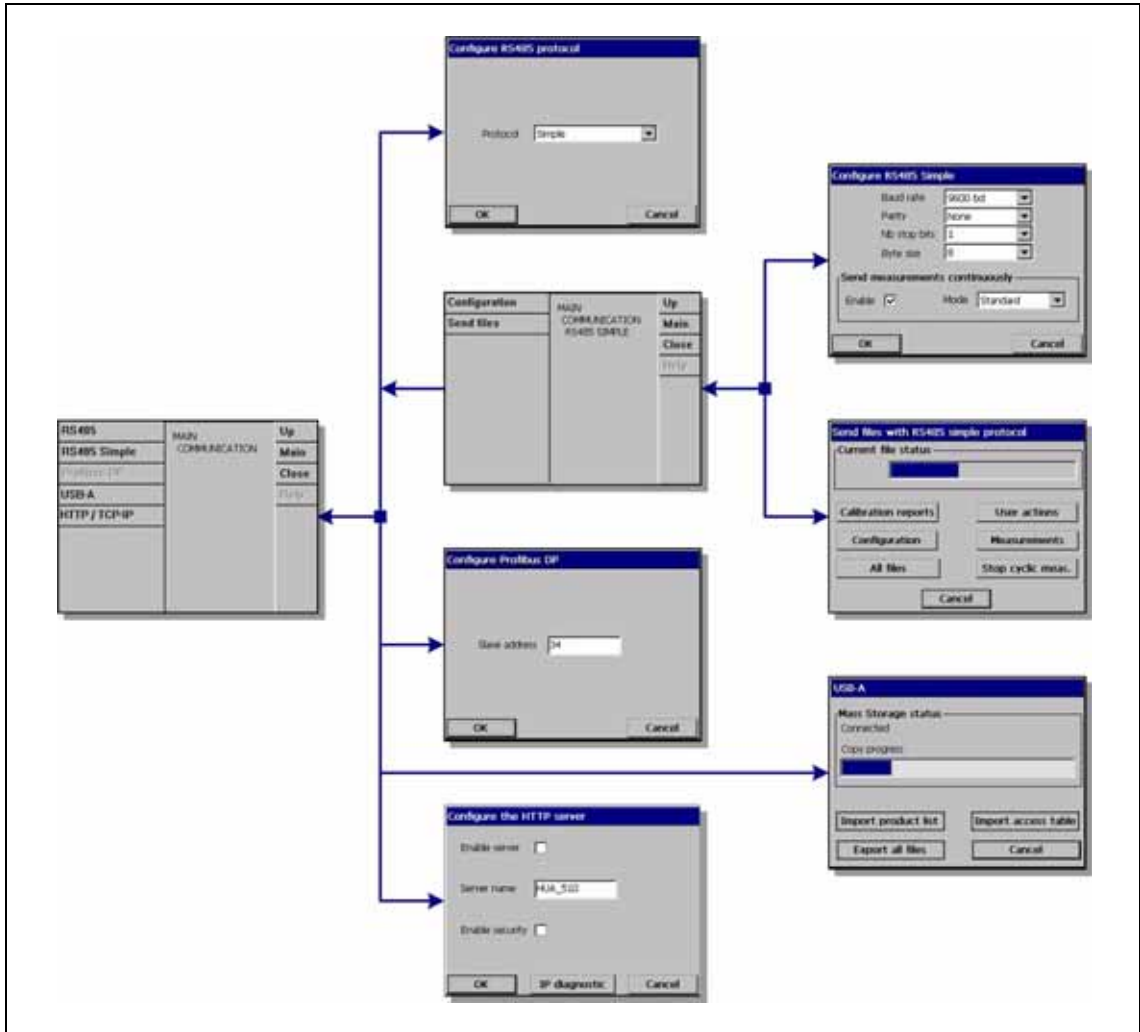
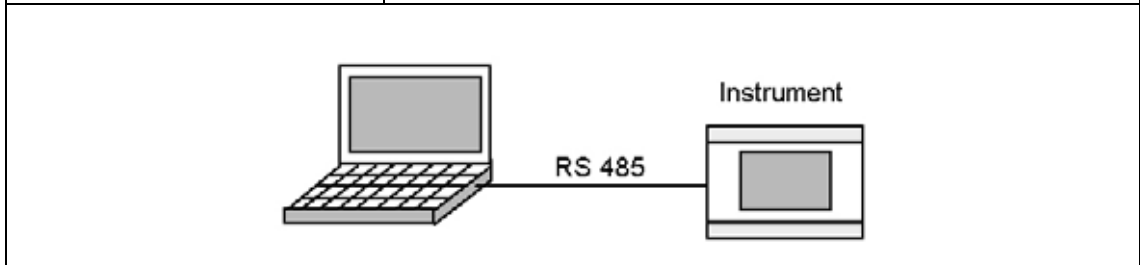

Figure 42 Communication menu

	<p>The external RS-485 port of the main board is directly connected to a RS-485 bus (single twisted pair). Optionally it can be connected to a fieldbus module (gateway).</p> <p>The RS 485 menu allows to select between RS485 simple or Profibus DP communication protocol, depending on application.</p> <ul style="list-style-type: none"> <li>• Press on the text box to select either the RS-485 simple or the PROFIBUS-DP communication protocol.</li> </ul>
--	---



## 9.1 RS-485 simple mode configuration

This protocol allows the instrument to output data to an external device (PLC, SCADA, PC, etc.). The communication is unidirectional. The data are output on the RS-485 link as simple ASCII text. If for instance you use a PC, the data can be easily visualized and saved in a file using the "Hyperterminal" software.

To use this communications mode, on the instrument:

- Select the **RS-485** option from the **Communication** menu
- Choose the protocol **Simple** (default configuration) and press on **OK**
- Then select the **RS-485 Simple** option from the **Communication** menu to display the following screen:

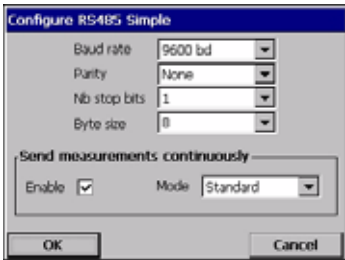
	<ul style="list-style-type: none"><li>• "Baud rate", "Parity", "No of stop bits", "Byte size" Standard parameters of the RS-485 link.</li><li>• "Enable" The measurements can be sent continuously (approximately every 2 sec.). This field allows enabling or disabling this feature.</li><li>• "Mode" This is the format of the measurements sent continuously (see <a href="#">Cyclic measurements on page 75</a> of this document). In "Expert" mode, more data are sent. These additional data can be useful for diagnostic purpose.</li></ul>
<p><b>Note:</b> In case of problem verify first that jumper J3 is not installed on the mother board (default configuration).</p>	

### Send data

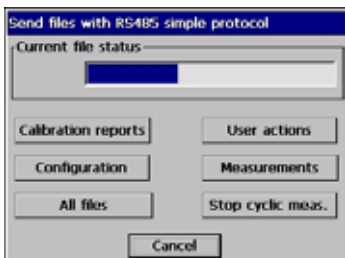
	<p>This dialog box is used to send text files to an external device. The possible files are the following:</p> <ul style="list-style-type: none"><li>• Calibration reports</li><li>• User actions log file</li><li>• Instrument configuration</li><li>• Measurements stored in the instrument memory.</li></ul>
---	---

The button "Stop Cyclic meas." allows to stop and to restart the cyclic transmission of measurements. It is advised to stop the cyclic transmission in order not to mix cyclic measurements and data of the file being transmitted. This button has the same effect as the "Enable" checkbox of the "Communication/RS-485 Simple/Configuration" window.

After stopping the cyclic measurements, select the "Calibration Reports", "User Actions", "Configuration", "Measurements" button to send the corresponding file, or the "All files" button to send all these files in one shot.

Once the button is pressed, the file is sent immediately. The field "Current file status" shows "Sending" alongside the file transmission progress bar. On completion this changes to "Sent".

9.1.1 Data available

All individual data are separated by at least one tabulation character (ASCII code=0x09).

For the cyclic measurements, the data format is detailed. For the files, only one example for each file is given to explain the data format.

Cyclic measurements

1. If the option "Mode = standard" is chosen, the following message is sent:

CHn\t	Gas\t	Gas Unit\t	Temperature\t	Temperature Unit\t	Barometric Pressure\t	Barometric Pressure Unit\t	Event\t\r\n
-------	-------	------------	---------------	--------------------	-----------------------	----------------------------	-------------

with:

- \t .....the ASCII tab character: code=0x09
- \r .....the ASCII Carriage Return character: code=0x0D
- \n .....the ASCII Line Feed character: code=0x0A
- CHn .....the 2 ASCII characters "CH" + the channel no.
- Gas .....the gas concentration.
- Gas Unit .....the gas unit.
- Temperature .....the temperature.
- Temperature Unit.....the temperature unit.
- Barometric Pressure.....the barometric pressure.
- Barometric Pressure Unit .....the barometric pressure unit.
- Event .....the event bit mask in hexadecimal format.

The values are not described here (see [List of events and alarms on page 104](#)).

- Example of one measurement:

CH1 697.176 mbar 20.1 °C 0.982 bar C00

2. If the option "Mode = expert" is chosen, the following message is sent:

CHn\t	Gas\t	Gas Unit\t	Temperature\t	Temperature Unit\t	BarometricPressure\t	Barometric Pressure Unit\t			
		Event\t	Phase Shift\t	°\t	Partial Pressure\t	bar\t	Reference Phase\t	°\t	
		Fluorescent Phase\t	°\t	Reference Amp\t	V\t	Fluorescent Amp\t	V\t	Time\t	Index\r\n

with:

- Phase shift.....The fluorescence phase shift in [°].
- Partial pressure .....The partial pressure in [bar].
- Time .....The time of the measurement. Format "hh:mm:ss."
- Index.....This is the index of the last measurement.

This number starts at 0 at power up of the program. The following is an example of one measurement:

CH1 697.173 ppb 20.1 °C 0.982 bar C00 26.045 ° 0.69700 bar  
 -21.409 ° -64.991 ° 2.349 V 2.493 V 12:59:42 5923

**Gas sensor calibration report example**

Calibration report nb 1  
 Mode . . . . . Manual high level calibration  
 Date (yy.mm.dd - hh:mm) . . . . . 05.02.17 - 18:40  
 Operator . . . . . jp  
 Operator ID . . . . . 3  
 Calibration sample . . . . . In line sample  
 Medium . . . . . Liquid  
 Gas unit . . . . . ppb  
 Liquid . . . . . Water  
 Reference value . . . . . 1.500000  
 Calibration coefficient Phi0 . . . . . 25.974°C  
 Calibration coefficient Tcal. . . . . 24.41°  
 Calibration coefficient Ksv . . . . . -0.1312 mbar-1  
 Standard deviation . . . . . 0.003 mbar  
 Fluorescent amplitude . . . . . 0.834 V  
 Temperature . . . . . 20.1 °C  
 Calibration duration . . . . . 3 mn

**Barometric sensor calibration report example**

Calibration report nb 1  
 Date (yy.mm.dd - hh:mm) . . . . . 05.02.16 - 20:38  
 Operator . . . . . jp  
 Operator ID . . . . . 3  
 Previous barometric pressure . . 0.956 bar  
 New Barometric pressure . . . . . 0.976 bar  
 Calibration offset . . . . . 3.73 [kPa]

**User action log file example**

The "User action log file" below contains 3 user actions.

<i>Nr</i>	<i>mm/dd</i>	<i>hh:mm:ss</i>	<i>User ID</i>	<i>User Name</i>	<i>Action ID</i>	<i>Description</i>
1	1/21	15:13:44	1007	Armstrong	139	Change Time/Date
0	1/21	15:13:27	1007	Armstrong	501	Calib. parameters
2	1/21	15:12:15	1007	Armstrong	132	Identification

**Measurement file example**

6 measurements are described below:

<i>Nr</i>	<i>mm/dd</i>	<i>hh:mm:ss</i>	<i>Gas</i> <i>[ppb]</i>	<i>Temp</i> <i>[°C]</i>	<i>Mask</i>	<i>Fluor. phi</i> <i>[°]</i>	<i>Barom</i> <i>[bar]</i>	<i>Ext P.</i> <i>[bar]</i>	<i>Index</i>
0	2/17	21:15:37	75.051	20.1	400	26.039	1.005	1.977	2271
1	2/17	21:15:27	75.043	20.1	400	26.045	1.005	1.976	2266
2	2/17	21:15:17	75.047	20.1	400	26.052	1.005	1.976	2261
3	2/17	21:14:57	75.044	20.1	400	26.041	1.005	1.976	2256
4	2/17	21:14:47	75.047	20.1	400	26.038	1.005	1.977	2251
5	2/17	21:14:37	75.050	20.1	400	26.054	1.005	1.976	2246

```

Configuration report example
INSTRUMENT CONFIGURATION
Measurement mode . . . . . Continuous mode
Pressure unit. . . . . bar
Temperature unit. . . . . °C
Storage mode . . . . . Rolling buffer
Storage RAM time. . . . . 10 [s]
Storage FLASH time. . . . . 3600 [s]

Membrane . . . . . Power OT
Medium . . . . . Liquid
Gas unit. . . . . ppm->ppb
Liquid . . . . . Water
Resolution displayed. . . . . 1
Thermal cut off . . . . . Disabled 65.0 [°C]
Alarm Low Low . . . . . Enabled 100.000000 [ppb]
Alarm Low . . . . . Enabled 200.000000 [ppb]
Alarm High . . . . . Enabled 9000.000000 [ppb]
Alarm High High . . . . . Enabled 10000.000000 [ppb]
Alarm Hysteresis. . . . . 5 [%]
Alarm Delay . . . . . 15 [s]
Filter State . . . . . Enabled
Filter Type . . . . . Median
Filter Depth . . . . . 5
Filter Central depth . . . . . 1
    
```

**9.1.2 Example of use**

In this example we use:

- One PC with a RS232 port.
- One "RS-485<->RS232 converter"

Procedure:

1. Connect both RS-485 wires of the instrument to the "RS-485<->RS232 converter".
2. Connect the "RS-485<->RS232 converter" to the PC RS232 port using a standard cable (RS232 DB9 straight cable).

On the PC:

1. Run "Hyperterminal" on the PC.
2. Configure the PC COM port used (e.g. COM2). Menu "File/Properties/Configure".
3. Configure the parameters "Baud rate", "Parity", "Nb of stop bits", "Byte size" (Menu "File/Properties/Configure"). Use the same parameters for the instrument and the PC.
4. Configure the "Font = Courier 10" (Menu "View/Font").
5. Connect "Hyperterminal" (Menu "Call/Call").
6. Save the data received in the file of your choice (Menu "Transfer/Capture Text/Start").

On the instrument:

1. Use the menu "Communication/RS-485 Simple/Send files" and the button "All files". When the transfer is finished, close the file with "Hyperterminal" (Menu "Transfer/Capture Text/Stop"). Now, all the reports are saved in a text file on your PC.

## 9.2 PROFIBUS-DP communication (optional)

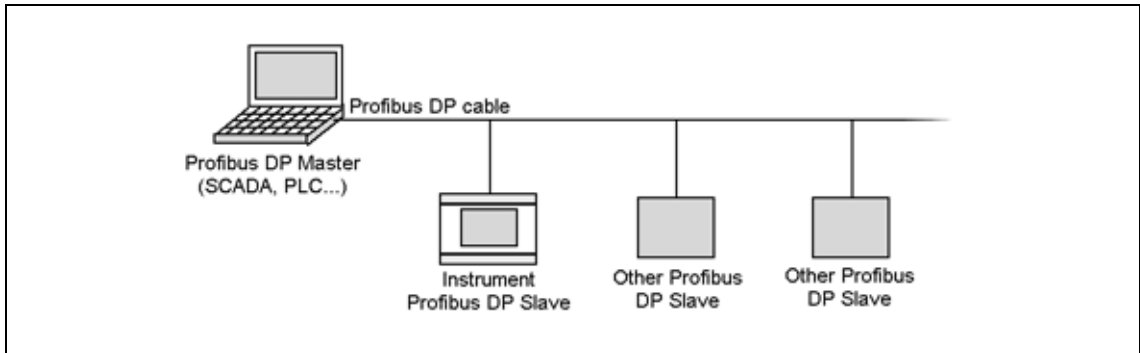

### 9.2.1 Installation

On the ORBISPHERE CD, there is an “Orbi2079.gsd” and an “Orbi2079.bmp” file available in the “Profibus DP” folder to help configure the PROFIBUS-DP. The GSD file contains the following elements:

- A module to decode the barometric pressure value and unit
- A module to convert the channel measurement data such as gas concentration, gas unit, temperature, temperature unit and the events.



#### **WARNING**

*Installation should be performed exclusively by personnel specialized and authorized to work on electrical installations, in accordance with relevant local regulations. Disconnect the power supply of the instrument before carrying out any work inside the instrument.*

#### **CAUTION**

*Proper ESD (electrostatic discharge) protocols must be followed to prevent damage to the product. All fittings must be properly seated and tightened to prevent any water and dust ingress.*

1. Install the PROFIBUS-DP module and the jumper J3 on the main board (location highlighted in the illustration below).

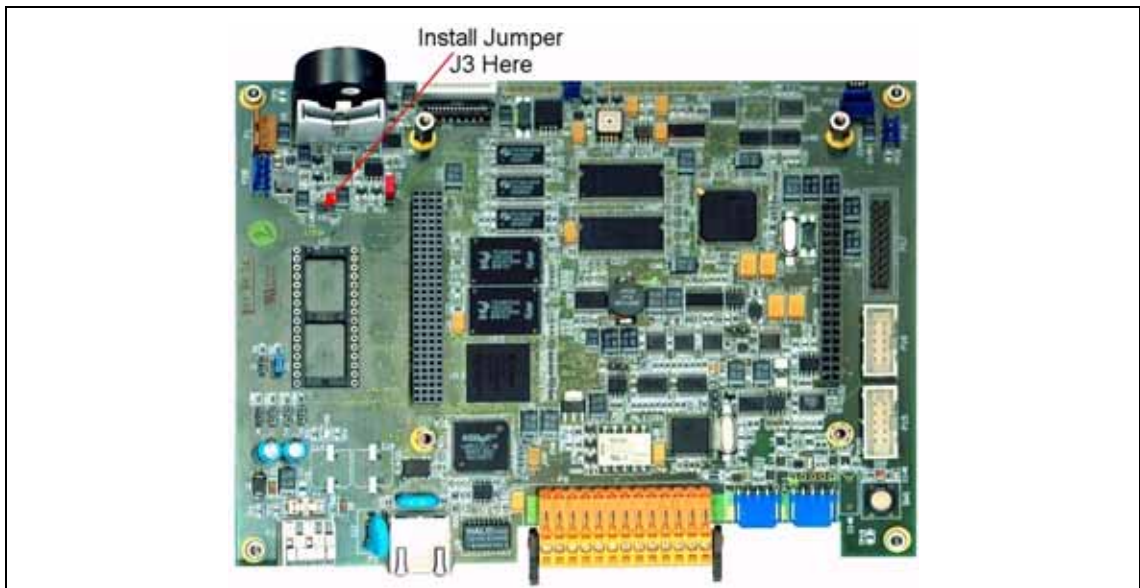

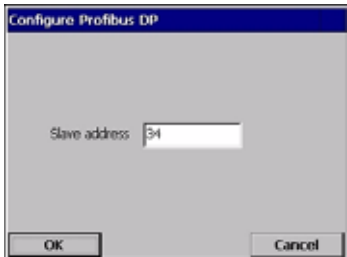

	<ol style="list-style-type: none"> <li>2. Select the menu "Configuration/RS-485" and choose "PROFIBUS-DP" as the protocol.</li> <li>3. Select the menu "Configuration/PROFIBUS-DP", choose the slave address and restart the instrument.</li> </ol>
---	---

### 9.2.2 Input/Output data

The main board:

- Writes the latest measurement data to the Profibus Input Buffer.
- Checks if a command written by the Profibus Master must be executed (Profibus Output Buffer). If a command is to be executed, the instrument executes it and writes the result (status, data, etc.) in the Profibus Input Buffer.

All numbers are coded in "Big Endian" format, and float values are coded according to IEEE Standards. The field types "Byte" and "Double Word" are unsigned.

#### Measurements

Measurements are formatted in the Profibus Input Buffer as follows:

Name	Type	Size	Offset
Barometric pressure	Input float	32 bits	0
Barometric pressure unit	Input byte	8 bits	4
Channel 1 gas concentration	Input float	32 bits	5
Channel 1 gas unit	Input byte	8 bits	9
Channel 1 temperature	Input float	32 bits	10
Channel 1 temperature unit	Input byte	8 bits	14
Channel 1 external pressure	Input float	32 bits	15
Channel 1 external pressure unit	Input byte	8 bits	19
Channel 1 events	Input double word	32 bits	20
Channel 1 measurement index	Input double word	32 bits	24

The gas, temperature and barometric pressure unit values are coded as defined in the following tables:

Gas unit	Value
bar	0
mbar	1
Pa	2
kPa	3
hPa	4
psia	5
atm.	6
mbar->bar	9
Pa->KPa	10
%Vbar	12
ppm Vbar	13
%Vext	14
ppm Vext	15
ppm Vbar->%Vbar	16
ppm Vext->%Vext	17
ppm	18
ppb	19
g/l	20
mg/l	21
µg/l	22
%O <sub>2</sub>	23
%Air	24
g/kg	25
V/V	26
%W	27
cc/kg	28
ml/l	29

Temperature unit	Value
K	0
°C	1
°F	2

Barometric pressure unit	Value
bar	0
mbar	1
psia	2
atm.	3
Pa	4
kPa	5
hPa	6

**Note:** For the field "Event", please see the column "Bit mask value" in [Table 3 on page 104](#).

**Note:** If the instrument stops sending measurement data to the module, then after 30 seconds the module sets the event mask to the value **PROFIBUS-DP value not updated** (0x80000000) bit mask.

**Commands**

The “Command Output Buffer” is formatted as follows:

Name	Type	Size	Offset
Output command toggle (OCT)	Output byte	8 bits	0
Output command ID (OCI)	Output byte	8 bits	1
Output command data byte 1 (OCD1)	Output byte	8 bits	2
Output command data byte 2 (OCD2)	Output byte	8 bits	3
Output command data byte 3 (OCD3)	Output byte	8 bits	4
Output command data byte 4 (OCD4)	Output byte	8 bits	5

The “Command Input Buffer” is located just after the measurement data and is formatted as follows:

Name	Type	Size	Offset
Input command toggle (ICT)	Input byte	8 bits	74
Input command status (ICS)	Input byte	8 bits	75
Input command data byte 1 (ICD1)	Input byte	8 bits	76
Input command data byte 2 (ICD2)	Input byte	8 bits	77
Input command data byte 3 (ICD3)	Input byte	8 bits	78
Input command data byte 4 (ICD4)	Input byte	8 bits	79

The following commands are available:

- Change product

**Change product command - output**

Name	Value	Comment
OCT	1-2	
OCI	1	
OCD1	0	Channel number: 0 = Channel 1
OCD2	0-99	Product number
OCD3	0-1	Erase measurement files: 0 = Never erase the measurement files. 1 = Erase measurement file if necessary (e.g. gas unit changes)
OCD4		Not used

**Change product command - input**

Name	Value	Comment
ICT	1-2	
ICS	0-3	0 = OK 1 = Unknown command ID 2 = Invalid parameter (e.g. invalid channel no or product number) 3 = Execution failure
ICD1		Not used
ICD2		Not used
ICD3		Not used
ICD4		Not used

## 9.3 USB-A port (host)

This option allows the export or import of data from an external mass storage device. The device must first be connected to the instrument through the USB-A port.

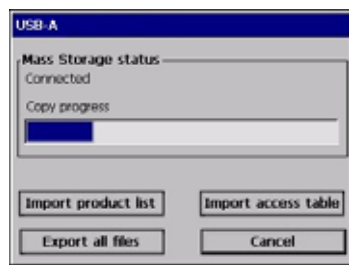
	<p>Select one of the two import options (product list or access table) to import data from the storage device. This is useful for transferring these files to additional instruments without the need of having to re-enter the data individually on each instrument.</p> <p><b>Note:</b> The imported data will override any current settings on the instrument.</p>
---	---

Select the export option to export data from the instrument to the storage device. For information regarding the uploaded files, refer to [Uploaded Files on page 88](#).

For both import and export options, the progress bar is updated to give an indication of the progress of the selected option.

## 9.4 HTTP/TCP-IP

### 9.4.1 Overview

When activated this option downloads data from the instrument directly to a web page that can be accessed from a PC. To be able to use this option, the instrument must be connected to the network (specifically **Connector P3** - see details in [Main board connections on page 33](#)) and the network must have a DHCP server installed.

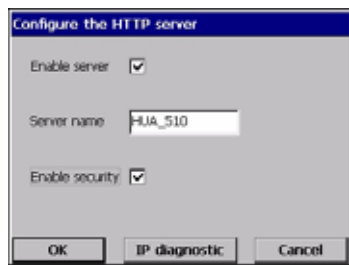
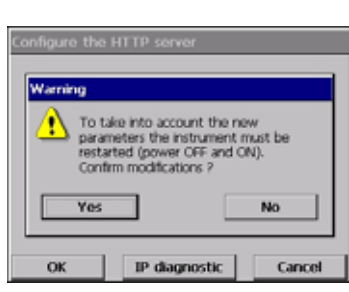
	<ul style="list-style-type: none"><li>• Check the Enable server box to enable the web server communication link.</li><li>• Enter the Server name for the instrument. This is free format text and should typically be used to identify the instrument.</li><li>• Check the Enable security box if you require a password to be entered on the PC to access the web page.</li></ul>
	<p>If any of the details on the previous screen have been changed, a warning message will be displayed as illustrated left.</p> <p>The changes must be confirmed, after which the instrument must be powered down and powered up again for the changes to take effect.</p> <p><b>Note:</b> The IP Diagnostics button at the bottom of the screen is for use by experienced IT personnel only to help resolve any communications problems.</p>

### 9.4.2 PC interface

Once the server has been enabled and the interface information set up, access the information by launching an internet browser and typing “**http://**” followed by the server name that has been assigned to the instrument, in the address box as illustrated below:

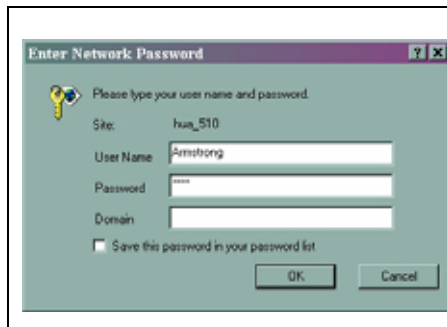

If the enable security option has been checked on the instrument, you will be required to enter a username and password on your PC to gain access to the web page.

The username and password must be a valid username/password combination that has been set up on the instrument (see also [User management on page 90](#) on how to set up users on the instrument).

Domain information is not required.

Once a valid username/password combination has been entered, the initial web page will be displayed giving a list of options:

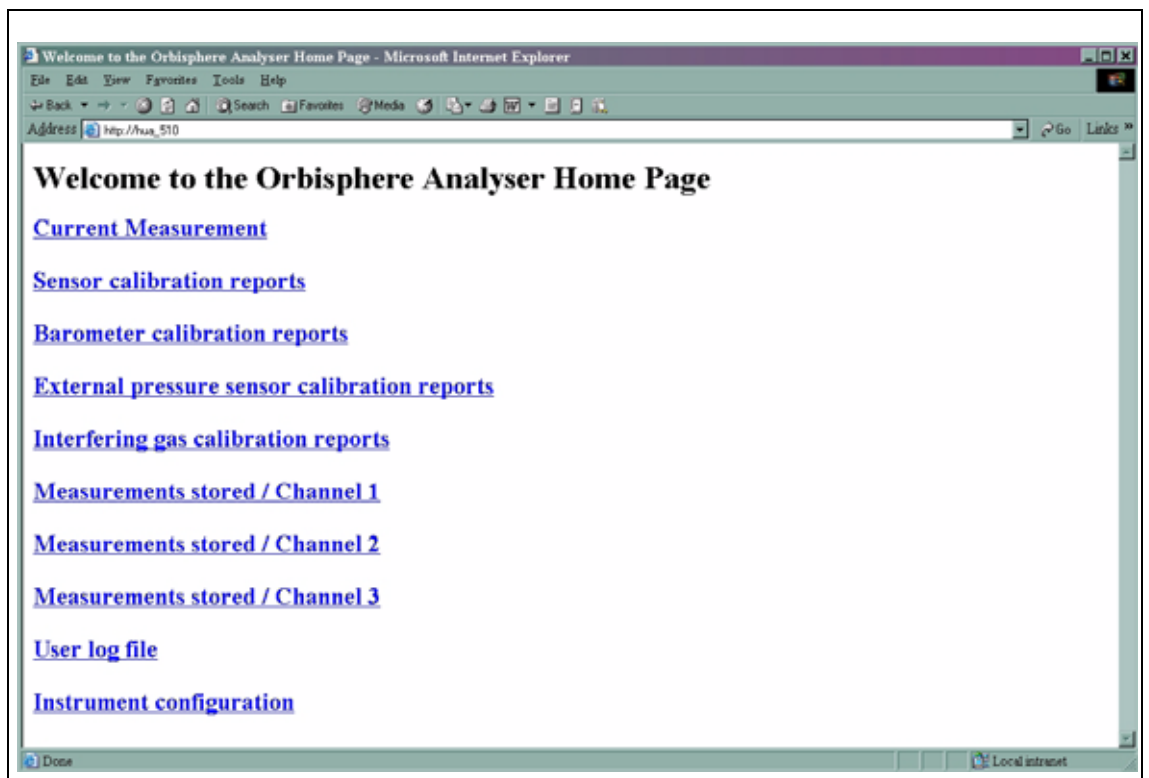

Click on any of these options and the data will be displayed on the PC screen. The following shows an example of the screen when selecting the Current Measurement option:

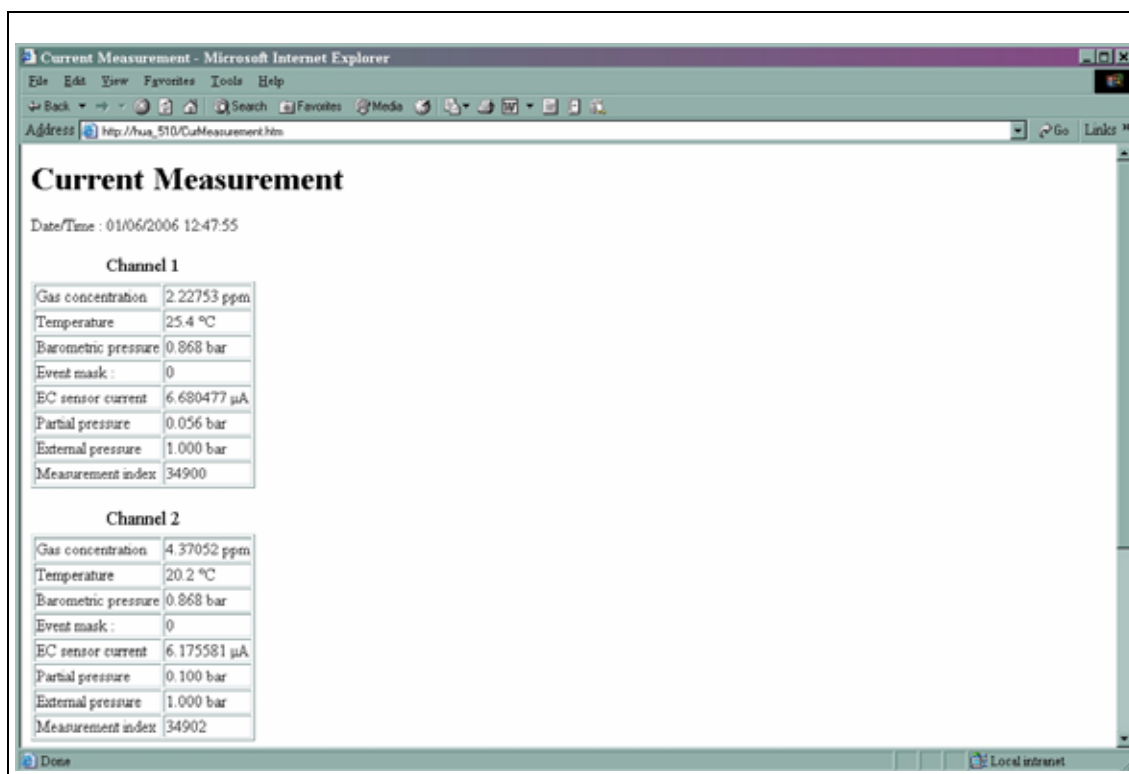

## 9.5 Data file transfer through the USB-B port (client)

The USB port allows you to copy data files from the instrument to a PC using the Microsoft ActiveSync® software. The files in the instrument are coded in a binary format, so they must be converted to a readable format on your PC to make them suitable for viewing. This is done automatically using the software supplied on the ORBISPHERE CD (see [PC software installation](#) below and [Upload report files on page 87](#) for details).

Check that the instrument and PC are powered, then connect them with the USB cable that was supplied with the instrument. Follow the instructions below:

### 9.5.1 PC software installation

Insert the ORBISPHERE CD inside the PC drive. If the auto executable installation does not start, browse the CD with Windows Explorer and double click on the "setup.exe" file to start the installation. Follow the step by step instructions appearing on the screen.

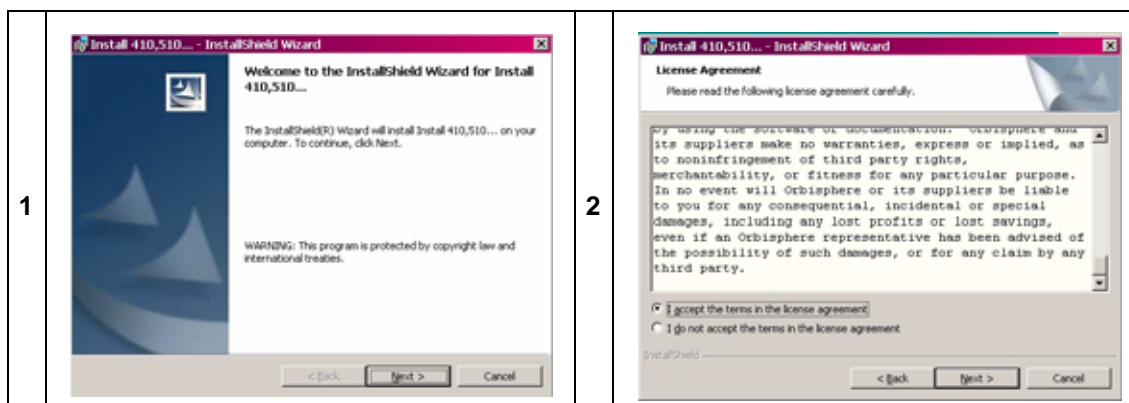

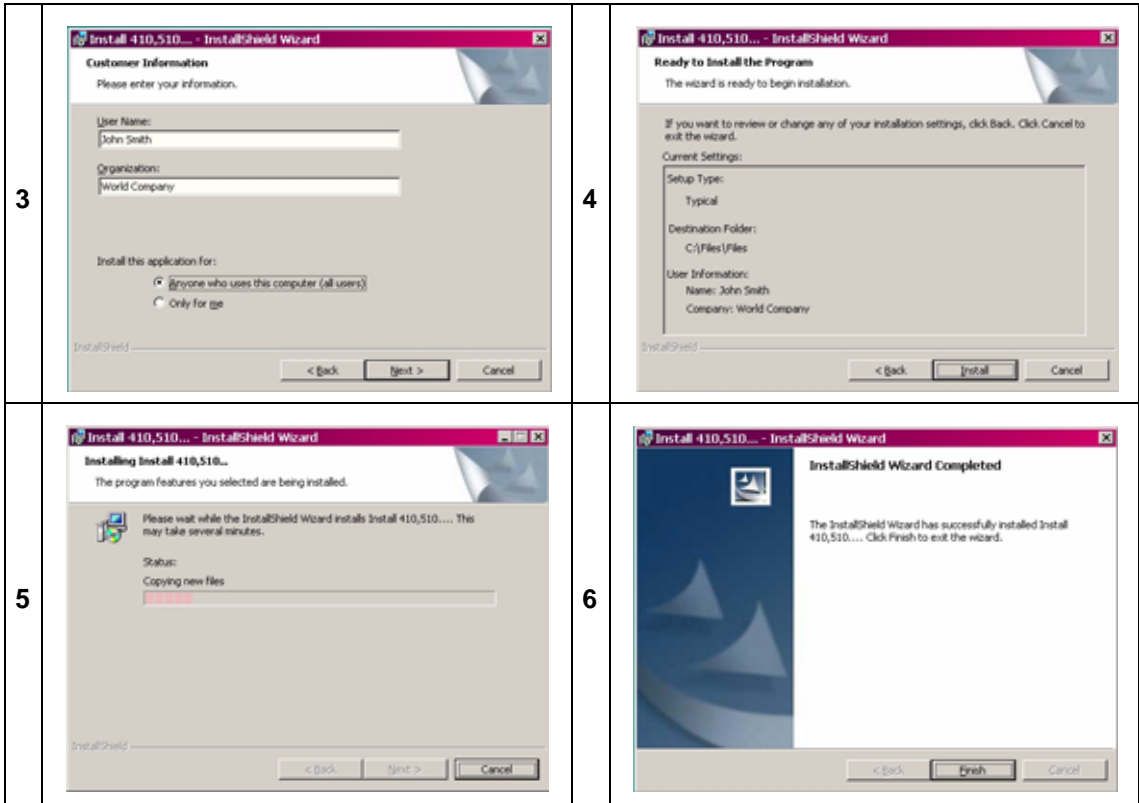

Once the installation is complete, two icons are installed on the PC Desktop:

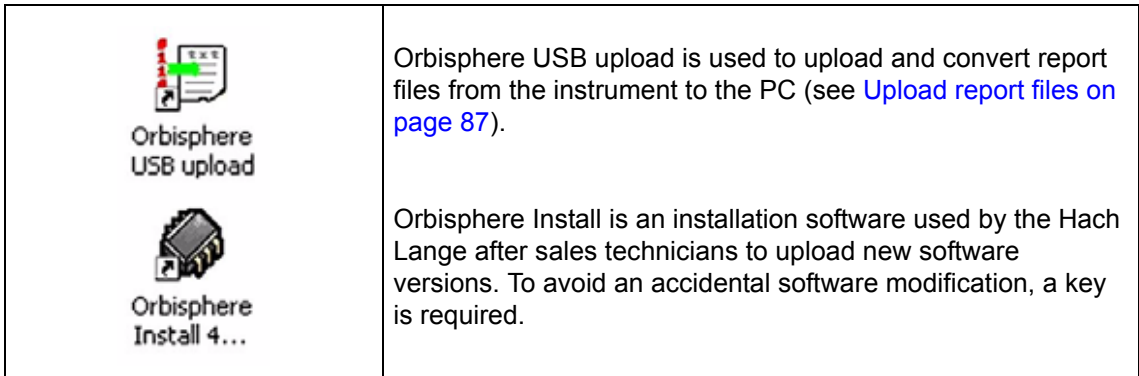

### 9.5.2 Microsoft ActiveSync® configuration

The latest version of ActiveSync® can be downloaded and installed from:

[www.microsoft.com/windowsmobile/downloads](http://www.microsoft.com/windowsmobile/downloads)

**Note:** A copy of the ActiveSync® software is also available on the ORBISPHERE CD. Inside the ActiveSync folder, double click the “MSASYNC.EXE” executable file to install on the PC.

	<p>Once successfully installed, ActiveSync® will start automatically each time the instrument is connected to the PC.</p> <p><b>Note:</b> By default ActiveSync® proposes to set up a partnership with the instrument. This is not required, so make sure this is set to <b>NO</b> (as illustrated left) before continuing.</p>
	<p>The ActiveSync® screen is then displayed and an icon will appear in the taskbar at the bottom of your screen.</p>

	<p>When active the icon in the taskbar is colored green (as illustrated top left) and when inactive, the icon is still visible but greyed out (as illustrated bottom left).</p>
--	---



### 9.5.3 Upload report files



Double click on the **Orbisphere USB upload** icon on the PC desktop (created during the process described previously in [PC software installation on page 84](#)) to start the upload and convert process.

When the main screen is displayed, click on the Wizard button  in the top left corner.

#### Step 1

 <p>The screenshot shows a dialog box titled "Step 1" with the following text: "Please: - Connect the USB cable and check that the ActiveSync program detects properly the connection. - Press the button 'Next &gt;&gt;'". There are "Next &gt;&gt;" and "Cancel" buttons at the bottom.</p>	<p>Check that the USB connection from the instrument to PC has been made, and that the ActiveSync® software has been activated and the link recognized (the icon in the taskbar should be colored green). Click on <b>Next</b>.</p>
--	---

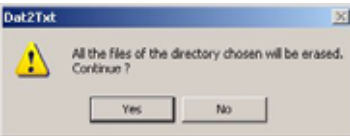
#### Step 2

 <p>The screenshot shows a dialog box titled "Step 2" with the following text: "Please: - Choose the PC folder where to store the files uploaded." Below this is a text field containing "C:\Orbisphere\Data\HUA_510 18-Jan-06 0950\" and a "Browse" button. Below the text field is the instruction "- Press the button 'Next &gt;&gt;'". There are "Next &gt;&gt;" and "Cancel" buttons at the bottom.</p>	<p>Choose the directory where the files are to be stored. If the directory path does not exist it will be automatically created. Click on <b>Next</b>.</p>
 <p>The screenshot shows a warning dialog box titled "Dat2Txt" with a yellow warning icon and the text: "All the files of the directory chosen will be erased. Continue?". There are "Yes" and "No" buttons at the bottom.</p>	<p>A warning message appears to warn that all files currently in the directory (if any exist) will be deleted prior to upload. Click on <b>Yes</b> to continue with the process or <b>No</b> to abort. If Yes is selected, a progress bar of the upload is displayed.</p>
 <p>The screenshot shows a warning dialog box titled "Warning" with a yellow warning icon and the text: "File CalibrationTable0.dat not found". There is an "OK" button at the bottom.</p>	<p>Should any of the files be missing (e.g. a calibration file will be missing if no calibration has been performed), a warning message is displayed, but no action is required. Click on <b>OK</b>.</p>

#### Step 3

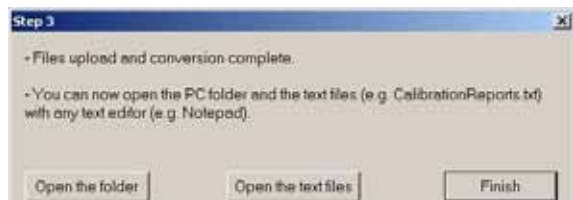
 <p>The screenshot shows a dialog box titled "Step 3" with the following text: "- Files upload and conversion complete. - You can now open the PC folder and the text files (e.g. CalibrationReports.txt) with any text editor (e.g. Notepad)". There are "Open the folder", "Open the text files", and "Finish" buttons at the bottom.</p>	<p>Once the upload is complete, the files are converted and stored in the folder defined in Step 2 above. Click on <b>Finish</b> to terminate the process, or on either of the other two buttons to open the folder or view the text files.</p>
--	---

### Uploaded Files

There are a number of files that are uploaded to the PC during this process. However, only the text files (with a **.txt** file extension) are in a readable format on the PC. Most document editors (Word, Notepad, etc.) can be used to open these files, as well as spreadsheet and other reporting tools (e.g. Excel).

There are four reports available:

- Instrument Configuration
- Calibration Reports
- Measurements
- User Actions

Below is an example of the Instrument Configuration report as viewed using the Notepad utility.

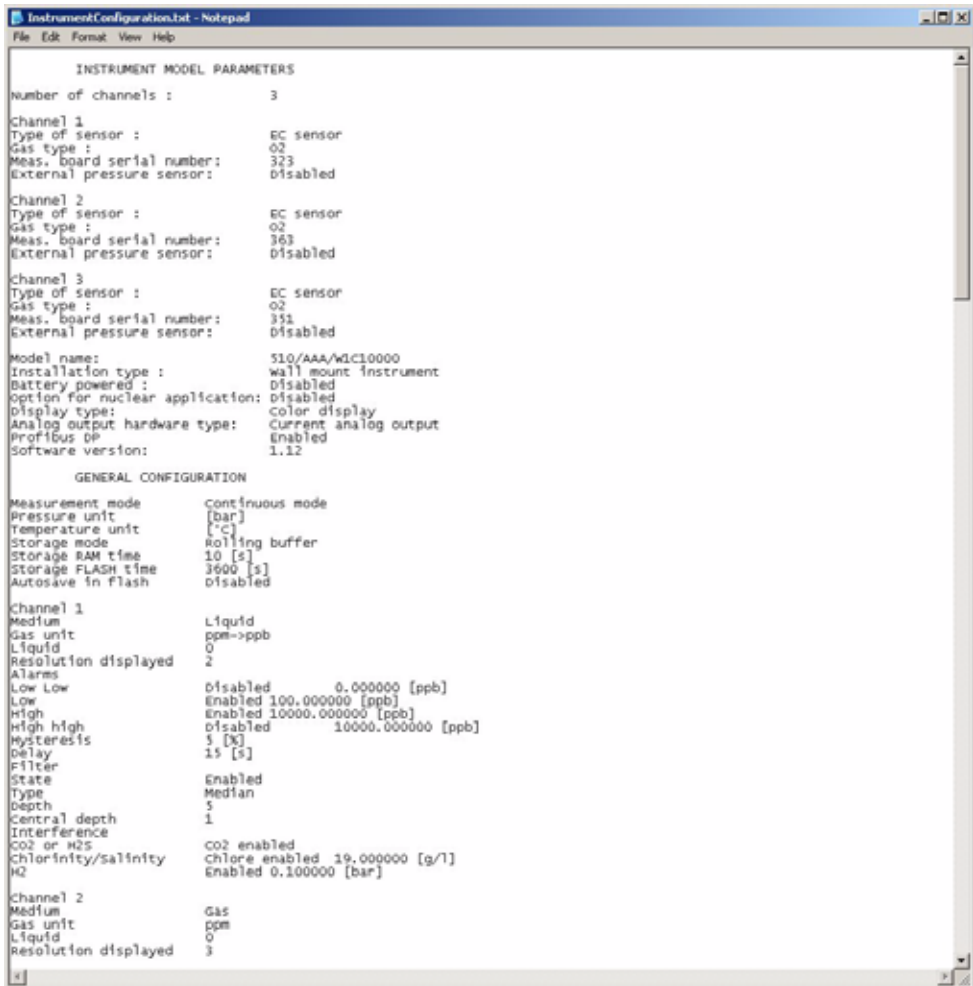

```
InstrumentConfiguration.txt - Notepad
File Edit Format View Help

INSTRUMENT MODEL PARAMETERS
Number of channels :          3
Channel 1
Type of sensor :             EC sensor
Gas type :                   O2
Meas. board serial number:   323
External pressure sensor:    disabled
Channel 2
Type of sensor :             EC sensor
Gas type :                   O2
Meas. board serial number:   363
External pressure sensor:    disabled
Channel 3
Type of sensor :             EC sensor
Gas type :                   O2
Meas. board serial number:   351
External pressure sensor:    disabled
Model name:                  SI0/AAA/WdC10000
Installation type :          wall mount instrument
Battery powered :            disabled
option for nuclear application: disabled
Display type:                color display
Analog output hardware type: current analog output
Profibus DP                  enabled
Software version:            1.12

GENERAL CONFIGURATION
Measurement mode              Continuous mode
Pressure unit                 [bar]
Temperature unit             [°C]
Storage mode                  Rolling buffer
Storage RAM time             10 [s]
Storage FLASH time           3600 [s]
Autosave in flash           disabled

Channel 1
Medium                       Liquid
Gas unit                     ppm->ppb
Liquid                       0
Resolution displayed         2
Alarms
Low Low                      disabled 0.000000 [ppb]
Low                          enabled 100.000000 [ppb]
High                         enabled 10000.000000 [ppb]
High high                    disabled 10000.000000 [ppb]
Hysteresis                   5 [%]
Delay                        15 [s]
Filter
State                        enabled
Type                         Median
Depth                       5
Central depth                1
Interference
CO2 or H2S                   CO2 enabled
Chlorinity/salinity          chore enabled 19.000000 [g/l]
H2                           enabled 0.100000 [bar]

Channel 2
Medium                       Gas
Gas unit                     ppm
Liquid                       0
Resolution displayed         3
```

# Section 10 Security Menu

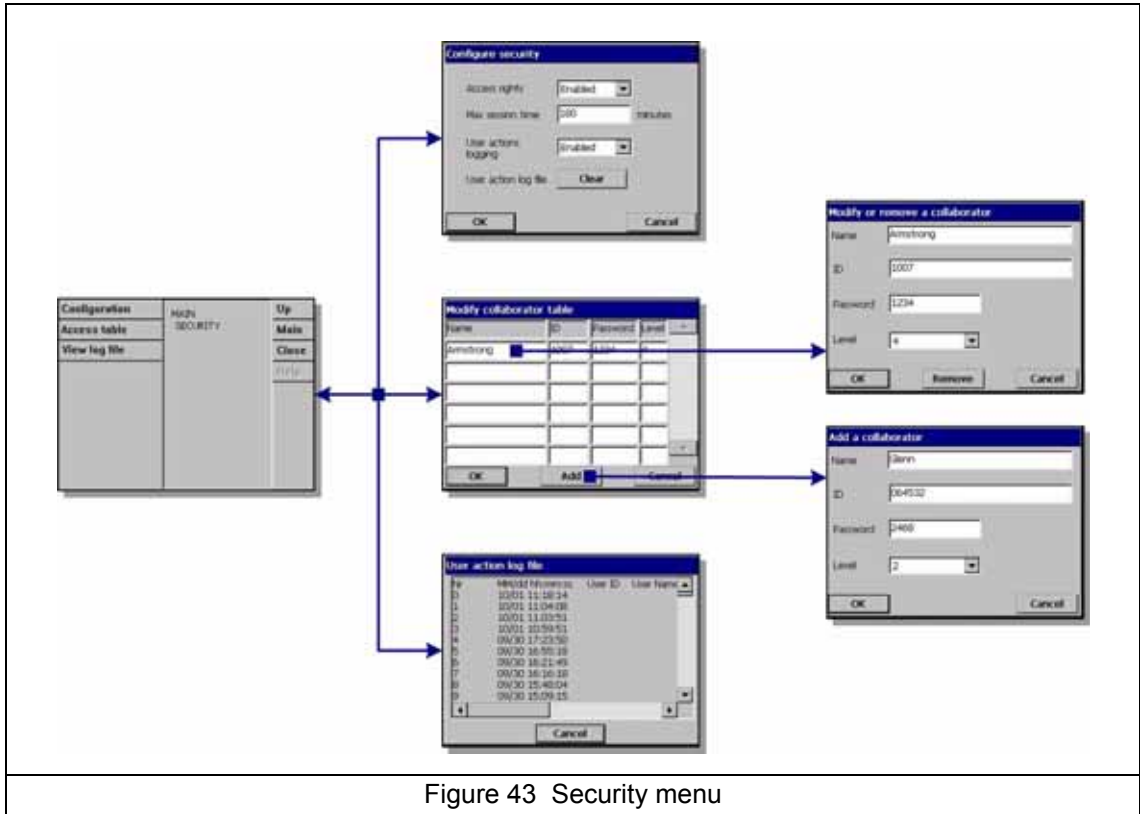

Figure 43 Security menu

**Note:** When the instrument is started for the very first time, security is disabled by default. It is highly recommended that each user be entered into the system and given appropriate access rights as soon as possible to avoid any unauthorized access. Details of this process are described in this section.

## 10.1 Access rights management

Each user has a unique ID and user password. The ID and password are used by the software to:

- Allow or deny a user to perform specific actions.
- To trace this action with his "ID" in a log file.

Once the ID and password are entered, the user is allowed to perform actions according to the "Access level" that has been attributed to his ID by the Manager. See [Security level table on page 18](#).

Level	Typical rights	Comments
0	View parameters, change views	Press the unlock button and OK to access
1	+ Start / Stop measurements	
2	+ Calibration	
3	+ Modify parameters	
4	+ Modify table "User ↔ Access level" + Enable/Disable "Access right" features	There is at least one ID having the level 4

At startup, all the menus are locked. The user has to identify himself to get access beyond the different views (see [Function keys on the header bar on page 40](#))

## 10.2 Configure security

This enables defining the users with their access level when the software starts for the first time. It is possible to configure several parameters related to confidentiality. This requires a user access level 4.

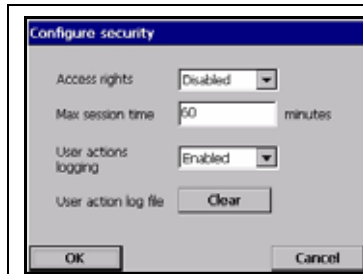

**Note:** Access rights are disabled by default.

- Access rights: When enabled, it is required to log in as a registered user (see [User management on page 90](#)) to access the menus. When disabled (default), all menu are access free, and the effect of leaving the text box blank in user login window is that there will be no name recorded for the action in the log file.
- Enter a maximum session time in minutes for improved confidentiality. The user is logged out automatically when the set delay for inactivity is over.
- User action logging: When enabled, every action from a logged on user is recorded in a user log file for traceability.
- Clear all user actions log file. Confirm to clear the log file. This functionality is aimed at clearing demo or test logs for example. The log file is a rolling buffer recording the past 100 actions.

## 10.3 User management

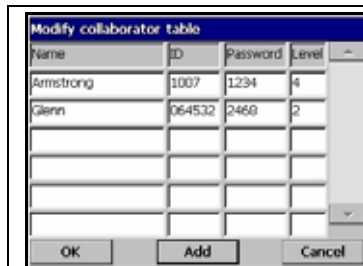

This window shows the list of registered users for the instrument. They are listed by name, ID, password and access level.

**Note:** The "User password" must be at least 4 characters long.

Pressing on an empty line, or pressing the Add button brings a window to add a new user. Name, ID, password and access level (from 1 to 4) must be entered.

Pressing on a registered user line brings a window for editing or deleting the user data in the list.

**Note:** The list can contain up to 99 users

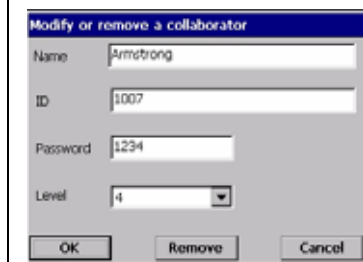

## 10.4 User action log file

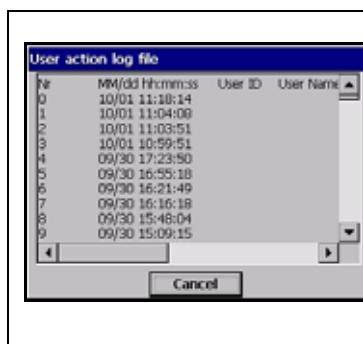

Each time the user performs an important action, a record is written in the "User action log file". It is a rolling buffer which contains the last 1000 user actions. The "User Interface" will allow viewing this log file (Menu Security / View log file). This log file contains the following data:

- line number
- the action name
- the user name and ID
- the current date and time.

**Note:** Unsuccessful attempts to register are recorded in the log file without a user ID.

## Section 11 Products Menu

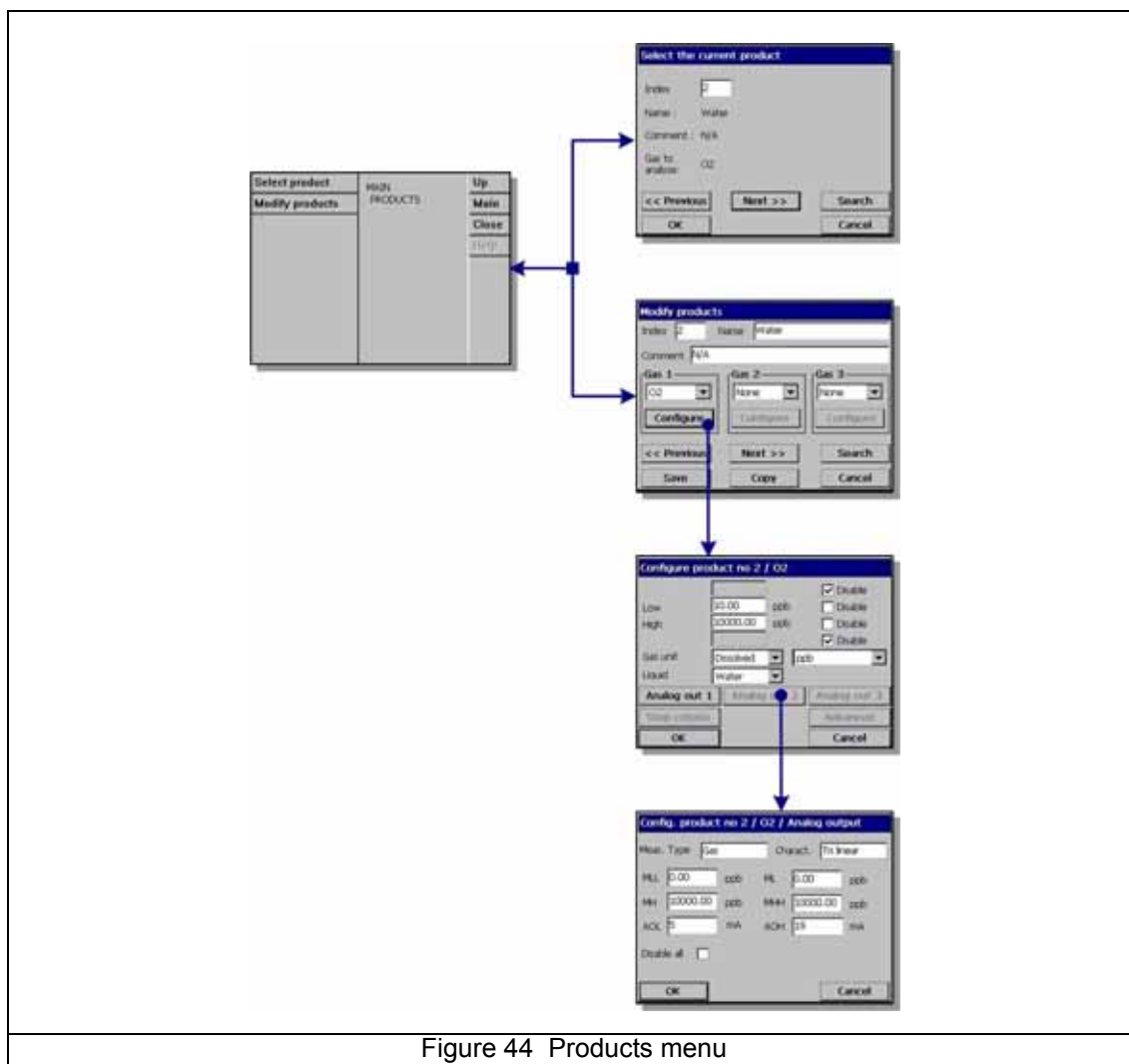

Figure 44 Products menu

### 11.1 Overview

This option allows users to save and/or use previously saved product configurations. A maximum of 100 different product configurations can be stored in the instrument. The basic measurement configuration (gas to analyze, gas unit, alarm limits, analog outputs, etc.) can be set up for a product and will be automatically used by the instrument when that product is selected.

Product configurations can be moved from instrument to instrument if required. However, as the sensor only analyzes oxygen, only products configured to analyze oxygen can be selected on this instrument. Products configured to analyze other gases can, however, be set up on this instrument and easily transferred to other 410 or 51x instruments analyzing gases other than oxygen.

For ease of use, where product configurations are identical or similar, a **Copy** facility exists on the modify product screen. This enables copying a stored configuration and storing it in one or more additional locations. Then use the modify product option to identify and/or modify the duplicate configurations.

11.1.1 Select product

*Note: If the PROFIBUS-DP communications protocol has been enabled, products can be selected for analysis using that facility (see [Input/Output data on page 79](#) and specifically [Change product command - output on page 81](#) for details).*

- Select the product (0-99) to be analyzed, or use the **Next** and **Previous** buttons to scroll sequentially through the existing product list.  
  
Alternatively, use the **Search** facility to search for a product. Enter a full or partial search criteria. If only one match is found, this product is automatically selected. If a number of products match the search criteria, then a list of matches will be displayed. Select a product directly from the list of matching products.  
  
Press **OK** to select the product or **Cancel** to exit.

11.1.2 Modify product

- Select the product (index 0-99) to modify, or use the **Next** and **Previous** buttons to scroll sequentially through the existing product list.  
  
Alternatively, use the **Search** facility to search for a product. Enter a full or partial search criteria. If only one match is found, this product is automatically selected. If a number of products match the search criteria, then a list of matches will be displayed. Select a product directly from the list of matching products.
- Select the gas to analyze (up to three can be selected) from the drop down list.  
  
After selecting a product and gas, press **Configure** to configure the product.

- Configure the product as required (refer to [Measurement configuration on page 50](#) for additional information).  
  
Press **Analog out** to configure the analog outputs, **OK** to accept the configuration as is, or **Cancel** to exit.

- Configure the analog output as required (refer to [Channel configuration on page 66](#) for additional information).  
  
Press **OK** to accept the configuration, or **Cancel** to exit.

# Section 12 Global Configuration Menu

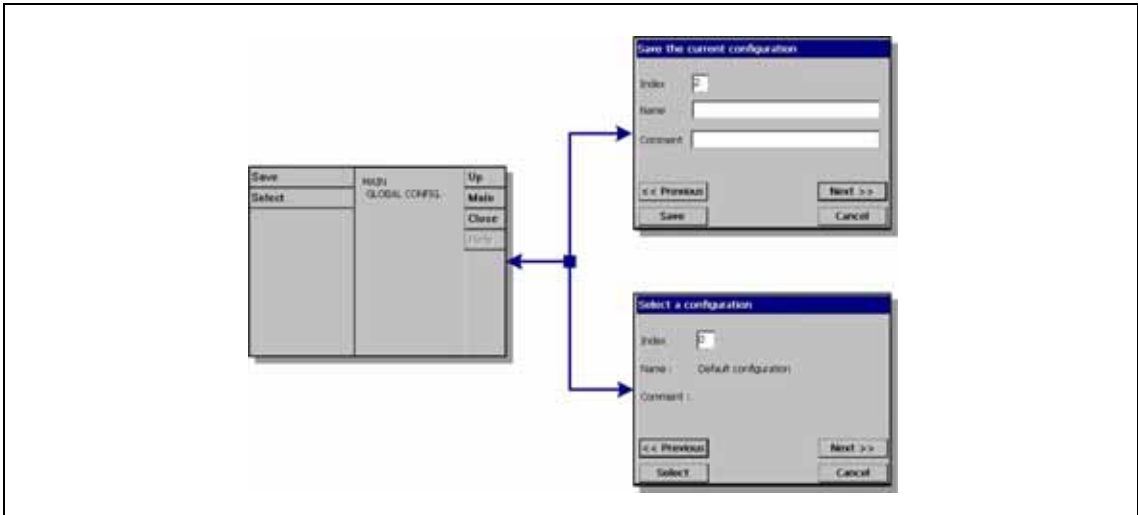

Figure 45 Global configuration menu

## 12.1 Overview

The global configuration option allows users to save, and use previously saved, instrument configurations. A maximum of 10 configurations can be saved, with configuration 0 (zero) the instrument default.

Once all the instrument parameters have been set up, use this option to save the configuration. Selecting pre-defined configurations avoids the need to re-enter all the parameters when using the instrument for a different application.

### 12.1.1 Save

The screenshot shows the 'Save the current configuration' dialog box. It has a title bar with the same text. Below the title bar are three input fields: 'Index' with a dropdown menu showing '2', 'Name' with a text box, and 'Comment' with a text box. At the bottom, there are four buttons: '<< Previous', 'Next >>', 'Save', and 'Cancel'.

- Define the index (1-9) to save the current configuration. Use the **Next** and **Previous** buttons to scroll sequentially through existing configurations, to overwrite an existing configuration or save as a new one.
- Enter a name to define the current configuration.
- Enter any comments to associate with this configuration.

### 12.1.2 Select

The screenshot shows the 'Select a configuration' dialog box. It has a title bar with the same text. Below the title bar are three input fields: 'Index' with a dropdown menu showing '0', 'Name : Default configuration', and 'Comment :'. At the bottom, there are four buttons: '<< Previous', 'Next >>', 'Select', and 'Cancel'.

- Select the configuration (index 0-9) to use on the instrument.  
Confirmation will be required for the selected configuration. The instrument must then be restarted (powered off and then back on) in order for the new configuration to take effect.





# Section 13 Services Menu

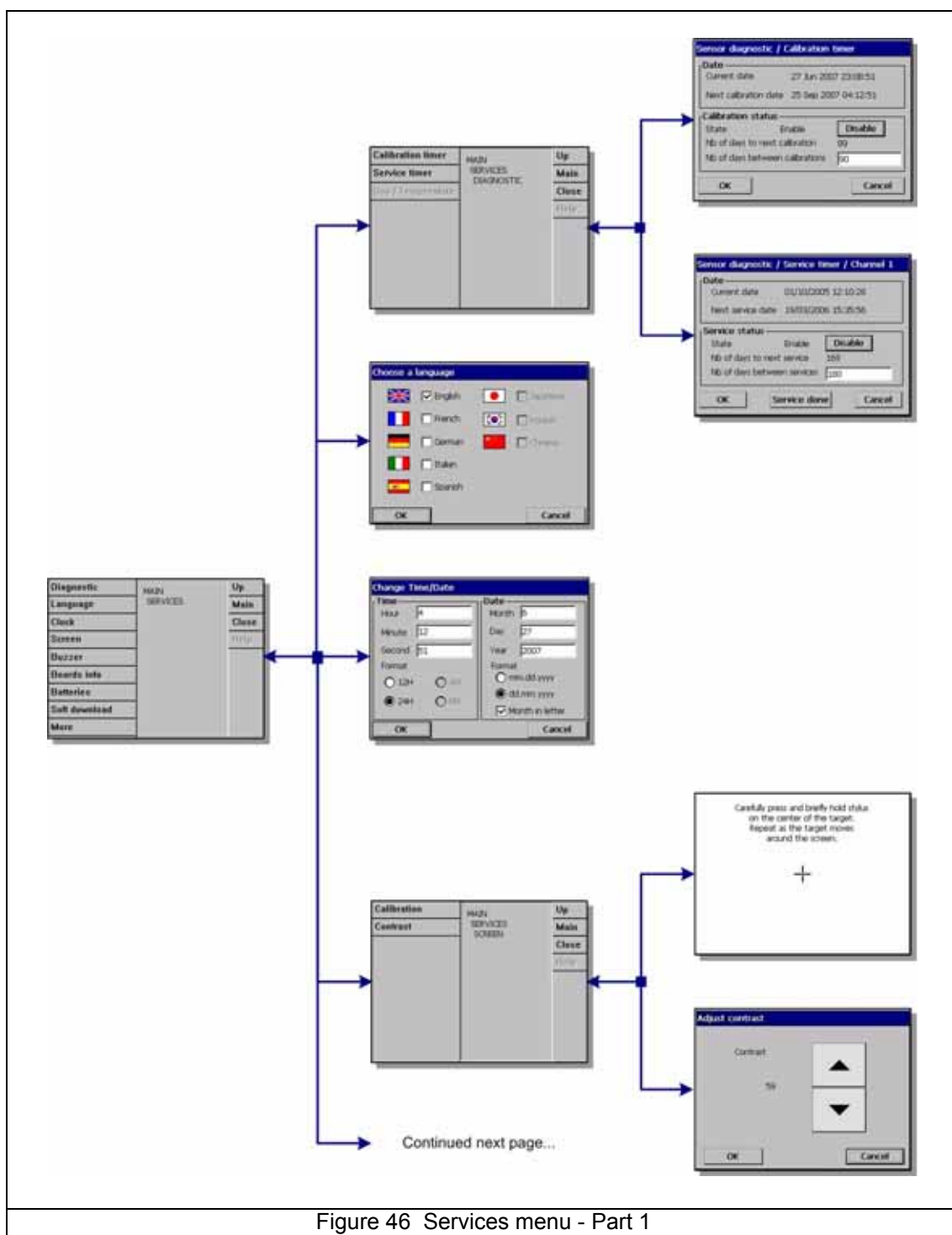

Figure 46 Services menu - Part 1

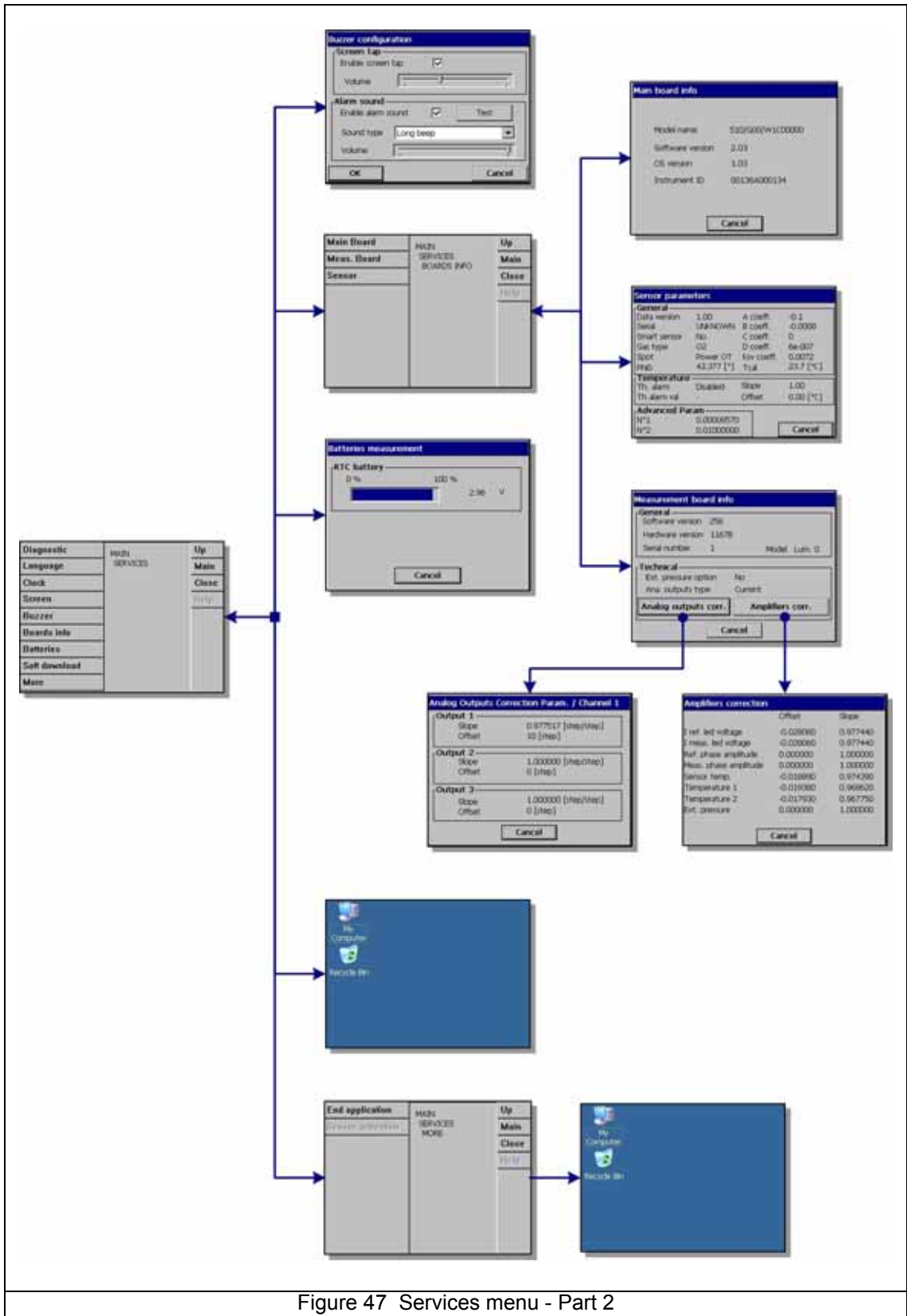
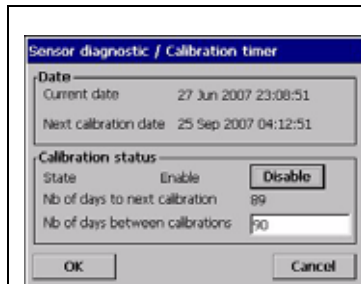

Figure 47 Services menu - Part 2

## 13.1 Sensor diagnostics

### 13.1.1 Calibration timer



The instrument can automatically remind the user when the next sensor calibration is due. This option is useful if you perform manual calibrations. However, if you have selected to automatically calibrate your instrument, this option should be disabled.

- Select enable and enter a delay in days.
- The display shows the current instrument date and time, next calibration due date and time, and the remaining days.

The next calibration date is updated when the sensor is calibrated. The event “Cal. required” is generated when the delay has elapsed.

### 13.1.2 Service timer

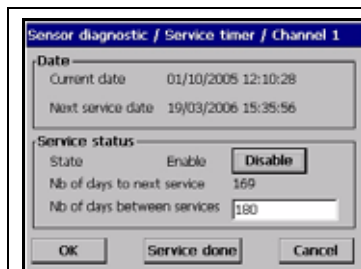

The instrument can automatically remind the user when the next sensor service is due.

- Select enable and enter a delay in days. This should be validated by a level 3 user.

The display shows the current instrument date and time, the next sensor service due date and time, and the remaining days.

The next service date is updated when the button **Service done** is pressed after a service. The event “Service required” is generated when the delay has elapsed.

The sensor(s) attached to your instrument will require periodic servicing and maintenance. For more information on this, please refer to the manual(s) delivered with the sensor(s).

## 13.2 Language selection



Check the language as required and restart the instrument to apply the change. The instrument will restart in the language selected.

**Note:** Level 3 or 4 is required to change the display language.

### 13.3 Clock

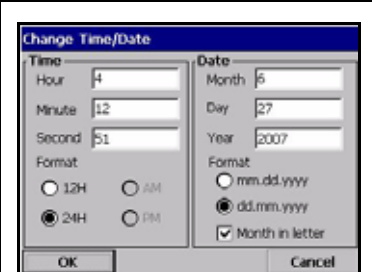

	<p>Type in each appropriate box the actual time and date, and select the display format for them.</p>
---	---

### 13.4 Screen

#### 13.4.1 Screen calibration

	<p>This Windows CE screen allows you to adjust the click position corresponding to the displayed buttons. Use it if ever the sensitive areas are no longer properly aligned with the buttons on display. Follow the instruction given on screen:</p> <p>Place the stylus right on the cross when asked and proceed. User will be asked to press on the screen to accept the new setting. If not, the new setting is not recorded and no change is made.</p>
---	---

#### 13.4.2 Screen contrast

	<ul style="list-style-type: none"><li>• Press the up or down arrow to increase or decrease the screen contrast. Press <b>OK</b> when finished.</li></ul> <p><b>Note:</b> This can also be called through the contrast icon on the main display.</p> 
---	---

### 13.5 Buzzer

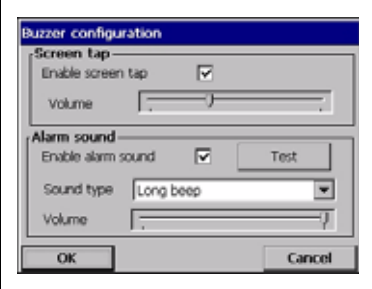
	<p>Adjust the sounds available on the instrument:</p> <p>When "screen tap" is enabled, a click sound is heard each time the screen is touched. The volume is adjustable.</p> <p>The instrument alarm sound can be enabled or disabled to suit the application. The sound type and volume can also be adjusted.</p> <p>Press the <b>Test</b> button to test the adjustment made. Press again to stop.</p>
---	--

## 13.6 Boards info

### 13.6.1 Main board info

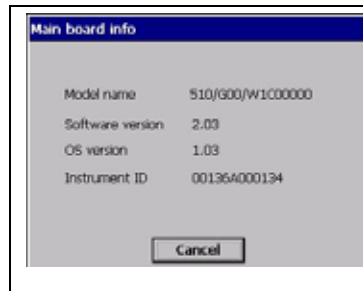

For reference, this display gives information on the instrument model, software version and instrument ID.

### 13.6.2 Measurement board info

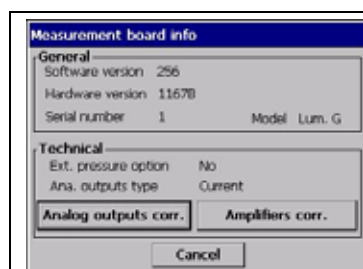

For reference, this display gives information on the sensor measurement board hardware and software.

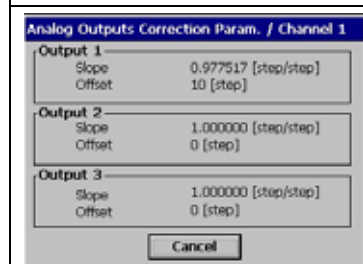

Pressing the **Analog outputs corr.** button displays for each output the correction factor that is applied.

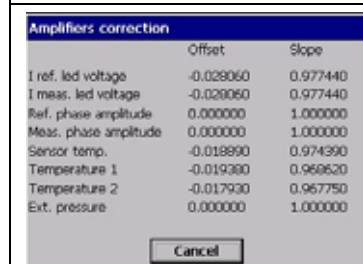

Pressing the **Amplifiers corr.** button displays the value of the actual correction factor on the amplifiers.

### 13.6.3 Sensor parameters

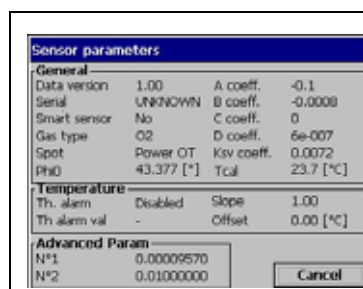

For reference this display gives information on the sensor model and type, last calibration, settings and behavior.

### 13.7 Batteries

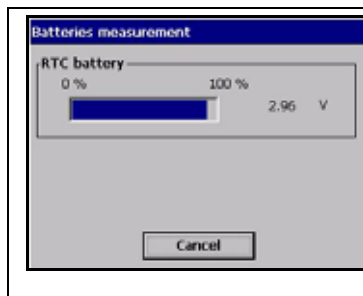

On all instruments this display gives the real time clock battery charge level and voltage.

### 13.8 Software download



For Hach Lange technician use only. Used when reloading the software for new versions.

**Note:** This ends the application. User must stop and restart the instrument to restart the program.

### 13.9 End application

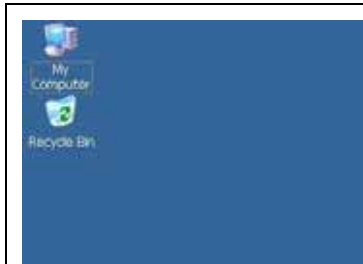

**Note:** This ends the application. User must stop and restart the instrument to restart the program.

## Section 14 Maintenance and Troubleshooting

### 14.1 Instrument maintenance

Any instrument maintenance should be carried out by a qualified Hach Lange Service Technician. Please contact your local representative should you feel any maintenance or instrument adjustments are required.

### 14.2 Sensor maintenance

The sensor spot needs to be replaced once a year. The procedure is very simple and takes no more than a few minutes.

#### 14.2.1 Equipment required

- Pair of tweezers and Maintenance tool - both supplied. Also available from kit no. 33022.
- Replacement sensor spot and O-ring - available from kit no. 33029

**Note:** Check the Ksv factor of the new spot (value found on kit 33029 box). If this is different to the Ksv value displayed in the factory parameter (see [Configure manual calibration on page 57](#)) update the factory parameter to the new value.



#### 14.2.2 Sensor spot removal

1. Using the tweezers, gently prise away the O-ring that secures the sensor spot.



2. Insert the narrow end of the maintenance tool over the sensor spot and gently squeeze to get a secure grip. Remove the spot.
3. The old sensor spot and O-ring can be discarded.



**CAUTION**  
Once the sensor spot is removed do not touch the inside of the sensor as this could scratch and damage the exposed sensitive measuring head (indicated with arrow).



### 14.2.3 Sensor spot replacement

<p>1. Take the new sensor spot and place into the end of the sensor using the maintenance tool.</p>	
<p>2. Using your fingers, put the new securing O-ring in place and push into position.</p>	
<p>3. To ensure the O-ring is properly in place, take the maintenance tool and put the large end on top of the O-ring on the sensor. Push down firmly and twist left and right a few times until the O-ring is flush with the top of the sensor.</p>	

### 14.3 Storage, handling and transportation

Protect the instrument against the elements: rain, splashing, direct sunlight, etc.

A properly packaged instrument can be stored and transported at a temperature  $-20^{\circ}\text{C}$  to  $+70^{\circ}\text{C}$  and relative humidity up to 80%. Best practice for packing the instrument for transportation is to reuse the original packaging in which the instrument was first delivered. The instrument should be stored in suitable premises, free of dust, condensation and chemical evaporation.

In cold weather, avoid sudden temperature change (like when entering a warm room) and give the instrument enough time to adapt to the ambient temperature in order to avoid condensation inside.

To clean the instrument, wipe the housing clean with a cotton cloth or tissue. Always clean the instrument before storage. Pay attention not to scratch the surface of the display to retain good clarity over time.

#### **CAUTION**

***Never use liquids such as oil, benzene, or detergents for cleaning the instrument. A mild glass cleaner can be used to remove greasy stains.***



## 14.4 Troubleshooting

The possible events, along with the text message displayed on the instrument numeric view screen, the reason for the event and its criticality are listed in [Table 3 on page 104](#). An event is something which affects the measurement. In the numeric view, the current events are indicated with the gas concentration at the same place.

Whenever an abnormal event is met, a sign is displayed on the upper left of the screen. Pressing on the sign calls a window giving further details about the actual situation.

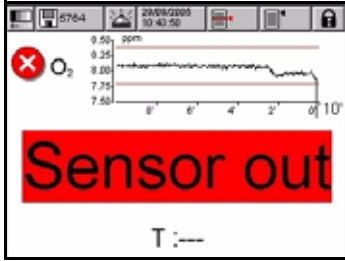
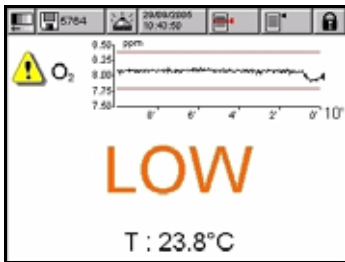
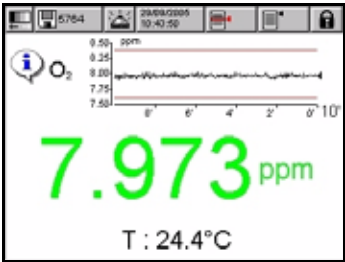

There are three levels of abnormal conditions:

	<ul style="list-style-type: none"> <li>• <b>Alarm</b> - There is a severe problem causing the channel to be out of action, and the system alarm relay to be enabled</li> </ul>
	<ul style="list-style-type: none"> <li>• <b>Warning</b> - Events less critical than a system alarm (e.g. measurement alarm)</li> </ul>
	<ul style="list-style-type: none"> <li>• <b>Information</b> - For information only; no action is required</li> </ul>

**Note:** Use the Diagnostic view for troubleshooting (see [Sensor diagnostics on page 97](#)).

## 14.5 List of events and alarms

**Table 3 List of Events**

Event type	Name	Description	Bit mask value (32 bits long)
 Information	Measure	Normal measurement mode.	0x00000000
	Filter enabled	The gas measurements are filtered.	0x00000001
	Sample measurement	The sample measurement is started.	0x00000002
	Sample measurement aborted by user	The sample measurement has been stopped manually.	0x00010000
	Sample measurement aborted by time-out	The sample measurement has stopped as the maximum time to measure a sample has been exceeded.	0x00020000
	Sample measurement aborted by sensor error	The sample measurement has stopped due to an error during the measurement.	0x00040000
 Warning	Alarm snooze	The alarm snooze is ON.	0x00000004
	Calibration	Channel in calibration.	0x00000008
	Alarm low low	Gas concentration below the Alarm LowLow limit.	0x00000010
	Alarm low	Gas concentration is below the Alarm Low limit.	0x00000020
	Alarm high	Gas concentration is above the Alarm High limit.	0x00000040
	Alarm high high	Gas concentration is above Alarm HighHigh limit.	0x00000080
	Calibration required	A calibration of the sensor is required.	0x00000100
	Service required	The sensor requires a service.	0x00000200
	Channel on hold	Channel on hold during calibration.	0x00400000
	Low level zero calibration gas	The level of zero calibration gas is very low.	0x04000000
	Auto calibration required	An automatic sensor calibration is due.	0x10000000
	Auto calibration in progress	An automatic sensor calibration is in progress.	0x20000000
	Auto calibration failed	The automatic sensor calibration has failed.	0x40000000
 Alarm	Channel disabled	The channel has been disabled.	0x00000400
	Channel out	The measurement board has been disconnected (or does not answer).	0x00000800
	Sensor out	The sensor has been disconnected.	0x00001000
	External pressure sensor out	The external pressure sensor has been disconnected	0x00002000
	Thermal cut-off	The thermal cut-off value has been exceeded	0x00004000
	Profibus-DP	The PROFIBUS-DP module has not received any measurements from the instrument for 30 secs.	0x00080000

## Section 15 Part Lists

### 15.1 Accessories and spare parts

Part N°	Description
32959	Converter RS232/RS-485. Battery powered; batteries not included
32963	Wall mounting kit
32964	Panel mounting kit
32965	Locking key for wall instruments
32970	Cap to protect USB connector
32972	Pipe mounting kit for wall instrument
32973	PROFIBUS-DP upgrade kit (includes board and software key)
32975	Power supply connector (10-30 VDC) for panel and wall instruments
33015	Pressure reducer for calibration gas bottles with 0.1 L/min. flow, 5/8" x 18 connection, max 70 bar
33016	Solenoid valve + connector for G1100-Fx flow chambers
33019	Flow cell for G1100-Fx flow chamber assemblies
33020	O-ring for G1100-Fx flow chambers
33022	Tool kit for G1x00 sensors
33029	G1200 sensor spot (nuclear version) and O-rings kit for 2 years operation
32531.03	Ethernet cable for wall and panel instruments including connectors, length = 3m
32531.10	Ethernet cable for wall and panel instruments including connectors, total length = 10 meters
32531.20	Ethernet cable for wall and panel instruments including connectors, total length = 20 meters
32533.03	USB client cable including connectors, length = 3m
32534.03	PROFIBUS-DP cable including SUB-D 9 female connector (length = 3m)
32534.MM	PROFIBUS-DP cable including SUB-D 9 female connector, total length = MM, price added per meter of length greater than 3 m.
G1200-300	Luminescent oxygen sensor for pure water applications, with 3 m cable. Nuclear version
G1100-F4	Complete flow chamber for G1x00 sensors, 1/4 inch fittings
G1100-F6	Complete flow chamber for G1x00 sensors, 6 mm fittings

## 15.2 Instrument options

A number of differently configured 510 instruments are available for use with the G1200 Sensor. The different models available are described in the following matrix:

<b>G 0 0 G1200 oxygen sensor</b>												
<b>W Wall</b>												
<b>P Panel</b>												
<b>1 100-240 VAC</b>												
<b>2 10-30 VDC</b>												
<b>C 0/4-20 mA</b>												
<b>0 RS-485</b>												
<b>1 PROFIBUS-DP / RS-485</b>												
<b>0 Standard</b>												
<b>J Japanese language</b>												
<b>K Korean language</b>												
<b>C Chinese language</b>												

5	1	0	/	G	0	0	/					0	0	0	
---	---	---	---	---	---	---	---	--	--	--	--	---	---	---	--

**Example: 510 / G00 / W1C00000**

- Analyzer model 510
- Measuring oxygen with a G1200 sensor
- Wall mounted
- 100-240 VAC
- 0/4-20 mA analog output
- RS-485
- Standard software (English, French, German, Italian and Spanish languages)

## Section 16 Glossary

### 16.1 Gas units

Unit	Meaning
% air	percentage, by weight. A concentration of 100% air corresponds to liquid saturated with air at current pressure and temperature. The equivalent concentration of O <sub>2</sub> is approximately 20% O <sub>2</sub> in normal conditions.
% O <sub>2</sub>	percentage, by weight. A concentration of 100% O <sub>2</sub> corresponds to liquid saturated with pure O <sub>2</sub> at current pressure and temperature.
%Vbar	ratio in percent between the partial pressure of gas measured and the atmospheric pressure
%Vext	ratio in percent between the partial pressure of gas measured and the external pressure. Available when an external pressure sensor is present.
µg/L	micrograms per liter
atm	atmosphere
bar, mbar	bar, millibar
cc/kg	volume of gas per kg of liquid. The volume of gas is calculated considering normal conditions (T = 0°C, p = 1atm)
g/kg	grams per kilogram
g/m <sup>3</sup>	grams per cubic meter
mg/L	milligrams per liter
ml/L	milliliters per liter
Pa, hPa, kPa	Pascal, hecto Pascal, kilo Pascal
ppb	parts per billion, by weight
ppm	parts per million, by weight (same as mg/kg)
ppm Vb	parts per million, per volume, barometric pressure referenced. = %Vbar / 10,000
ppm Ve	parts per million, per volume, external pressure referenced. = %Vext / 10,000
psia	pound per square inch, absolute
V / V	volume per volume (ratio)

### 16.2 Generic terms and definitions

Terms	Meaning
Absolute pressure	This is the total pressure in a system (i.e. relative pressure, plus atmospheric pressure)
Analog output	A voltage or current signal that is a continuous function of the measured parameter.
ASCII	American Standard Code for Information Interchange. A standard character-coding scheme used by most computers to display letters, digits and special characters.
Baud rate	Baud rate means transmission speed (Unit: bits per second, bps ), especially for RS-232/422/485 interfaces.
CIP	Cleaning In Progress
Concentration	The relative content of a component in a gaseous or liquid media.
Conductivity	The reciprocal of electrical resistivity.
FIFO (First In First Out)	FIFO is a concept to describe the behavior of a buffer. It means the data which entered first will exit first.
Headspace	The empty volume above a liquid or solid in a closed container.

## Glossary

---

Master / Slave modes	A device operating as a master will poll one or more devices operating as a slave. This means a slave device cannot volunteer information; it must wait to be asked for it.
Parallel communication	Parallel communication represents a connection in a computer system in which the bits of a byte are transmitted over separate channels at the same time.
PLC	Programmable Logic Controller. It communicates with other process control components through data links. It is used in process control for simple switching tasks, PID control, complex data manipulation, arithmetic operations, timing and process and machine control.
PROFIBUS-DP	The PROFIBUS-DP (Decentralized Peripheral) fieldbus is designed especially for communication between automation control systems and distributed I/O at the device level. Each DP device has specific parameters such as device version, baud rate, data format, I/O length, user parameters, etc. These parameters are stored in a file with .GSD extension.
PROFIBUS-DP GSD files	The GSD file is provided by the manufacturer and is required for device configuration. A GSD file is a readable ASCII text file that contains both general and device-specific specifications for communication (Communication Feature List) and network configuration.
Relative pressure	Relative pressure is the over pressure in a system (i.e. absolute pressure less atmospheric pressure). This is the customary gauge reading.
Resistivity	The opposition offered by a body or substance to the passage through it of a steady electric current.
RS-232	RS-232 is a serial communication standard providing asynchronous communication capabilities with hardware flow control, software flow control, and parity check. Maximum transmission distance is up to 15 meters at a max. 20,000 bps. A converter is required to interface RS-232 with RS-422 or RS-485.
RS-422	RS-422 is intended for point-to-point communications. It provides much longer transmission distance but less signal line compares to RS-232. RS-422 adopts differential transmission technology and thus provides high-speed transmission up to 10mbps and maximum transmission distance up to 1.2km/110kbps.
RS-485	RS-485 is an enhanced version of RS-422 and is used for multipoint communications, meaning that many devices may be connected to a single signal cable. It is compatible to RS-422 interface and provides 2 wire bus topology.
Serial communication	Serial communication represents a connection in a computer system in which the bits of a byte are transmitted sequentially over a single wire.
Single twisted pair	In this version, all devices are connected to a single Twisted Pair. Thus, all of them must have drivers with tri-state outputs (including the Master). Communication goes over the single line in both directions. It is important to prevent more devices from transmitting at once (software problem).
USB	Universal Serial Bus. An external peripheral interface standard for communication between a computer and external peripherals over a cable using bi-serial transmission. The USB host uses a type A connector, and the USB peripheral uses a type B connector.



