

Sigma 950 Series Permanent/Portable Open Channel Flow Meters

Sigma 950 Series Permanent/Portable Open Channel Flow Meters provide portable and/or permanent single-channel monitoring plus water quality testing, process control interface, and digital display. Both models offer maximum flexibility for multiple applications—including surcharge or reversed flow conditions, weirs and flumes, and small-to-large channels. Up to three different level sensor technologies and velocity in one meter.



Features and Benefits

Versatility and Customization

The Sigma 950 series are the meters of choice by flow professionals, consultants, and municipalities. Choose from any of the following technologies to fit your application.

- Use the Submerged Area/Velocity flow meter to measure flow in collections systems for periods up to 40 days using our 6 amp-hr gel electrolyte battery.
- Use any of our level technologies when primary devices (Weirs and Flumes) are available to measure level and calculate flow.
- The bubbler level technology is ideal for applications with high winds, high temperature or when foam is present.
- The combination of bubbler level technology and doppler velocity is the favorite of storm water professionals.
- The ultrasonic level technology is ideal to monitor industrial discharges for your Pre-treatment program in combination of any of our Automatic Wastewater samplers.

Sampler Pacing and Equipment Control

Control samplers, pumps, or other equipment for monitored flow based on selected parameter(s) of high/low set points and built-in relay outputs. Sampler pacing provides the ability to document overflow problems.

Easy to Use Interface

The large LCD graphics quickly displays information on-site (available in 10 languages) without the inconvenience of paper charts. The built-in keypad makes using laptops in the field optional. A single keystroke can provide an instantaneous data summary and review of all program settings.

Communications and Data Storage Options

Industry standard SCADA MODBUS ASCII protocol is included in all Sigma 950 flow meters. 4-20 mA outputs are available for flexible integration with a SCADA system. Remote communications is available via modem or RS-232 connection. Store 18,000 data points in memory (expandable to 116,000 data points).

Superior Submersible Area Velocity Sensor for Open Channel Applications

The Sigma 950 AV Optiflo flow meter provides Doppler velocity monitoring that uses advanced ultrasonic, one-MHz Doppler technology for flow measurements. This technology avoids signal dropouts and ensures high levels of accuracy in low-flow, full-pipe, or reversed-flow conditions. Installation is fast and single point atmospheric calibration is easy.

Applications

Sigma 950 Permanent/Portable Open Channel Flow Meter

- Long term or permanent flow studies
- Sanitary sewer evaluation studies
- CSO studies and monitoring
- NPDES stormwater compliance
- Industrial compliance monitoring

Sigma 950 AV Optiflo Permanent/Portable Open Channel Flow Meter

- Applications involving frequent moving of meter to different site conditions

DW = drinking water WW = wastewater municipal PW = pure water / power
IW = industrial water E = environmental C = collections FB = food and beverage



Be Right™

WW

IW

C

Specifications*

Flow Meter Specifications

Units of Measurement

Flow: gps, gpm, gph, lps, lpm, lph, mgd, afd, cfs, cfm, cfh, cfd, m³s, m³m, m³h, m³d

Totalized Flow: L, m³, ft.³, gal., acre-ft.

Primary Devices

Flumes: Parshall, Palmer Bowlus, Leopold-Lagco, H, HL, HS, trapezoidal
Weirs: V-notch (22.5 to 120°)
Contracted/non-contracted rectangular, Thelmar, Compound Cipolletti
Manning Equation: Round, U rectangular, and trapezoidal channels
Flow Nozzles: California Pipe
Head vs. Flow: Custom programmable curve (up to 99 points)

Operating Temperature

-10 to 65.5°C (14 to 150°F)

Storage Temperature

-40 to 80°C (-40 to 176°F)

Humidity

0 to 100%, condensing

Time-Based Accuracy

±6 seconds (± 0.007%) per day

Air Intake

Atmospheric pressure reference is desiccant protected

Totalizers

8-digit resettable and 8-digit non-resettable LCD software totalizer
Optional 6-digit non-resettable mechanical totalizer

Sensor Specifications

950 BUBBLER SENSOR

Range

0.003 to 3.6 m (0.01 to 11.75 ft.)

Accuracy

±0.003 m (±0.011 ft.)
(linearity and hysteresis at 22°C (72°F))
from 0.01 to 11.75 feet

Ambient Operating Temperature

-18 to 63°C (0 to 145°F)

Compensated Temperature

0 to 59°C (32 to 138°F)

Temperature Error

±0.0003 ft./°F (maximum error within compensated temperature range per degree of change)

Air Intakes

Bubble source and reference port desiccant protected.
Fittings provided for remote intakes.

Graphics Display

Back lit LCD
Auto-off when not in use (under battery operation)
SCII Mode: 8 line x 40 character
Graphics Mode: 60 x 240 dot
Dimensions: 3.8 x 12.7 cm (1.5 x 5 in.)
Displays: level vs. time, flow vs. time
Optional Displays: rainfall, pH, ORP, temperature, DO, conductivity vs. time, sampler events, and alarm events

Keypad

21 position sealed membrane switch with blinking green LED to indicate power on
Four "soft keys", functions defined by display

Data Logging

"Smart" Dynamic memory allocation automatically partitions memory to provide the maximum logging time. No manual memory partitioning required.

Memory Mode: Either slate or wrap-around may be selected

Data Points: Approximately 20,000 standard. Expandable up to 116,000 data points.

Daily Statistics: Available for up to 32 days

Recording Intervals: 1, 2, 3, 5, 6, 10, 12, 15, 20, 30, or 60-minute intervals

Program Memory

Non-volatile programmable flash, can be updated via RS-232 port

Sampler Output

12 to 17 Vdc pulse, 100 mA maximum at 500 ms duration

Communications

RS-232: Up to 19,200 baud
SCADA MODBUS communication protocol via RS-232 or optional modem
Modem (optional): 14,400 bps; V.32 bis, V.42, MNP2-4 error correction. V.42 bis MNP5 data compression. MNP 10-EC Cellular Protocol Pager

Enclosure Material

ABS, UV resistant

Enclosure Rating

NEMA 4X,6

Power Options

12 Vdc supplied from 6 amp-hr. gel electrolyte rechargeable battery
4 amp-hr. Ni-Cad rechargeable battery
Lantern battery pack with two 6-Volt lantern batteries
115 Vac, 230 Vac, or 100 Vac power converter with battery charger

Dimensions

34.3 H x 25.4 W x 24.1 D cm
(13.5 x 10.0 x 9.5 in.)

Weight

5 kg (11 lbs.) not including power source

Filter

10 micron on bubble source intake

Line Purge

Bubble line is high pressure purged at programmed intervals, or in manual mode on demand

Line Size

0.32 cm (1/8 in.) ID standard

Line Lengths

160 m (500 ft.) maximum

950 DOWNLOOKING ULTRASONIC DEPTH SENSOR

50 kHz Ultrasonic Sensor

Range

38.1 cm to 9.1 m (15 in. to 30 ft.) sensor to liquid

Accuracy

1 to 10 ft. ±0.01 ft. (±0.003 m)
(at 22°C (72°F), still air, 40 to 70% relative humidity)

Span

0 to 8.84 m, (0 to 29 ft.)

Ambient Operating Temperature

-18 to 60°C (0 to 140°F)

Temperature Error

±0.000047 ft./°F (maximum error within compensated temperature range per degree of change)

Resolution

0.0011 ft.

Material

PVC housing
Buna-N acoustic window

Cable

4-conductor with integral stainless steel support cable
Standard Length: 7.6 m (25 ft.)

Continued on next page.

Specifications *continued*

Crystal Specification

11.5° included beam angle

Dimensions

9.5 H x 7 D cm (3.75 x 2.75 in.)

Weight

0.7 kg (1.5 lbs.)

75 kHz Ultrasonic Sensor

Range

23 cm to 3.3 m (9 in. to 10.8 ft.)
sensor to liquid

Accuracy

1 to 10 ft. ± 0.01 ft. (± 0.003 m)
(at 22°C (72°F), still air, 40 to 70%
relative humidity)

Span

0 to 4.57 m (0 to 15 ft.)

Ambient Operating Temperature

-18 to 60°C (0 to 140°F)

Temperature Error

± 0.000047 ft./°F (maximum error within
compensated temperature range per
degree of change)

Resolution

0.0011 ft.

Material

PVC housing
Buna-N acoustic window

Cable

4-conductor with integral stainless steel
support cable
Length: 7.6 m (25 ft.) standard

Crystal Specification

5° beam angle with horn

Dimensions

12.7 H x 5.7 D cm (5.0 x 2.25 in.)

Weight

0.7 kg (1.5 lbs.)

75 KHZ IN-PIPE ZERO DEADBAND ULTRASONIC DEPTH SENSOR

Range

From sensor to liquid,
0 to 2.4 m (0 to 8 ft.)

Accuracy

0.038 to 2.4 m ± 0.003 m
(0.125 to 8 ft. ± 0.01 ft.)
at 22°C (72°F), still air, 40 to 70%
relative humidity

Span

0.038 to 4.57 m (0.125 to 15 ft.)

Ambient Operating Temperature

-18 to 60°C (0 to 140°F)

Temperature Error

± 0.00005 m/°C (± 0.0001 ft./°F)
maximum error within compensated
temperature range per degree of change

Resolution

0.019 cm (0.0075 in.)

Material

Stat-Kon® A-E ABS Plastic

Cable

4-conductor
Standard Length: 7.6 m (25 ft.)
Custom Length: Up to 305 m (1000 ft.)
using RS485 two wire remote sensor
option

Crystal Specification

7° beam angle

Dimensions

4.44 D x 31.5 L cm (1.75 x 12.4 in.)

Connection

Bare lead connection via 3658 junction
box or quick connect

950 SUBMERGED DEPTH ONLY SENSOR

Range

2.5 psi: 0.01 to 1.75 m (0.04 to 5.75 ft.)

Accuracy

$\pm 0.1\%$ full scale (non-linearity and
hysteresis)

Transducer

Type: Differential piezo resistive with
balanced bridge
Orientation: Inverted

Maximum Allowable Level

6x over pressure

Ambient Operating Temperature

0 to 71°C (32 to 160°F)

Compensated Temperature

0 to 36°C (32 to 96°F)

Temperature Error:

2.5 psi: 0.04 to 5.75 ft. ± 0.006 ft./F°
(Max error within compensated temp
range per degree of change)

Air Intake

Atmospheric pressure reference is
desiccant protected

Material

316 stainless steel body with titanium
diaphragm

Cable

4-conductor polyurethane sensor
cable with air vent
Length: 7.6 m (25 ft.) standard;
76 m (250 ft.) maximum

Dimensions

Transducer Only: 2.54 x 17.2 cm
(1 x 6.75 in.)
Probe Frontal Area: 0.875 in²

Weight

0.7 kg (1.5 lbs.)

SUBMERGED AREA/VELOCITY SENSOR

Velocity Measurement

Method

Doppler ultrasound Twin 1 MHz
piezoelectric crystals

Accuracy¹

$\pm 2\%$ of reading

Recommended Range

-1.52 to 6.10 m/s (-5 to 20 ft/s)

Typical Minimum Depth

2 cm (0.8 in.)

Zero Stability

< 0.015 m/s (< 0.05 ft/s)

Depth Measurement

Method

Pressure transducer with stainless steel
diaphragm

Accuracy²

$\pm 0.16\%$ full scale $\pm 1.5\%$ of reading at
constant temp ($\pm 2.5^\circ\text{C}$)
 $\pm 0.20\%$ full scale $\pm 1.75\%$ of reading
from 0 to 30°C (32 to 86°F)
 $\pm 0.25\%$ full scale $\pm 2.1\%$ of reading from
0 to 70°C (32 to 158°F)

Depth Range

Standard: 0 to 3 m (0 to 10 ft.)
Extended: 0 to 9 m (0 to 30 ft.)

Maximum Allowable Depth

Standard: 10.5 m (34.5 ft.)
Extended: 31.5 m (103.5 ft.)

Velocity-Induced Depth Error

Compensated based on pipe geometry
and flow velocity

Air Intake

Atmospheric pressure reference is
desiccant protected

¹When the sensor is out of the water, the system may report
velocity readings of up to 0.76 m/s due to Radio Frequency
Interferences at frequencies of 140 MHz to 170 MHz and 300
MHz with field strengths greater than 3 V/m.

²For temperatures above 40°C (104°F) add ± 0.3 cm/°C
(0.03 in./°F)

Continued on next page.

Specifications *continued*

General

Material

Noryl® plastic outer shell with epoxy potting within

Power Consumption

≤ 1.2 W @ 12 Vdc

Cable

Material: Urethane cable with air vent
Standard Length: 9, 15, 23 and 30.5m (30, 50, 75 and 100 ft.)
Custom Length: 30.75 to 76 m (101 to 250 ft.) maximum
Diameter: 0.91 cm (0.36 in.)

Dimensions

2 H x 3.8 W x 13.5 L cm
 (0.8 x 1.5 x 5.31 in.)

Operating Temperature

0 to 70°C (32 to 158°F)

Depth Compensated Temperature

0 to 70°C (32 to 158°F)

BUBBLER AREA/VELOCITY SENSOR

Depth Measurement

Method

Doppler principle/pressure transducer

Range

0.003 to 3.6 m (0.01 to 11.75 ft.)

Accuracy

0.01 to 11.75 ft. ±0.011 ft. (0.033 m)
 (linearity and hysteresis at 22°C (72°F))

Ambient Operating Temperature

-18 to 63°C (0 to 145°F)

Compensated Temperature

0 to 59°C (32 to 136°F)

Temperature Error

±0.0003 ft./°F (maximum error within compensated temperature range per degree of change)

Air Intakes

Bubble source and reference port desiccant protected.
 Fittings provided for remote intakes.

Filters

10 micron on bubble source intake

Line Purge

Bubble line is high pressure purged at programmed intervals, or in manual mode on demand

Velocity Measurement

Method

Doppler ultrasonic

Transducer Type

Twin 1 MHz piezoelectric crystals

Range

-1.52 to 6.10 m/s (-5 to 20 fps)

Zero Stability

< 0.015 m/s (0.05 fps)

Accuracy

±2% of reading

Depth for Velocity

2 cm (0.8 in.) minimum, typical

Operating Temperature

-18 to 60°C (0 to 140°F)

Dimensions

1.12 x 3.81 x 6.86 cm
 (0.44 x 1.5 x 2.7 in.)

LOW PROFILE VELOCITY ONLY SENSOR

Method

Doppler principle

Accuracy

±2% of reading

Range

-1.52 to 6.1 ms (-5 to +20 ft/s)

Zero Stability

±1.52 cm/s (±0.05 ft/s)

Resolution

0.3 cm/s (0.01 ft/s)

Response Time

4.8 seconds

Profile Time

4.8 seconds

Nose Angle

20° from horizontal

Cable

Length: 7.6 m (25 ft.) standard; custom cable lengths to 76 m (250 ft.)
Diameter: 0.57 cm (0.225 in.)

Materials

Sensor: Polymer

Cable: Urethane Jacket

Mounting Hardware: Stainless steel

Dimensions

6.86L x 3.81W x 1.12H cm
 (2.7 x 1.5 x 0.44 in.)

Continued on next page.

Specifications *continued*

Factory Installed Options

pH-TEMPERATURE OR ORP METER

Control/Logging

Log pH-temperature or ORP independent of flow or in conjunction with flow; also controls sample collection in response to value exceeding low/high set points

pH/Temperature Sensor

Temperature compensated; impact resistant ABS plastic body; combination electrode with porous Teflon[®] junction

Measurement Range

2 to 12 pH within specifications; 0 to 14 pH maximum range

Operating Temperature

-18 to 80°C (0 to 176°F)

Recording Intervals

1, 2, 3, 5, 6, 10, 12, 15, 30, and 60 minutes

Probe Pre-Amplifier/Junction Box

NEMA 4X with labeled terminal strip

Dimensions

1.9 x 15.2 cm (0.75 x 6 in.) with 1.9-cm (0.75-in.) MPT cable end

RAIN GAUGE INPUT

For use with Hach Tipping Bucket Rain Gauge. Flow Meter records rainfall data in 0.01 in. increments.

ANALOG INPUT CHANNELS

Up to seven additional data-logging channels record data from external source(s)
Field assignable units
-4.5 to +4.5 Vdc; ±0.5% full scale voltage accuracy
0 to 20 mA; ±0.2% full scale 4-20 mA accuracy with 200 ohm impedance

4 - 20 MA OUTPUTS

Up to two integral user assignable outputs
Optically isolated
Up to 600 ohm load per output
0.1 % FS error
24 Vdc - no load
Insulation voltage between flow meter and 4-20 mA output - 2500 Vac, between the two 4-20 mA outputs - 1500 Vac

ALARM RELAYS

(4) 10 amp/120 Vac or 5 amp/250 Vac form C relays
User assignable for any internal or external data channel or event

MECHANICAL TOTALIZER

6-digit non-resettable mechanical totalizer
Selectable units: gal., liters, ft.³, m³, acre-ft.

MODEM

14,400 baud rate
CRC auto to check sum
FCC approved
Cellular compatible

EXPANDED MEMORY

Increase memory from 18,432 data points to 116,736 data points

AC POWER BACKUP

Provides power in the event of an AC power failure
Internal trickle charger maintains 6 amp-hour battery

Teflon[®] is a registered trademark of E.I. DuPont de Nemours Inc.

Noryl[®] is a registered trademark of the General Electric Company.

**Specifications subject to change without notice.*

Engineering Specifications

Flow Meter

1. The flow meter shall operate on 12 Vdc, which is supplied by a battery or 115 Vac power converters.
2. All electrical components shall be enclosed in a NEMA 4X-6 enclosure. The enclosure shall have a continuous hinged front cover to protect the display and keypad and shall maintain NEMA 4X,6 with the cover open.
3. The enclosure shall contain desiccant and a front panel humidity indicator.
4. Current data shall be displayed on the flow meter front panel by means of an external push button on the enclosure. The meter shall not require opening of a cover to see current status.
5. The meter shall have an 8 line x 40-character backlit liquid crystal graphics display. In addition to indicating all programming steps and current status such as level, velocity and flow rate, the display shall show all logged data in field selectable tabular and graphics (x-y plot) formats.
6. All program entries shall be entered via a sealed front panel keypad, and indicated on the front panel display. The keypad and display shall meet NEMA 4X-6 standards.
7. A personal computer or any other external means shall not be required to program the flow meter or integral logger or to access data.
8. Flow meter programming/measurements:
 - a. The flow meters shall be field programmable for primary devices including:
 - i. Weirs: V-notch weirs (any angle from 22.5 to 120 degrees, compound V-notch/rectangular weirs, contracted and non-contracted rectangular weirs, trapezoidal weirs, and ThelMar weirs.
 - ii. Flumes: Parshall (1 to 144 inch), Palmer Bowlus (4 to 72 inch), trapezoidal (60 degree small, large, and extra large, 45 degree 2 and 12 inch), H. HL, and HS type flumes, and Leopold-Lagco (4 to 72 inch).
 - iii. Nozzle: California pipe method; Manning equation for round, U-channel, rectangular, and trapezoidal cross sections; power curve equation.
 - iv. Head vs. flow tables: Two tables of up to 99 (head, flow) points per table (tables may be stored in flow meter's memory and retrieved as required).
 - b. Field selectable units of measurement shall include:
 - i. Level: Inches, feet, centimeters, and meters.
 - ii. Flow rate: GPS, GPM, GPH, MGD, AFD, LPS, LPM, LPH, CFS, CFM, CFH, CFD, CMS, CMM, CMH, CMD.
 - iii. Total flow: Gallons, cubic feet, acre-feet, liters, and cubic meters.
9. Flow totalizing:
 - a. The flow meter shall have two software totalizers, one resettable and the other resettable.
 - b. (Optional) The meter shall include a 6-digit non-resettable electro-mechanical totalizer, protected to meet NEMA 4X, 6 standards.
10. Sampler pacing:
 - a. The flow meter shall have a 12 Vdc pulse output for pacing an automatic liquid sampler in proportion to flow, with field selectable flow volume between pulses.
 - b. The meter shall be capable of initiating a sampler on level, flow rate, and flow rate of change.
11. Integral metering devices (optional):
 - a. The meter shall be equipped with an integral pH-temperature/ORP meter. The pH meter shall have a range of 0 to 14 pH with a $\pm 1\%$ resolution over an operating range of 0 to 176 degrees F.
 - b. The meter shall be equipped with an integral temperature meter. The temperature meter shall have an operating range of 0 to 176 degrees F. The meter shall include a platinum RTD probe in a stainless steel body with 25-foot cable.
 - c. The meter shall be equipped with a rain gauge input. The sampler shall accept contact closure inputs from an external rain gauge.
 - d. The meter shall be equipped with seven external analog inputs. The first four channels shall be capable of logging a 4-20 mA current input, and the remaining three channels shall be set up to log -4.5 to +4.5 Vdc voltage input.
12. The flow meter and sensor shall be the Sigma Model 950 Permanent/Portable Open Channel Flow Meter OR Sigma Model 950 AV Optiflo Permanent/Portable Open Channel Flow Meter manufactured by Hach Company.

Dimensions

Placement of Sigma 950 Series Permanent/Portable Open Channel Flow Meters depends on the suitability of the monitoring site. Select sites that have normalized flow and minimal turbulence. Turbulence can make it difficult to detect an average velocity in the flow stream. Obstructions, vertical drops, pipe bends, and elbows can create turbulence and affect the accuracy of measurements. Mounting options for Sigma 950 flow meters include wall mounting, suspension harness installation, or manhole rung hanger.

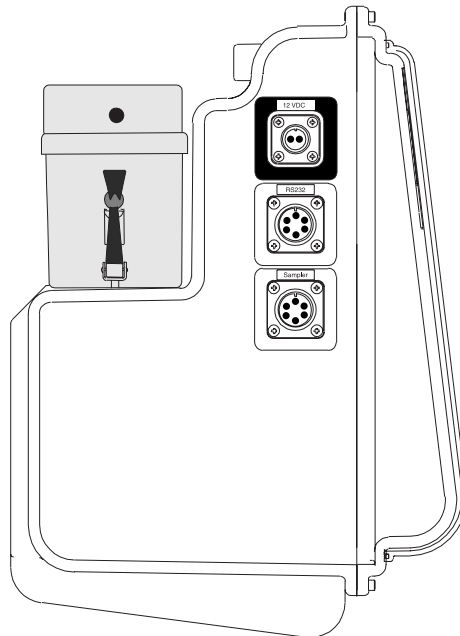
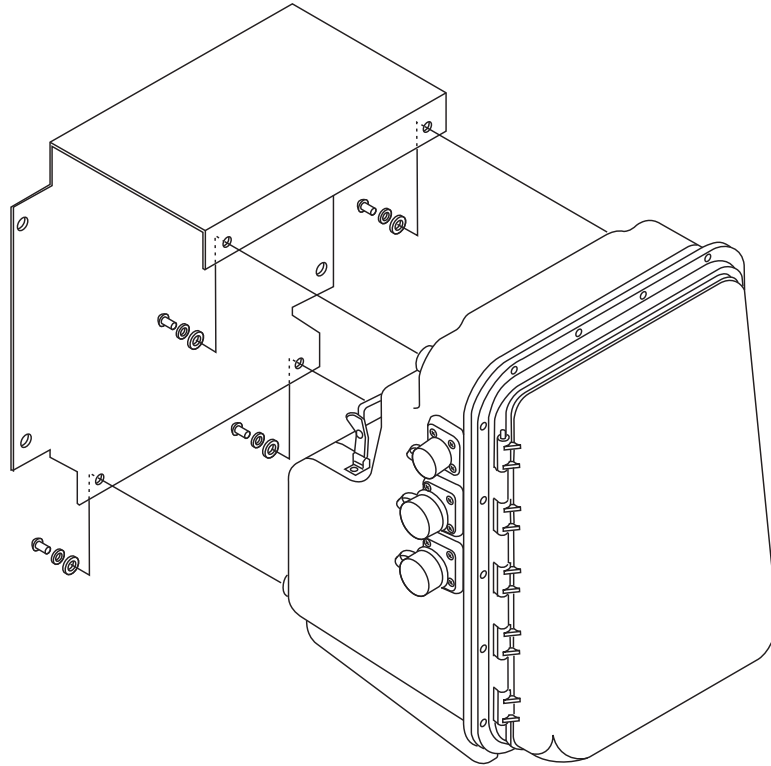

Ordering Information

Complete Flow Meter Systems

3672950	950 Bubbler Flow Meter; includes 25 ft. tubing
3680950	950 Submerged Pressure Flow Meter; includes 25 ft. sensor cable
3286951	950 75 kHz Down-look Ultrasonic Flow Meter; includes 25 ft. sensor cable
3286952	950 75 kHz In-Pipe Ultrasonic Flow Meter; includes 25 ft. sensor cable
3248950	950 Bubbler AV Flow Meter; includes 25 ft. of sensor cable
3522950	950 Submerged AV Flow Meter; includes 25 ft. of sensor cable
3959952	950 75k Hz Ultrasonic AV Flow Meter with In Pipe Ultrasonic and Velocity Sensors

Integral Water Quality Options and Sensors

2684	Factory Installed Integral pH-Temp/ORP Sensor; includes pre-amp interface
3328	pH-Temperature Sensor (grounded); includes 25 ft. cable
2080	ORP Sensor; includes 25 ft. cable
3216	DO Probe Kit; includes 25 ft. cable.
3225	Conductivity Probe Kit; includes 25 ft. cable
3222	DO Probe only; includes 25 ft. cable
3223	Conductivity Probe only; includes 25 ft. cable

Communication and Control Interfaces

2676	First 4-20 mA Output; includes 25 ft. cable
2923	Second 4-20 mA Output
2691	First Set Two (2) Alarm Relays with settable trip points
2707	Second Set Two (2) Alarm Relays with settable trip points
4578	Modem; 14,400 baud (domestic lines only)

Sensor Mounting Hardware

1361	Spring Ring for 6-in. diameter pipe
1362	Spring Ring for 8-in. diameter pipe
1363	Spring Ring for 10-in. diameter pipe
1364	Spring Ring for 12-in. diameter pipe
3263	Sensor Mounting Clip; for 88000, wafer velocity, and bubbler level velocity sensors
3868	Portable Bracket; for in-pipe ultrasonic sensor mounting clip
3875	Permanent In-Pipe Ultrasonic Sensor Mounting Bracket
3305	Velocity Sensor Mounting Plate
9574	Insertion Tool; for non-confined space entry
2974	Permanent Wall Mount Bracket; for down-looking ultrasonic sensor
2904	Floor or Wall Adjustable Mounting Bracket; for down-looking ultrasonic sensor
9538	Tripod Mounting Bracket; for down-looking ultrasonic sensor
2883	Cable Straightener; for down-looking ultrasonic sensor
3183	Cable Grip; for down-looking ultrasonic sensor

Cables and Interfaces

1727	Sampler or Flow Meter to PC Cable
3358	RS232 Extension Cable

Accessories

77247-00	Silicon Oil; dual 50-ml pack (refills 100 sensors)
77248-00	Silicon Oil Refill Kit; includes dispensing tool and oil packs
77256-00	Oil-Filled Sub-AV Sensor Kit
77300-00	Retrofit Kit (converts non oil-filled to oil-filled); includes Silicon Oil Refill Kit

At Hach, it's about learning from our customers and providing the right answers. It's more than ensuring the quality of water—it's about ensuring the quality of life. When it comes to the things that touch our lives...

Keep it pure.

Make it simple.

Be right.

For current price information, technical support, and ordering assistance, contact the Hach office or distributor serving your area.

In the United States and all other countries, contact:

HACH COMPANY
5600 Lindbergh Drive
Loveland, CO 80539 U.S.A.
Telephone: 800-368-2723 / 970-622-7120
Fax: 970-619-5150
E-mail: hachflowsales@hach.com
www.hachflow.com

