



DOC023.53.03231

ULTRATURB ***seawater sc***

User Manual

05/2024, Edition 10

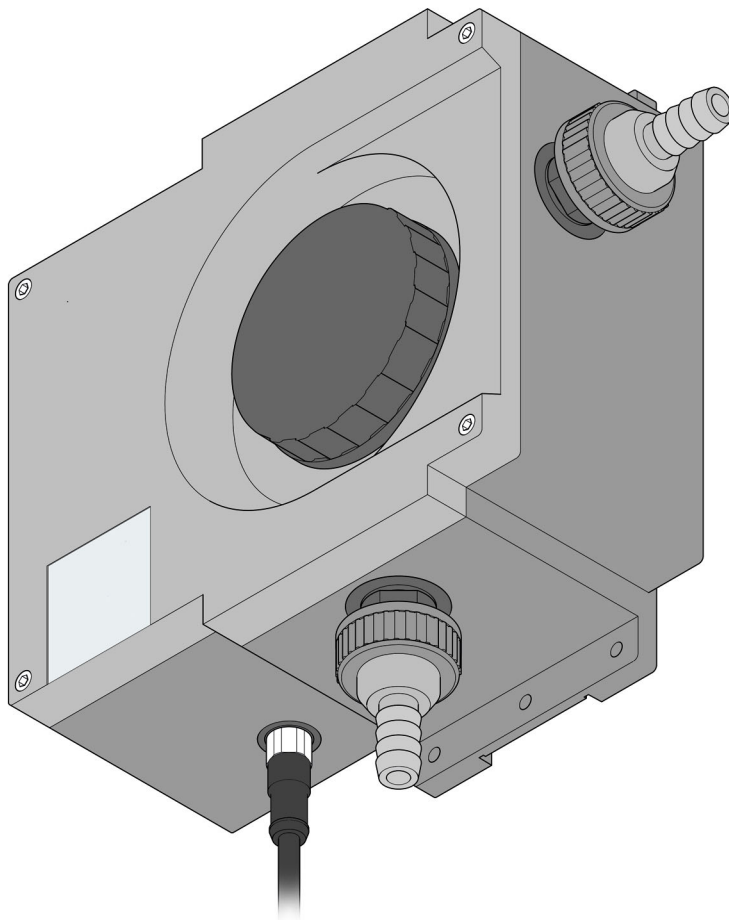

Table of contents

Section 1 Specifications	5
1.1 Dimensions	6
Section 2 General information	7
2.1 Safety information	7
2.1.1 Use of hazard information	7
2.1.2 Precautionary labels	8
2.2 Applications	9
2.3 Measuring principle	9
2.4 Handling	9
2.5 Items supplied	10
2.6 Function check	10
Section 3 Installation	11
3.1 Assembling	11
3.1.1 Connectors	12
3.2 Instrument layout	13
3.3 Connecting sensor cable	14
Section 4 Operation	15
4.1 Operating the sc controller	15
4.2 Sensor setup	15
4.3 Sensor data logger	15
4.4 Menu structure	15
4.4.1 SENSOR DIAG	15
4.4.2 SENSOR SETUP	16
4.5 Calibration with standard solution	18
4.6 Verify using verification standard	19
4.7 Zero point setting	19
Section 5 Maintenance	21
5.1 Maintenance schedule	21
5.2 Cleaning measuring chamber	21
5.3 Replacing wiper profiles	22
5.4 Replacing desiccant	23
5.5 Monitoring test equipment	24
5.5.1 Preparing formazine solution in accordance with ISO 7027-1:2016	24
Section 6 Faults, causes, rectification	27
6.1 Error messages	27
6.2 Warnings	27
Section 7 Replacement parts and accessories	29
7.1 Sensor options	29
7.2 Replacement parts	29
7.3 Accessories	29

Section 1

Specifications

Specifications are subject to change without notice.

Components	Microprocessor-controlled turbidity bypass sensor ULTRATURB sc for very low to medium turbidities with comprehensive self-diagnostics
Measuring technique	90° infrared pulse scattered light technique in accordance with ISO 7027-1:2016
Measuring range	0.0001–1000 FNU (TE/F, NTU, FTU) can be programmed as required (0.0001–250 EBC = 2500 ppm SiO ₂)
Resolution	0.0001–0.9999 / 1.00–9.99 / 10.0–99.9 / 100–1000 FNU
Precision	±0.008 FNU or ±1 % of the measured value (0–10 FNU)
Reproducibility	±0.003 FNU or ±0.5 % of the measured value (0–2 FNU)
Response time	1–60 s (can be programmed as required)
Air bubble compensation	Physical-mathematical
Calibration	Permanently set at the factory (Validation using formazine, StablCal)
Sample flow rate	Min. 0.2 L/min, max. 1 L/min, max. 6 bar (at 20 °C (at 68 °F))
Sample temperature	Max. 50 °C (Max. 122 °F)
Salt content of the probe	Tested to 65 g/L (maximum)
Ambient temperature	+2 °C to +40 °C (+ 36 °F to +104 °F)
Sample connection	Tubing (ID 13 mm) or fixed connection (PVC system component pipework)
Automatic cleaning of the measuring chamber	Automatic wiper cleaning, time controlled and as necessary
Materials	Measuring window: quartz
	Measuring chamber: Noryl GFN2
	Wiper axle: stainless steel 1.4571
	Wiperarm: titanium alloy
	Wiper profile: silicone
Housing	Enclosure rating: IP55 Plastic housing ASA
Inspection interval	Two years (minimum)
Dimensions	(W × H × D) 250 × 240 × 110 mm
Mass	Approx. 1.5 kg
User maintenance	0.5 h each month, typical
Certification	CE
Warranty	1 year (EU: 2 years)

1.1 Dimensions

Fig. 1 ULTRATURB sc dimensions

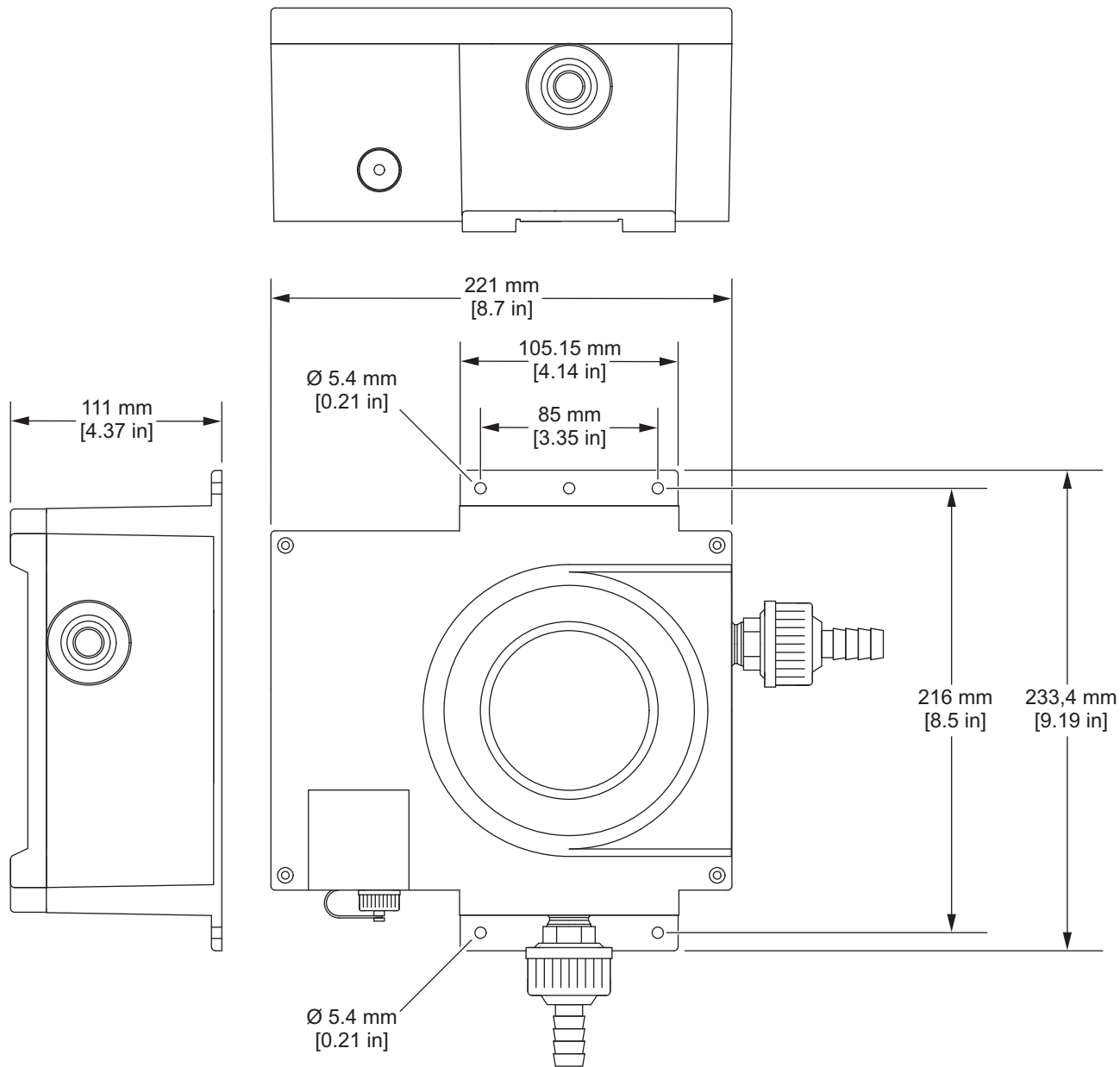

In no event will the manufacturer be liable for damages resulting from any improper use of product or failure to comply with the instructions in the manual. The manufacturer reserves the right to make changes in this manual and the products it describes at any time, without notice or obligation. Revised editions are found on the manufacturer's website.

2.1 Safety information

The manufacturer is not responsible for any damages due to misapplication or misuse of this product including, without limitation, direct, incidental and consequential damages, and disclaims such damages to the full extent permitted under applicable law. The user is solely responsible to identify critical application risks and install appropriate mechanisms to protect processes during a possible equipment malfunction.

Please read this entire manual before unpacking, setting up or operating this equipment. Pay attention to all danger and caution statements. Failure to do so could result in serious injury to the operator or damage to the equipment.

Make sure that the protection provided by this equipment is not impaired. Do not use or install this equipment in any manner other than that specified in this manual.

2.1.1 Use of hazard information



DANGER

Indicates a potentially or imminently hazardous situation which, if not avoided, will result in death or serious injury.



WARNING

Indicates a potentially or imminently hazardous situation which, if not avoided, could result in death or serious injury.



CAUTION



Indicates a potentially hazardous situation that may result in minor or moderate injury.

NOTICE

Indicates a situation which, if not avoided, may cause damage to the instrument. Information that requires special emphasis.

2.1.2 Precautionary labels

Read all labels and tags attached to the instrument. Personal injury or damage to the instrument could occur if not observed. A symbol on the instrument is referenced in the manual with a precautionary statement.

	This is the safety alert symbol. Obey all safety messages that follow this symbol to avoid potential injury. If on the instrument, refer to the instruction manual for operation or safety information.
	Electrical equipment marked with this symbol may not be disposed of in European domestic or public disposal systems. Return old or end-of-life equipment to the manufacturer for disposal at no charge to the user.
	This symbol indicates that a risk of electrical shock and/or electrocution exists.

2.2 Applications

ULTRATURB sc bypass sensors are innovative precision turbidity measuring instruments developed using the latest technical findings.

ULTRATURB sc bypass sensors are developed for waste and drinking water applications. The very robust *seawater* version is developed especially for seawater applications with high salt concentrations (e.g. wash water monitoring of exhaust gas cleaning systems (EGCS) and drinking water abstraction from seawater, fish farming or seawater aquariums).

Turbidities in the range of FNU (NTU) 0.0001–1000 are measured and displayed alphanumerically using a controller. This high resolution facilitates precision differentiation, even for ultra clear liquids.

A pulsed, long-life IR radiation source (LED) ensures that costs are minimised.

ULTRATURB sc turbidity sensors are designed in accordance with ISO 7027-1:2016 and are permanently calibrated before leaving the factory. All key data is set to practical standard values.

The instruments are immediately ready for use after connection to the power supply and the supply of sample water. The measuring range and all data outputs are modified to suit requirements using menus on the controller.

All optical and electronic assemblies are installed in housings that are physically very strong and proof against water jets.

The measuring chambers of the ULTRATURB sc also have automatic wiper cleaning that reliably prevents soiling of the optical systems as it starts to build up and significantly reduces the user maintenance. Cleaning is performed at an interval set to suit local requirements. The cleaning intervals are adjusted to suit the expected level of soiling during commissioning. The user can straightforwardly change the interval at a later date. The number of cleaning operations already performed can be checked on the SENSOR SETUP menu using the COUNTER command.

2.3 Measuring principle

The nephelometric scattered light technique is a method for the determination of the very low to medium turbidities in liquids that is comparable worldwide.

Using this method, the light scattered sideways by the turbidity particles is measured over an angle of 90°. The low acquisition limit for this method makes it possible to even reliably differentiate turbidity particles in distilled water. This technique is defined in ISO 7027-1:2016. ULTRATURB sc sensors are designed in accordance with the requirements in this standard.

2.4 Handling

The sensor contains high-quality optical and electronic assemblies. For this reason attention is to be paid to ensuring that the sensor is not subjected to any hard mechanical knocks. There are no components that can be maintained by the user inside the sensor – except the manual cleaning of the measuring chamber and the replacement of the wiper profiles and the desiccant.

2.5 Items supplied

- ULTRATURB sc sensor
- Connecting cable (length as per order)
- User Manual
- Factory test certificate
- Accessory set LZP816
- Wiper set (for 4 changes) LZV275

2.6 Function check

After unpacking, all components should be checked for any transport damage and a short function check performed prior to installation.

For this purpose the sensor is connected to the controller and the controller is plugged into the mains. Shortly after the controller is plugged in, the controller is activated and the instrument switches to the display of measurements. Here the measured value taken in air is meaningless.

Note: *It is only possible to check the operative zero point using very high purity water!*

If no messages appear on the controller, the function check is then complete.

**DANGER**

Installation may only be carried out by qualified experts in accordance with all local safety regulations.

3.1 Assembling

Select an appropriate installation location for the instrument to guarantee

- safe installation
- safe operation
- problem-free maintenance

Plan how to lay cables and hoses and their path in advance. Lay the hoses, data cables and power cables without any bends. Only original replacement and accessory parts recommended by the manufacturer may be used.

Make sure the mount has a sufficient bearing capacity. The dowels must be selected and authorized according to the condition of the wall. The manufacturer shall accept no liability if the instrument is installed incorrectly.

Install the instrument in a horizontal position.

Fig. 2 Assembling

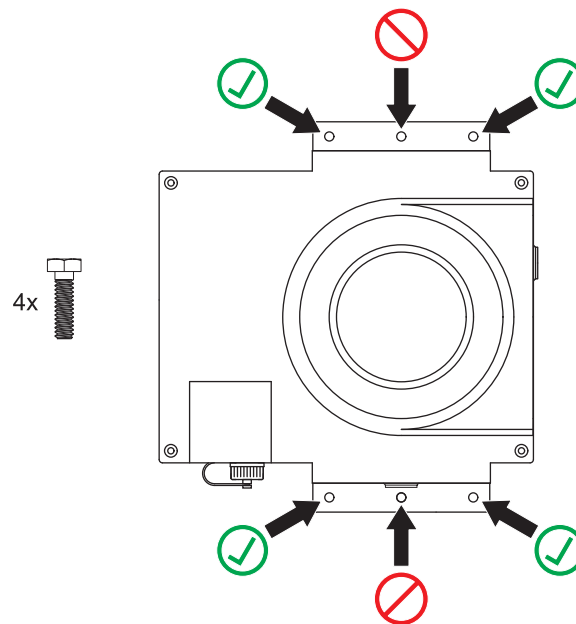

3.1.1 Connectors

Important Note: The instrument can be damaged if the connectors and/or the union nuts are attached too tightly. Only hand-tighten the union nuts for the hose mounts. If necessary, hold the connectors with a tool (SW 22).

The measuring instrument can be integrated into the measurement and analysis process using tubing (ID 13 mm) or a fixed connection (PVC system component pipework, compatible with 1" union nut).

Table 1: Connectors

External thread	Pipe thread in accordance with DIN ISO 228
large	G1A
small	G½A

3.1.1.1 Selection of diaphragm plate

With samples that tend to emit gases, bubbles may form in the measuring chamber. This causes extremely strongly fluctuating measurement values. In the event of strongly fluctuating measurement values, replace the diaphragm plate in the drain connector.

Note: Observe the flow quantity and flow direction of the sample provided in the technical data.

Table 2: Preselect the diaphragm plate

Flow quantity/pressure	Diaphragm plate
large	large hole
medium	medium hole
small	small hole

3.2 Instrument layout

Fig. 3 Instrument layout ULTRATURB sc

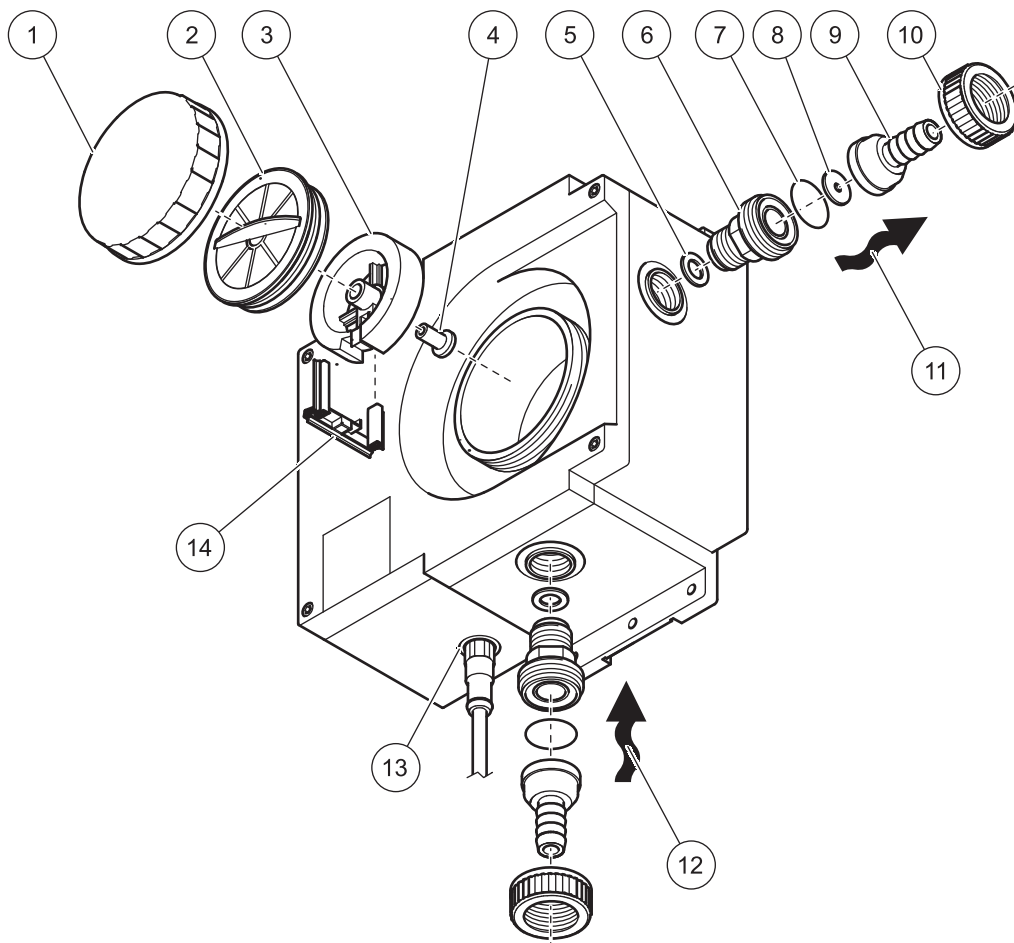

1. Screw top	8. Diaphragm plate* (if necessary), LZP600 1.2 mm 2 mm 3 mm
2. Measuring chamber sealing plug	9. Tubing nipple* (Ø 13 mm)
3. Clutch wheel, LZV842	10. Union nut* 1"
4. Plug socket	11. Drain
5. Sealing ring (pre-assembled)	12. Feed
6. Union (pre-assembled)	13. Sensor cable socket
7. O-ring*	14. Wiper holder, LZV842

* Included in the accessory set (connection) LZP816

3.3 Connecting sensor cable



CAUTION

Always lay cables and hoses so that they do not pose a tripping risk.

1. Unscrew the protective caps from the controller socket and the cable plug and retain them.
2. Pay attention to the guide in the plug and slide the plug into the socket.
3. Tighten the nut by hand.

Note: *Extension cables are available in various lengths (refer to [Section 7, Replacement parts and accessories, page 29](#)).
Maximum cable length 100 m (328 ft).*

Fig. 4 Connection of the sensor plug to the controller

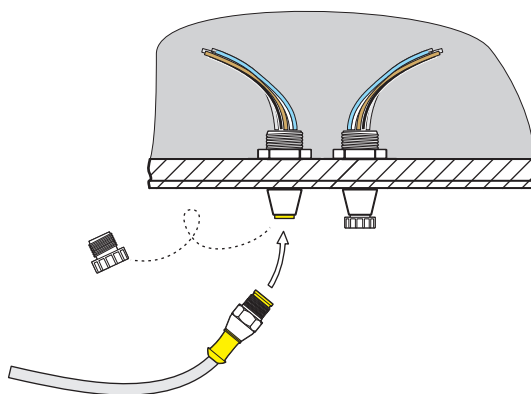
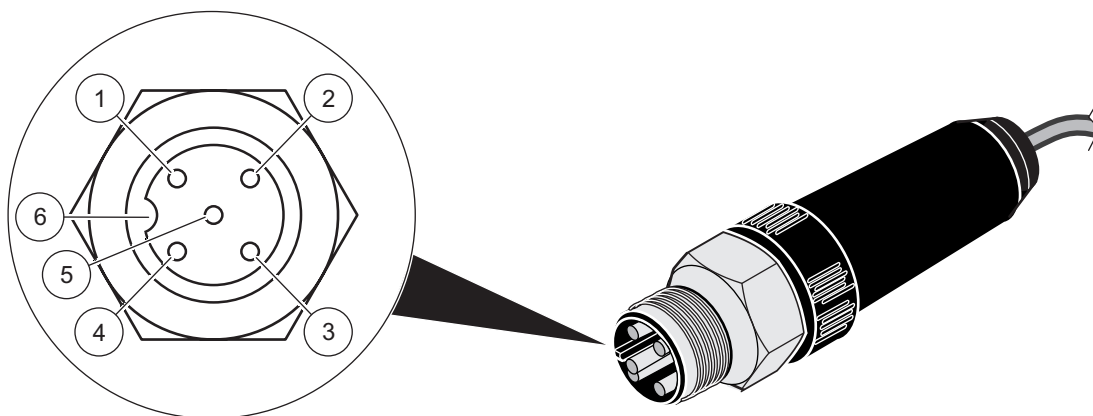

Fig. 5 Sensor connector pin assignment



Number	Description	Cable colour
1	+12 VDC	brown
2	Ground	black
3	Data (+)	blue
4	Data (-)	white
5	Screen	Screen (grey)
6	Notch	-

4.1 Operating the sc controller

The sensor can be operated with all sc controllers. Prior to using the sensor, familiarise yourself with the principle of operation of your controller. Learn how to navigate in the menus and run appropriate functions.

4.2 Sensor setup

When you connect the sensor for the first time, the serial number of the sensor is displayed as the sensor name. You can change the sensor name as follows:

1. Open the MAIN MENU.
2. Choose SENSOR SETUP and accept.
3. Choose the related sensor and accept.
4. Choose CONFIGURE and accept.
5. Choose EDITED NAME and accept.
6. Edit the name and accept to return to the SENSOR SETUP menu.

In the same way complete your system configuration using the following commands:

- MEAS UNITS
- CLEAN. INTERVAL
- RESPONSE TIME
- LOGGER INTERVAL
- RESOLUTION
- SET DEFAULTS

4.3 Sensor data logger

A data memory and event memory per sensor are available via the sc controller. While measured data are saved in the data memory at stipulated intervals, the event memory collects numerous events such as configuration changes, alarms and warning conditions. Both the data memory and the event memory can be read out in CSV format. For information on how you can download the data, please see the controller manual.

4.4 Menu structure

4.4.1 SENSOR DIAG

ERROR LIST
Possible error messages: WIPER POS, LED C., GAIN TOO HIGH
WARNING LIST
Possible warnings: PROFILE COUNTER, MOIST, USER CAL INTERVAL

Note: In [Section 6, page 27](#) you will find, along with a list of all error messages and warnings, also a description of all the actions necessary.

Operation

4.4.2 SENSOR SETUP

WIPE			<i>Initiates a wiping action</i>
VERIFY		Verification	
CALIBRATE			
STANDARD	Selection as per CAL. CONFIG OUTPUT MODE	Calibration with standard solution	<i>Procedure during calibration, menu based</i>
OFFSET	Selection as per CAL. CONFIG OUTPUT MODE	Zero point setting	<i>Zero point setting, menu based</i>
CAL. FAKTORS	FAC. STANDARD		<i>0.50 to 2.00</i>
	OFFSET		<i>-0.100 to +0.100 TRBFNU</i>
CAL. CONFIG	OUTPUT MODE	HOLD ACTIVE TRANSFER CHOICE	<i>Behaviour of the outputs during calibration or zero point setting</i>
	CAL. INTERVAL		<i>Adjustable from 0 to 365 days</i>
SET CAL DEFLT			Reset to the default calibration
CONFIGURE			
EDITED NAME		SET DEFAULTS Instrument number	<i>Up to 16-character name possible</i>
MEAS UNITS	mg/L, FNU, NTU, TE/F, EBC	SET DEFAULTS FNU	
CLEAN. INTERVAL		SET DEFAULTS 12 h	<i>10 min, 20 min, 30 min, 2 h, 6 h, 12 h or one time each day at 10:00 am</i>
RESPONSE TIME		SET DEFAULTS 15 s	<i>0 to 60 s</i>
LOGGER INTERVAL		SET DEFAULTS 10 min	<i>1-30 min</i>
RESOLUTION		SET DEFAULTS 0.xxx	<i>0.xxx or 0.xxxx (<1 FNU)</i>
SET DEFAULTS	Confirmation prompt		<i>Reset to default configuration for all menu commands listed above.</i>

TEST/MAINT				
PROBE INFO	ULTRATURBsc	Instrument name		
	EDITED NAME			
	SERIAL NUMBER			
	RANGE	0.001 ... 1000 FNU		
	MODEL NUMBER	Item no. sensor		
	SOFTWARE VERS	Sensor software		
	DRIVER VERS			
CAL. DATA	CAL. DATE	Date of the last calibration		
	FACTOR	Default setting 1.00		
	OFFSET	Default setting 0.000 TRBFNU		
COUNTER	TOTAL TIME			
	PROFILE			
	MOTOR			
MAINT. PROC.	CLN. MEAS CHAMB	OUTPUT MODE information	<i>Procedure during cleaning</i>	
	REPLACE PROFILE	OUTPUT MODE information	<i>Procedure during wiper change</i>	
	WIPE	RESOLUTION	<i>Initiates a wiping action</i>	
	SIGNALS	AVER.:		<i>Average value</i>
		S. VAL.:		<i>Individual measured value</i>
		M:		<i>Measured level</i>
		R:		<i>Reference level</i>
		Q:		<i>Quotient M/R</i>
		MOIST		<i>Relative humidity in %</i>
OUTPUT MODE	ACTIVE HOLD TRANSFER CHOICE		<i>Behaviour of the instrument outputs in the MAINT. PROC. menu</i>	

4.5 Calibration with standard solution

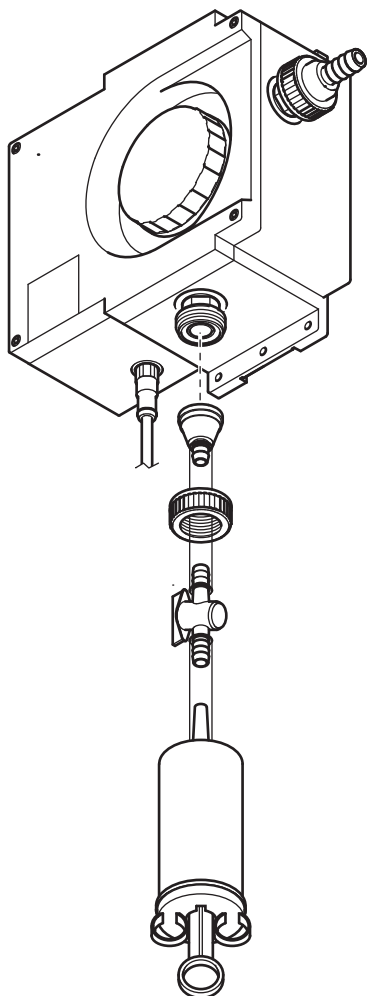

1. Open the MAIN MENU.
2. Choose SENSOR SETUP and accept.
3. Choose the related sensor and accept.
4. Choose CALIBRATE and accept.
5. Choose STANDARD and accept.
6. Shut-off the feed and accept TURN OFF SAMPLE INLET.
7. Drain the measuring chamber using the lower feed union. Accept DRAIN MEAS. CHAMBER.
8. Connect the calibration syringe to the feed union (see Figure) and add the calibration standard. Accept POUR STD INTO MEAS. CHAMBER.
9. Accept PRESS ENTER WHEN STABLE x.xxx TRBFNU.
10. Enter the concentration of the standard solution. Accept CALIBRATE (x.xxx TRBFNU).
11. Remove the calibration syringe and accept REMOVE CALIBRATION SYRINGE.
12. Re-connect the feed and accept CONNECT SAMPLE INLET.
13. Open the feed and accept CAL READY OPEN INLET.
14. Accept OUTPUT ACTIVE.

4.6 Verify using verification standard

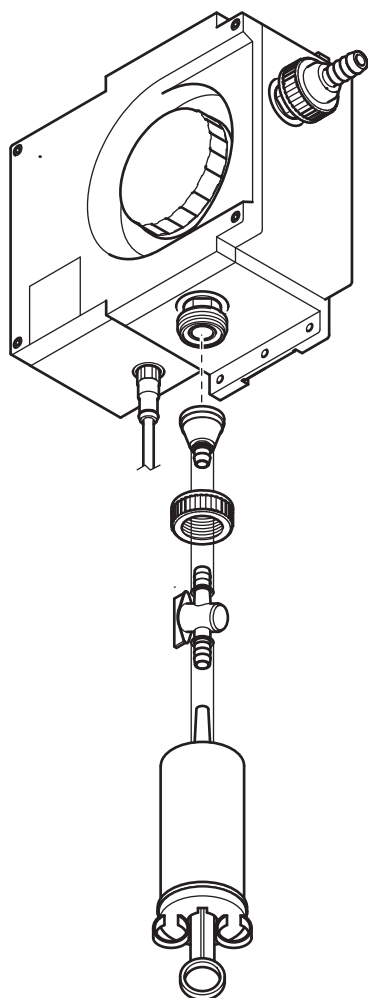

1. Open the MAIN MENU.
2. Choose SENSOR SETUP and accept.
3. Choose the related sensor and accept.
4. Choose VERIFY and accept.
5. Choose OUTPUTS ON HOLD and accept.
6. Shut-off the sample flow and accept TURN OFF SAMPLE INLET.
7. Drain the measuring chamber using the lower feed union. Accept DRAIN MEAS. CHAMBER.
8. Connect the verification syringe to the feed union (see Figure) and add the verification standard. Accept POUR STD INTO MEAS. CHAMBER.
9. Accept PRESS ENTER WHEN STABLE x.xxx TRBFNU.
10. Note the concentration of the verification standard solution. Press ENTER.
11. Remove the verification syringe and accept DRAIN MEAS.CHAMBER.
12. Reconnect the feed and accept CONNECT SAMPLE INLET.
13. Open the feed and accept READY OPEN INLET.
14. Accept OUTPUT ACTIVE.

4.7 Zero point setting

1. Open the MAIN MENU.
2. Choose SENSOR SETUP and accept.
3. Choose the related sensor and accept.
4. Choose CALIBRATE and accept.
5. Choose OFFSET and accept.
6. Shut off the feed and drain the measuring chamber. Connect a membrane filter (LZV325) to the measuring chamber feed. Open the feed and accept POUR 0 STD INTO MEAS. CHAMBER.
7. Accept PRESS ENTER WHEN STABLE x.xxx TRBFNU.
8. Set the zero point and accept CALIBRATE (x.xxx TRBFNU).
9. Accept CAL READY OUTPUT ACTIVE.

It has been possible to reduce the scope of the maintenance to be performed by the user to only a few actions. Clearly summarised in a table and described in detail in the following sections, these actions can be quickly and straightforwardly performed by qualified personnel.

5.1 Maintenance schedule

Maintenance task	Interval
Clean measuring chamber:	Dependent on the substances contained in the water
Replace wiper profile	After 1200 cycles (approximately 18 months at default settings)
Replace desiccant	Every 2 years
Check zero point	Dependent on the substances contained in the water
Check gradient	One time a year (minimum) or as necessary Note: For maritime applications, including exhaust gas cleaning systems (EGCS), one time every two years (minimum).

5.2 Cleaning measuring chamber

The cleanliness of the measuring chamber is crucial for correct measured results. This cylindrical optical measuring chamber has a rotating wiper with three wiper profiles; these prevent normal soiling of the optical system as it starts to build up. With very stubborn deposits, manual cleaning with a suitable cleaning agent (e.g. citric acid) is recommended.



CAUTION

Observe safety regulations and wear safety clothing!

- Safety glasses
 - Gloves
 - Overalls
1. Open the MAIN MENU.
 2. Choose SENSOR SETUP and accept.
 3. Choose the related sensor and accept.
 4. Choose TEST/MAINT and accept.
 5. Choose MAINT. PROC and accept.
 6. Choose CLN. MEAS CHAMB and accept.
 7. Shut-off the feed and accept TURN OFF SAMPLE INLET.
 8. Drain the measuring chamber via the lower feed union and accept DRAIN MEAS. CHAMBER.

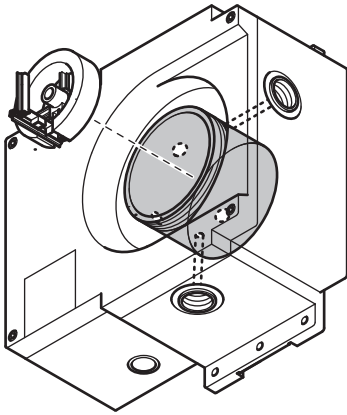

9. Remove the screw top and the sealing plug for the measuring chamber and accept OPEN MEAS. CHAMBER.
10. Remove the wiper holder and accept REMOVE WIPER HOLDER.
11. Clean the measuring chamber and accept CLN. MEAS CHAMB.
12. Re-fit the wiper holder and accept REPLACE WIPER HOLDER.
13. Seal the measuring chamber again with sealing plug and screw top and accept CLOSE MEAS. CHAMBER.
14. Open the sample feed and accept TURN OFF SAMPLE INLET.
An automatic wipe is performed.

5.3 Replacing wiper profiles

The life of the wiper profiles is, on the one hand, dependent on the number of cleaning actions performed, and on the other hand is also dependent on the type of deposits to be removed. Thus the life of the wiper profiles varies from case to case.

The wiper profiles supplied with the instrument are sufficient to the cover requirements for an average year.

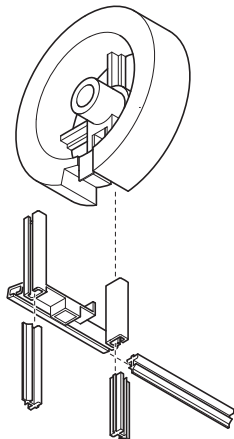
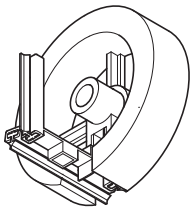

1. Open the MAIN MENU.
2. Choose SENSOR SETUP and accept.
3. Choose the related sensor and accept.
4. Choose TEST/MAINT and accept.
5. Choose MAINT. PROC and accept.
6. Choose REPLACE PROFILE and accept.
7. Shut-off the feed and accept TURN OFF SAMPLE INLET.
8. Drain the measuring chamber via the lower feed union and accept DRAIN MEAS. CHAMBER.
9. Remove the screw top and the sealing plug for the measuring chamber and accept OPEN MEAS. CHAMBER.
10. Remove the wiper holder and accept REMOVE WIPER HOLDER.
11. Clean the measuring chamber and accept CLN. MEAS CHAMB.
12. Renew the wiper profiles and accept REPLACE PROFILE.
13. Re-fit the wiper holder and accept REPLACE WIPER HOLDER.
14. Seal the measuring chamber again with sealing plug and screw top and accept CLOSE MEAS. CHAMBER.
15. Open the sample feed and accept TURN OFF SAMPLE INLET.
An automatic wipe is performed.

5.4 Replacing desiccant

The ULTRATURB sc turbidity sensor is continuously subject to a wet environment. To provide protection against the moisture, there are 2 generously sized desiccant bags close to the optical and electronic components. To maintain this protection, the manufacturer recommends replacement or regeneration every 2 years.

To replace the desiccant, open the housing and replace the two desiccant bags, 4 units (refer to [Figure 6](#), item 1) and 0.5 units (refer to [Figure 6](#), item 2) as per the figure.

Figure 6 Replacing desiccant

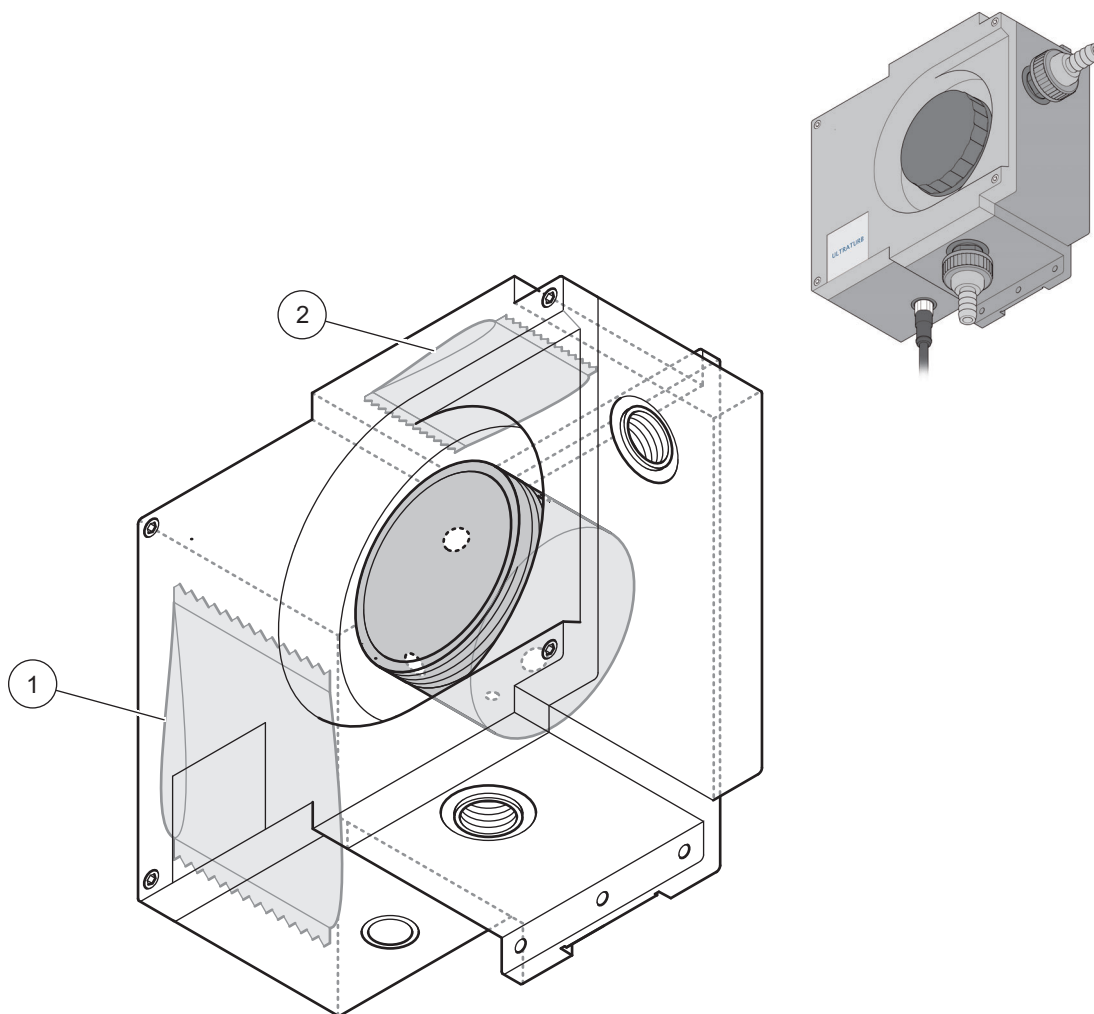

1. Desiccant bag with 4 units, LZ304

2. Desiccant bag with 0.5 units, LZ303

5.5 Monitoring test equipment

As part of a quality assurance system for test equipment monitoring, it is necessary to check the instrument calibration; this can be performed using a formazine standard series in accordance with ISO 7027-1:2016.

You can either make up the formazine solution yourself as per the instructions that follow [5.5.1 Preparing formazine solution in accordance with ISO 7027-1:2016](#) or procure it from the manufacturer (LCW 813 or Stabl Cal).

1. To check the instrument calibration, first thoroughly rinse out the measuring chamber using distilled water.
2. Prepare a turbidity series using formazine reference solutions as per ISO 7027-1:2016; the measuring series should correspond to the measuring range selected. For example, in the measuring range FNU 0–5.0 chose reference solutions with FNU 0.5–1.0–2.0–3.0–4.0.

Note: *If there are any variations in the measurements, it is recommendable to measure a new standard preparation prior to changing the instrument calibration! Experience has shown that the variation in the formazine preparation can be greater than the possible drift in the ULTRATURB instrument.*

When checking the instruments as per EN 450901 or GLP we therefore recommend recording the date in an instrument log and checking for any long-term drift. Checks on the operation of the ULTRATURB can in practice also be made by means of parallel measurements with turbidity photometers designed in accordance with DIN and ISO.

5.5.1 Preparing formazine solution in accordance with ISO 7027-1:2016

Chemicals

Chemicals of "analysis" purity are used. The chemicals must be stored in hard glass bottles.

Water

- Place a membrane filter, pore size 0.1 µm (for bacteriological experiments), for 1 hour in 100 mL of distilled water.
- Filter 250 mL water through this filter and discard the water.
- Then filter 500 mL of distilled water twice through the same filter and use this water for making up the standard solution.

Formazine (C₂H₄N₂) parent solution

CAUTION

Hydrazine sulphate is toxic and possibly carcinogenic



- Dissolve 10.0 g of hexamethylenetetramine (C₆H₁₂N₄) in water and top up to 100 mL (solution A).
- Dissolve 1 g of hydrazine sulphate (N₂H₆SO₄) in water and top up to 100 mL (solution B).
- Mix 5 mL of solution A with 5 mL of solution B.
- After 24 hours at 25° C (±3 °C) (77 °F (± 5.4 °F)) top up this solution with water to 100 mL.

The turbidity of this parent solution is 400, stated in Formazine Attenuation Units (FAU) or Formazine Nephelometric Units (FNU). This solution can be stored in a dark place at 25 °C (± 3 °C) (77 °F (± 5.4 °F)) for around 4 weeks.

Formazine reference solution

Dilute the parent solution with the aid of pipettes and measuring flasks to produce reference solutions in the required range. These solutions can only be stored for a very limited period.

6.1 Error messages

Possible sensor errors are displayed by the controller.

Table 3: Error messages

Error displayed	Cause	Rectification
NONE	Correct operation	
WIPER POS.	Wiper not is correct starting position	Initiate wiper function, call service
LED C.	LED faulty	Call service
GAIN TOO HIGH	Incorrect adjustment Incorrect calibration standard Measuring chamber soiled LED faulty	Clean measuring chamber, perform calibration, call service

6.2 Warnings

Possible warning messages are displayed by the controller.

Table 4: Warnings

Error displayed	Cause	Rectification
NONE	Correct operation	
PROFILE COUNTER	Counter elapsed	Change wiper profiles
MOIST	Moisture > 10 % relative humidity	Replace desiccant
CAL. INTERVAL	Counter elapsed	Perform calibration

7.1 Sensor options

Description	Cat. no.
ULTRATURB <i>seawater</i> sc turbidity bypass sensor without cable	LPV415.99.02001
ULTRATURB <i>seawater</i> sc turbidity bypass sensor with 0.35 m (1.1 ft.) cable	LPV415.99.12001
ULTRATURB <i>seawater</i> sc turbidity bypass sensor with 1 m (3.3 ft.) cable	LPV415.99.82001
ULTRATURB <i>seawater</i> sc turbidity bypass sensor with 5 m (16.40 ft.) cable	LPV415.99.22001
ULTRATURB <i>seawater</i> sc turbidity bypass sensor with 10 m (32.81 ft.) cable	LPV415.99.32001

7.2 Replacement parts

Description	Cat. no.
Set of wiper profiles (for 4 changes)	LZV275
Wiper holder, ULTRATURB <i>seawater</i> sc	LZV842
Desiccant bag 0.5 U	LZX303
Desiccant bag 4 U	LZX304
Accessory set (connection)	LZP816

7.3 Accessories

Description	Cat. no.
Extension cable 0.35 m (1.15 ft.)	LZX847
Extension cable 1 m (3.3 ft.)	6122400
Extension cable 5 m (16.40 ft.)	LZX848
Extension cable 10 m (32.81 ft.)	LZX849
Extension cable 15 m (49.21 ft.)	LZX850
Extension cable 20 m (65.62 ft.)	LZX851
Extension cable 30 m (98.43 ft.)	LZX852
Formazine turbidity standard	LCW813
Turbidity calibration set for liquid standard	LZV451
Set of filters for zero point calibration (0.2 mm membrane filter incl. connecting material)	LZV325

HACH COMPANY World Headquarters
P.O. Box 389, Loveland, CO 80539-0389 U.S.A.
Tel. (970) 669-3050
(800) 227-4224 (U.S.A. only)
Fax (970) 669-2932
orders@hach.com
www.hach.com

HACH LANGE GMBH
Willstätterstraße 11
D-40549 Düsseldorf, Germany
Tel. +49 (0) 2 11 52 88-320
Fax +49 (0) 2 11 52 88-210
info-de@hach.com
www.de.hach.com

HACH LANGE Sàrl
6, route de Compois
1222 Vérenaz
SWITZERLAND
Tel. +41 22 594 6400
Fax +41 22 594 6499

