

NOTES:
1. ALL DIMENSIONS ARE IN INCHES [MILLIMETERS].

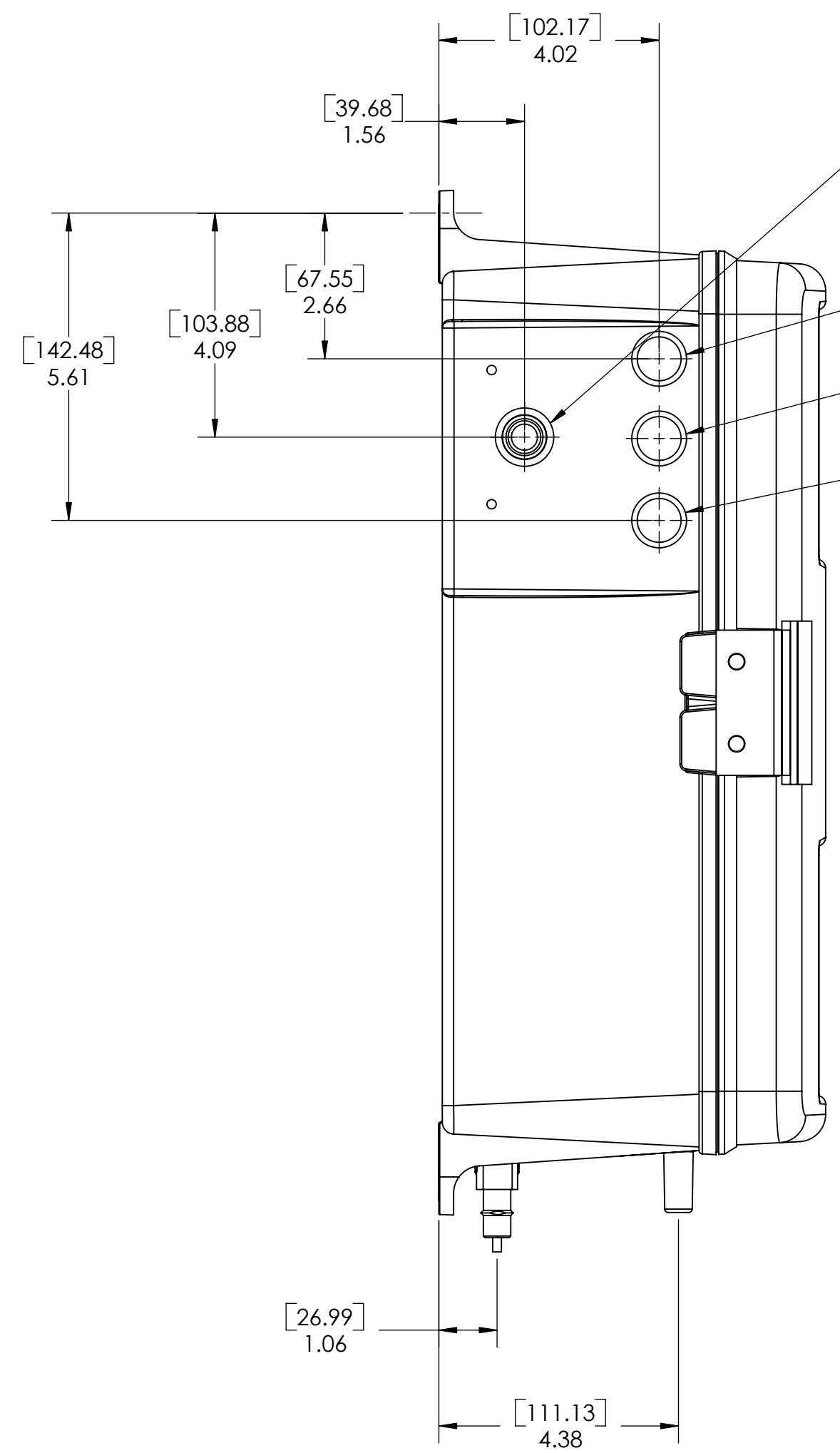

AIR PURGE QUICK CONNECT
.25 O.D POLYETHYLENE TUBING
(CAT. NO. 4743800)

RELAY/ALARM
CONTACT
CONNECTIONS

NETWORK AND
4-20 mA
CONNECTIONS

POWER
CONNECTIONS

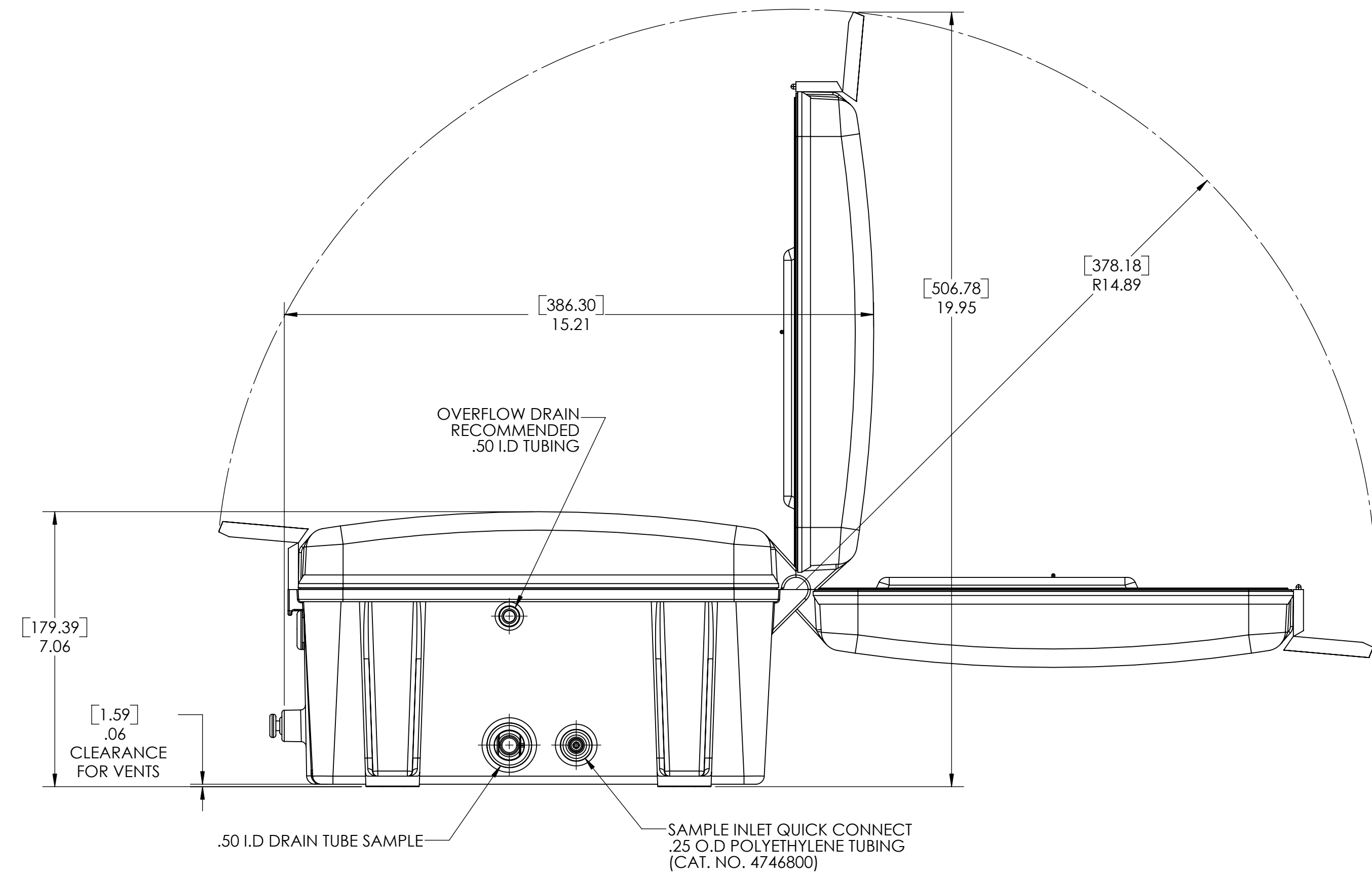
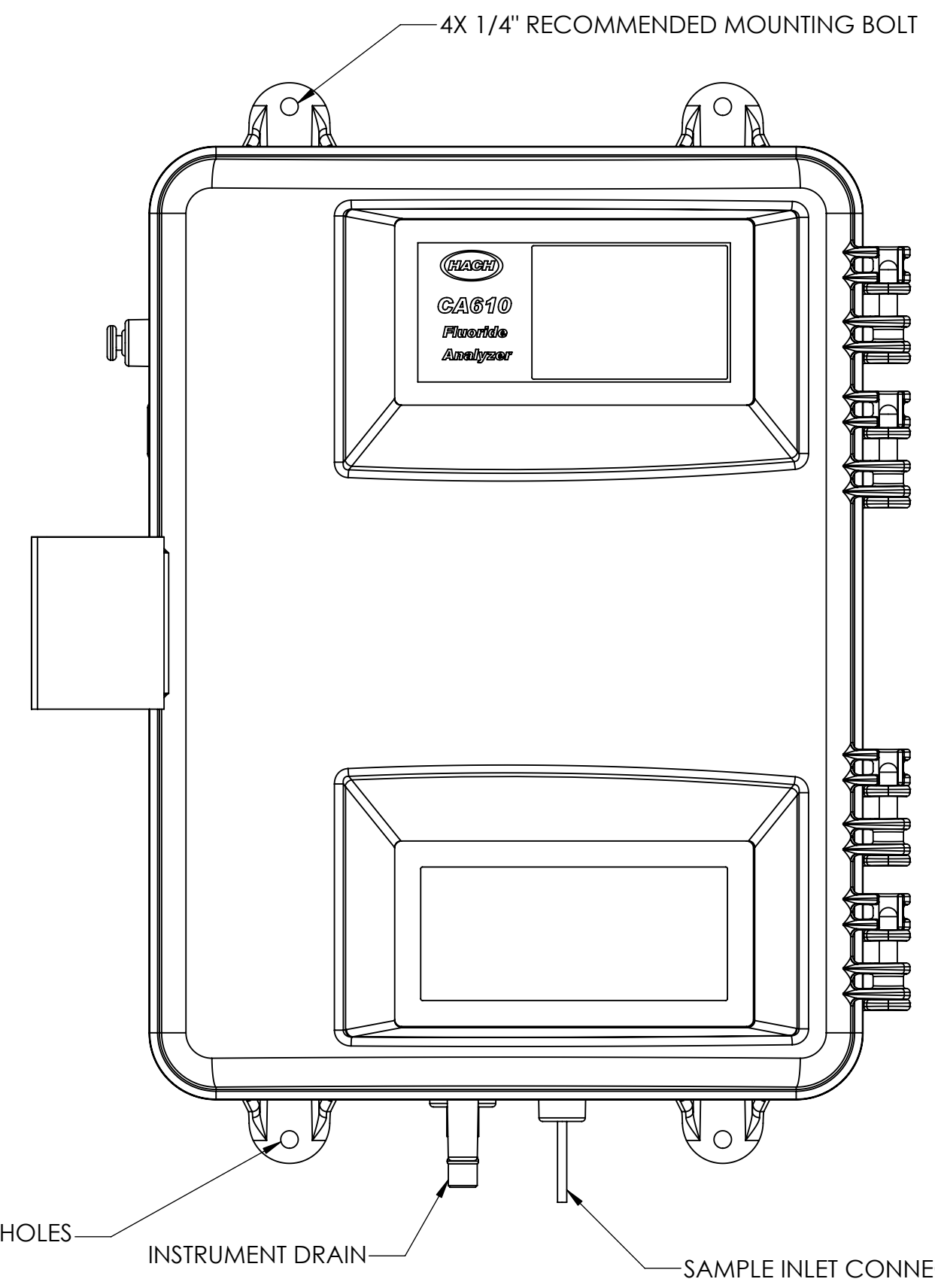

INSTRUMENT DIMENSIONS

REVISION		
REV	DESCRIPTION	APPROVED
A	PRODUCTION RELEASE	

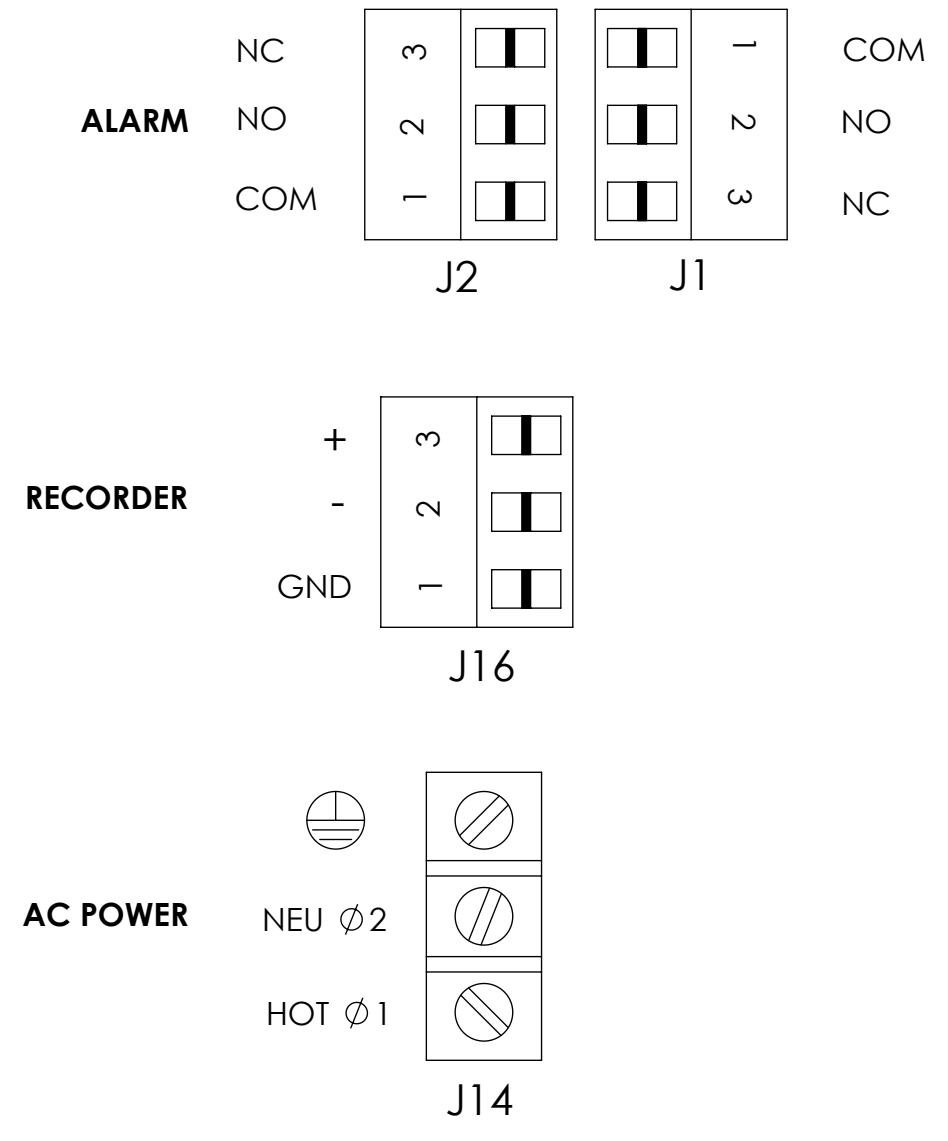

CUSTOMER POWER CONNECTIONS TO ANALYZER
POWER: 100-115 / 230 Vac, 50/60 Hz, 95 VA (FUSED AT 2.50A)

GENERAL INFORMATION:

- ENCLOSURE: IP62 - RATED WITH THE GASKETED DOOR LATCHED.
- INSTRUMENT SHIPPING WEIGHT: 11.3 Kg (25 lb).
- INLET PRESSURE TO INSTRUMENT: 1 TO 10 psig.
- SAMPLE FLOW RATE TO SAMPLE CONDITIONING: 200 TO 500 mL/min.

NOTICE-HACH COMPANY CLAIMS PROPRIETARY RIGHTS IN THE INFORMATION DISCLOSED ON THIS DRAWING. IT IS ISSUED IN CONFIDENCE FOR ENGINEERING INFORMATION ONLY AND MAY NOT, IN WHOLE OR IN PART, BE USED TO MANUFACTURE ANYTHING, WHETHER OR NOT SHOWN HEREON, REPRODUCED OR DISCLOSED TO ANYONE WITHOUT DIRECT PERMISSION FROM HACH COMPANY.

MATERIAL	UNLESS OTHERWISE SPECIFIED: DIMENSIONS ARE IN INCHES TOLERANCES: X = ± XX = ± XXX = ± ANGLES = ±	NAME TCS DATE 10/09/04	DATE 10/09/06	<p>HACH COMPANY 5600 LINDBERH DR LOVELAND, CO. 80539</p>
	THIRD ANGLE PROJECTION	<p>INTERPRET GEOMETRIC TOLERANCING PER: ANSI Y14.5M 1994</p>		
<p>DO NOT SCALE THIS SHEET</p>				<p>TITLE: TRANSMITTAL, CA 610</p> <p>SIZE DWG. NO. D 5740087 REV A</p> <p>SCALE: 2:5 WEIGHT: SHEET 1 OF 2</p>

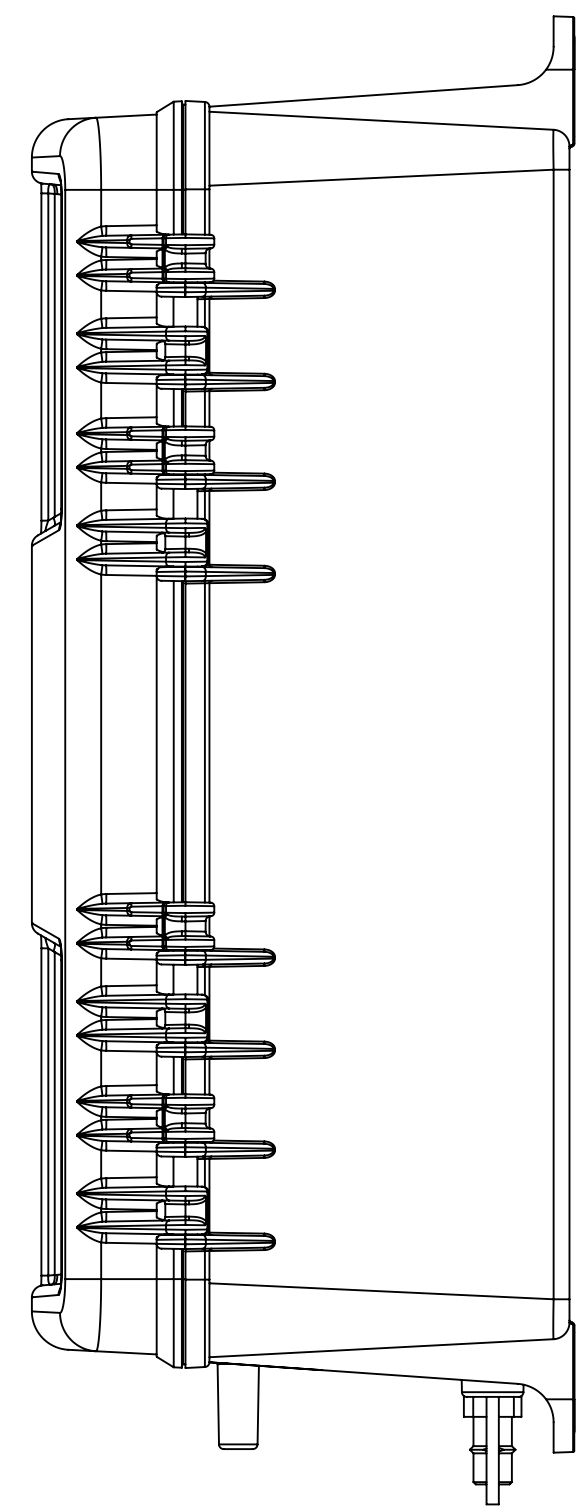

VIEW A-A
HINGE SIDE

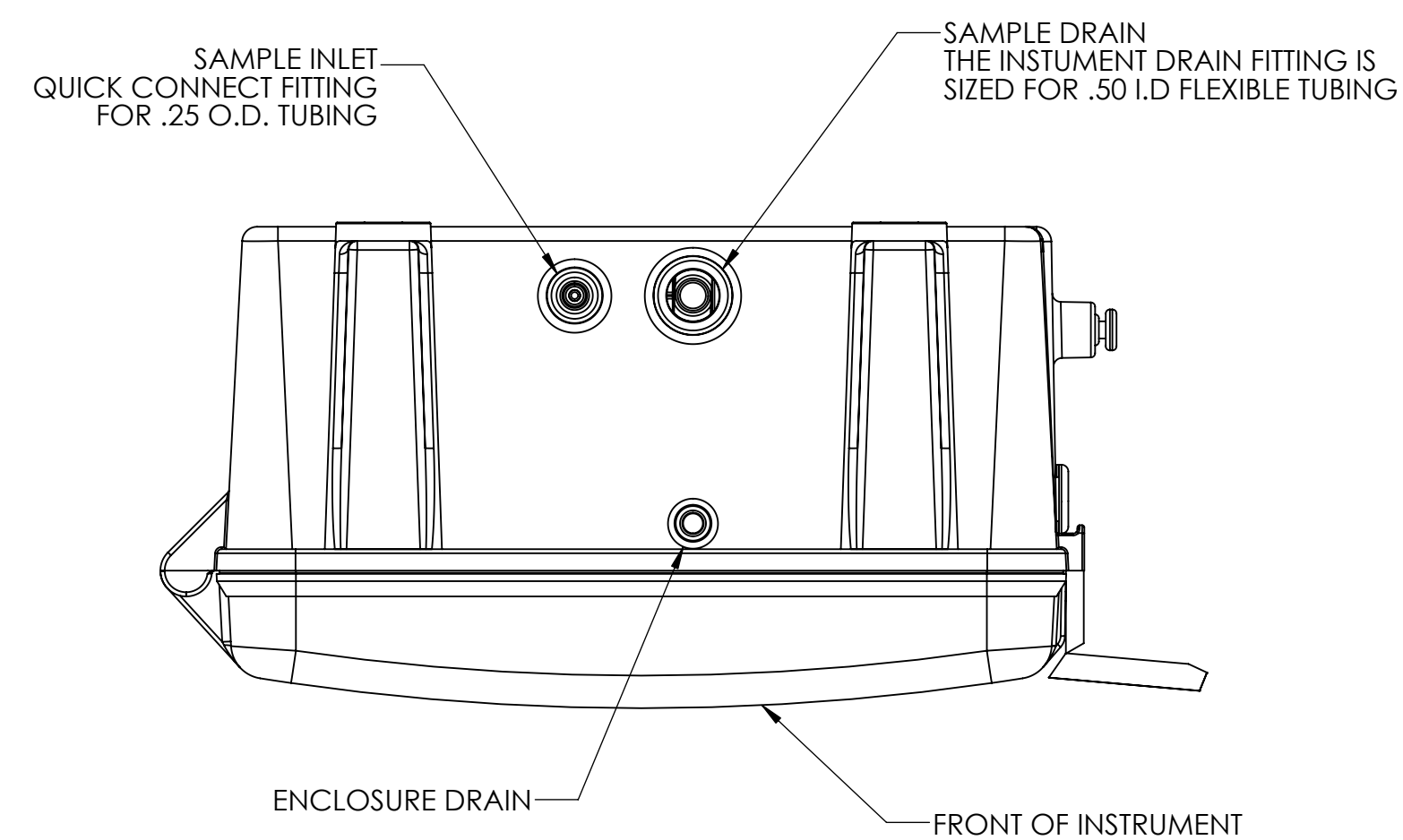
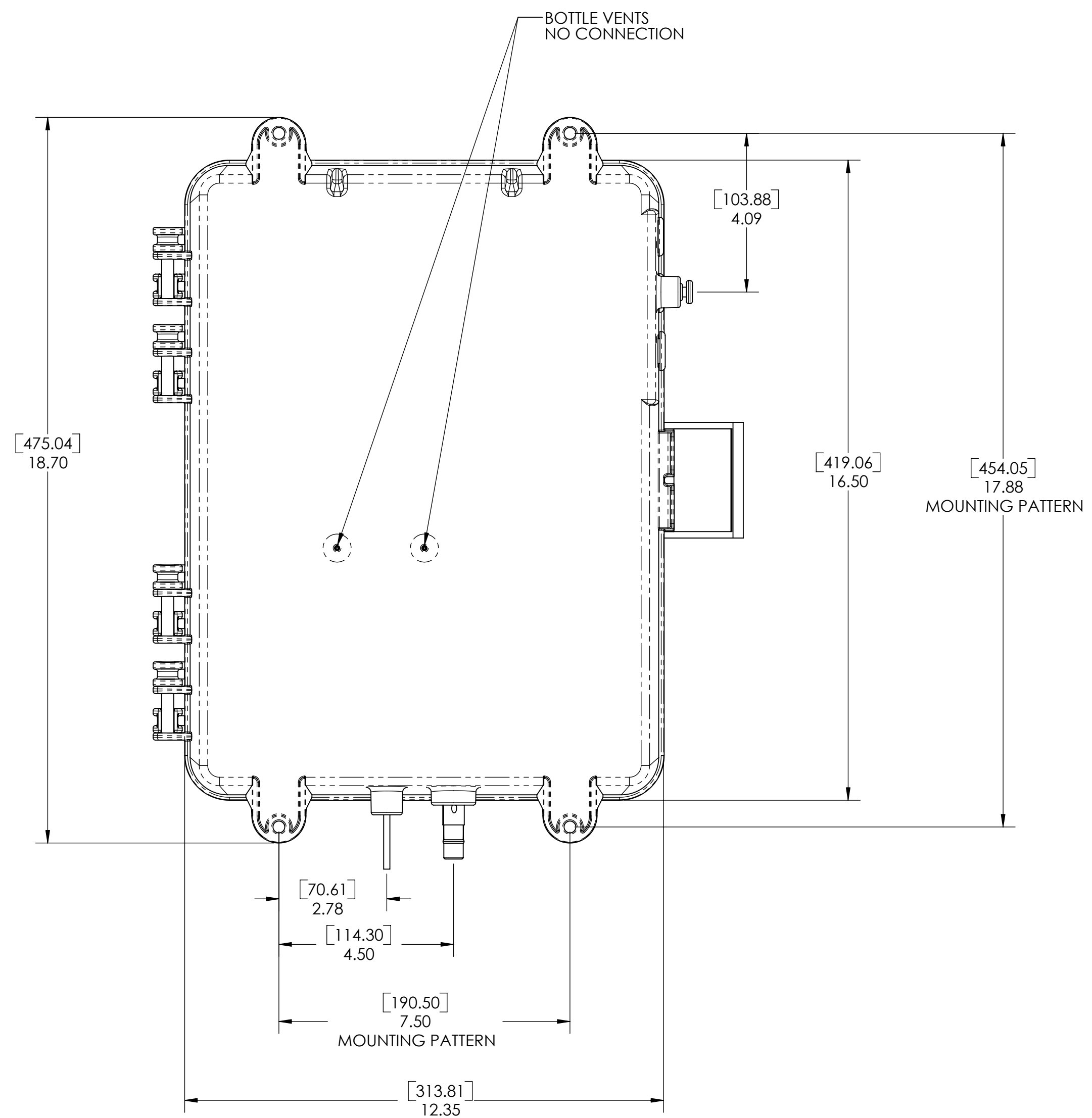

PLUMMING CONNECTIONS