



DOC023.53.90627

PHOSPHAX sc LR, PHOSPHAX indoor sc LR

User Manual

12/2019, Edition 2

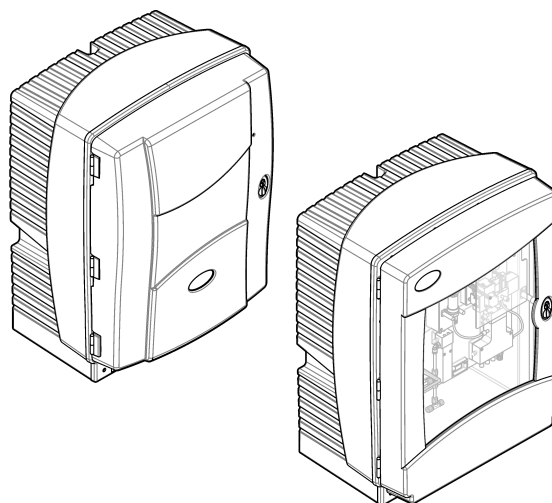

Section 1 Specifications	3
1.1 Sample requirements.....	4
1.2 Interferences.....	4
Section 2 General information	5
2.1 Safety information.....	5
2.1.1 Use of hazard information.....	5
2.1.2 Precautionary labels.....	5
2.1.3 Chemical and biological safety.....	6
2.1.4 Certification.....	6
2.2 Product overview.....	7
2.2.1 Status indicator light.....	9
2.3 Product components.....	9
Section 3 Installation	11
3.1 Installation guidelines.....	11
3.2 Mechanical installation.....	11
3.2.1 Attach the instrument to a wall.....	11
3.2.2 Open the enclosure.....	13
3.2.3 Remove the transport lock.....	14
3.3 Electrical connectors and plumbing access ports.....	15
3.4 Plumbing.....	15
3.4.1 Sample line guidelines.....	15
3.4.2 Drain line guidelines.....	16
3.4.3 Tubing considerations.....	16
3.5 System configuration options.....	16
3.5.1 Plumbing one outdoor analyzer.....	18
3.5.2 Plumbing two outdoor analyzers.....	19
3.5.3 Plumbing one outdoor analyzer with continuous sample feed.....	21
3.5.4 Plumbing two outdoor analyzers with continuous sample feed.....	22
3.5.5 Plumbing one indoor analyzer.....	24
3.5.6 Plumbing two indoor analyzers.....	25
3.5.7 Plumbing one indoor analyzer with continuous sample feed.....	27
3.5.8 Plumbing two indoor analyzers with continuous sample feed.....	27
3.5.9 Two-parameter configuration.....	29
3.6 Install the collecting tray and humidity sensor.....	32
3.7 Install the reagents.....	32
3.8 Electrical installation.....	34
3.8.1 Electrostatic discharge (ESD) considerations.....	34
3.8.2 Connect the optional heated drain.....	34
3.8.3 Supply power to the analyzer.....	35
3.9 Close the analyzer.....	37
Section 4 Operation	39
4.1 User navigation.....	39
4.2 Startup.....	39
4.3 Configure the instrument.....	39
4.4 Configure the calibration settings.....	40
4.5 Show analyzer data.....	40
4.6 Configure the maintenance settings.....	41
4.7 System configuration.....	42
4.8 Do a measurement.....	42
4.9 Do a calibration.....	42
4.10 Do a clean cycle.....	42

Table of Contents

Section 5 Maintenance	45
5.1 Maintenance schedule.....	45
5.2 Examine for damage.....	45
5.3 Examine the tubing and fittings.....	45
5.4 Clean the instrument.....	46
5.5 Clean spills.....	46
5.6 Replace the reagents.....	46
5.7 Replace the air filter pads.....	46
5.8 Replace the pump head for air pump (piston pump).....	48
5.9 Do a leakage test.....	49
5.10 Replace the fuses.....	50
5.11 Do a validation check (analytical quality assurance).....	50
5.11.1 Validation with standard solution.....	50
5.11.2 Validation with applicable laboratory measurement (cuvette test).....	51
5.12 Put the analyzer in shutdown mode.....	53
5.12.1 Prepare the analyzer for storage.....	53
Section 6 Troubleshooting	55
6.1 Troubleshoot the controller.....	55
6.2 Troubleshooting the analyzer.....	55
Section 7 Replacement parts and accessories	59

Section 1 Specifications

Specifications are subject to change without notice.

Specification	Details
Dimensions (W x H x D)	PHOSPHAX sc LR: 540 × 720 × 390 mm (21.25 × 28.35 × 15.35 in.) PHOSPHAX indoor sc LR: 540 × 720 × 370 mm (21.25 × 28.35 × 14.5 in.)
Enclosure	Enclosure rating: PHOSPHAX sc LR, IP55; PHOSPHAX indoor sc LR, IP54 Enclosure material: ASA/PC UV-resistant
Weight	PHOSPHAX sc LR: Approximately 31 kg without chemicals PHOSPHAX indoor sc LR: Approximately 29 kg without chemicals
Measuring method	Two-beam photometer (yellow method)
Measuring range	0.015 to 2 mg/L PO ₄ -P
Detection limit	0.015 mg/L with standard
Measuring accuracy (with standard solution)	2% of the measured value + 0.015 mg/L ¹
Repeatability (with standard solution)	0.7% of the measured value + 0.005 mg/L
Response time (90 %)	10 minutes
Adjustable measuring interval	10 to 120 minutes
Power supply	With power cable, connected to a SC1000 controller or SC200 with power box. Analyzer and drain tubing: 115 V or 230 V versions
Data transmission	SC standard
Electrical power consumption	500 VA
Electrical fuse protection	Supplied by SC1000 controller or SC200 controller with power box. Maximum of two analyzers for each SC Controller.
Outputs	Relay, analog outputs, network interface through SC1000/SC200 controller ² .
Operating temperature	PHOSPHAX sc LR: -20 to 40 °C (-4 to 104 °F); 95% relative humidity, non-condensing, non-corrosive PHOSPHAX indoor sc LR: 5 to 40 °C (41 to 104 °F); 95% relative humidity, non-condensing, non-corrosive
Storage temperature	-20 to 60 °C (-4 to 140 °F); 95% relative humidity, non-condensing
Data and power cable lengths	2 m (80 in.) from edge of enclosure
Certifications	CE marked. Listed to UL and CSA safety standards by TÜV.
Warranty	1 year (EU: 2 years)

¹ At room temperature. ± 4% for values > 1 mg/L PO₄-P along the full temperature range.

² Refer to the controller documentation for more information about the relay, analog and digital outputs.

Specifications

1.1 Sample requirements

The water from the sample source(s) must agree with the specifications that follow.

Specification	Description
Sample flow rate	1.0 to 20.0 L/h
Sample pressure	With continuous sample preparation: -30 mbar to +50 mbar at overflow vessel.
Sample temperature	4 to 45 °C (39 to 113 °F)
Sample quality	Ultra filtrated or comparable
Sample pH	5 to 9

1.2 Interferences

Table 1 shows that the ions were individually examined to the given concentrations and do not cause interference. No cumulative effects or influences of other ions were found. Verify the measurement results with sample dilutions or standard additions.

Table 1 Interfering substances

Interfering substance	Interference level
Cl ⁻	5000 mg/L

Section 2 General information

In no event will the manufacturer be liable for direct, indirect, special, incidental or consequential damages resulting from any defect or omission in this manual. The manufacturer reserves the right to make changes in this manual and the products it describes at any time, without notice or obligation. Revised editions are found on the manufacturer's website.

2.1 Safety information

NOTICE

The manufacturer is not responsible for any damages due to misapplication or misuse of this product including, without limitation, direct, incidental and consequential damages, and disclaims such damages to the full extent permitted under applicable law. The user is solely responsible to identify critical application risks and install appropriate mechanisms to protect processes during a possible equipment malfunction.

Please read this entire manual before unpacking, setting up or operating this equipment. Pay attention to all danger and caution statements. Failure to do so could result in serious injury to the operator or damage to the equipment.

Make sure that the protection provided by this equipment is not impaired. Do not use or install this equipment in any manner other than that specified in this manual.

2.1.1 Use of hazard information

⚠ DANGER

Indicates a potentially or imminently hazardous situation which, if not avoided, will result in death or serious injury.

⚠ WARNING

Indicates a potentially or imminently hazardous situation which, if not avoided, could result in death or serious injury.

⚠ CAUTION



Indicates a potentially hazardous situation that may result in minor or moderate injury.

NOTICE









Indicates a situation which, if not avoided, may cause damage to the instrument. Information that requires special emphasis.

2.1.2 Precautionary labels

Read all labels and tags attached to the instrument. Personal injury or damage to the instrument could occur if not observed. A symbol on the instrument is referenced in the manual with a precautionary statement.

	This symbol, if noted on the instrument, references the instruction manual for operation and/or safety information.
	Electrical equipment marked with this symbol may not be disposed of in European domestic or public disposal systems. Return old or end-of-life equipment to the manufacturer for disposal at no charge to the user.
	This symbol indicates that a risk of electrical shock and/or electrocution exists.

General information

	This symbol indicates the need for protective eye wear.
	This symbol indicates that the marked item requires a protective earth connection. If the instrument is not supplied with a ground plug on a cord, make the protective earth connection to the protective conductor terminal.
	This symbol, when noted on the product, identifies the location of a fuse or current limiting device.
	This symbol identifies a risk of chemical harm and indicates that only individuals qualified and trained to work with chemicals should handle chemicals or perform maintenance on chemical delivery systems associated with the equipment.
	This symbol indicates that the marked item can be hot and should not be touched without care.
	This symbol indicates the presence of devices sensitive to Electro-static Discharge (ESD) and indicates that care must be taken to prevent damage with the equipment.
	This symbol indicates that the object is heavy.
	This symbol indicates that the marked item should not be touched.

2.1.3 Chemical and biological safety

⚠ DANGER	
	Chemical or biological hazards. If this instrument is used to monitor a treatment process and/or chemical feed system for which there are regulatory limits and monitoring requirements related to public health, public safety, food or beverage manufacture or processing, it is the responsibility of the user of this instrument to know and abide by any applicable regulation and to have sufficient and appropriate mechanisms in place for compliance with applicable regulations in the event of malfunction of the instrument.

2.1.4 Certification

⚠ CAUTION
This equipment is not intended for use in residential environments and may not provide adequate protection to radio reception in such environments.

Canadian Radio Interference-Causing Equipment Regulation, ICES-003, Class A:

Supporting test records reside with the manufacturer.

This Class A digital apparatus meets all requirements of the Canadian Interference-Causing Equipment Regulations.

Cet appareil numérique de classe A répond à toutes les exigences de la réglementation canadienne sur les équipements provoquant des interférences.

FCC Part 15, Class "A" Limits

Supporting test records reside with the manufacturer. The device complies with Part 15 of the FCC Rules. Operation is subject to the following conditions:

1. The equipment may not cause harmful interference.
2. The equipment must accept any interference received, including interference that may cause undesired operation.

Changes or modifications to this equipment not expressly approved by the party responsible for compliance could void the user's authority to operate the equipment. This equipment has been tested and found to comply with the limits for a Class A digital device, pursuant to Part 15 of the FCC rules. These limits are designed to provide reasonable protection against harmful interference when the equipment is operated in a commercial environment. This equipment generates, uses and can radiate radio frequency energy and, if not installed and used in accordance with the instruction manual, may cause harmful interference to radio communications. Operation of this equipment in a residential area is likely to cause harmful interference, in which case the user will be required to correct the interference at their expense. The following techniques can be used to reduce interference problems:

1. Disconnect the equipment from its power source to verify that it is or is not the source of the interference.
2. If the equipment is connected to the same outlet as the device experiencing interference, connect the equipment to a different outlet.
3. Move the equipment away from the device receiving the interference.
4. Reposition the receiving antenna for the device receiving the interference.
5. Try combinations of the above.

2.2 Product overview

The PHOSPHAX sc LR is a one-channel analyzer that measures ortho-phosphate ions (PO_4^{3-}) in waste water and surface water. The analyzer does not measure diphosphates or polyphosphates. The measuring principle is based on the Vanadat-Molybdat method, also known as the Yellow method.

The analyzer is used with an SC Controller. The measured value shows on the controller display as $\text{PO}_4\text{-P}$ (default) or PO_4^{3-} .

There are two analyzer models available:

- PHOSPHAX sc LR: weather-resistant enclosure for outdoor installation
- PHOSPHAX indoor sc LR: for indoor installation

The reagents and standards necessary for the chemical analysis are internally installed in the analyzer enclosure. The analyzer uses pumps, valves and syringes to move the sample and reagents to the measuring cell on the analytics panel. When the measurement cycle is complete, the analyzer discards the sample through the drain line. The analyzer can automatically do cleaning cycles and calibrations for better measurement performance. Refer to [Figure 1](#).

The sample must be prepared and filtered before analysis. Refer to [Sample requirements](#) on page 4. Based on the system configuration, one or two analyzers can connect to a FILTRAX instrument for filtration (or an applicable sample feed) and measure one or two parameters. Refer to [System configuration options](#) on page 16.

General information

Figure 1 Product overview

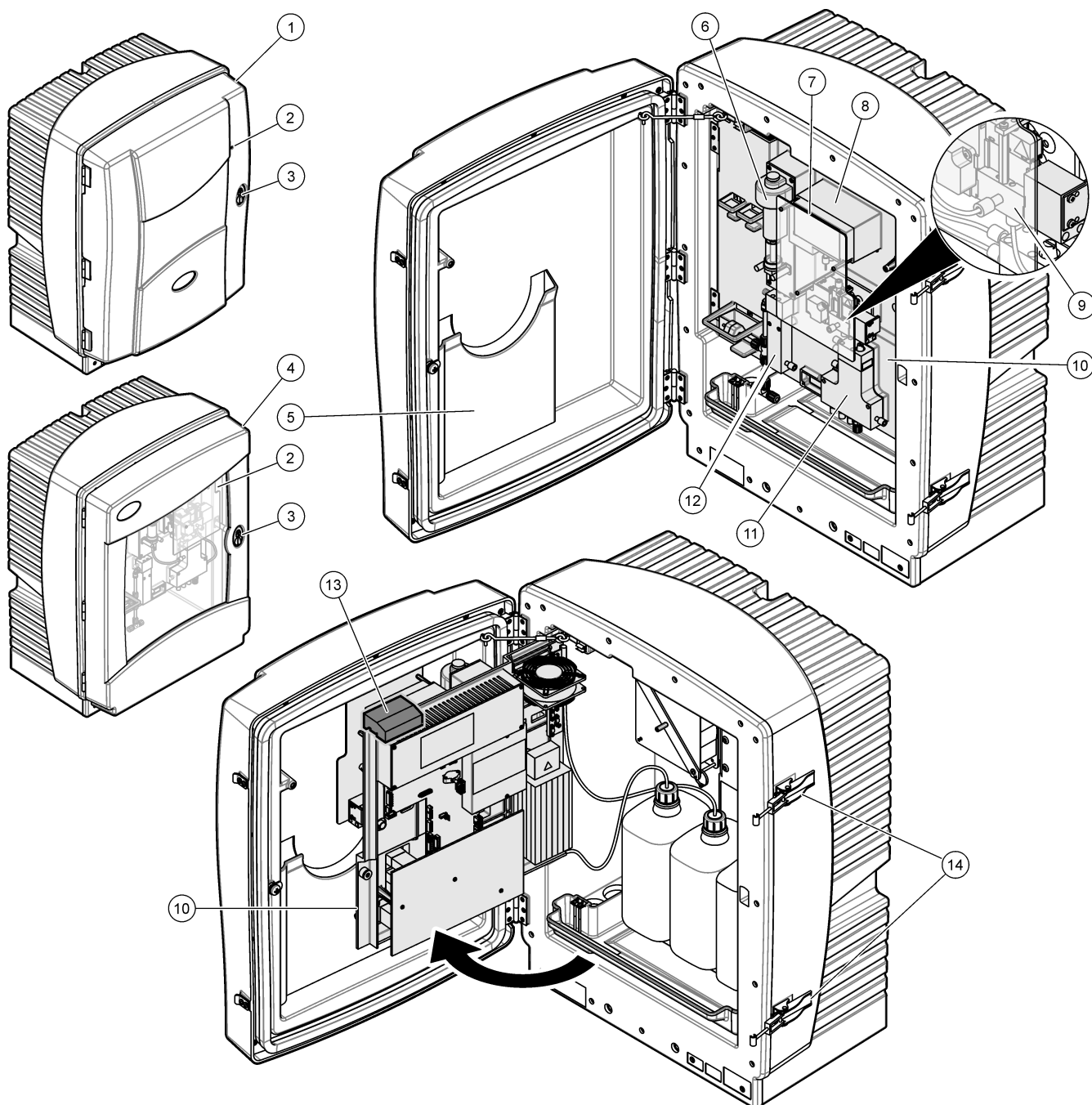

1 PHOSPHAX sc LR	6 Piston pump	11 Valve block
2 Status indicator light ³	7 Safety glass	12 Overflow vessel
3 Door lock	8 Reagent pumps	13 Transport lock ⁴
4 PHOSPHAX indoor sc LR	9 Measuring cell	14 Lever
5 Pocket for manual (only in outdoor models)	10 Analytics panel	

³ Refer to [Status indicator light](#) on page 9.

⁴ Refer to [Remove the transport lock](#) on page 14.

2.2.1 Status indicator light

The status indicator light shows the analyzer condition. Refer to [Table 2](#).

Table 2 Status indicator description

Color	Status
Green	The analyzer is in operation with no warnings, errors or reminders.
Orange	The analyzer is in operation with active warnings or reminders.
Red	The analyzer is not in operation because of an error condition. An important problem has occurred. It is necessary to resolve the error before further operation is possible.
Flashing	There is no communications between the analyzer and the controller.

2.3 Product components

Make sure that all components have been received. Refer to [Figure 2](#). If any items are missing or damaged, contact the manufacturer or a sales representative immediately.

General information

Figure 2 Product components

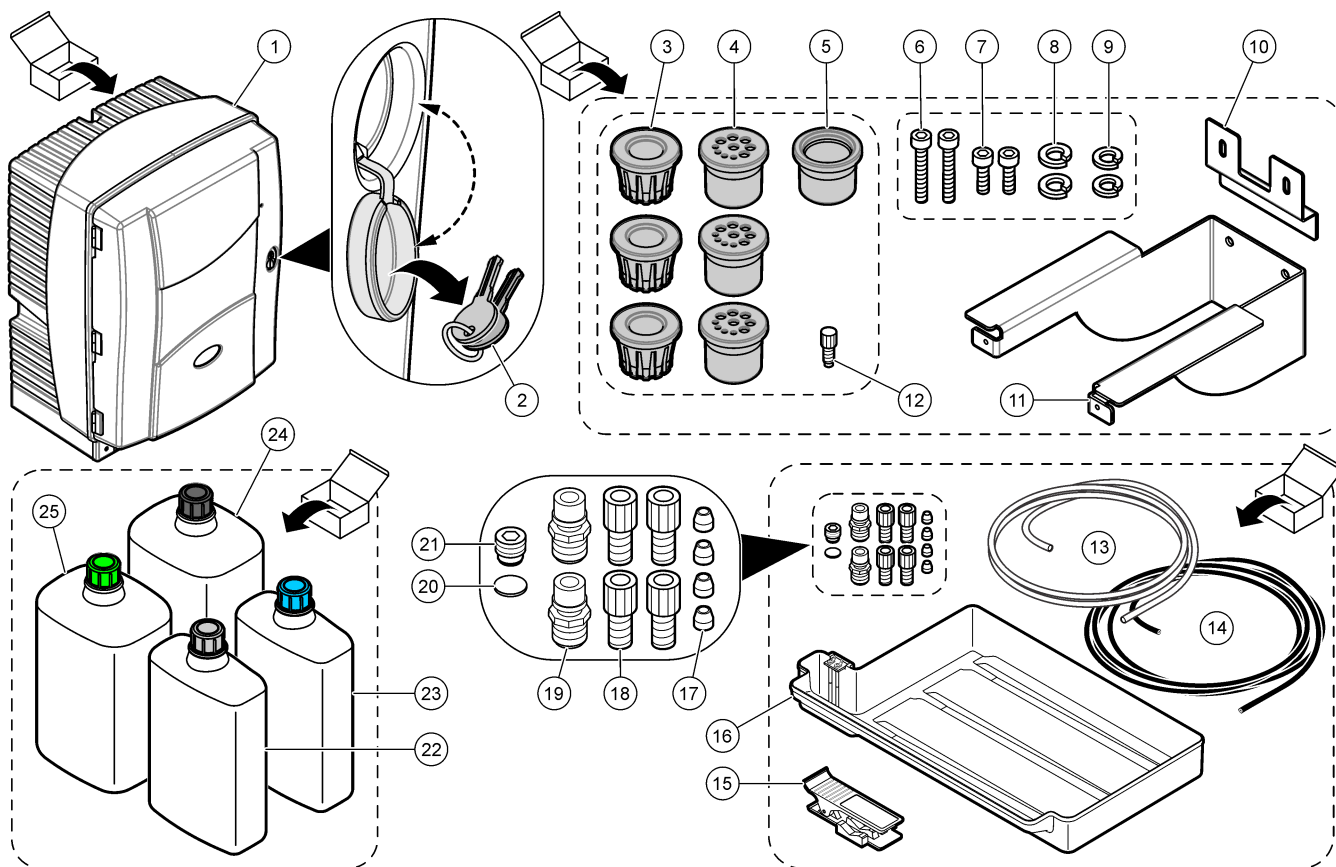

1 PHOSPHAX sc LR	10 Angle bracket, wall mount	19 Hose plug (2x)
2 Door keys	11 Console bracket, wall mount	20 Sealing disc
3 Tubing plug (3x)	12 Blind plug	21 Blind plug
4 Sealing plug (3x)	13 Sample tube	22 Cleaning Solution C
5 Sealing plug type 2 (not used)	14 Drain tube	23 Standard Solution S
6 Screw, M5 × 40 (2x)	15 Tube cutter	24 Reagent A
7 Screw, M5 × 8 (2x)	16 Collecting tray	25 Reagent B
8 Lock washer, M5 (2x)	17 Ferrule (4x)	
9 Lock washer, M6 (2x)	18 Flangeless nut (4x)	

Section 3 Installation

DANGER



Multiple hazards. Only qualified personnel must conduct the tasks described in this section of the document.

3.1 Installation guidelines

Install the instrument:

- As near the sample source as possible to decrease analysis delay
- In a clean, dry, well ventilated and temperature controlled location
- In a location with minimum vibrations that has no direct exposure to sunlight
- In an environmental enclosure that supplies protection from precipitation and direct sunlight, good ventilation and temperature control if installed outdoors
- In a location where the power switch and power cord are visible and easily accessible
- In a location where there is sufficient clearance around it to make plumbing and electrical connections

3.2 Mechanical installation

3.2.1 Attach the instrument to a wall

DANGER



Risk of injury or death. Make sure that the wall mounting is able to hold 4 times the weight of the equipment.

CAUTION



Personal injury hazard.
Instruments or components are heavy. Use assistance to install or move.
The object is heavy. Make sure that the instrument is securely attached to a wall, table or floor for a safe operation.

Attach the instrument upright and level on a flat, vertical surface. Keep a minimum clearance of 813 mm (32 in.) in front of the instrument to open the door. Refer to [Figure 3](#). Mounting hardware is supplied by the user. Make sure that the fastening has sufficient load bearing capacity (approximately 160 kg). The wall plugs must be selected and approved to suit the properties of the wall. Refer to the illustrated steps that follow.

For rail mount and stand mount installations, refer to the documentation supplied with the mounting hardware.

Installation

Figure 3 Mounting dimensions

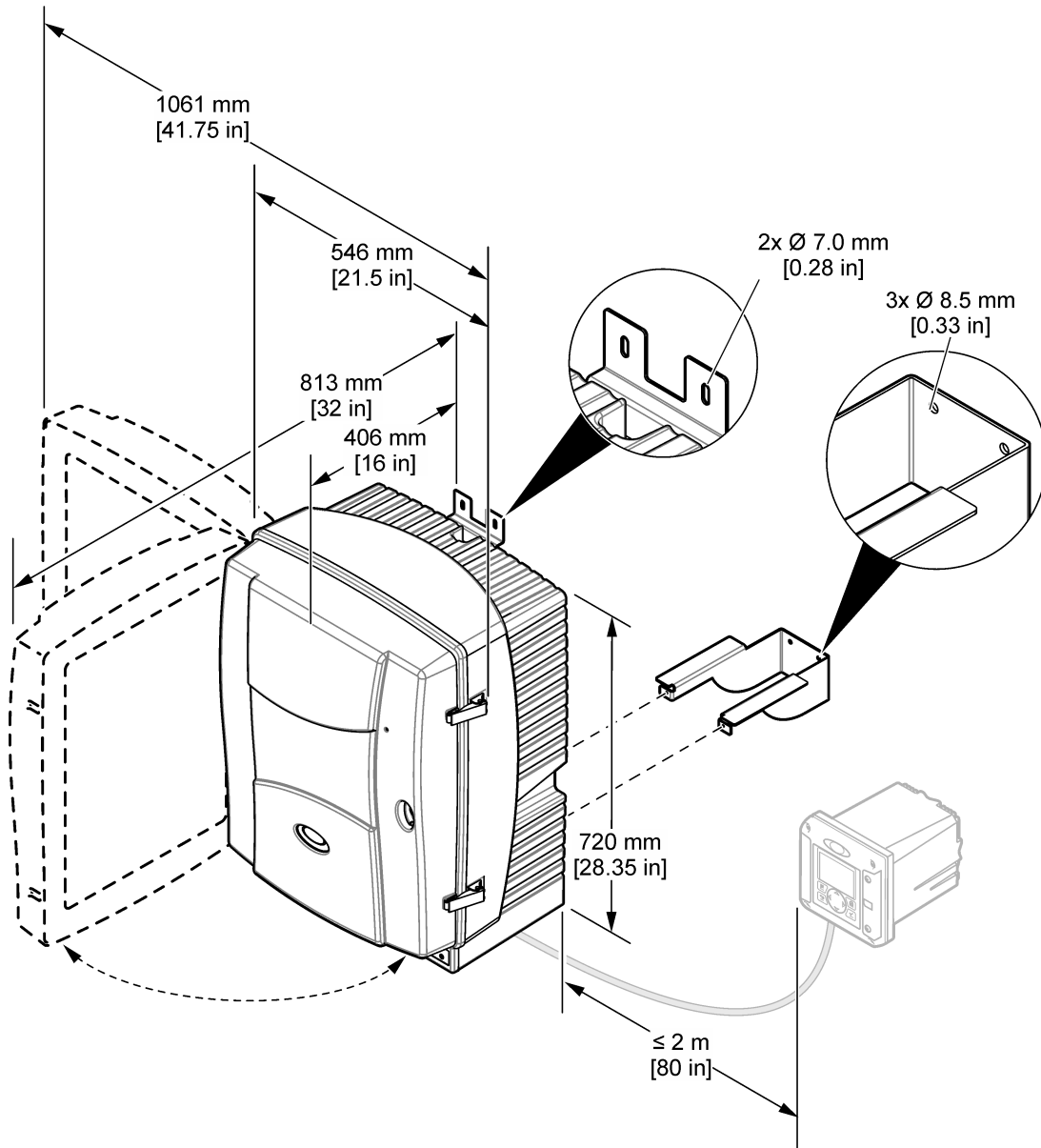

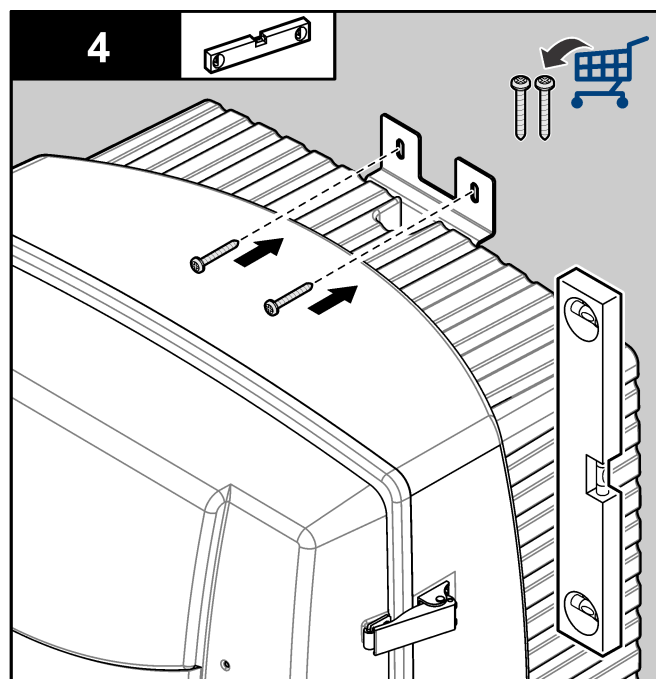
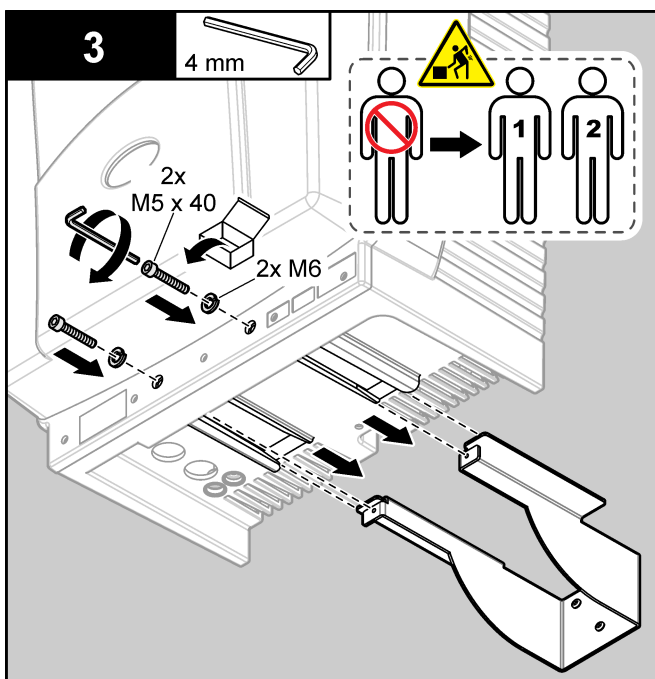
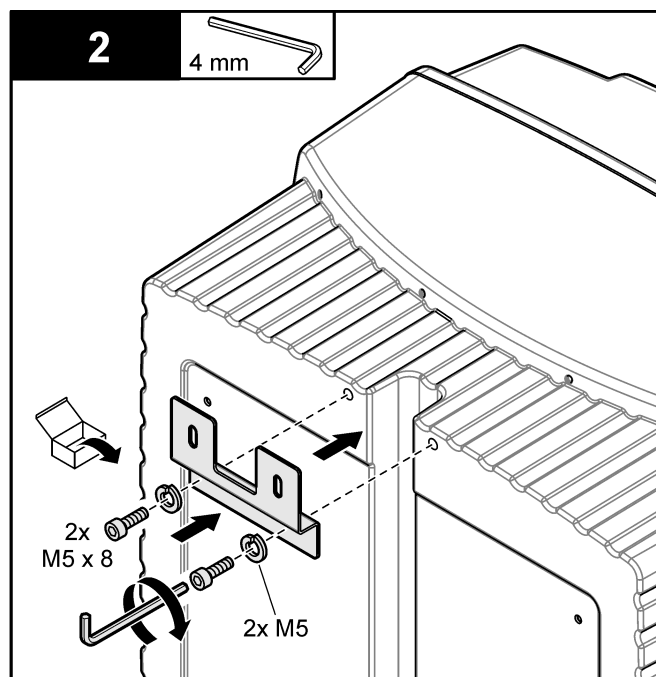
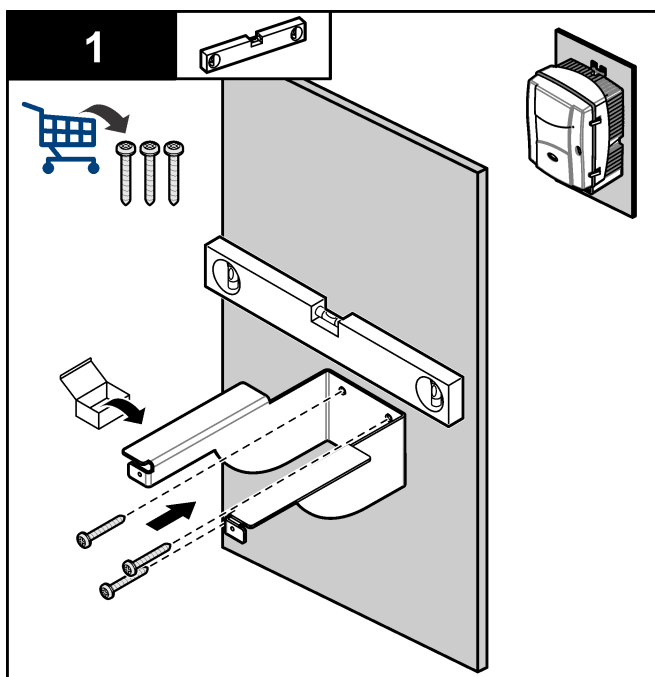

3.2.2 Open the enclosure

⚠ CAUTION



Personal injury hazard. The object is heavy. Make sure that the instrument is securely attached to a wall, table or floor for a safe operation.

⚠ CAUTION



Electrical shock hazard. Make sure that no water can enter the enclosure or come into contact with the circuit boards.

Open the analyzer enclosure to get access to the wiring connections and plumbing.

Use the door hook to open the door safely. Refer to the illustrated steps that follow.

Figure 4 Open the door

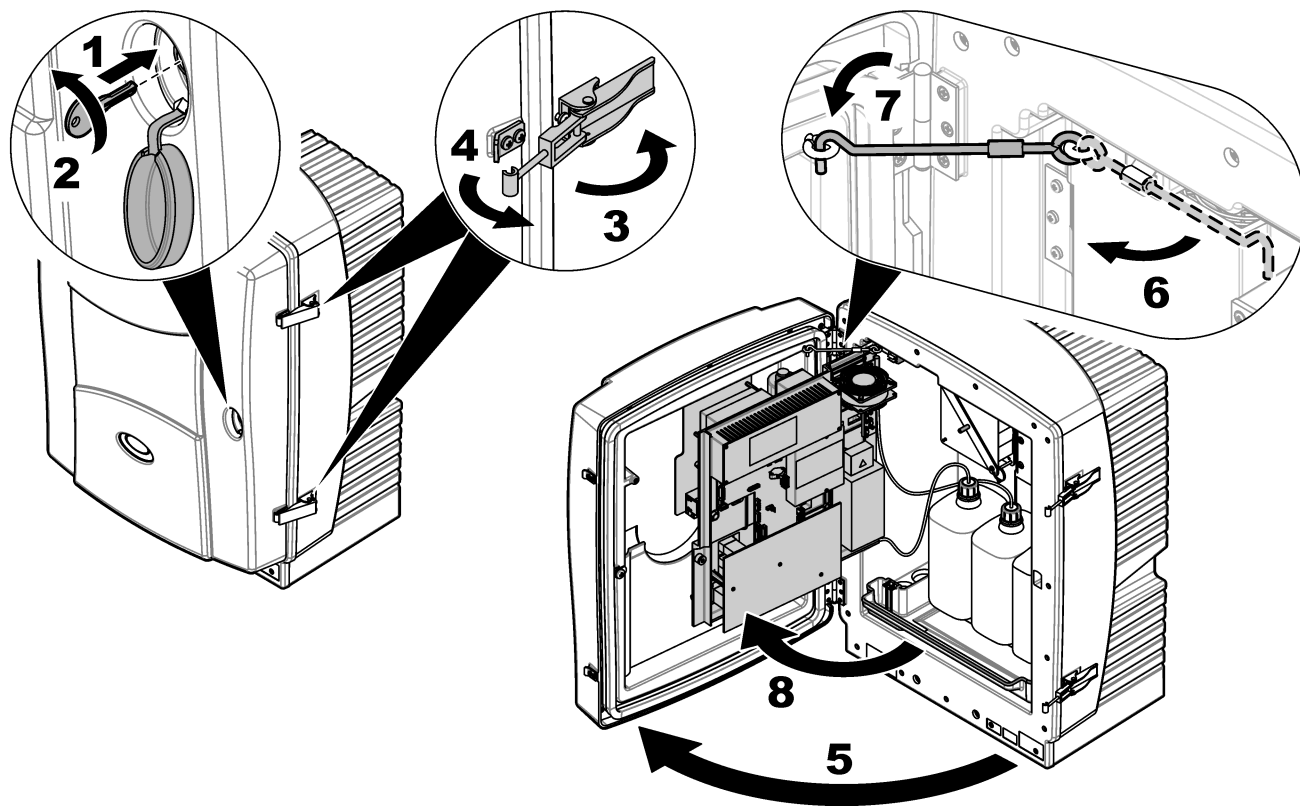

As an alternative, remove the door for better access during installation and maintenance procedures. Refer to [Figure 5](#). Make sure to install and close the door before operation.

Figure 5 Remove the door

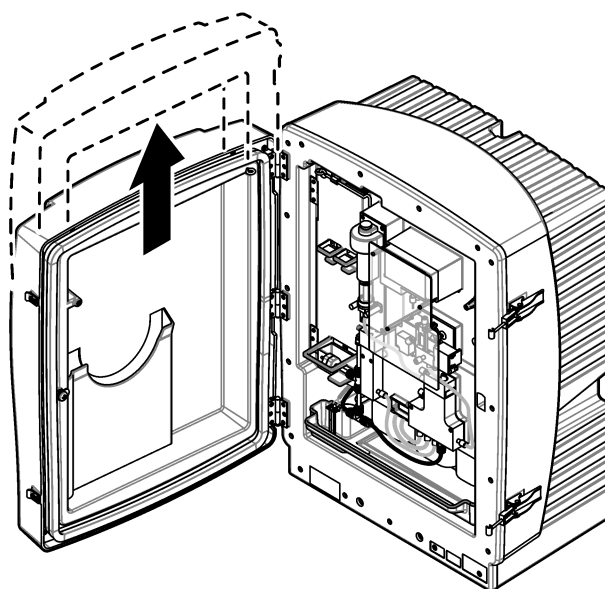

3.2.3 Remove the transport lock

Remove the transport lock from the analyzer. Refer to [Figure 1](#) on page 8.

Note: Keep the transport lock for storage or shipping.

3.3 Electrical connectors and plumbing access ports

Figure 6 shows the electrical connectors and fittings on the instrument. Use the tubing plug to put tubing or cables through the analyzer access ports. To keep the environmental rating of the enclosure, make sure that there is a sealing plug in the access ports that are not used.

Refer to [System configuration options](#) on page 16 to find the correct plumbing installation.

Figure 6 Electrical connectors and fittings

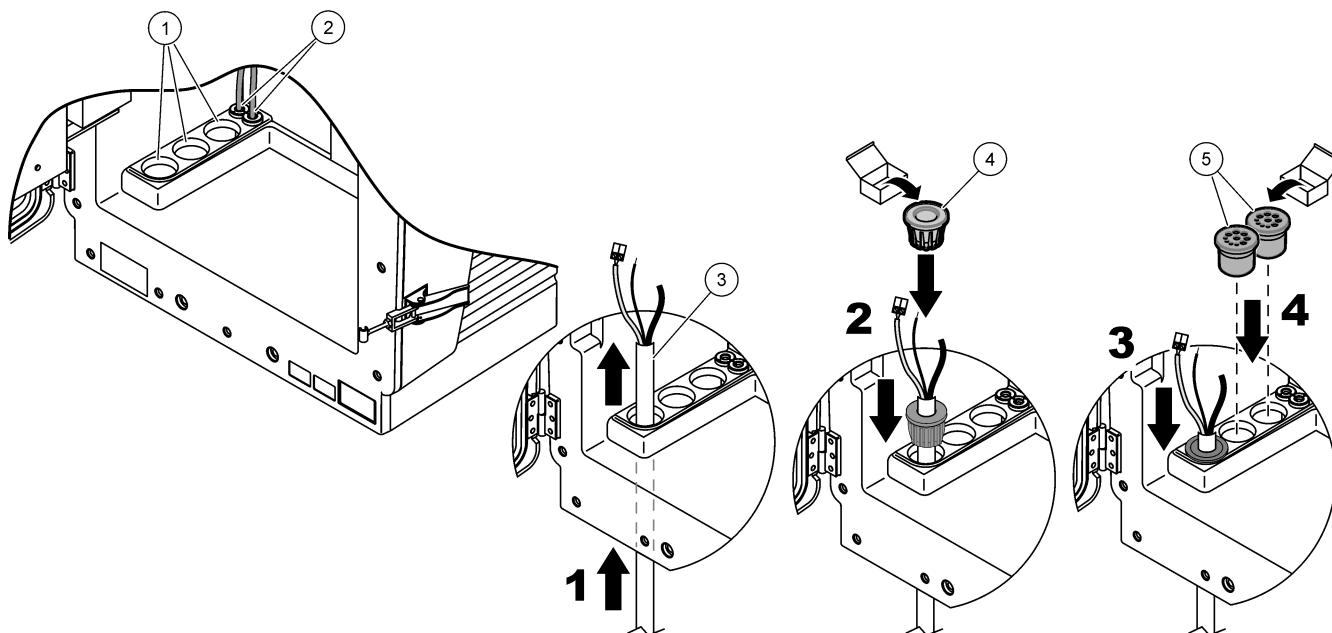

1 Analyzer access ports	4 Tubing plug
2 Power and data connections (factory installed)	5 Sealing plug ⁵ .
3 Tubing or cables	

3.4 Plumbing

⚠ DANGER



Fire hazard. This product is not designed for use with flammable liquids.

NOTICE

Do not install reagents until all plumbing is complete.

Make sure to use the specified tubing size.

3.4.1 Sample line guidelines

Select a good, representative sampling point for the best instrument performance. The sample must be representative of the entire system.

To prevent erratic readings:

- Collect samples from locations that are sufficiently distant from points of chemical additions to the process stream.

⁵ Use the sealing plug to close access ports that are not used.

Installation

- Make sure that the samples are sufficiently mixed.
- Make sure that all chemical reactions are complete.

3.4.2 Drain line guidelines

NOTICE

Incorrect installation of the drain lines can cause liquid to go back into the instrument and cause damage.

- Make the drain lines as short as possible.
- Make sure that the drain lines have a constant slope down.
- Make sure that the drain lines do not have sharp bends and are not pinched.
- Make sure that the drain lines are open to air and are at zero back pressure.

3.4.3 Tubing considerations

Plan cable and tubing path to prevent sharp bends and tripping hazards. The analyzer uses different tubing types for plumbing connections. The type of tubing is based on the analyzer configuration:

- Ø 3.2 mm: sample line tubing
- Ø 6 mm: unheated drain tubing
- Ø 22 mm: heated drain tubing

Always put the drain tubing so that there is a continuous fall (minimum 3°) and the outlet is open to air (not pressurized). Make sure the drain tubing is less than 2 meters (6.56 ft).

3.5 System configuration options

Before plumbing or electrical installation, find the correct system configuration option based on the number of analyzers, sample filtration, drain line and number of measured parameters⁶. Refer to [Table 3](#).

Table 3 System configuration options

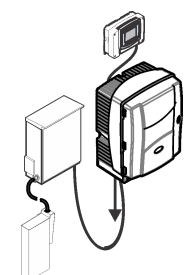
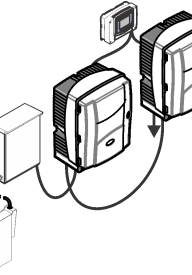
Location	Filtration	Drain	Number of analyzers	Number of parameters	Plumbing option
Outdoor	FILTRAX	Heated	1	1	 <p>Refer to Plumbing one outdoor analyzer on page 18.</p>
		2 heated	2	2	 <p>Refer to Plumbing two outdoor analyzers on page 19.</p>

⁶ Refer to [Two-parameter configuration](#) on page 29.

Table 3 System configuration options (continued)



Location	Filtration	Drain	Number of analyzers	Number of parameters	Plumbing option	
Outdoor	Continuous sample feed	Heated	1	1	 <p>Refer to Plumbing one outdoor analyzer with continuous sample feed on page 21.</p>	
		2 heated	2	2	 <p>Refer to Plumbing two outdoor analyzers with continuous sample feed on page 22.</p>	
Indoor	FILTRAX	Unheated	1	1	 <p>Refer to Plumbing one indoor analyzer on page 24.</p>	
		Unheated	2	2	 <p>Refer to Plumbing two indoor analyzers on page 25.</p>	

Table 3 System configuration options (continued)

Location	Filtration	Drain	Number of analyzers	Number of parameters	Plumbing option	
Indoor	Continuous sample feed	Unheated	1	1		Refer to Plumbing one indoor analyzer with continuous sample feed on page 27.
		Unheated	2	2		Refer to Plumbing two indoor analyzers with continuous sample feed on page 27.

3.5.1 Plumbing one outdoor analyzer

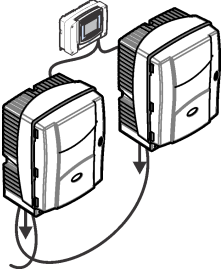
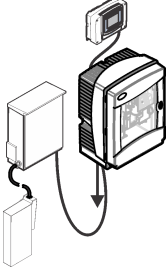
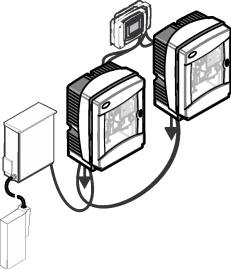
This system configuration option uses one sc analyzer with the FILTRAX instrument for the sample line. The waste from the analyzer is released into an open drain through the optional heated drain hose.

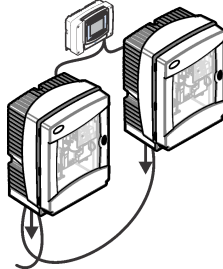
Do the steps that follow to install one outdoor analyzer. Refer to [Figure 7](#).

1. Install the FILTRAX into the sample stream. Refer to the FILTRAX User Manual for more information.
2. Use a tubing plug to put the heated sample hose from the FILTRAX through the analyzer access port.
3. Use a tubing plug to put the heated drain hose through the analyzer access port.
Note: *The two samples lines of the heated drain hose are not used.*
4. Use the sealing plug to close access ports that are not used.
5. Connect the heated drain connections. Refer to [Connect the optional heated drain](#) on page 34.
6. Connect the heated drain tube to the sample outlet T-fitting.

Figure 7 Plumbing one outdoor analyzer

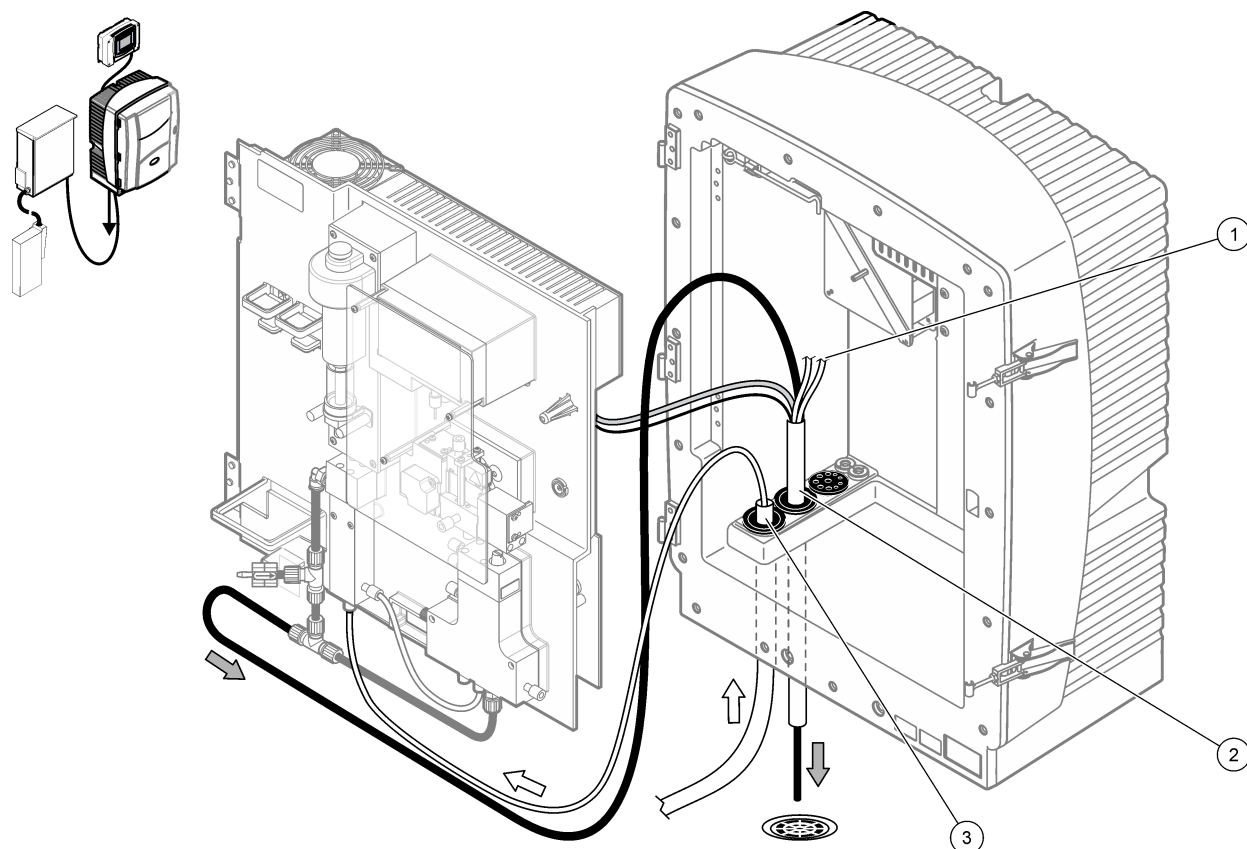

1 Heated drain sample lines (not used)	3 FILTRAX sample line
2 Heated drain	

3.5.2 Plumbing two outdoor analyzers

This system configuration option uses two sc analyzers with the FILTRAX instrument for the sample line. The sample from the FILTRAX goes to the first analyzer, which must change to a 2-parameter configuration. The heated drain hose connects to the two analyzers. The waste from the two analyzers is released into a drain through the second heated drain hose.

Do the steps that follow to install two outdoor analyzers. Refer to [Figure 8](#).

1. Install the FILTRAX into the sample stream. Refer to the FILTRAX User Manual for more information.
Install the first sc analyzer as follows:
2. Use a tubing plug to put the heated sample hose from the FILTRAX through the analyzer access port.
3. Use a tubing plug to put the heated drain hose through the analyzer access port.
4. Use the sealing plug to close access ports that are not used.
5. Connect the heated drain connections. Refer to [Connect the optional heated drain](#) on page 34.
6. Remove the pre-installed drain tube attached to the valve block. Remove the T-fitting from the drain tube. Keep the T-fitting for use with the second analyzer 2.
7. Connect the heated drain tube to the valve block connector.
8. Connect the sample line from the FILTRAX to the bottom inlet on the overflow vessel.
9. Connect one of the sample lines from the heated drain to the overflow vessel.

10. Change the analyzer to a two-parameter configuration. Refer to [Two-parameter configuration](#) on page 29.

Install the second sc analyzer as follows:

11. Use a tubing plug to put the heated drain hose from first analyzer through one access port of second analyzer.
12. Use a tubing plug to put a second heated drain hose through one analyzer access port.
13. Use the sealing plug to close access ports that are not used.
14. Connect the heated drain connections. Refer to [Connect the optional heated drain](#) on page 34.
15. Cut 25 mm (0.98 in.) from the drain tube that was removed from first analyzer.
16. Connect the tube cut to the T-fitting on the second analyzer.
17. Connect the T-fitting removed from first analyzer to the other end of the tube cut.
18. Connect the heated drain tube from first analyzer and second analyzer to the T-fitting.
19. Connect the sample line from first analyzer to the bottom inlet on the overflow vessel.

Figure 8 Plumbing two outdoor analyzers

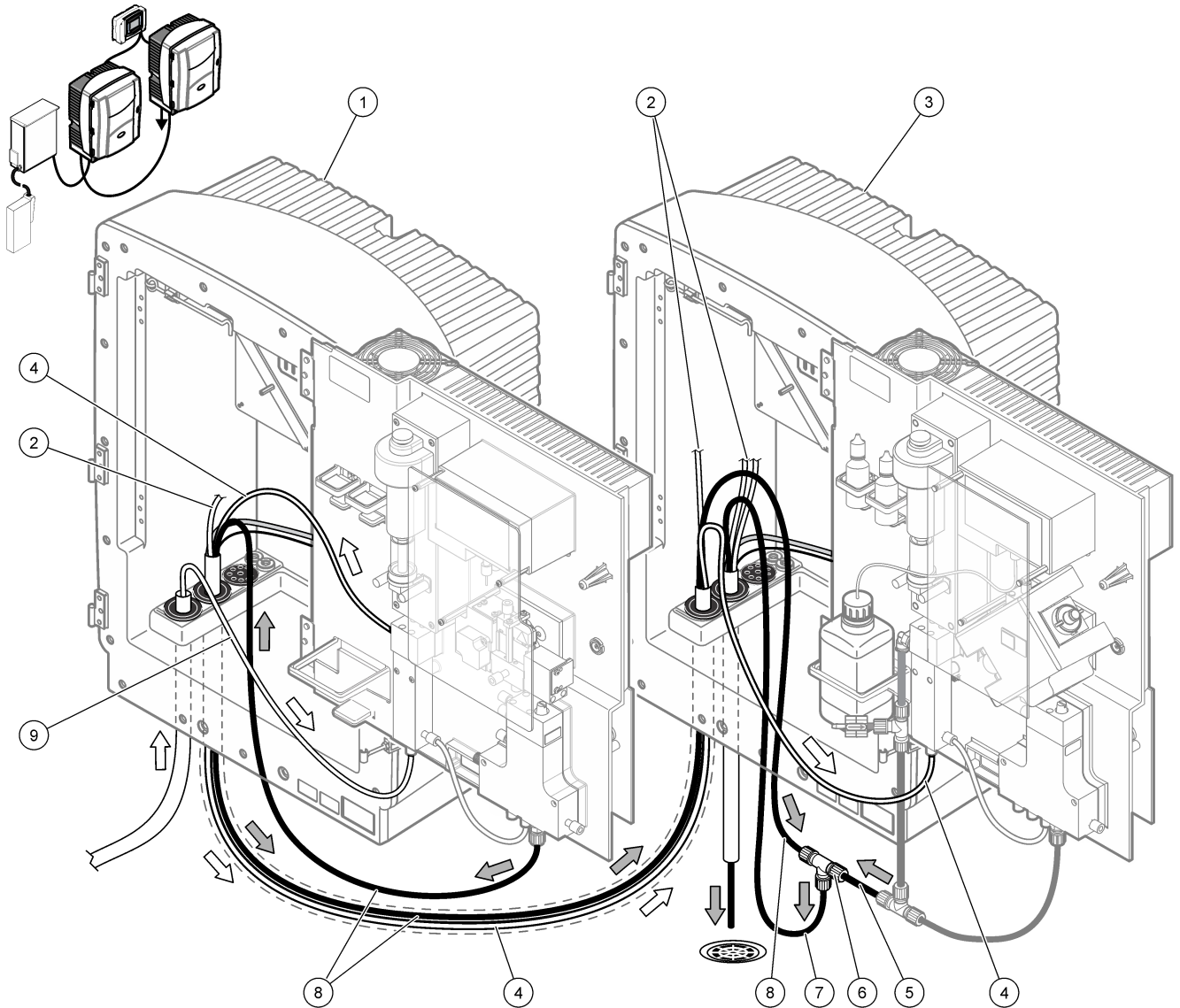

1 PHOSPHAX sc LR analyzer	6 T-fitting from first analyzer
2 Heated drain sample lines (not used)	7 Heated drain
3 AMTAX sc analyzer	8 Heated drain from first analyzer
4 Sample line to second analyzer (overflow vessel tube)	9 FILTRAX sample line
5 Drain tube cut from first analyzer	

3.5.3 Plumbing one outdoor analyzer with continuous sample feed

This configuration option uses one outdoor sc analyzer and one sample preparation unit that supplies a continuous sample stream. The waste from the analyzer is released into an open drain through the optional heated drain hose.

Do the steps that follow to install one outdoor analyzer with continuous sample feed. Refer to [Figure 9](#).

1. Install the sample preparation unit.
2. Use a tubing plug to put the heated sample hose from the sample preparation unit through the analyzer access port.
3. Connect the sample line to the bottom inlet on the overflow vessel.

4. Use a tubing plug to put the heated drain hose through the analyzer access port.
Note: *The two sample lines of the heated drain hose are not used.*
5. Connect the heated drain connections. Refer to [Connect the optional heated drain](#) on page 34.
6. Connect the heated drain tube to the sample outlet T-fitting.
7. Use the sealing plug to close access ports that are not used.

Figure 9 Plumbing one outdoor analyzer with continuous sample feed

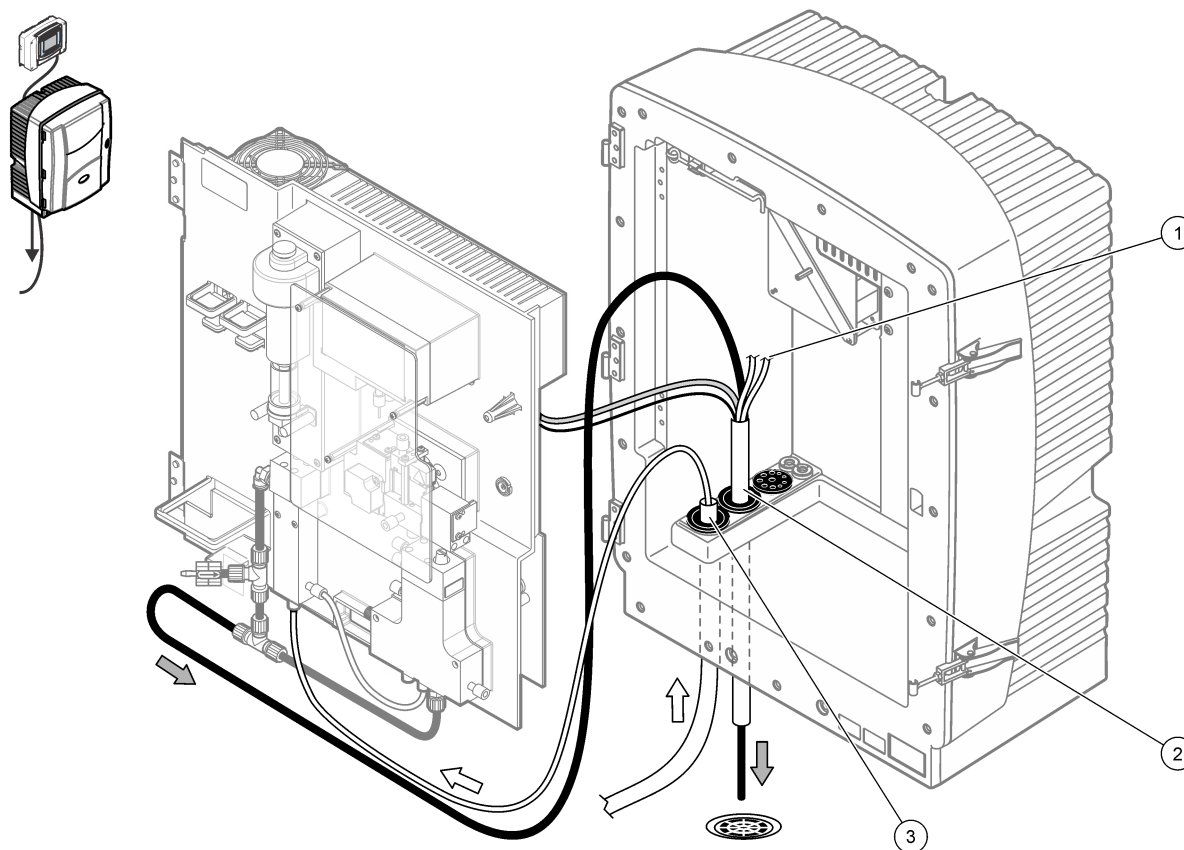

1 Heated drain sample lines (not used)	3 Sample line
2 Drain	

3.5.4 Plumbing two outdoor analyzers with continuous sample feed

This system configuration option uses two outdoor sc analyzers and one sample preparation unit that supplies a continuous sample stream. The sample line from the sample preparation unit goes to the first analyzer, which must change to a 2-parameter configuration. The sample line goes through the two analyzers. The heated drain hose connects to the two analyzers. The waste from the two analyzers is released into a drain through the second heated drain hose.

Do the steps that follow to install two outdoor analyzers with continuous sample feed. Refer to [Figure 10](#).

1. Install the sample preparation unit.
Install the first sc analyzer as follows:
2. Use a tubing plug to put the heated sample hose from the sample preparation unit through the analyzer access port.
3. Use a tubing plug to put the heated drain hose through the analyzer access port.

4. Use the sealing plug to close access ports that are not used.
5. Connect the heated drain connections. Refer to [Connect the optional heated drain](#) on page 34.
6. Remove the pre-installed drain tube attached to the valve block. Remove the T-fitting from the drain tube. Keep the T-fitting for use with the second analyzer 2.
7. Connect the heated drain tube to the valve block connector.
8. Connect the sample line from the sample preparation unit to the bottom inlet of the overflow vessel.
9. Connect one of the sample lines from the heated drain to the overflow vessel.
10. Change the analyzer to a two-parameter configuration. Refer to [Two-parameter configuration](#) on page 29.

Install the second sc analyzer as follows:

11. Use a tubing plug to put the heated drain hose from first analyzer through one access port of second analyzer.
12. Use a tubing plug to put a second heated drain hose through one analyzer access port.
13. Use the sealing plug to close access ports that are not used.
14. Connect the heated drain connections. Refer to [Connect the optional heated drain](#) on page 34.
15. Cut 25 mm (0.98 in.) from the drain tube that was removed from first analyzer.
16. Connect the tube cut to the T-fitting on the second analyzer.
17. Connect the T-fitting removed from first analyzer to the other end of the tube cut.
18. Connect the heated drain tube from first analyzer and second analyzer to the T-fitting.
19. Connect the sample line from first analyzer to the bottom inlet on the overflow vessel.

Figure 10 Plumbing two outdoor analyzers with continuous sample feed

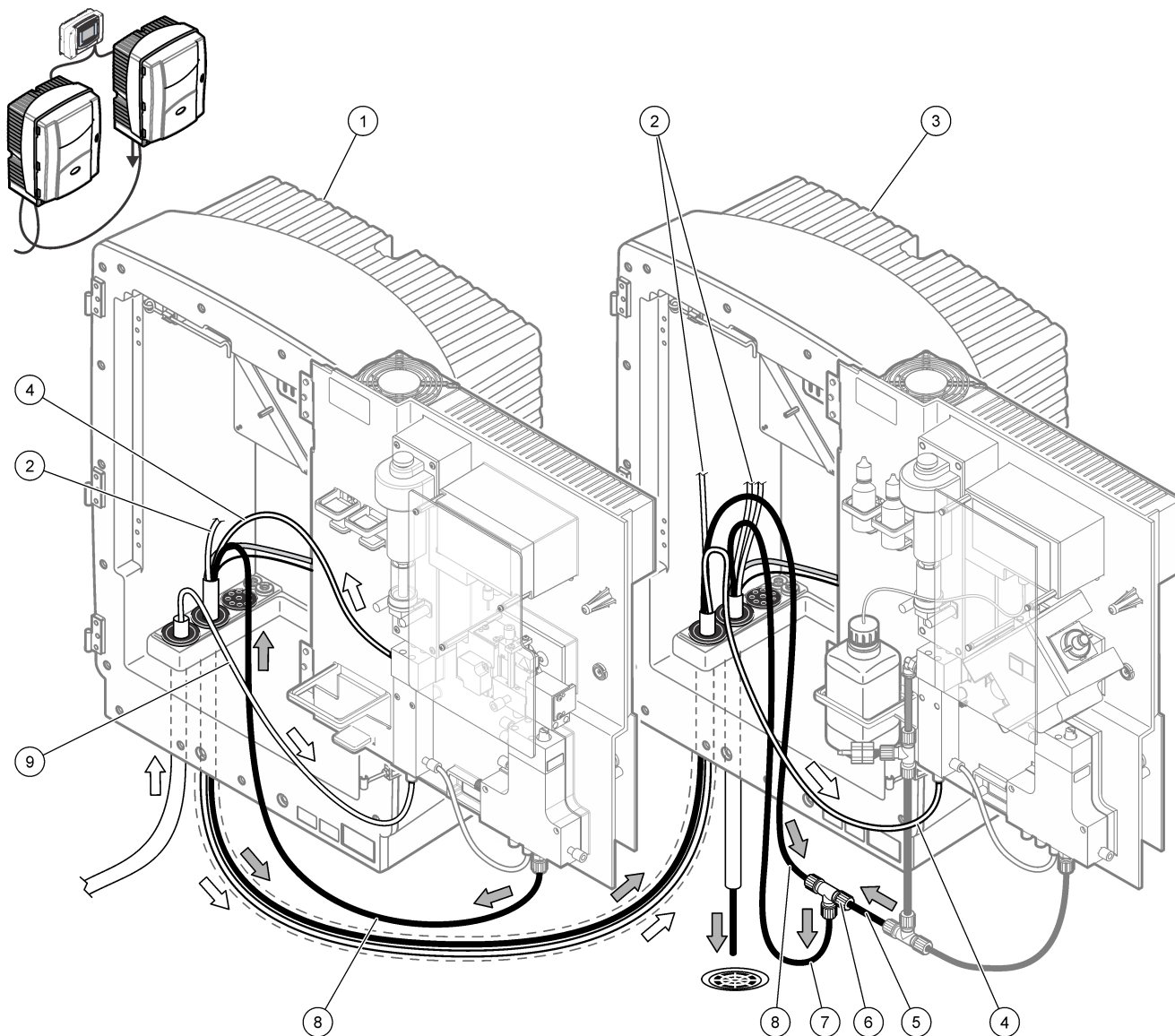

1 PHOSPHAX sc LR analyzer	6 T-fitting from first analyzer
2 Heated drain sample lines (not used)	7 Heated drain
3 AMTAX sc analyzer	8 Heated drain from first analyzer
4 Sample line to second analyzer (overflow vessel tube)	9 Sample line
5 Drain tube cut from first analyzer	

3.5.5 Plumbing one indoor analyzer

This system configuration option uses one indoor sc analyzer with the FILTRAX instrument. The waste of the analyzer is released into an open drain.

Do the steps that follow to install one indoor analyzer. Refer to [Figure 11](#).

1. Install the FILTRAX into the sample stream. Refer to the FILTRAX User Manual for more information.
2. Use a tubing plug to put the heated sample hose from the FILTRAX through the analyzer access port.
3. Connect the FILTRAX sample line to the bottom inlet on the overflow vessel.

4. Use a sealing plug to put the drain tube through the analyzer access port.
Note: Tubes can be pushed through prepared holes on the sealing plug.
5. Connect the drain tube to the T-fitting.
6. Use the sealing plug to close access ports that are not used.
7. Put the drain tube to a lower drain (2 m (6.5 ft) maximum).

Figure 11 Plumbing one indoor analyzer

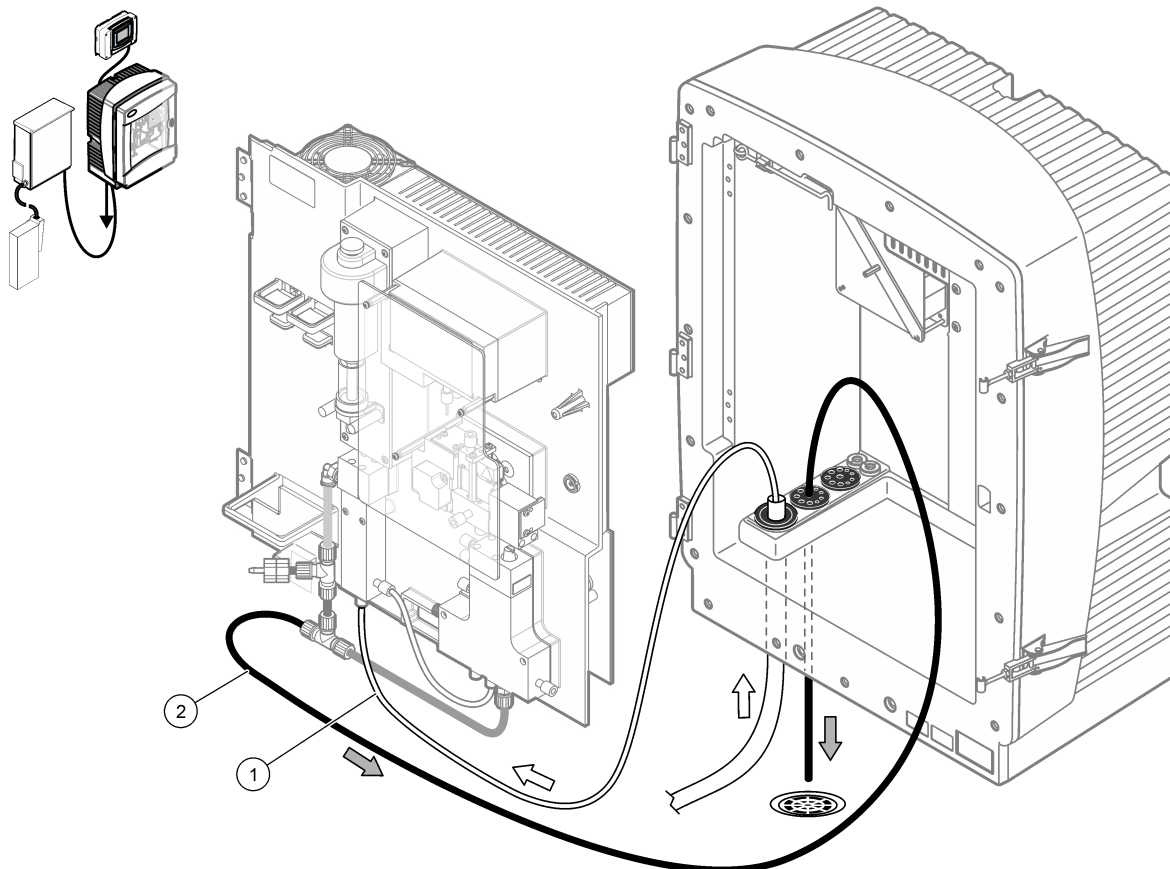

1 FILTRAX sample line

2 Drain

3.5.6 Plumbing two indoor analyzers

This system configuration option uses two indoor sc analyzers with the FILTRAX instrument for the sample line. The sample from the FILTRAX goes to the first analyzer which must change to a 2-parameter configuration. The waste of the two analyzers is released into an open drain.

Do the steps that follow to install two indoor analyzers. Refer to [Figure 12](#).

1. Install the FILTRAX into the sample stream. Refer to the FILTRAX User Manual for more information.
Install the first sc analyzer as follows:
2. Use a tubing plug to put the heated sample hose from the FILTRAX through the analyzer access port.
3. Use a sealing plug to put the drain tube through the analyzer access port.
Note: Tubes can be pushed through prepared holes on the sealing plug.
4. Connect the reworked overflow to supply the sample line to the second analyzer. Use a sealing plug to put the overflow vessel tube through the first analyzer access port to the second analyzer.

5. Remove the drain tube with the T-fitting from the valve block connector. Discard the drain tube.
6. Connect the drain tube to the valve block connector.
7. Connect the sample line from the FILTRAX to the bottom inlet on the overflow vessel.
8. Change the analyzer to a two-parameter configuration. Refer to [Two-parameter configuration](#) on page 29.

Install the second sc analyzer as follows:

9. Use a sealing plug to put the sample line from first analyzer through second analyzer.
10. Use a sealing plug to put the drain tube through the analyzer access port.
- Note: Tubes can be pushed through prepared holes on the sealing plug.*
11. Use the sealing plug to close access ports that are not used.
12. Connect the drain tube to the T-fitting.
13. Connect the sample line to the bottom inlet on the overflow vessel.

Figure 12 Plumbing two indoor analyzers

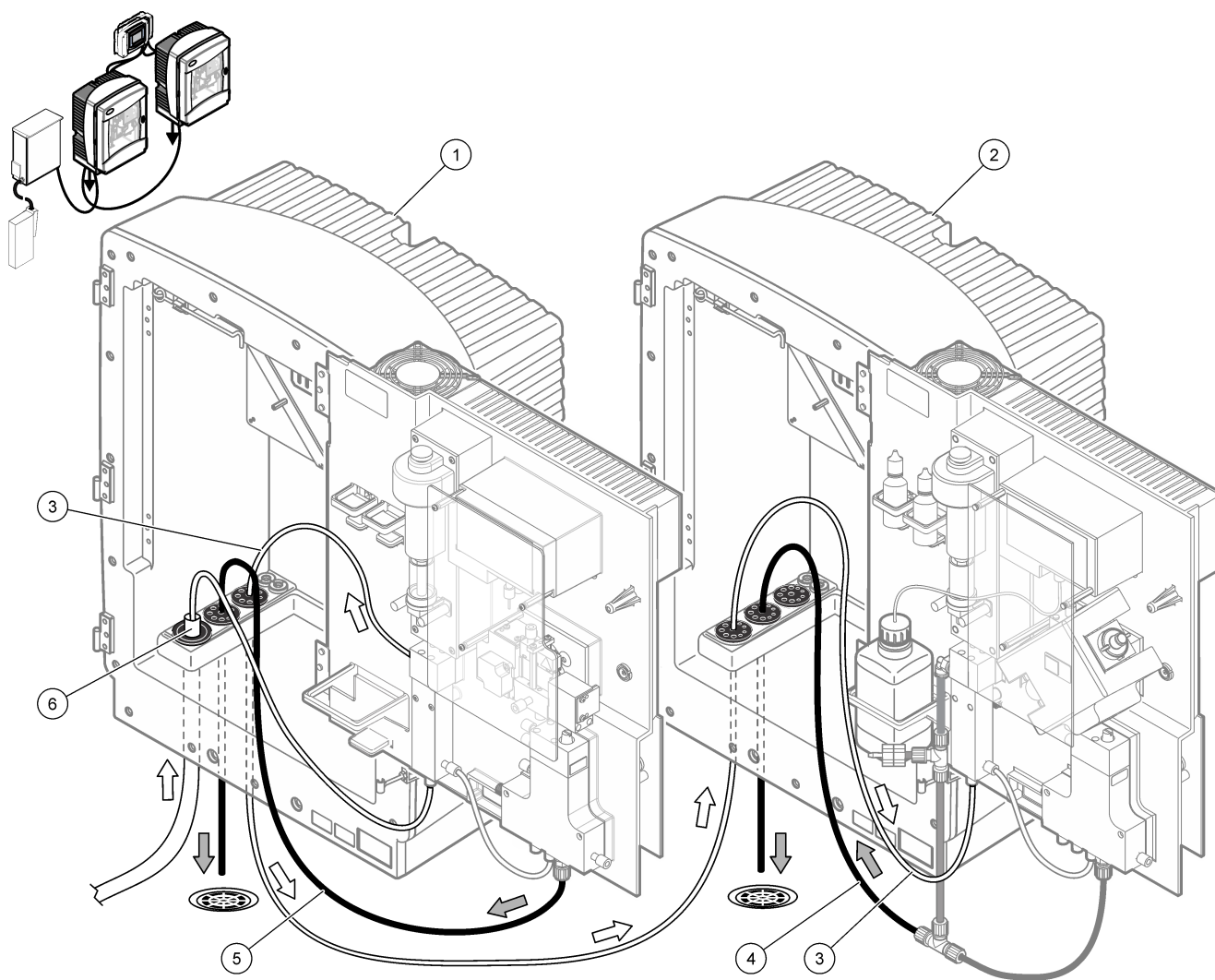

1 PHOSPHAX sc LR analyzer	4 Second analyzer drain
2 AMTAX sc analyzer	5 First analyzer drain
3 Sample line to second analyzer (overflow vessel tube)	6 FILTRAX sample line

3.5.7 Plumbing one indoor analyzer with continuous sample feed

This configuration option uses one indoor sc analyzer and one sample preparation unit that supplies a continuous sample stream. The waste of the analyzer is released into an open drain.

Do the steps that follow to install one indoor analyzer with continuous sample feed. Refer to [Figure 13](#).

1. Install the sample preparation unit.
2. Use a sealing plug to put the sample line from the sample preparation unit through the analyzer access port.
3. Use a sealing plug to put the drain tube through the analyzer access port.
Note: Tubes can be pushed through prepared holes on the sealing plug.
4. Use the sealing plug to close access ports that are not used.
5. Connect the drain tube to the T-fitting.
6. Connect the sample line to the bottom inlet on the overflow vessel.

Figure 13 Plumbing one indoor analyzer with continuous sample feed

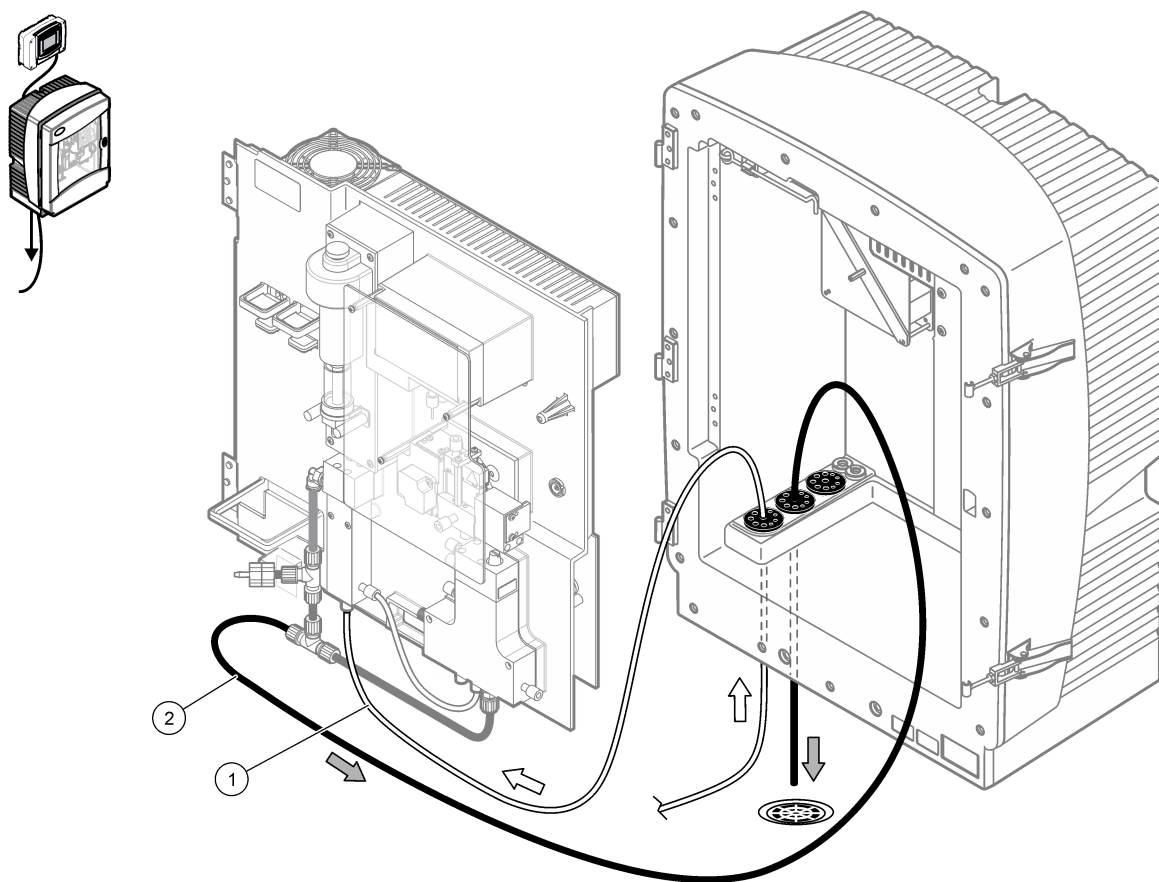

1 Sample line

2 Drain

3.5.8 Plumbing two indoor analyzers with continuous sample feed

This system configuration option uses two indoor sc analyzers and one sample preparation unit that supplies a continuous sample stream. The sample line from the sample preparation unit goes to the first analyzer, which must change to a 2-parameter configuration. The sample line goes through the two analyzers. The waste of the two analyzers is released into an open drain.

Do the steps that follow to install two indoor analyzers with continuous sample feed. Refer to [Figure 14](#).

1. Install the sample preparation unit.

Install the first sc analyzer as follows:

2. Use a sealing plug to put the sample line from the sample preparation unit through the analyzer access port.
3. Use a sealing plug to put the drain tube through the analyzer access port.
Note: Tubes can be pushed through prepared holes on the sealing plug.
4. Remove the drain tube from the valve block connector.
5. Connect the sample line to the bottom inlet on the overflow vessel.
6. Connect the reworked overflow to supply the sample line to the second analyzer. Use a sealing plug to put the overflow vessel tube through the first analyzer access port to the second analyzer.
7. Change the analyzer to a two-parameter configuration. Refer to [Two-parameter configuration](#) on page 29.

Install the second sc analyzer as follows:

8. Use a sealing plug to put the sample line from first analyzer through second analyzer.
9. Use a sealing plug to put the drain tube through the analyzer access port.
Note: Tubes can be pushed through prepared holes on the sealing plug.
10. Connect the drain tube to the T-fitting.
11. Connect the sample line to the bottom inlet on the overflow vessel.

Figure 14 Plumbing two indoor analyzers with continuous sample feed

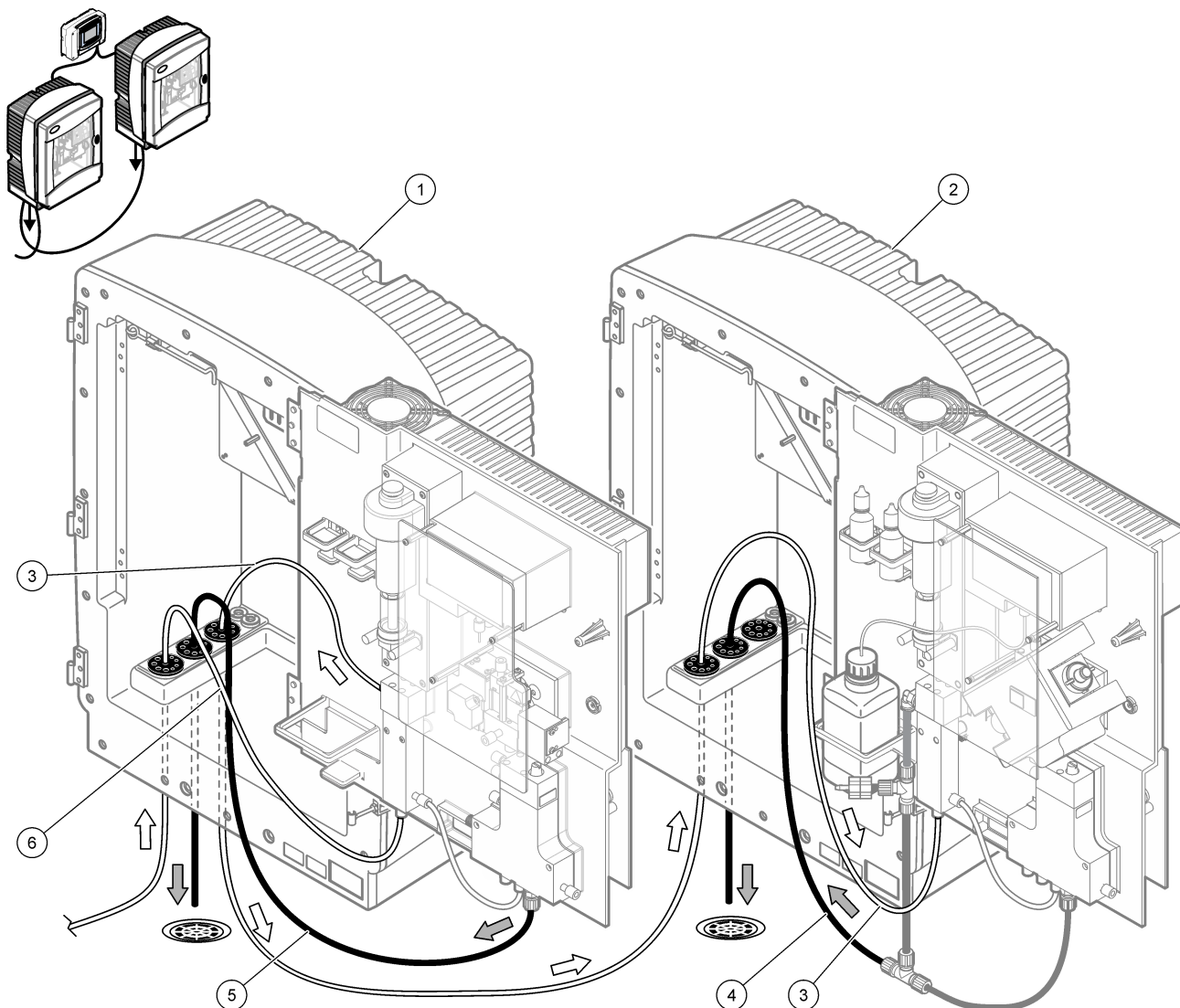

1 PHOSPHAX sc LR analyzer	4 Second analyzer drain
2 AMTAX sc analyzer	5 First analyzer drain
3 Sample line to second analyzer (overflow vessel tube)	6 Sample line

3.5.9 Two-parameter configuration

Use one Phosphax sc LR to measure one parameter in a continuous sample: PO₄-P. Use a second analyzer to measure a second parameter with the same continuous sample (i.e., ammonium measured by the AMTAX sc analyzer). Change the Phosphax sc LR to a 2-parameter configuration. Connect the sample line to the overflow vessel. Remove the T-fitting from the first analyzer drain and use the T-fitting to connect the drain tube from the first analyzer to the second analyzer.

Refer to the illustrated steps that follow.

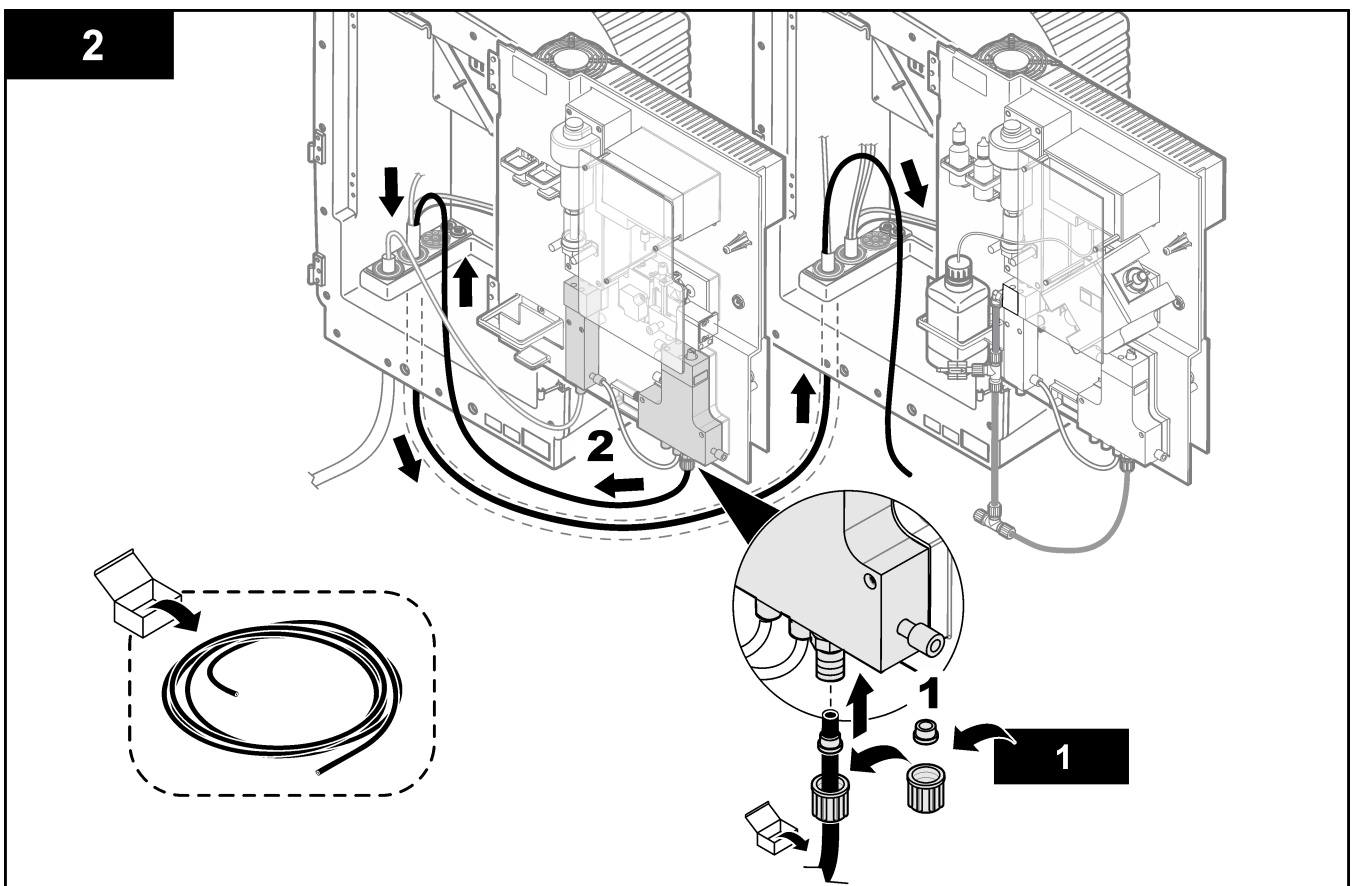
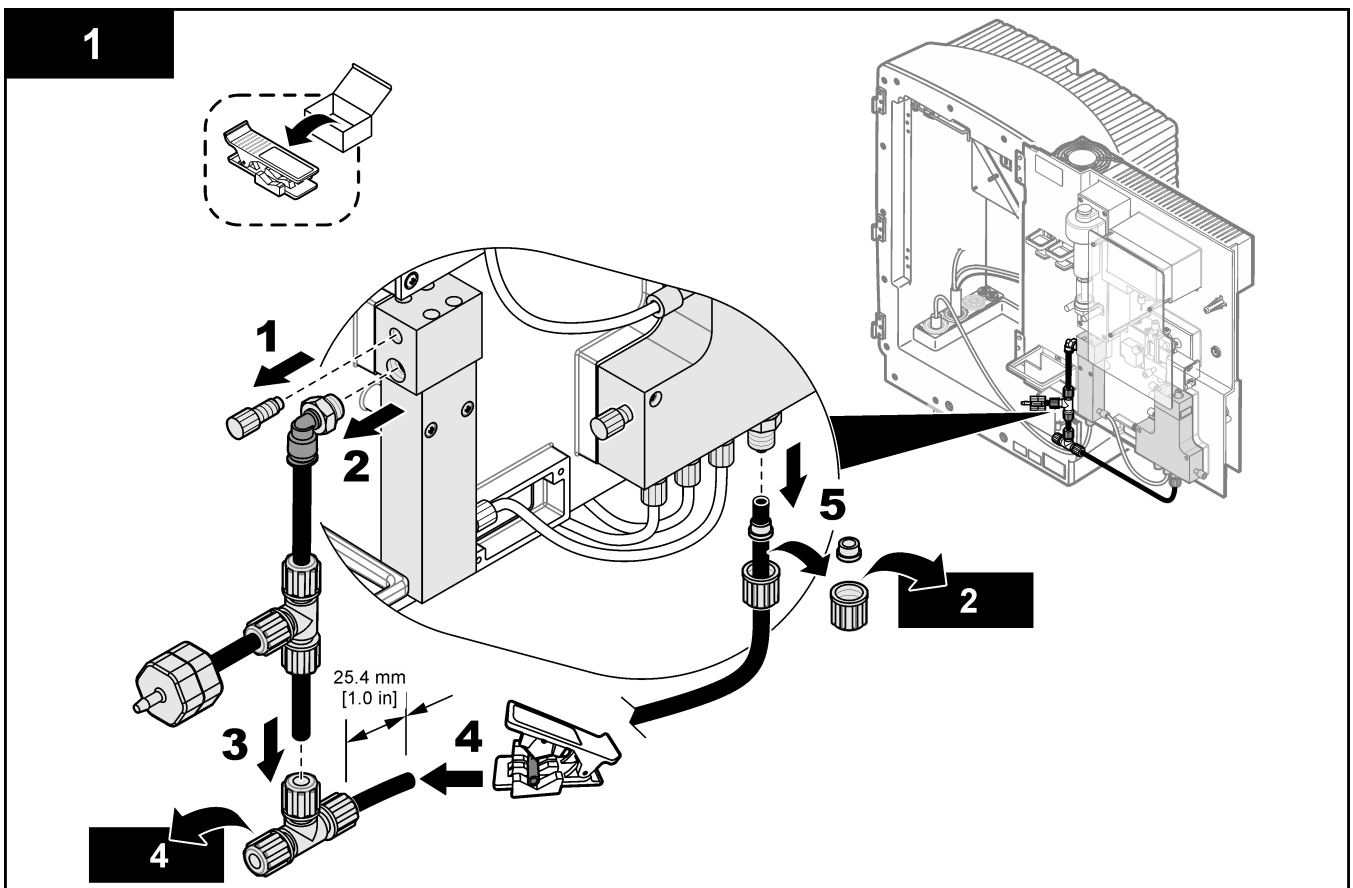

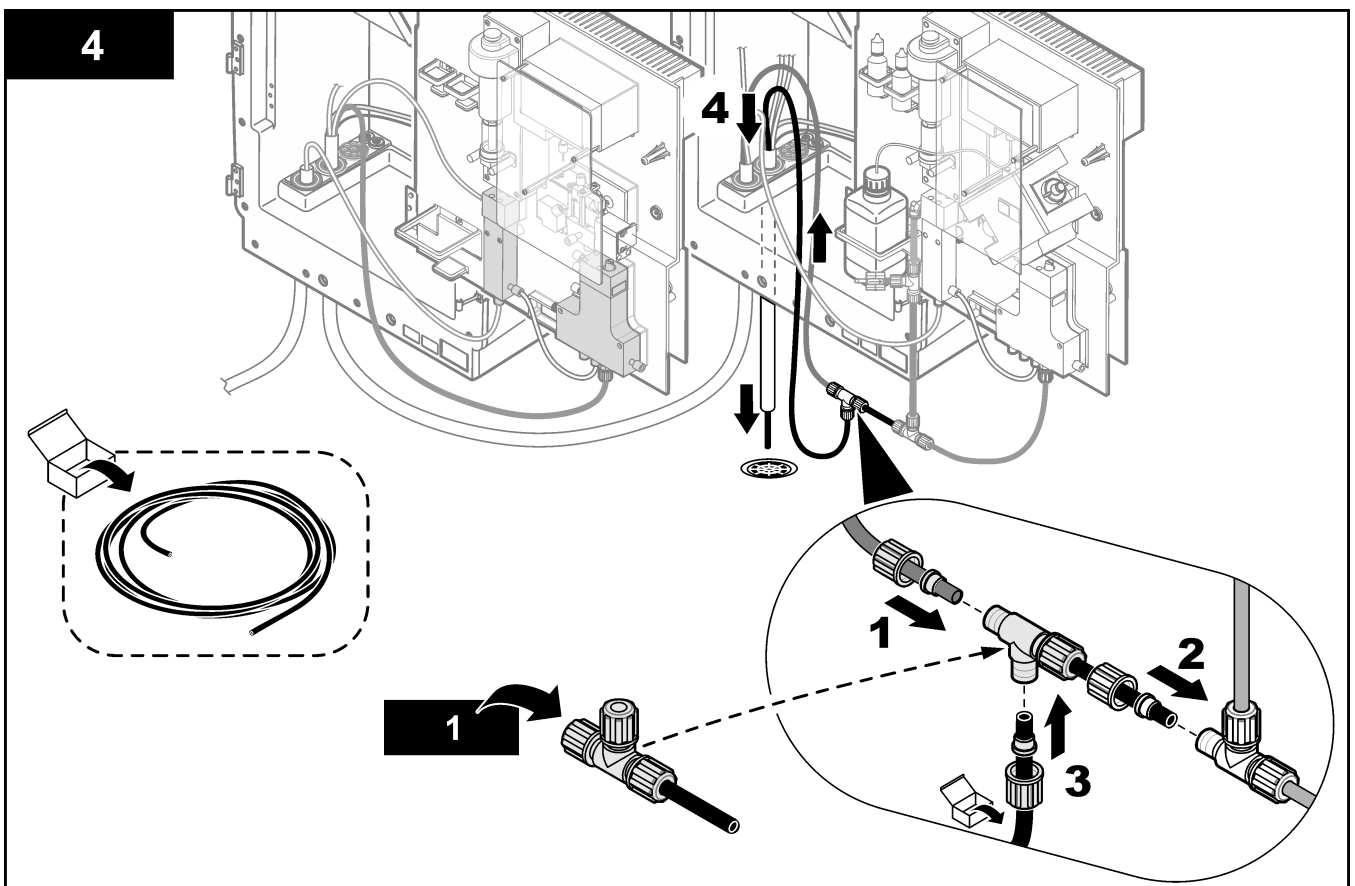
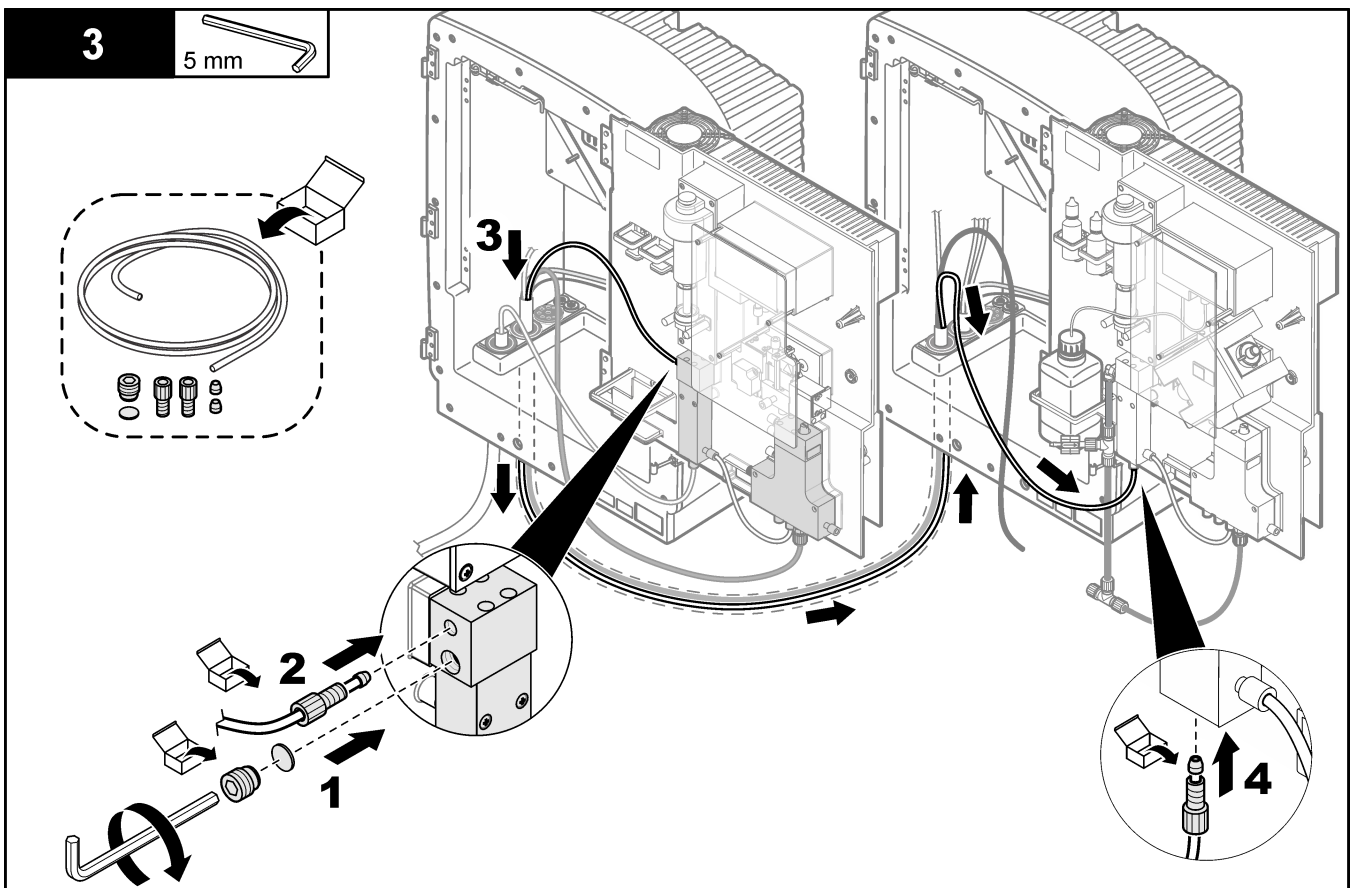



3.6 Install the collecting tray and humidity sensor

⚠ DANGER	
	Electrocution hazard. Always remove power to the instrument before making electrical connections.

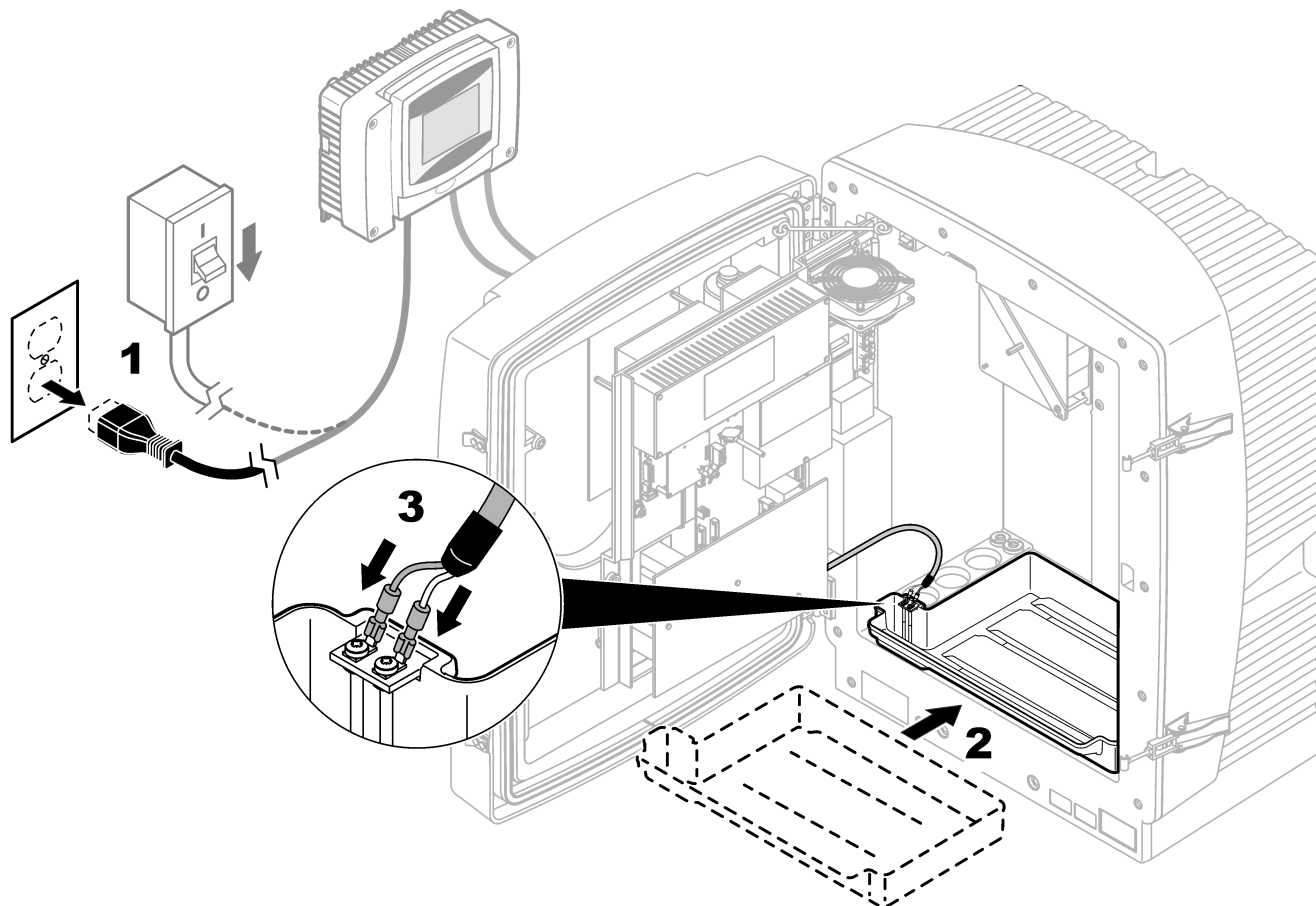
Refer to the illustrated steps that follow.



3.7 Install the reagents

⚠ WARNING	
 	Chemical exposure hazard. Obey laboratory safety procedures and wear all of the personal protective equipment appropriate to the chemicals that are handled. Refer to the current safety data sheets (MSDS/SDS) for safety protocols.

⚠ CAUTION	
	Chemical exposure hazard. Dispose of chemicals and wastes in accordance with local, regional and national regulations.

NOTICE

Carefully read the labels on the bottles to make sure that the reagents are correct or damage to the instrument can occur.

The analyzer uses four chemicals: Reagent A, Reagent B, Standard Solution S and Cleaning Solution C. The solutions are prepared at the factory and ready to install. Do the steps that follow and refer to [Figure 15](#) to install or replace the chemicals.

1. Put the reagent bottles on the collecting tray.

Note: If the bottles are replaced, make sure that the analyzer is in service mode. Refer to [Configure the maintenance settings](#) on page 41.
2. Put the correct tubing in the bottle based on the lid color. Refer to [Table 4](#).
3. Tighten the cap on the bottle.
4. Do the steps 2–3 again for each bottle.

Figure 15 Install the reagents

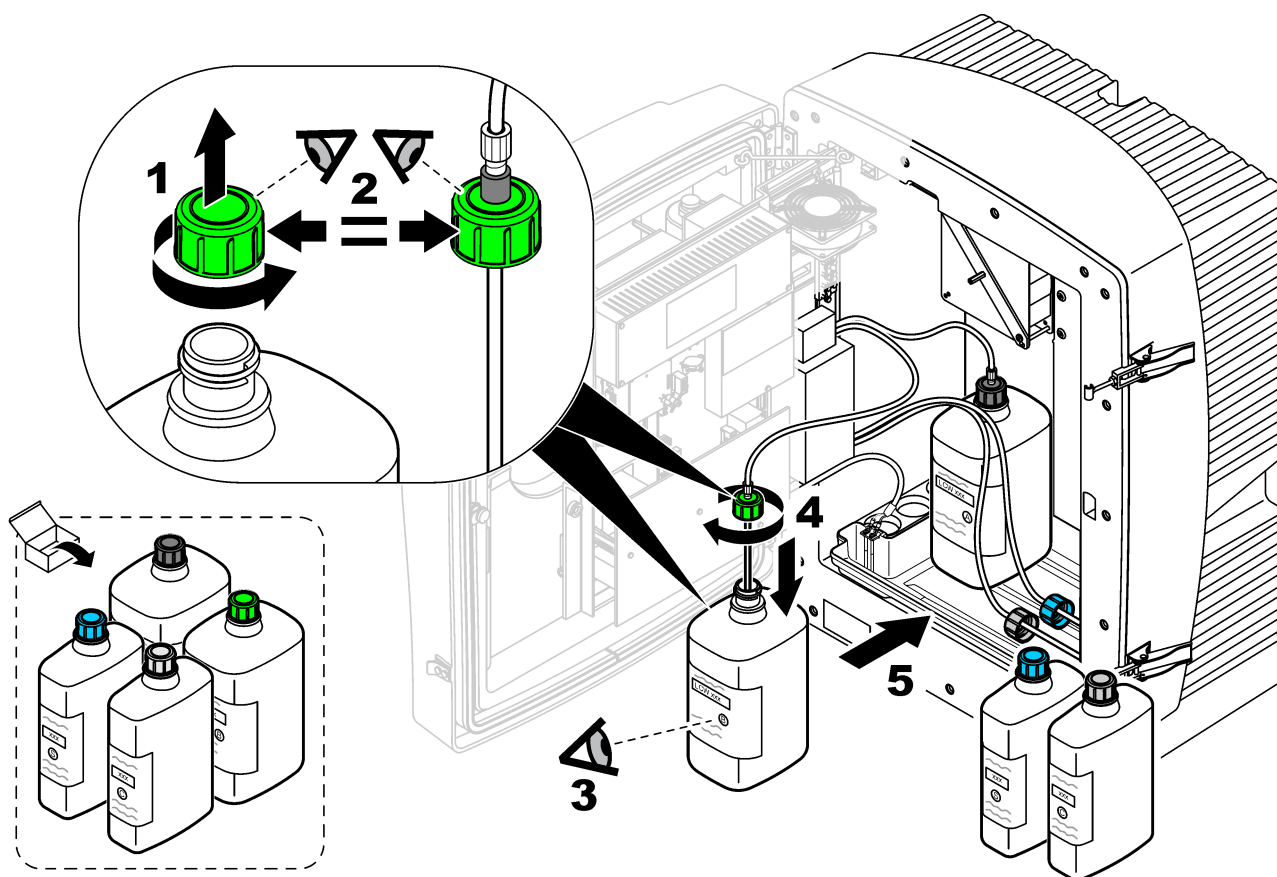

Table 4 Chemicals identification and consumption

Reagent	Lid color	Consumption	Procedure interval
Reagent A (LCW956)	Black	2000 mL in 4 months	10 minutes
Reagent B (LCW957)	Green		
Standard Solution S (LCW958)	Blue	1000 mL in 7 months	1 week
Cleaning Solution C (LCW959)	Grey		1 day

3.8 Electrical installation

3.8.1 Electrostatic discharge (ESD) considerations

NOTICE



Potential Instrument Damage. Delicate internal electronic components can be damaged by static electricity, resulting in degraded performance or eventual failure.

Refer to the steps in this procedure to prevent ESD damage to the instrument:

- Touch an earth-grounded metal surface such as the chassis of an instrument, a metal conduit or pipe to discharge static electricity from the body.
- Avoid excessive movement. Transport static-sensitive components in anti-static containers or packages.
- Wear a wrist strap connected by a wire to earth ground.
- Work in a static-safe area with anti-static floor pads and work bench pads.

3.8.2 Connect the optional heated drain

⚠ DANGER



Electrocution hazard. Always remove power to the instrument before making electrical connections.

NOTICE

The heated drain is available in 115 V and 230 V versions. Make sure that the heated drain version agrees with the local power supply.

NOTICE

The heated drain is necessary for all outdoor installations or damage to the instrument can occur.



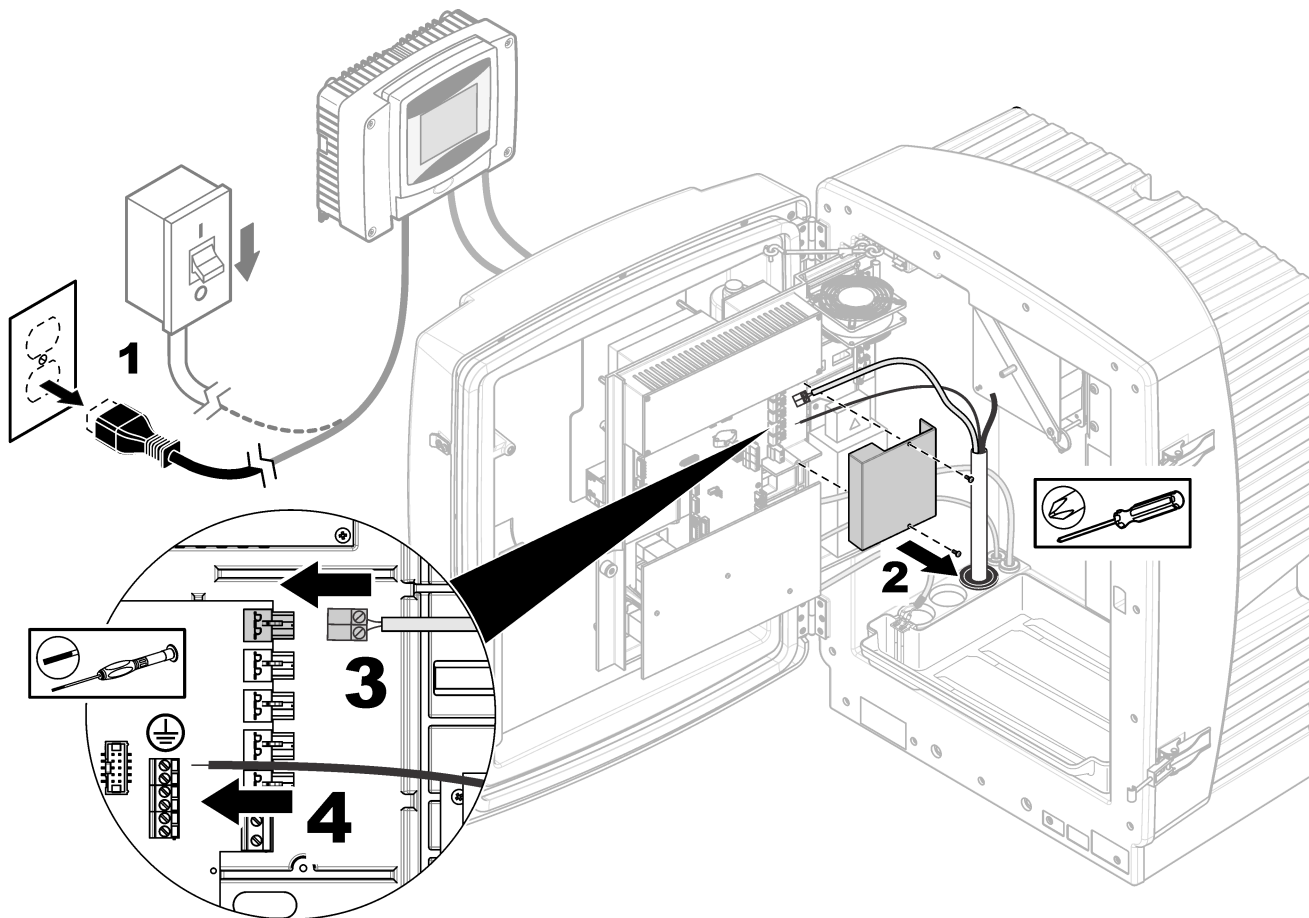

Do the steps that follow to connect the heated drain.

1. Use a tubing plug to put the heated drain hose through the analyzer access port.
2. Connect the heated drain power cable connector to the terminal block. Refer to [Figure 16](#).
3. Connect the heated earth ground wire (green/yellow) to the ground wire terminal strip.
4. Connect the drain tube based on the system configuration option. Refer to [System configuration options](#) on page 16.
5. Put the drain tube to an applicable drain or basin.
6. Install the protective cover.

Figure 16 Heated drain connections



3.8.3 Supply power to the analyzer

⚠ DANGER	
	Electrocution hazard. Protective Earth Ground (PE) connection is required.
⚠ DANGER	
	Electrical shock and fire hazards. Make sure to identify the local disconnect clearly for the conduit installation.
⚠ WARNING	
	Potential Electrocution Hazard. If this equipment is used outdoors or in potentially wet locations, a Ground Fault Interrupt device must be used for connecting the equipment to its mains power source.
⚠ WARNING	
	Electrocution hazard. The local disconnection means must disconnect all the electrical current-carrying conductors. Mains connection must keep supply polarity. The separable plug is the disconnect means for cord connected equipment.

⚠ WARNING



Electrical shock and fire hazards. Make sure that the user-supplied power cord and non-locking plug meet the applicable country code requirements.

NOTICE

Install the device in a location and position that gives easy access to the disconnect device and its operation.

NOTICE

Only connect the analyzer to the SC Controller power supply when the analyzer is fully wired internally and correctly connected to earth ground. Make sure that all of the plumbing connections, reagent installation and system start-up procedures are complete.

Supply power to the instrument with conduit or a power cable. Make sure that a circuit breaker with sufficient current capacity is installed in the power line. The circuit breaker size is based on the wire gauge used for installation.

Use an SC1000 controller or an SC200 controller in combination with an LQV155 power box to supply power to the analyzer and transmit data. Refer to the controller manual for more information.

Note: *Unless the SC Controller that connects to the analyzer is already fitted with AC mains overvoltage (surge) protection device, surge protection must be provided between the mains connection of the SC Controller and the analyzer if it is demanded by the local regulation.*

The analyzer is available in one version as 115 to 230 V wide range. The output voltage supplied by the controller at the outlets agrees to the mains voltage that is customary in the country in question and to which the controller is connected.

Note: *Do not use a 24 V controller version to supply power to the analyzer.*

1. Connect the power cable and data cable from the analyzer to the SC Controller. Refer to [Figure 17](#).

Figure 17 Connect the analyzer to the SC Controller

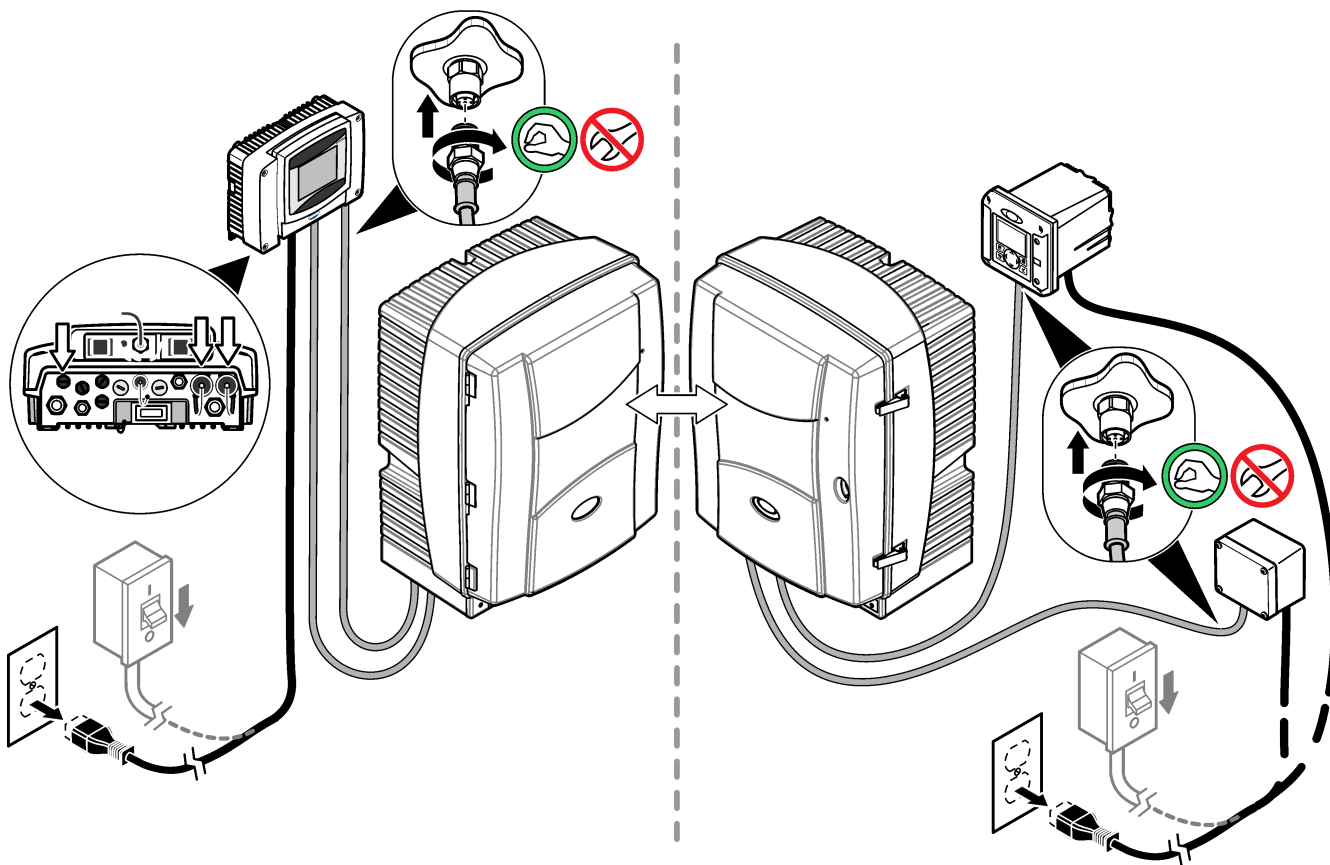

3.9 Close the analyzer

NOTICE

Close the analyzer door to keep the environmental rating of the enclosure.

NOTICE



Make sure that the lock is in the open position before closing the door or damage to the enclosure can occur.

After installation is complete, close the analytics panel and the analyzer door. Refer to [Figure 18](#).

Installation

Figure 18 Close the analyzer door

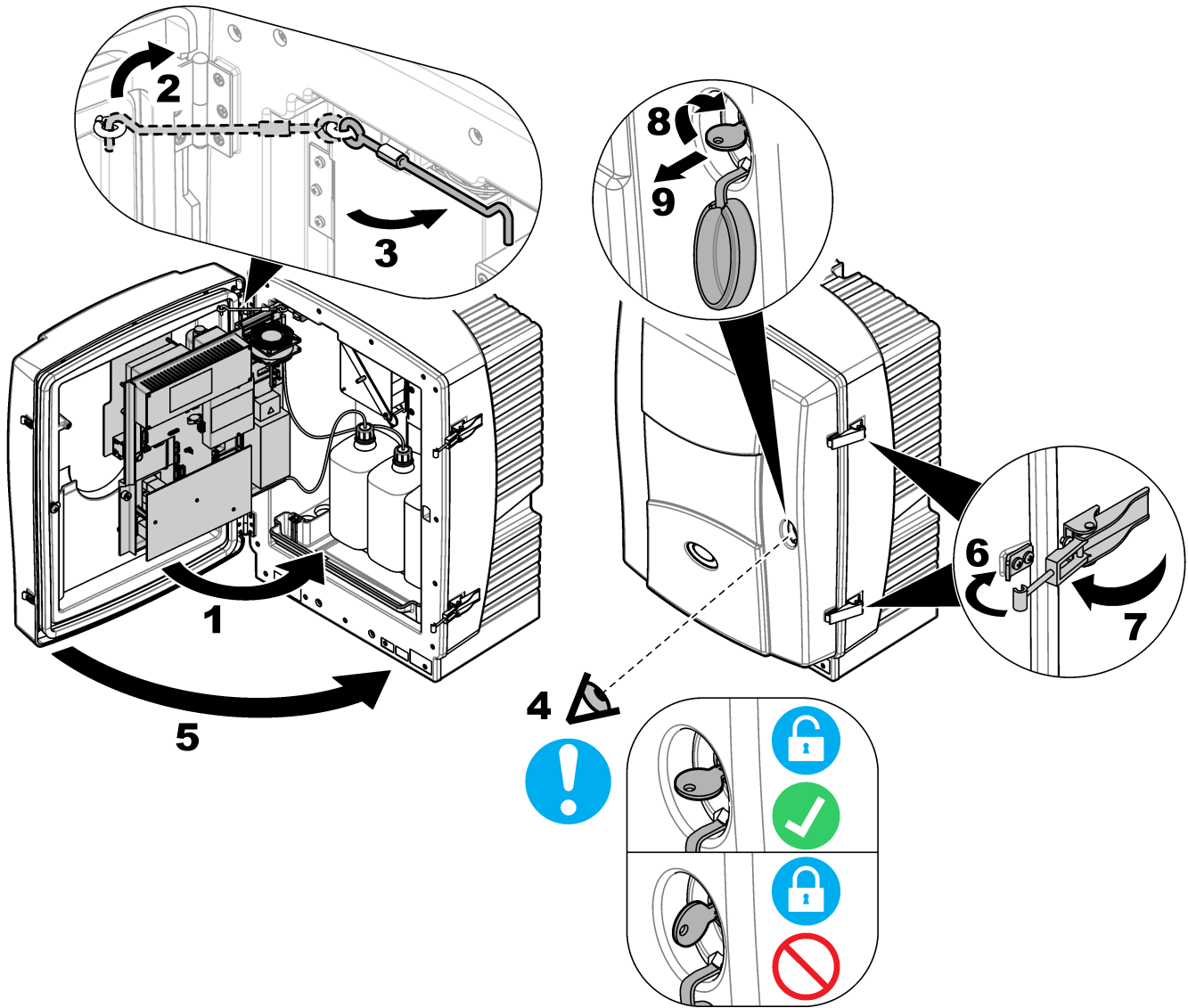

Section 4 Operation

4.1 User navigation

Note: Refer to the controller User Manual for keypad description and navigation information.

4.2 Startup

NOTICE

The internal temperature of the analyzer must be within the operating temperature. After the analyzer is energized, wait a minimum of 1 hour to let the analyzer increase the temperature to the operating temperature.

After installation is complete, do the steps that follow.

1. Make sure that the analyzer is registered in the SC Controller. Refer to the controller documentation for instructions.
2. In the SENSOR SETUP menu, select PHOSPHAX sc LR > DIAG/TEST > MAINTENANCE > SELECT PROCESS.
3. Select PREPUMP ALL.
The prepumping sequence starts.
4. Wait until prepumping is finished. The actual status is shown in the menu "PHOSPHAX sc LR > DIAG/TEST > MAINTENANCE > SIGNALS > PROCESS" on the controller display.
5. Select MEASURE from the maintenance menu.

After startup, the analyzer starts a warmup phase before the automatic measurement cycle starts. The warmup phase time is approximately 15 minutes when the analyzer temperature is more than 15 °C (59 °F).

Note: Lower analyzer temperatures increases the warmup phase.

4.3 Configure the instrument

Select the location name, measurement interval, parameter, measurement units and more.

1. Push **Menu**.
2. Select SENSOR SETUP > PHOSPHAX sc LR > CONFIGURE.
3. Select an option.

Option	Description
LOCATION	Sets the name or location of the sample source. The name or location entered shows on the measurement screen (16 characters maximum, default: serial number).
MEAS. INTERVAL	Sets the measurement interval for the analyzer. Options: 10 minutes (default), 15 minutes, 20 minutes, 30 minutes, 1 hour, 2 hours.
PARAMETER	Changes the parameters that are shown on the display and in the data log. Options: PO ₄ -P (default), PO ₄ , P ₂ O ₅ .
MEAS UNITS	Changes the measurement units that are shown on the display and in the data log. Options: mg/L (default), ppm.

Option	Description
CLEANING	Configures the automatic cleaning. The available settings are: <ul style="list-style-type: none"> • SET INTERVAL—Sets the cleaning interval for the analyzer. Options: 1, 2, 3, 6, 12, 24 hours (default), off. • START TIME—Sets the start time of the first cleaning. Options: from 00:00 (default) to 23:59. • OUTPUT MODE—Selects the output behavior during cleaning. Active: The outputs continue to agree with the operating conditions; HOLD (default)-: Keeps the outputs at the last known value; SET TRANSFER: Sets the outputs to the Set Transfer value selected in the controller settings.
DRAIN HEATING	Sets the drain heating period from "month" until "month" (default: October until April).
REMINDER	Sets the level for the reminder activation and starts applicable individual reminders (3, 7, 14, 21, 28 days, off, default: 14 days)
SET DEFAULTS	Sets the configuration to the factory defaults.

4.4 Configure the calibration settings

Select the calibration curve, calibration interval, output behavior during calibration and more.

1. Push **Menu**.
2. Select SENSOR SETUP > PHOSPHAX sc LR > CALIBRATION.
3. Select an option.

Option	Description
START	Starts a manual calibration.
FACTOR	Correction factor for the measured value (default: 1.00)
OFFSET	Sets a correction offset. Default: 0
SET INTERVAL	Sets the interval between automatic calibrations in days. Options: 2, 5, 7 (default), 14 days, off.
START TIME	Selects the start time of the calibration. From 00:00 (default) to 23:59.
OUTPUT MODE	Selects the output behavior during calibration. ACTIVE: The outputs continue to agree with the operating conditions; HOLD (default): Keeps the outputs at the last known value; SET TRANSFER: Sets the outputs to the Set Transfer value selected in the controller settings.
SET CAL DEFLT	Sets the configuration to the factory defaults.

4.5 Show analyzer data

Show analyzer information and condition to get diagnostic data.

1. Push **Menu**.
2. Select SENSOR SETUP > PHOSPHAX sc LR > DIAG/TEST.
3. Select an option.

Option	Description
SENSOR INFO	Shows the sensor name, location, serial number, sensor type, sensor range, software version and hardware version.

Option	Description
SIGNALS	Shows real-time values for the photometer, temperature, pressure and heating. In addition, shows the date of the last calibration and the actual procedure and remaining time to complete it.
COUNTERS	Shows the total time the analyzer was in operation, the actual fill rate of the reagents and the remaining days to change the air filter pads and the piston pump. <i>Note: The counters are set to zero when menu-guided maintenance is done. Refer to Configure the maintenance settings on page 41.</i>

4.6 Configure the maintenance settings

Select service mode, menu-guided maintenance, reagent counters, output behavior during maintenance and more.

1. Push **Menu**.
2. Select **SENSOR SETUP > PHOSPHAX sc LR > DIAG/TEST > MAINTENANCE**.
3. Select an option.

Option	Description
DELETE ERROR	Reset all error messages.
ACTUAL PROCESS	Shows the actual running procedure.
REMAINING TIME	Shows the remaining time to complete the current running procedure.
SELECT PROCESS	Select and start a new process: <ul style="list-style-type: none"> • SERVICE MODE • MEASURING • CALIBRATION • CLEANING • PREPUMP ALL • FLUSHING • PREPUMP REAGENT A+B • PREPUMP REAGENT A • PREPUMP REAGENT B • PREPUMP STANDARD • PREPUMP CLEANING SOL. • PREPUMP SAMPLE • VALIDATION • CHANGE AIR FILTER • CHANGE PISTON • LEAK TIGHT. AIR-P
OUTPUT MODE	Selects the output behavior during the started procedure. <ul style="list-style-type: none"> • ACTIVE—The outputs continues to agree with the operating conditions. • HOLD (default)—Keeps the outputs at the last known value. • SET TRANSFER—Sets the outputs to the Set Transfer value selected in the controller settings.
RESET COUNTERS	Sets the counters for the remaining days of the reagents, days to change the air filter pads and the syringe piston.

4.7 System configuration

Refer to the controller documentation for system configuration, general controller settings and setup for outputs and communications.

4.8 Do a measurement

After startup, the instrument starts a warmup phase before the automatic measurement cycle. Refer to [Startup](#) on page 39. An optimal measurement cycle completes in 10 minutes.

Note: Make sure that the reagent solutions are correctly installed and there are sufficient reagent solutions.

1. Select SENSOR SETUP > PHOSPHAX sc LR > CONFIGURE > MEAS.INTERVAL to configure an automatic measuring interval. Refer to [Configure the instrument](#) on page 39.
2. Select PHOSPHAX sc LR > DIAG/TEST > MAINTENANCE > SELECT PROCESS > MEASURE to start a manual measurement. Refer to [Configure the maintenance settings](#) on page 41.

4.9 Do a calibration

During calibration, the offset is calibrated with a stabilized standard solution. A calibration cycle completes in 40 minutes. When the calibration is complete, the analyzer automatically goes to measurement mode. The factory setting interval for the calibration is one time each week. Refer to [Configure the calibration settings](#) on page 40.

Note: Make sure that the standard solutions is correctly installed and there is sufficient standard solution.

1. Select PHOSPHAX sc LR > CALIBRATION > SET INTERVAL to configure an automatic calibration interval.
2. Select PHOSPHAX sc LR > CALIBRATION > START to start a manual calibration.

The calibration is postponed when the instrument was switched on for less than 1 hour, the temperature is outside of the specified range or the current measured value is > 2mg/L PO4-P.

When the calibration starts, the instrument does a self check (pump head leakage test). If the test fails, the instrument stops the calibration and shows a warning. The instrument continues to measure with the latest calibration. Before a new calibration is started, replace the pump head. Refer to [Replace the pump head for air pump \(piston pump\)](#) on page 48. Do a leakage test after the pump head replacement. Refer to [Do a leakage test](#) on page 49.

4.10 Do a clean cycle





For a correct and accurate measurement, regular cleaning of the system is necessary. During the cleaning cycle, the alkaline cleaning solution rinses all the components that touch the sample. Examine the measuring cell for precipitation and the valve block and overflow vessel for contamination. Adjust the clean cycle based on the contamination seen on the analyzer.

The analyzer completes a cleaning cycle in 10 minutes. When the cleaning cycle is complete, the analyzer automatically goes to the measuring mode.

Note: Make sure that the cleaning reagent is correctly installed and there is sufficient cleaning solution.

1. Select PHOSPHAX sc LR > CONFIGURE > CLEANING > SET INTERVAL to configure an automatic cleaning interval. Refer to [Configure the instrument](#) on page 39.
2. Select PHOSPHAX sc LR > DIAG/TEST > MAINTENANCE > SELECT PROCESS > CLEANING to start a manual cleaning cycle. Refer to [Configure the maintenance settings](#) on page 41.

Section 5 Maintenance

⚠ WARNING	
	Multiple hazards. Only qualified personnel must conduct the tasks described in this section of the document.
⚠ CAUTION	
 	Chemical exposure hazard. Obey laboratory safety procedures and wear all of the personal protective equipment appropriate to the chemicals that are handled. Refer to the current safety data sheets (MSDS/SDS) for safety protocols.
⚠ CAUTION	
	Chemical exposure hazard. Dispose of chemicals and wastes in accordance with local, regional and national regulations.

5.1 Maintenance schedule

Table 5 shows the recommended schedule of maintenance tasks. Facility requirements and operating conditions may increase the frequency of some tasks.

Table 5 Maintenance schedule

Task	3 months	6 months	1 year
Examine for damage on page 45.		X or as needed	
Examine the tubing and fittings on page 45.		X or as needed	
Clean the instrument on page 46.		X or as needed	
Clean spills on page 46.		X or as needed	
Replace the reagents on page 46.		X ⁷	
Replace the air filter pads on page 46.	X	X	
Replace the pump head for air pump (piston pump) on page 48.			X

5.2 Examine for damage

Frequently examine all of the items for damage. Replace damaged items immediately.

5.3 Examine the tubing and fittings

1. Examine all the tubing and fittings for leaks and/or damage.
2. Replace tubes with leaks or damage.
3. Tighten or replace fittings as necessary to stop leaks.
4. Examine for contamination buildup in the tubing. If contamination buildup is seen, start a cleaning cycle.

⁷ The replacement interval is dependent on the procedure interval. Refer to Table 4 on page 33.

5.4 Clean the instrument

NOTICE

Never use cleaning agents such as turpentine, acetone or similar products to clean the instrument including the display and accessories.

Clean the exterior of the instrument with a moist cloth and a mild soap solution.

5.5 Clean spills

CAUTION



Chemical exposure hazard. Dispose of chemicals and wastes in accordance with local, regional and national regulations.

1. Obey all facility safety protocols for spill control.
2. Discard the waste according to applicable regulations.

5.6 Replace the reagents

WARNING



Chemical exposure hazard. Obey laboratory safety procedures and wear all of the personal protective equipment appropriate to the chemicals that are handled. Refer to the current safety data sheets (MSDS/SDS) for safety protocols.

CAUTION



Chemical exposure hazard. Dispose of chemicals and wastes in accordance with local, regional and national regulations.

NOTICE

Carefully read the labels on the bottles to make sure that the reagents are correct or damage to the instrument can occur.

The analyzer uses four chemicals: Reagent A, Reagent B, Standard Solution S and Cleaning Solution C. Replace the reagents, standard or cleaning solution before the level in the analyzer bottles is less than 10%. Refer to [Install the reagents](#) on page 32.

After a reagent is replaced, reset the related counter. Reset the counter for Reagent B schedules a calibration which takes 40 minutes to complete.

1. Select PHOSPHAX sc LR > DIAG/TEST > MAINTENANCE > COUNTERS and push RESET.

5.7 Replace the air filter pads

WARNING



Pinch hazard. Parts that move can pinch and cause injury. Do not touch moving parts.

The analyzer has two air filter pads: the fan filter and the airflow filter. Make sure that the cooling fan is stopped before starting the filter maintenance task. Although the fan is stopped, remove the fan filter carefully to prevent injury from moving parts.

Do the steps that follow to stop the fan and replace the air filter pads:

1. Push **Menu**, then select SENSOR SETUP > PHOSPHAX sc LR.
2. Select DIAG/TEST > MAINTENANCE > SELECT PROCESS > CHANGE AIRFILTER and push **Enter**.
3. Select **START** and then push **Enter**.
The fan stops.
4. Open the analyzer enclosure and the analysis panel.
5. The analyzer goes to service mode and counts the remaining time in seconds down to zero.
6. Refer to the illustrated steps that follow to clean or replace the air filter pads and follow the instructions on the controller display.
7. Close the analyzer enclosure and the analysis panel.
8. Push **Enter**.
The instrument sets the maintenance counter to zero and stays in service mode.

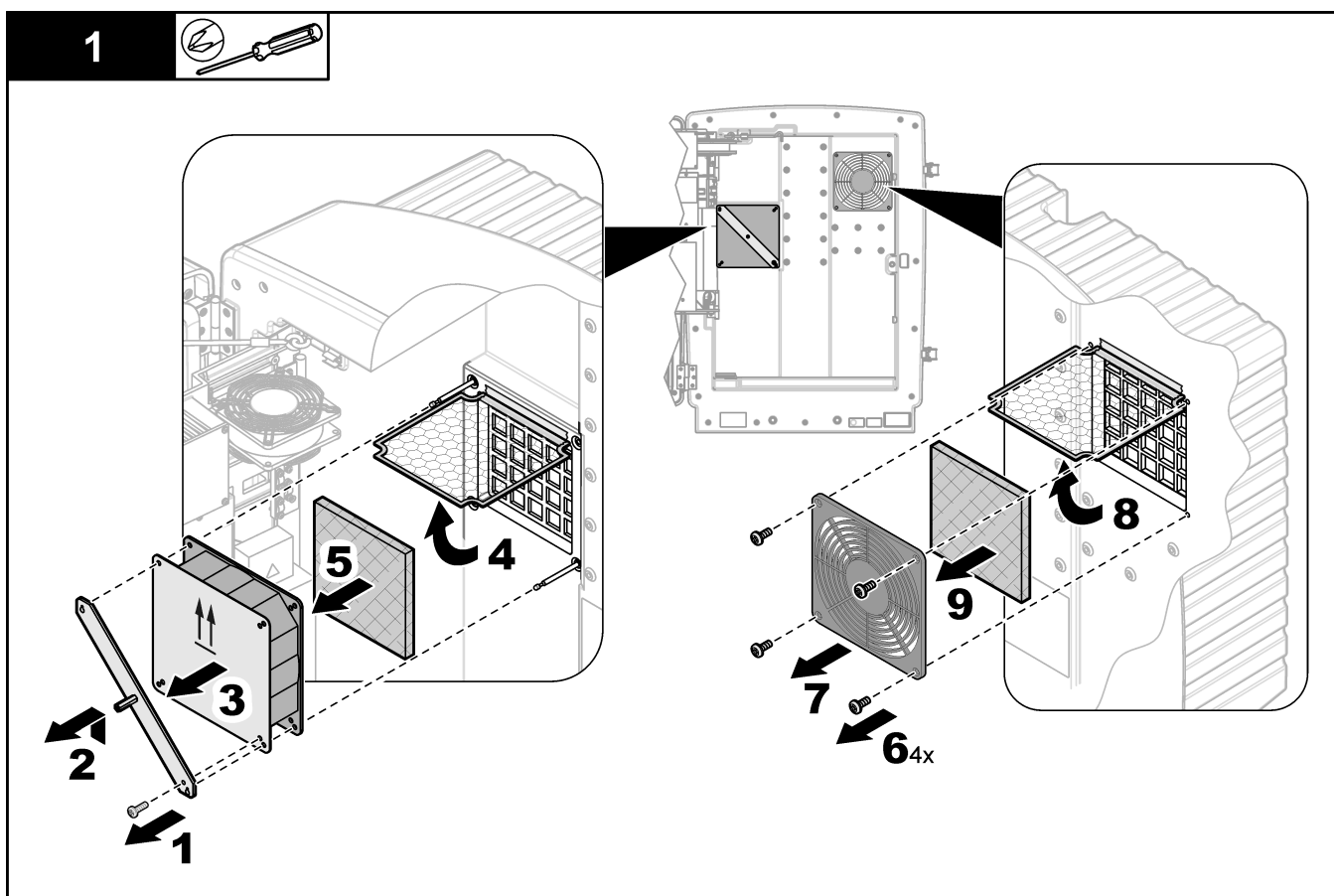

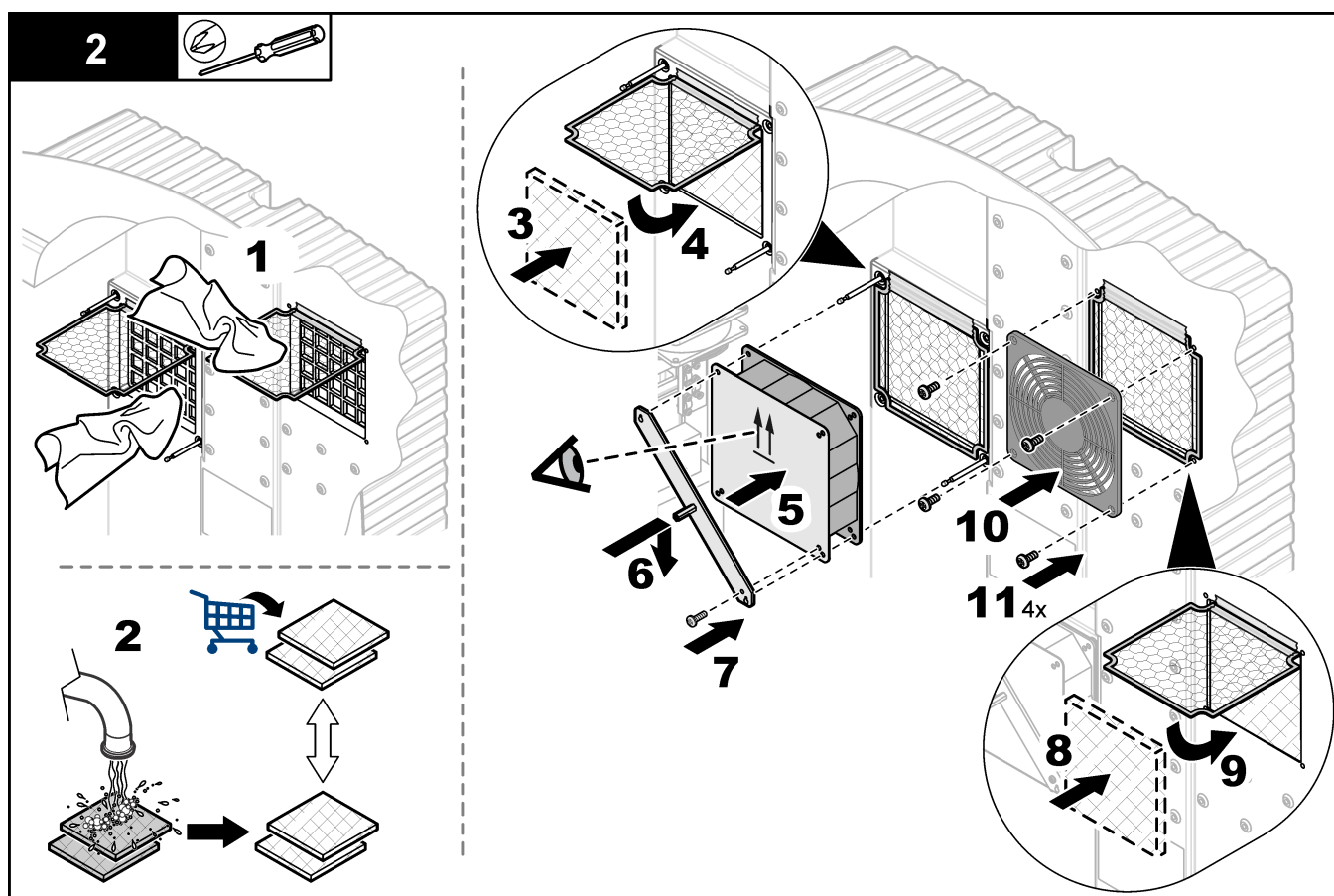

5.8 Replace the pump head for air pump (piston pump)

⚠ WARNING



Pinch hazard. Parts that move can pinch and cause injury. Do not touch moving parts.

1. Push **Menu**, then select SENSOR SETUP > PHOSPHAX sc LR.
2. Select DIAG/TEST > MAINTENANCE > SELECT PROCESS > CHANGE PISTON, then push **Enter**.
The analyzer prepares to change the piston and counts the remaining time in seconds down to zero.
3. Change the piston. Refer to the illustrated steps that follow
4. Push **Enter**.
The instrument resets the counter and enters service mode.

Figure 19 Replace piston

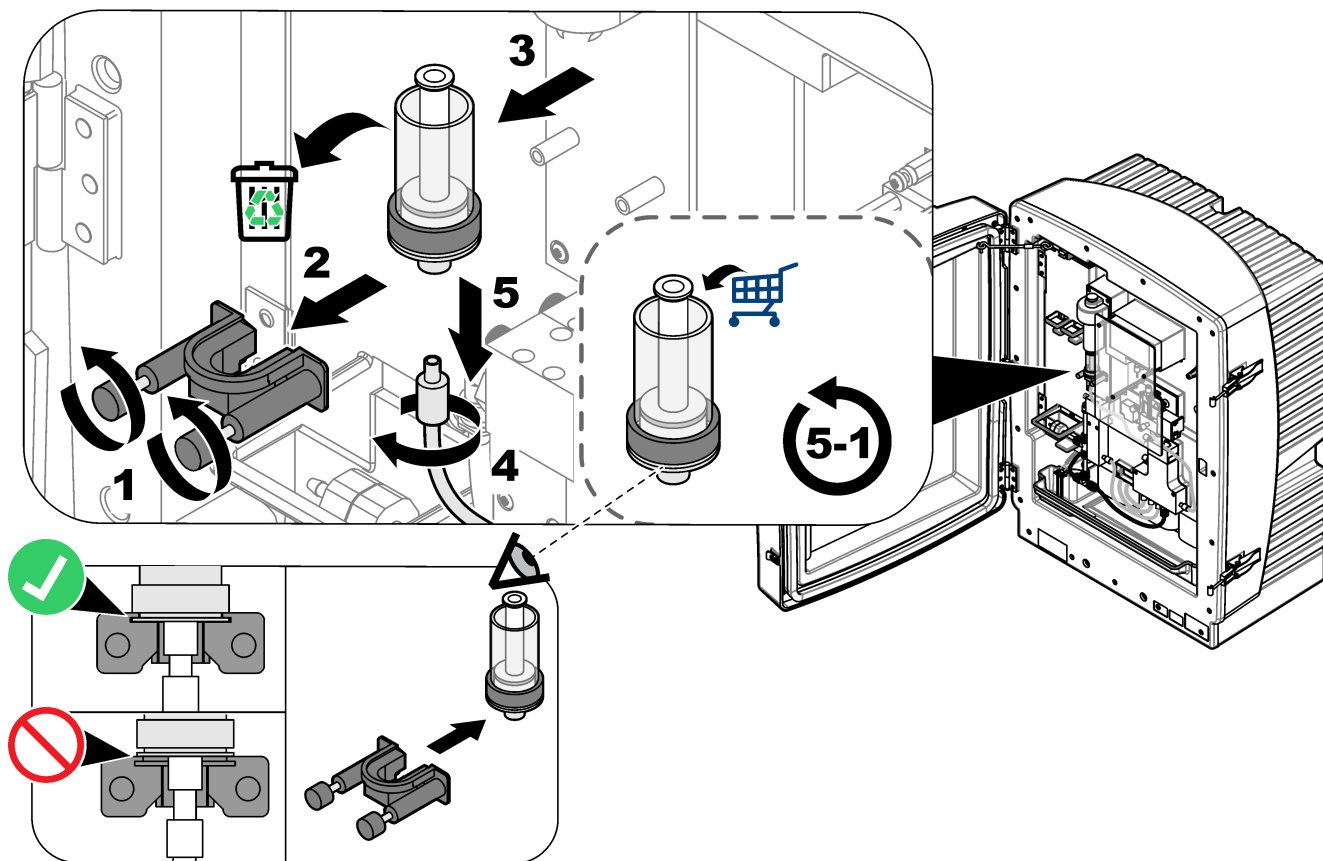

5.9 Do a leakage test

NOTICE

Do not start the measuring mode until the leakage test is complete or damage to the instrument can occur.

After the pump head replacement for the air pump, do a leakage test.

1. Push **Menu**, then select SENSOR SETUP > PHOSPHAX sc LR.
2. Select DIAG/TEST > MAINTENANCE > SELECT PROCESS > LEAK TIGHT AIR-P and push **Enter**.
The analyzer starts an automatic leakage test and counts the remaining time in seconds down to zero.

If the air pump is free of leakage, the analyzer stays in service mode and waits for the next input.

If the air pump is not free of leakage "ERROR" shows on the display. The analyzer remains in service mode and waits for the next input.

1. Repair the leakage. Refer to [Figure 19](#) on page 49. Check correct placement of the piston.
2. Do steps 1 and 2 again to check if the system has leakage.



5.10 Replace the fuses

The fuses for the power supply are found in the SC Controller. Refer to the SC Controller documentation for fuse replacement information.

5.11 Do a validation check (analytical quality assurance)

Do regular validation checks of the system to make sure that the measurement values are reliable. Usually, a validation check is done after a calibration cycle.

5.11.1 Validation with standard solution

⚠ CAUTION	
	Chemical exposure hazard. Obey laboratory safety procedures and wear all of the personal protective equipment appropriate to the chemicals that are handled. Refer to the current safety data sheets (MSDS/SDS) for safety protocols.
⚠ CAUTION	
	Chemical exposure hazard. Dispose of chemicals and wastes in accordance with local, regional and national regulations.
NOTICE	
Always put the instrument in service mode before tubing is removed. Otherwise air can get into the system and damage to the instrument could occur.	

Items to collect:



- Personal protective equipment (refer to MSDS/SDS)
 - Blind plug, LZY193 (plugging set is LZY007)
 - Beaker, 150 mL
 - Standard solution for validation
 - Fittings 3.2 mm, LZY111
1. Put the instrument in service mode. For use with Filtrax, refer to the documentation supplied.
 2. Push **Menu**.
 3. Select SENSOR SETUP > PHOSPHAX sc LR > DIAG/TEST > MAINTENANCE > SELECT PROCESS then push SERVICE MODE.
 4. On the overflow vessel, unscrew the fitting of the sample tube that connects the overflow vessel and the valve block.
 5. Screw the blind plug in the thread of the overflow vessel and put the sample tube in a 150-mL beaker with standard solution for the validation. Refer to [Figure 20](#).
Note: To have stable measurement values, put the beaker in the collecting tray and close the door of the analyzer.
 6. Push **Menu**, then select SENSOR SETUP > PSHOSPHAX sc LR.
 7. Select DIAG/TEST > MAINTENANCE > SELECT PROCESS > VALIDATION
The validation starts and the remaining time is displayed. After the validation is completed the single measurement values and the average value is shown on the display. To leave the validation screen press enter and the analyzer will enter service mode.

8. Reinstall the tube in the overflow vessel. Make sure to push the fitting into the overflow vessel as far as possible, then carefully screw the fitting into the overflow vessel.
9. Start the measurement mode or hold service mode.

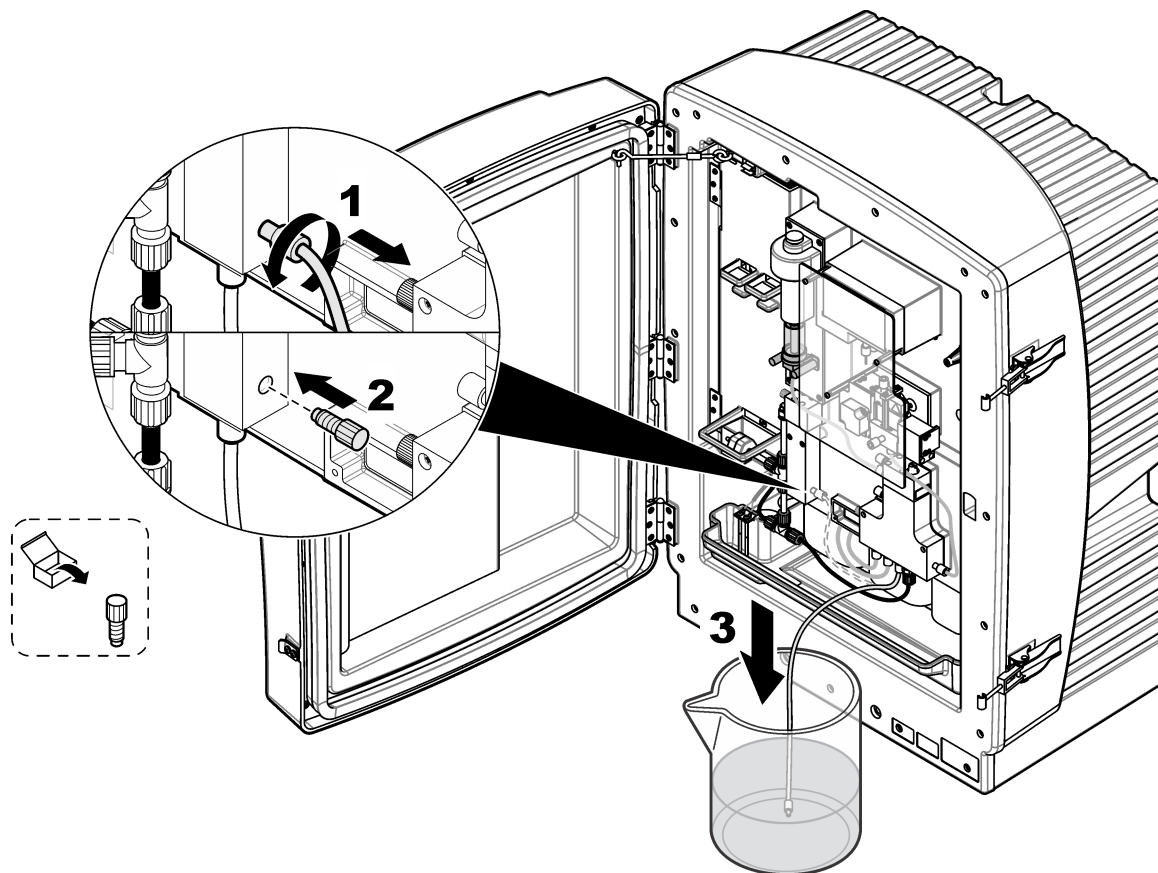
Figure 20 Prepare the analyzer for a validation check



5.11.2 Validation with applicable laboratory measurement (cuvette test)

⚠ CAUTION	
 	<p>Chemical exposure hazard. Obey laboratory safety procedures and wear all of the personal protective equipment appropriate to the chemicals that are handled. Refer to the current safety data sheets (MSDS/SDS) for safety protocols.</p>
⚠ CAUTION	
	<p>Chemical exposure hazard. Dispose of chemicals and wastes in accordance with local, regional and national regulations.</p>
NOTICE	
<p>Always put the instrument in service mode before tubing is removed. If not air can get into the system and damage to the instrument can occur.</p>	

Items to collect:

- Personal protective equipment (refer to MSDS/SDS)
 - Blind plug, LZY193 (plugging set is LZY007)
 - Beaker, 100 mL
 - Fittings 3.2 mm, LZY111
1. Stop the sample stream. For use with Filtrax, refer to the documentation supplied.
 2. Put the instrument in service mode. Push **Menu**.
 3. Select SENSOR SETUP > PHOSPHAX sc LR > DIAG/TEST > MAINTENANCE > SELECT PROCESS then push **SERVICE MODE**.
 4. Loosen the T-fitting on the overflow vessel. Refer to [Figure 21](#).
 5. Hold the beaker under the tube.
 6. Start the sample stream and exit service mode.
The instrument starts moves the sample into the beaker.
 7. Collect approximately 100 mL of sample in the beaker.
 8. Stop the sample stream and put the instrument again in service mode to stop sample movement. Refer to [3](#).
 9. Do the laboratory test. Refer to the documentation supplied with the test.
Note: Do a minimum of two laboratory measurements to compare the results.
 10. On the overflow vessel, unscrew the fitting of the sample tube that connects the overflow vessel and the valve block.
 11. Screw the blind plug in the thread of the overflow vessel and put the sample tube in the beaker. Refer to [Figure 20](#) on page 51.
Note: To have stable measurement values, put the beaker in the collecting tray and close the door of the analyzer.
 12. Install the T-fitting on the overflow vessel. Refer to [Figure 21](#) and do the steps in reverse order.
 13. The sample stream can be started for other instruments in the line.
 14. Exit service mode. Take two measurements.
 15. Select SENSOR SETUP > PHOSPHAX sc LR > DIAG/TEST > MAINTENANCE > SELECT PROCESS > SERVICE MODE and push **MEASURING**.
The instrument makes two measurements. The measurements take about 20 minutes to complete.
 16. When the measurements are complete, stop the sample stream and put the instrument to service mode.
 17. Install the tube in the overflow vessel again. Make sure to push the fitting into the overflow vessel as far as possible, then carefully screw the fitting into the overflow vessel.

Compare the two both measurements and set the factor and offset value. Refer to [Configure the calibration settings](#) on page 40.

Figure 21 Remove T-fitting

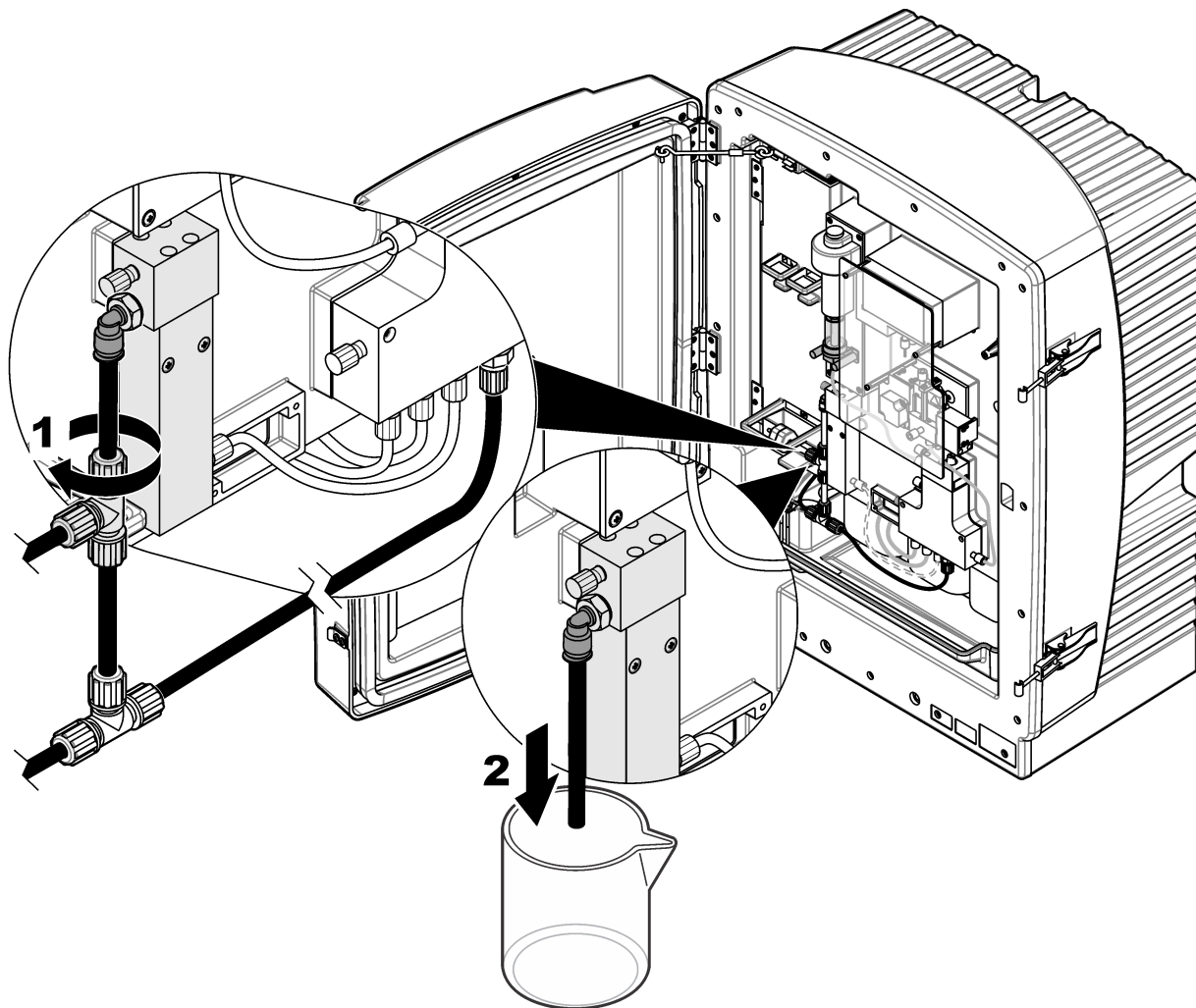

5.12 Put the analyzer in shutdown mode

No special measures are necessary to remove the analyzer from operation for a short period (a maximum of 2 days in frost-free ambient conditions).

Note: If the power supply to the controller is interrupted, frost damage may occur. Make sure that the instrument and tubing cannot freeze.

1. Stop the measurement and set the analyzer to service mode.
2. Isolate the analysis instrument from the controller.

5.12.1 Prepare the analyzer for storage

⚠ CAUTION



Chemical exposure hazard. Obey laboratory safety procedures and wear all of the personal protective equipment appropriate to the chemicals that are handled. Refer to the current safety data sheets (MSDS/SDS) for safety protocols.

Do the steps that follow to take the analyzer out of operation for an extended period (more than 2 days), or to prevent frost damage.

1. Remove the tubing from the reagent and cleaning solutions bottles and put the tubing in distilled water.
2. On the controller menu, select SENSOR SETUP > PHOSPHAX sc LR > DIAG/TEST > MAINTENANCE > SELECT PROCESS > FLUSHING to start a cleaning cycle with distilled water.
3. Clean the bottle lids with distilled water.
4. Remove the tubing out of the distilled water. Start the FLUSHING procedure to remove liquids from the analyzer.
5. Clean the bottle lids. Dry and seal the reagent bottles with the applicable bottle cap.
6. Remove the bottles from the analyzer. Keep the bottles in a frost-free location and in accordance with local regulations.
7. Install the transport lock.
8. Close the analyzer.
9. Disconnect the power and data cable from the SC Controller.
10. Remove the analyzer from the mounting hardware. Put the analyzer in a protective film or dry cloth. Keep the analyzer in a dry location.

Section 6 Troubleshooting

6.1 Troubleshoot the controller

If entries are implemented with a delay or are not accepted for a short time, the delay may be caused by a busy data network. Refer to the troubleshooting section in the controller documentation.

After a software update, a system expansion or an interruption in the power supply, it may be necessary to set the controller settings again. Record all the settings values that are changed or entered so all the necessary data can be used to configure the parameters again.

If, in usual operation, problems occur that are apparently caused by the controller, reboot the controller as follows:

1. Save all important data that is on the SC Controller.
2. Remove power from the controller. Wait 5 seconds.
3. Supply power to the controller.
4. Make sure that all of the applicable settings are correct.
5. If the problems continue, contact technical support.

6.2 Troubleshooting the analyzer

If the analyzer operation is not correct, identify if the humidity sensor has tripped. Repair the damage, dry the humidity sensor and restart the system. If the problem continues, contact technical support.

The analyzer has a status indicator light that shows different analyzer conditions, errors and warnings. Refer to [Status indicator light](#) on page 9.

Reminders

Reminders show on the controller display. To see all of the reminders, push **Menu** then select DIAGNOSTICS > PHOSPAX sc LR > REMINDER LIST.

Message	Possible cause	Solution
REAGENT A LEVEL	Level of reagent A is below the reminder level.	Examine the reagent level and replace the reagent if necessary. Refer to Replace the reagents on page 46. Then, set the reagent level counter to zero. The system can only accurately calculate the solution level if the counter is reset each time the solution is changed.
REAGENT B LEVEL	Level of reagent B is below the reminder level.	
STAND. SOLU. LEVEL	Level of standard solution is below the reminder level.	
CLEAN. SOLU. LEVEL	Level of cleaning solution is below the reminder level.	

Warnings

Warnings show on the controller display. To see all of the warnings, push **Menu** then select DIAGNOSTICS > PHOSPAX sc LR > WARNING LIST.

Message	Possible cause	Solution
WARMUP PHASE	The analyzer is in warmup phase after startup (de-frosting).	Wait until the warmup phase completes.
COOLING DOWN	The analyzer is decreasing temperature after startup.	Wait until the cooling phase completes.
ANALYZER TOO COLD	The analyzer temperature is less than 15°C (59 °F).	Identify if the heating system operation is correct. Close the analyzer door.
ANALYZER TOO WARM	The analyzer temperature is more than 55°C (131°F).	Change/clean air filter. Identify if the fan operation is correct.

Troubleshooting

Message	Possible cause	Solution
CUV TOO COOL	The cuvette temperature is too low.	Close the instrument door if it is open. Examine if the cuvette heating is working.
PHOT LEVEL LOW	The photometer signal is low.	Start a manual cleaning. If necessary, increase the cleaning interval to clean the cuvette.
SERVICE MODE	Instrument in service status.	Set the instrument back to measurement mode.
PISTON PUMP	The piston pump or tubing is not air tight. The analyzer continues to measure with the last valid calibration.	Replace the piston pump. Refer to Replace the pump head for air pump (piston pump) on page 48. Make sure to tighten all fittings.
CALIBRATION	The calibration results are not plausible or the piston pump is not air tight. The analyzer continues measuring with the last valid calibration.	Check the calibration solution level and reagent A and B level. Start a cleaning cycle several times. If the warning is not resolved, contact technical support.

Errors

Errors show on the controller display. To see all of the errors, push **Menu** then select **DIAGNOSTICS > PHOSPHAX sc LR > ERROR LIST**.

Message	Possible cause	Solution
TEMP < 0°C/32°F?	The analyzer temperature is less than 4 °C (39 °F) at startup.	Identify if the analyzer is frozen (cleaning solution, sample, reagent and/or standards). If necessary, increase the temperature of reagents and solutions. Delete the error. The analyzer will start the warmup phase to increase the system temperature.
ANALYZ. TOO COLD	The internal analyzer temperature was less than 4 °C (39 °F) for more than 5 minutes.	Identify if the heating is working. Close the analyzer door.
NO HEAT UP	It is not possible to increase the analyzer temperature to the working temperature. The internal analyzer temperature was less than 20 °C (68 °F) for more than 30 minutes.	Identify if the heating system operation is correct. Close the analyzer door.
COOLING FAILED	It is not possible to decrease the analyzer temperature to working temperature. The internal analyzer temperature is more than 57 °C (135 °F).	Change/clean air filter. Examine if the fan is working.
HUMIDITY ANALY	There is liquid in the collection tray.	Examine tubing and connections for leakage.
TEMPSSENS DEFECT	The sensor for the internal temperature is defective.	Set the instrument to off. Contact technical support.
CUVSENSOR DEFECT	The sensor for the cuvette temperature is defective.	Contact technical support.
CUVHEAT DEFECT	It is not possible to increase the cuvette temperature to the working temperature.	Identify if the heating is working. Close the analyzer door. Contact technical support.
CUV TOO HOT	The cuvette temperature is too high.	The sample is too hot. The heating system operation is not correct. Contact technical support.
PHOTO LEVEL LOW	The photometer signal is too low.	Clean cuvette. Increase the cleaning interval if necessary. Examine the sample delivery unit. Make sure that the sample inlet agrees with the sample requirements. Contact technical support.
PHOTO LEVEL HIGH	The photometer signal is too high.	Contact technical support.

Message	Possible cause	Solution
DRAIN BLOCKED	The drain line is blocked.	Clean the drain line.
SAMPLE	The amount of sample is not sufficient.	Examine the sample delivery unit. Make sure that the sample line has no negative pressure. Examine the tightness of the piston pump. Examine the overflow and air valve. Contact technical support.

Section 7 Replacement parts and accessories

⚠ WARNING



Personal injury hazard. Use of non-approved parts may cause personal injury, damage to the instrument or equipment malfunction. The replacement parts in this section are approved by the manufacturer.

Note: Product and Article numbers may vary for some selling regions. Contact the appropriate distributor or refer to the company website for contact information.

Replacement parts

Description	Item no.
Door, sc analyzer enclosure	LZY988
Door, sc analyzer enclosure (indoor)	LZY889
Door hook	LZY148
Filter pads (2 pieces)	LZY154
Collecting tray, sc analyzer	LZY146
Tubing 3.2 mm (2 m), sc analyzer	LZY195
Fittings 3.2 mm, (4 pieces)	LZY111
Fitting, tubing DN4/6	LZY134
Blind plug	LZY193
Holder, piston pump	LZY180
Pump head, air pump, 10 mL	LZY181
Fittings, 1.6 mm, (4 pieces)	LZY192
Tubing, 1.6 mm (2 m), sc analyzer	LZY194
Air filter	LZY493
Check valve	LZY470
T-fitting	LZY133
Valve block	LXZ442.99.00012

Accessories

Description	Item no.
Kit for two-parameter configuration	LZY189
Cutter for tubing	LZY201
Heated drain hose, 230 V	LZY302
Heated drain hose, 115 V	LZY303
Connectors, sc analyzers	LZY190

Mounting hardware

Description	Item no.
Mounting kit, sc analyzer, with fastening, angle bracket and screws	LZY044
Rail mounting, analyzer with controller	LZY285
Rail mounting, analyzer without controller	LZY316

Replacement parts and accessories

Mounting hardware (continued)

Description	Item no.
Stand mounting, sc analyzer with controller	LZY286
Stand mounting, sc analyzer without controller	LZY287

Reagents and standard solutions

Description	Item no.
Reagent Set A/B (contains LCW956 + LCW957)	LCW955
Reagent A	LCW956
Reagent B	LCW957
Standard Solution S	LCW958
Cleaning Solution C	LCW959

HACH COMPANY World Headquarters

P.O. Box 389, Loveland, CO 80539-0389 U.S.A.
Tel. (970) 669-3050
(800) 227-4224 (U.S.A. only)
Fax (970) 669-2932
orders@hach.com
www.hach.com

HACH LANGE GMBH

Willstätterstraße 11
D-40549 Düsseldorf, Germany
Tel. +49 (0) 2 11 52 88-320
Fax +49 (0) 2 11 52 88-210
info-de@hach.com
www.de.hach.com

HACH LANGE Sàrl

6, route de Compois
1222 Vézenaz
SWITZERLAND
Tel. +41 22 594 6400
Fax +41 22 594 6499

