



DOC022.53.80027

ISENA381

05/2026, Edition 6

User Manual

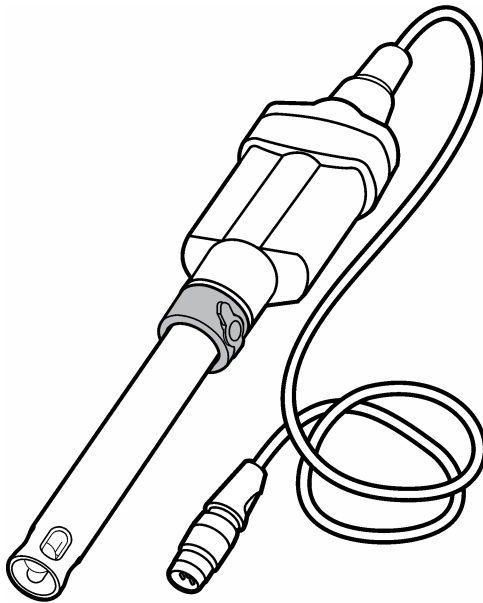

Section 1 Product overview	3
Section 2 Specifications	3
Section 3 Safety information	4
3.1 Intended use	4
3.2 Use of hazard information	4
3.3 Precautionary labels	4
3.4 Product hazards	5
Section 4 Preparation for use	5
Section 5 Calibration	7
5.1 Calibration notes	7
5.2 Calibration procedure	8
Section 6 Sample measurement	9
6.1 Sample measurement notes	9
6.2 Sample measurement procedure	9
6.3 Interferences	10
Section 7 Verify the calibration	10
7.1 Verification procedure	11
Section 8 Maintenance	11
8.1 Clean the probe	12
8.2 Fill the probe	12
8.3 Replace the filling solution	13
8.4 Storage	13
Section 9 Troubleshooting	14
9.1 Slope check	15
9.2 Standard additions check	15
Section 10 Consumables	16
10.1 Accessories	16

Section 1 Product overview

The Intellical ISENA381 series probes are digital, combination ion-selective electrodes (ISE) that measure the concentration of sodium in wastewater, drinking water and general water samples. The probes are refillable and have a built-in temperature sensor and a double ceramic pin for a reference junction. A 59-mL bottle of electrode filling solution is supplied with the probe. Refer to [Figure 1](#).

Figure 1 Probe overview

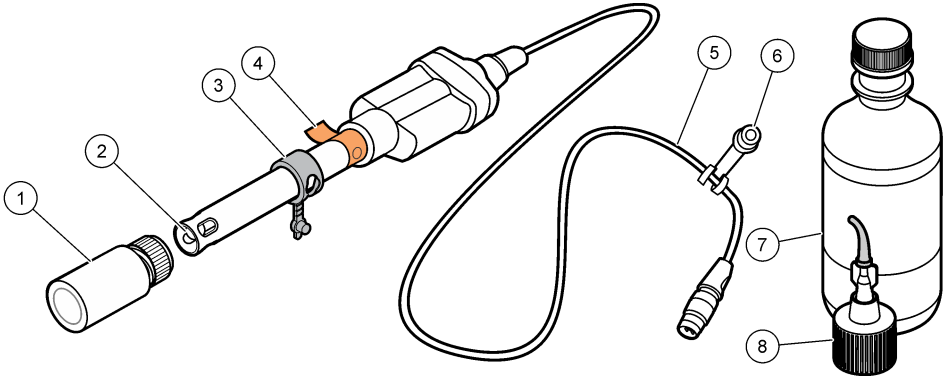

1 Probe soaker bottle with storage solution	5 Cable
2 Glass bulb, reference junction and temperature sensor	6 Probe soaker bottle holder
3 Filling-hole plug	7 Electrode filling and storage solution
4 Protective tape and filling hole	8 Dispensing cap

Section 2 Specifications

Specifications are subject to change without notice.

Specifications	Details
Probe type	Digital, combination ion selective probe with a double junction, refillable junction reference and a built-in temperature sensor
Measurement range	0.023 mg/L (1×10^{-6} M) to 23,000 mg/L (1 M) Na ⁺
Accuracy	± 0.02 mV or 0.05% (the larger value)
Electrode resistance	< 800 M Ω at 25 °C (77 °F)
Reference type	Ag/AgCl
Reference junction	Double ceramic porous pin junction
Slope	-59 mV/pNa (90 to 110% at 25 °C (77 °F) per Nernstian theoretical value)
Linear region	1.4 mg/L to 23,000 mg/L Na ⁺
Temperature accuracy	± 0.3 °C (± 0.54 °F)
Temperature sensor type	30 k Ω NTC thermistor
Operating temperature	0 to 50 °C (32 to 122 °F)
Storage temperature	5 to 40 °C (41 to 104 °F)
Response time in linear region	1 to 2 minutes in sample concentration > 1.4 mg/L

Specifications	Details
Minimum sample volume	25 mL
Minimum immersion depth	25.4 mm (1 in.)
Electrode filling solution	0.02 M NH ₄ Cl
Storage solution	Long-term storage: 0.02 M NH ₄ Cl Short-term storage: User-prepared solution of 100-mg/L sodium standard solution and one sodium ISA powder pillow per 25 mL
Sensor material	pH glass
Cable connection	M12 digital output and connector
Dimensions	Diameter: 12 mm (0.47 in.) Length: 175 mm (6.9 in.) total; 103 mm (4.1 in.) below head Cable length: ISENA38101: 1 m (3.3 ft); ISENA38103: 3 m (9.8 ft)
Warranty	1 year on the probe. This warranty covers manufacturing defects, but not improper use or wear.
Certifications	CE, FCC/ISED

Section 3 Safety information

3.1 Intended use

The Intellical probes are intended for use by individuals who measure water quality parameters in the laboratory. The Intellical probes do not treat or alter water.

3.2 Use of hazard information

DANGER

Indicates a potentially or imminently hazardous situation which, if not avoided, will result in death or serious injury.

WARNING

Indicates a potentially or imminently hazardous situation which, if not avoided, could result in death or serious injury.

CAUTION

Indicates a potentially hazardous situation that may result in minor or moderate injury.

NOTICE

Indicates a situation which, if not avoided, may cause damage to the instrument. Information that requires special emphasis.

3.3 Precautionary labels

Read all labels and tags attached to the instrument. Personal injury or damage to the instrument could occur if not observed. A symbol on the instrument is referenced in the manual with a precautionary statement.

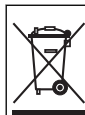

Electrical equipment marked with this symbol may not be disposed of in European domestic or public disposal systems. Return old or end-of-life equipment to the manufacturer for disposal at no charge to the user.

3.4 Product hazards

▲ CAUTION



Chemical exposure hazard. Obey laboratory safety procedures and wear all of the personal protective equipment appropriate to the chemicals that are handled. Refer to the current safety data sheets (MSDS/SDS) for safety protocols.

▲ CAUTION



Chemical exposure hazard. Dispose of chemicals and wastes in accordance with local, regional and national regulations.

▲ CAUTION



Personal injury hazard. Glass components can break. Handle with care to prevent cuts.

Section 4 Preparation for use

NOTICE

Make sure to remove the protective tape from the filling hole of new probes. A probe with a blocked filling hole will not operate correctly.

New probes are filled with electrolyte filling solution and have a soaker bottle that contains storage solution to keep the glass bulb and reference junction hydrated. Prepare the probe for calibration and measurement as follows.

1. Prepare the sodium (ISA) rinse solution as follows:
 - a. Pour a minimum of 25 mL of deionized water into a wash bottle.
 - b. Add one sodium ISA powder pillow (0.4 g) for each 25 mL of deionized water and mix. For example, to prepare 200 mL of sodium ISA rinse solution, refer to [Figure 2](#).
2. Remove the protective tape from the filling hole. Refer to [Figure 3](#).
3. Rinse the reference junction and glass bulb with the prepared sodium ISA rinse solution. Blot dry with a lint-free cloth. Do not use deionized water.
4. If the inner filling solution is low, add more filling solution. Refer to [Fill the probe](#) on page 12.
5. Condition the probe as follows:
 - a. Dissolve one Sodium Ionic Strength Adjustor (ISA) Powder Pillow in 25 mL of a 100 mg/L sodium standard solution.
 - b. Open the filling hole.
 - c. Put the probe in the prepared solution and soak the probe for 1 hour or more (8 hours for best results).

Note: If probe stabilization is slow after storage, condition the probe for 1 hour or more (8 hours for best results) in 25 mL of a 100 mg/L sodium standard solution that contains one Sodium Ionic Strength Adjustor (ISA) Powder Pillow.
6. Make sure that the meter has the correct date and time settings. The service-life time stamp in the probe comes from the date and time settings in the meter.

Note: Some meters automatically open the date and time settings when the meter starts for the first time, or after battery replacement.
7. Connect the probe to the meter.
8. Open the filling hole before use. Keep the level of the electrolyte filling solution above the level of the measurement liquid during use. Refer to [Figure 4](#).

Figure 2 Prepare 200 mL sodium ISA rinse solution

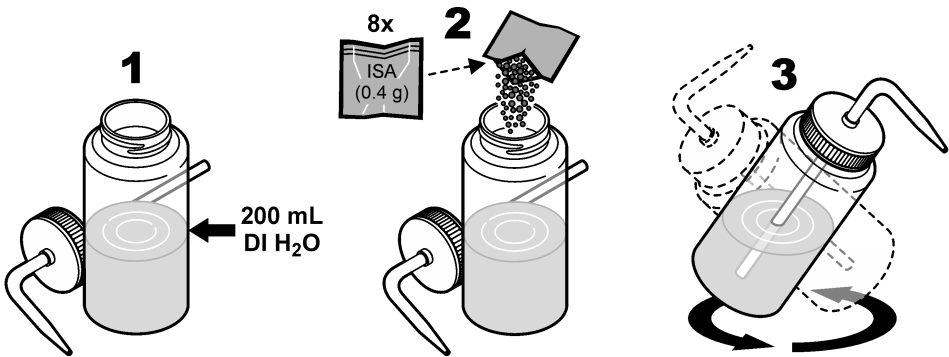

Figure 3 Remove the protective tape

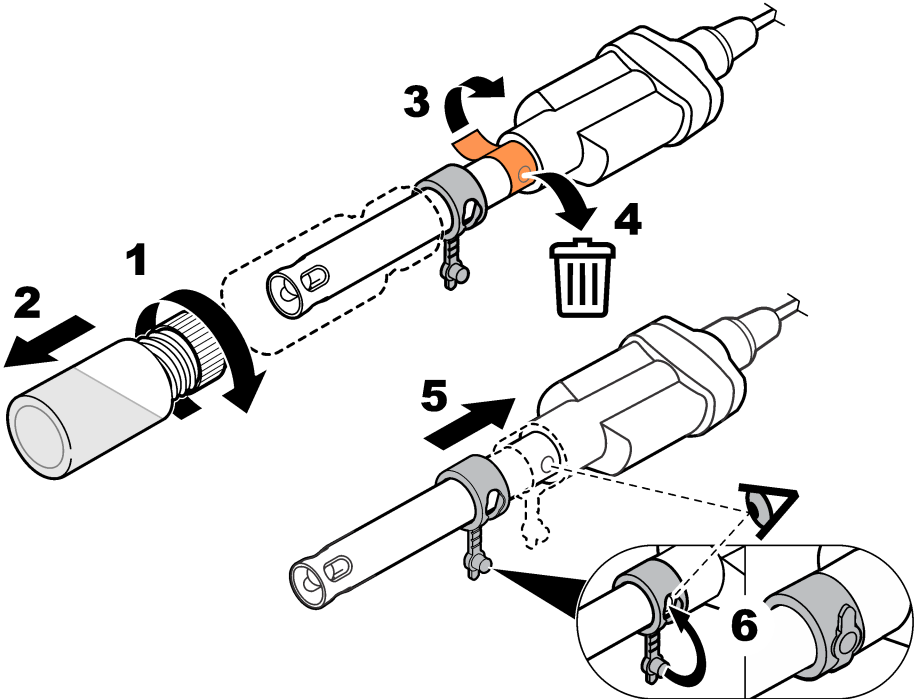
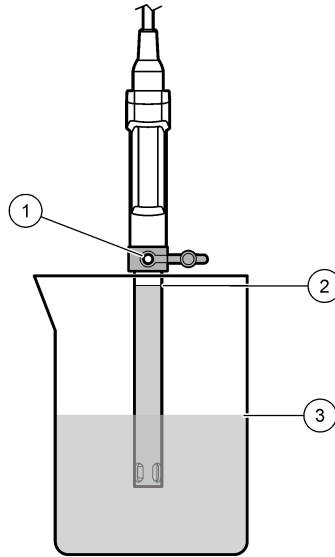

Figure 4 Probe position during use



1 Filling hole in open position	3 Level of calibration solution or sample
2 Level of electrolyte filling solution	

Section 5 Calibration

The procedure that follows is applicable to meters that can connect to Intellical ISE probes. Refer to the applicable meter documentation for meter operation and probe-specific settings.

5.1 Calibration notes

Read the notes that follow before calibration.

- Use only the prepared sodium ISA rinse solution to rinse the probe. Refer to [Preparation for use](#) on page 5.
- For calibrations with low-level standards (<1 mg/L), use plastic beakers.
- Measure the standard solutions from lowest to highest concentration for best results.
- Keep all of the solutions (standard solutions and samples) at the same temperature ($\pm 2\text{ }^{\circ}\text{C}$ ($\pm 3.6\text{ }^{\circ}\text{F}$)) for best results.
- Stir the standards and samples at a slow and constant rate to prevent the formation of a vortex.
- Use the default calibration options or change the options in the probe settings menu.
- Use the single display mode for calibration when more than one probe is connected to the meter (if applicable).
- Calibrate the probes and verify the calibration regularly for best results. Use the meter to set calibration reminders.
- The calibration data is stored in the probe. When a calibrated probe is connected to a different meter with the same calibration options, a new calibration is not necessary.
- Air bubbles below the sensor when in solution can cause a slow response or error in the calibration. Make sure to remove air bubbles during calibration.

5.2 Calibration procedure

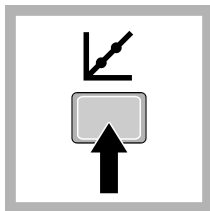

1. Go to the calibrate menu. Select the probe, if applicable. The display shows the standard solutions to use for calibration.

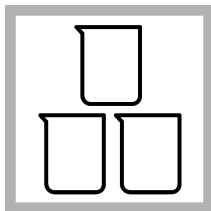

2. Add 25 mL of each standard solution to different beakers.

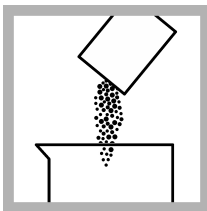

3. Add one Sodium Ionic Strength Adjustor (ISA) Powder Pillow to each 25 mL of standard solution.



4. Add a stir bar to the first standard solution. Put the standard solution on an electromagnetic stirrer. Stir at a moderate rate.

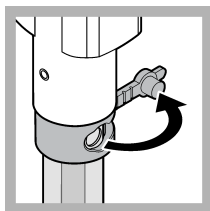

5. Open the filling hole.



6. Rinse the probe with the prepared sodium ISA rinse solution. Dry the probe with a lint-free cloth. **Do not use deionized water.**

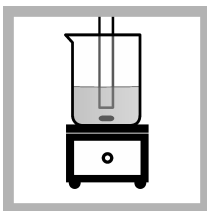

7. Put the probe in the standard solution with the sensor fully submerged. Do not put the probe on the bottom or sides of the beaker.

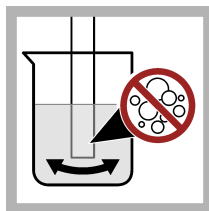

8. Shake the probe from side to side to remove air bubbles.

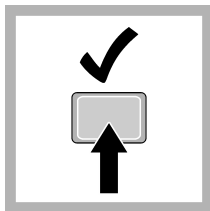

9. Stir for 30 to 60 seconds, then read the sodium concentration of the standard solution.

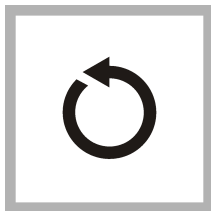

10. Do steps 3 through 9 to read the value of the remaining standard solutions.

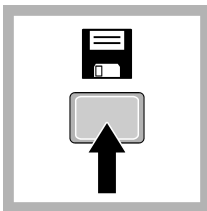

11. Save the calibration.

Section 6 Sample measurement

The procedure that follows is applicable to meters that can connect to Intellical ISE probes. Refer to the applicable meter documentation for meter operation and probe-specific settings.

6.1 Sample measurement notes

Read the notes that follow before sample measurements.

- Rinse the probe with the prepared sodium ISA rinse solution and dry with a lint-free cloth between measurements to prevent contamination. Use only the prepared sodium ISA rinse solution to rinse the probe. Refer to [Preparation for use](#) on page 5.
- For measurements below 1 mg/L, use plastic beakers.
- If the stabilization time is long, try a different stir rate and make sure to condition the probe. Use a standard solution (with ISA) that is near in concentration to the samples to be measured.
- Keep all of the solutions (standard solutions and samples) at the same temperature ($\pm 2\text{ }^{\circ}\text{C}$ ($\pm 3.6\text{ }^{\circ}\text{F}$)) for best results.
- If complete traceability is necessary, enter a sample ID and operator ID before measurement. Refer to the meter manual for instructions.
- Stir the standards and samples at a slow and constant rate to prevent the formation of a vortex.
- The meter automatically saves the measurement data when the user manually reads each data point and when the meter is set to read at regular intervals. The user must manually save each data point when the meter is set to read continuously.
- Air bubbles below the sensor can cause a slow response or error in the measurement. Make sure to remove air bubbles before and during measurements.

6.2 Sample measurement procedure



1. Pour 25 mL of fresh sample into a 50-mL beaker.

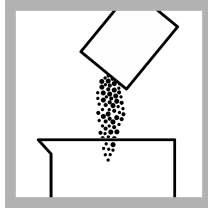

2. Add one Sodium Ionic Strength Adjustor (ISA) Powder Pillow.

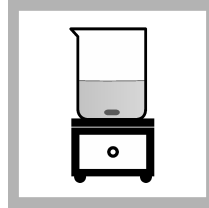

3. Add a stir bar. Put the beaker on an electromagnetic stirrer. Stir at a moderate rate.

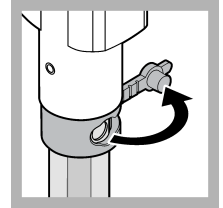

4. Open the filling hole.



5. Rinse the probe with the prepared sodium ISA rinse solution. Dry the probe with a lint-free cloth. **Do not use deionized water.**

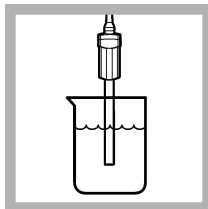

6. Put the probe in the sample with the sensor fully in the sample. Do not put the probe on the bottom or sides of the beaker.

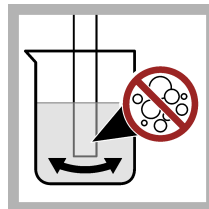

7. Shake the probe from side to side to refresh the reference junction and remove air bubbles.

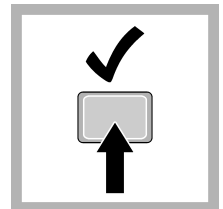

8. Stir for 30 to 60 seconds, then read the sodium concentration of the sample. The display shows the value when the reading is stable.

6.3 Interferences

The sensing element will measure some other ions that are known to interfere with the method. The probe response to other ions usually increases the mV potential and causes a positive error. The response to other ions can be semi-quantitatively calculated through the Nikolsky equation, an extended Nernst equation:

$$E = E^{\circ} + (RT/(zF))\ln[aN_a + KN_a x \times ax]$$

Where

- ax = the activity of the interfering ion
- $KN_a x$ = the selectivity coefficient for the interfering ion relative to the primary ion

The primary interferences for sodium ion-selective electrodes are silver and hydrogen ions. The sodium ISA increases the pH, which decreases interference from the hydrogen ion. If the sample contains high levels of interferences, soak the probe in 1 M sodium chloride to remove the ions from the glass membrane.

If the samples are very acidic or have a high buffer capacity, make sure that the sample pH is above 9 after the ISA is added. If necessary, add a known quantity of ammonium hydroxide (NH_4OH) to the calibration standards and the samples to increase the pH. The ammonium ion NH_4^+ has a low selectivity coefficient and does not interfere.

The ions that interfere in sodium determinations are given for molar concentrations of all ions. The smaller the value of the selectivity coefficient, the lower the interference. Approximate values of selectivity coefficients (K) are ordered from highest to lowest in [Table 1](#).

Table 1 Interferences

Interference	Selectivity coefficient
Silver (Ag^+)	>1000
Hydrogen ion (H^+)	20 (reduced by ISA addition)
Lithium (Li^+)	0.01
Potassium (K^+)	0.001
Thallium (Tl^+)	0.0002

Section 7 Verify the calibration

Measure the value of a fresh standard solution at regular intervals to make sure the result is accurate. The meter compares the expected standard solution value to the measured value and accepts or rejects the measurement. The user can change the standard solution and acceptance criteria for verification in the probe-specific settings.

Note: Password protection may prevent access to the acceptance criteria.

7.1 Verification procedure

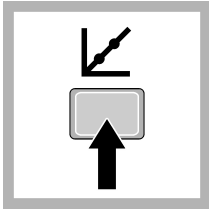

1. Go to the verification menu. The display shows the standard solution to use for verification.

Note: Menu name for HQd meters: Run check standard.

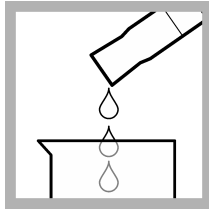

2. Pour 25 mL of the standard solution into a 50-mL beaker.

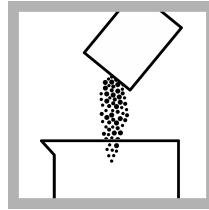

3. Add one Sodium Ionic Strength Adjustor (ISA) Powder Pillow.



4. Add a stir bar. Put the beaker on an electromagnetic stirrer. Stir at a moderate rate.

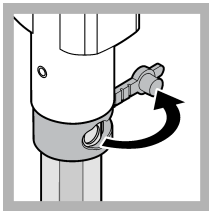

5. Open the filling hole.

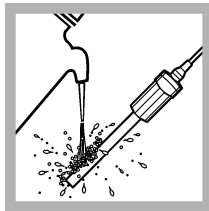

6. Rinse the probe with the prepared sodium ISA rinse solution. Dry the probe with a lint-free cloth. **Do not use deionized water.**

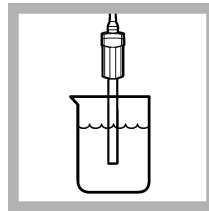

7. Put the probe in the standard solution with the sensor fully in the solution. Do not put the probe on the bottom or sides of the beaker.

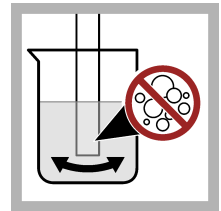

8. Shake the probe from side to side to remove air bubbles.

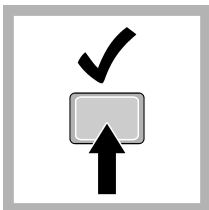

9. Stir for 30 to 60 seconds, then read the value of the standard solution. The meter accepts or rejects the result.

Section 8 Maintenance

Regular maintenance is necessary for the best accuracy, stabilization time and life of the probe. Keep the probe in the recommended storage solution between measurements.

8.1 Clean the probe

Clean the probe regularly to remove mineral or sample buildup on the sensing element. Symptoms of contamination:

- Incorrect or irregular readings
- Slow stabilization times
- Calibration errors
- Sample material stays on the probe

1. Rinse the probe with the prepared sodium ISA rinse solution. Dry the probe with a lint-free cloth. Do not use deionized water.
2. Soak the glass bulb for 12 to 16 hours in Hach Electrode Cleaning Solution.
3. Soak the probe for 1 minute in 25 mL of a 100-mg/L sodium standard solution that contains one Sodium Ionic Strength Adjustor (ISA) Powder Pillow.
4. Rinse the probe with tap water, then rinse with the prepared sodium ISA rinse solution.

8.2 Fill the probe

Add electrolyte filling solution to the probe regularly to make sure that the electrolyte flows from the probe to the sample. Refer to [Figure 5](#). Refer to [Specifications](#) on page 3 for the correct filling solution.

Note: If the dispensing tip becomes clogged, remove the dispensing tip and soak the tip in warm ISA rinse solution. Fully dry and assemble the tip.

Figure 5 Fill the probe

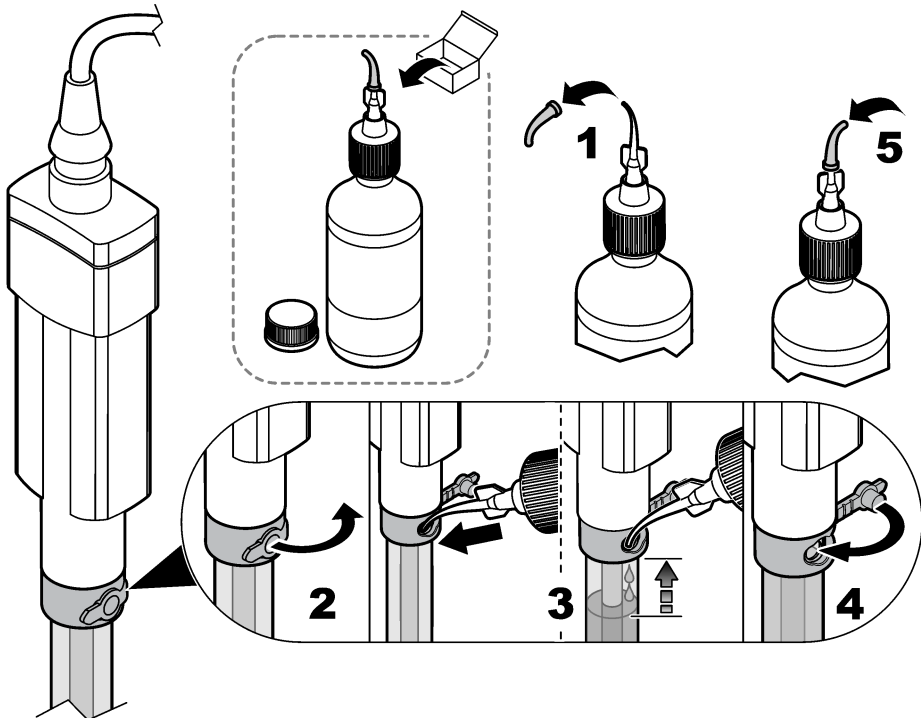

8.3 Replace the filling solution

If the filling solution becomes contaminated, replace the filling solution.

1. Tilt the probe and open the filling hole.
2. Use a plastic transfer pipet to remove the contaminated solution from the filling hole. Discard the solution.
3. Rinse the inner probe three times with deionized water.
4. Rinse the inner probe three times with new filling solution.
5. Fill the probe with new filling solution. Refer to [Fill the probe](#) on page 12.

8.4 Storage

NOTICE

Probes can become permanently damaged if kept in a storage solution that is not specified by the manufacturer. Use only the specified storage solution.

For short-term storage (24 hours or less), the probe can stay in a solution of 100 mg/L Na⁺ standard solution with one Sodium Ionic Strength Adjustor (ISA) Powder Pillow. **Do not store the probe in deionized water or in samples.**

For long-term storage (more than 24 hours), close the filling hole and put the soaker bottle with 0.02 M NH₄Cl on the probe. Refer to [Figure 6](#). Keep the probe in a vertical position with the sensor and reference junction below the liquid level in the soaker bottle. Add 0.02 M NH₄Cl to the soaker bottle if necessary.

Note: Before use after long-term storage, condition the probe in 25 mL of a 100 mg/L Na⁺ standard solution with one Sodium ISA pillow (0.4 g) for 8 hours or more.

Figure 6 Probe storage

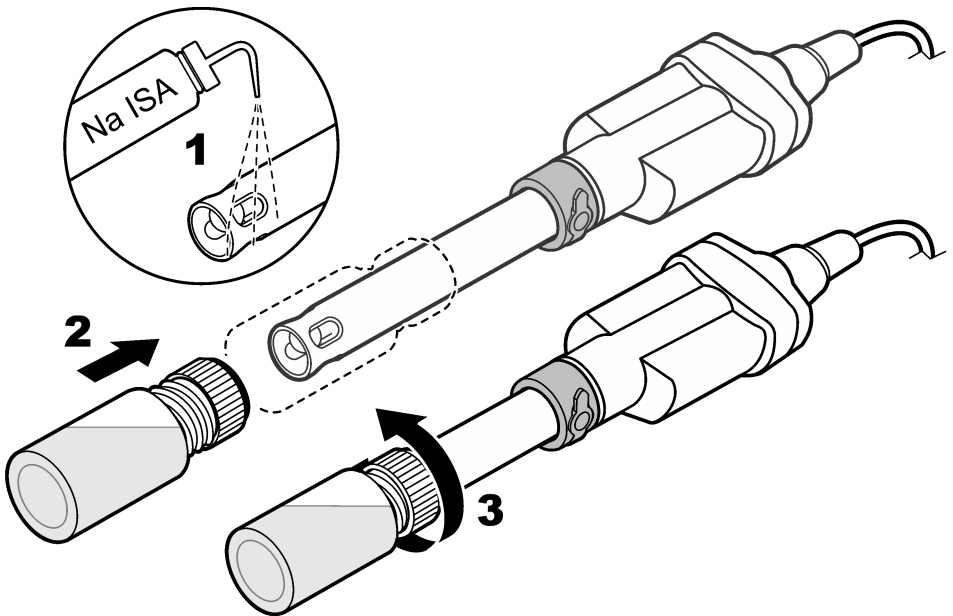

Section 9 Troubleshooting

Refer to [Table 2](#) for general troubleshooting information. To check the probe performance, refer to [Slope check](#) on page 15. To check the accuracy of sample measurements, refer to [Standard additions check](#) on page 15.

Table 2 Troubleshooting information

Problem	Possible cause	Solution
Decreased probe performance causes slow stabilization and prevents accurate calibrations or measurements.	The glass sensor is dirty.	Clean and condition the probe. Refer to Clean the probe on page 12.
	The filling solution has contamination.	Replace the filling solution. Refer to Replace the filling solution on page 13.
	The reference junction is clogged.	Fully rinse the reference junction with sodium ISA rinse solution. Shake the probe down to remove air bubbles.
	The probe is not conditioned to the sample sufficiently.	Condition the probe. Refer to Preparation for use on page 5.
	The glass bulb has become dry.	Soak the probe tip in 25 mL of 100 mg/L sodium standard solution with one sodium ISA powder pillow for 8 hours or more.
Sample properties cause slow stabilization or inaccurate measurements.	The sample pH with ISA is less than pH 9.	Make sure that the sample pH after the ISA is added is higher than pH 9. Make sure to add one ISA pillow per 25 mL of sample.
	The sample temperature is low, or there is a large temperature difference between samples.	Increase the sample temperature or adjust the temperature of different samples to be the same (within 2 °C (3.6 °F)).
Procedure problem causes slow stabilization and prevents accurate calibrations or measurements.	The filling hole is closed.	Open the filling hole during use.
	The stir speed is too slow or too fast.	Try a different stir speed.
	Air bubbles are around or below the probe tip.	Carefully tap or shake the probe to remove air bubbles.
	Magnetic stirrers can become warm and increase the solution temperature.	Put a piece of insulating material between the stirrer and beaker.
	The ISA was not added.	Add one ISA powder pillow to each 25 mL of sample and standard solution.
	An incorrect standard solution was used or the standard solution has contamination.	Use the specified standard solution of good quality.
	The protective tape was not removed from the filling hole.	Remove the tape from the filling hole. Refer to Preparation for use on page 5.

9.1 Slope check

Use the mV value of two standard solutions to make sure the probe gives the correct slope.

1. Prepare two standard solutions that are ten times apart in concentration (e.g., 10 mg/L and 100 mg/L Na⁺). Select standard solutions with a concentration above and below the typical sample concentration. Use a minimum concentration of 1.4 mg/L.
2. Use the measurement procedure to add the ISA and measure the mV value of each standard solution.
3. Calculate the difference in the mV value of the two standard solutions to find the slope. If the probe is in good condition, the slope will be 59 mV (within the \pm slope limits of the method) at 25 °C (77 °F).

9.2 Standard additions check

To make sure that the sample measurement is accurate, add a small volume of a standard solution to the sample and calculate the percent recovery. The sample with the known volume of standard solution is known as a spiked sample.

1. Use the measurement procedure to measure the concentration of a 25-mL sample.
2. Use a pipet to add the applicable volume of standard solution to the sample. Refer to [Table 3](#).

Table 3 Standard solution volumes and concentrations

Measured sample concentration	Volume of standard to add	Concentration of standard solution
1 to 2 mg/L	0.5 mL	100 mg/L Na ⁺
3 to 6 mg/L	1.0 mL	100 mg/L Na ⁺
7 to 15 mg/L	0.3 mL	1000 mg/L Na ⁺
15 to 30 mg/L	0.5 mL	1000 mg/L Na ⁺
30 to 60 mg/L	1.0 mL	1000 mg/L Na ⁺

3. Measure the concentration of the spiked sample.
4. Calculate the expected (theoretical) concentration of the spiked sample:
$$C_E = (C_S \times V_S/V_T) + (C_{SS} \times V_{SS}/V_T)$$

Where:

 - C_E = expected (theoretical) concentration of the spiked sample
 - C_S = concentration of the sample (mg/L) before the standard solution was added
 - C_{SS} = concentration of the standard solution (mg/L)
 - V_S = sample volume (mL) before the standard solution was added
 - V_{SS} = volume of the standard solution (mL)
 - V_T = total volume (standard solution volume (mL) + sample volume)
5. Calculate the percent recovery of the standard addition. A percent recovery of 100 (± 5)% is an indication that the sample measurements are accurate.

$$\text{Percent recovery} = C_M/C_E \times 100$$

Where:

- C_M = measured concentration of the sample after the addition of the standard solution
- C_E = expected (theoretical) concentration of the sample after the addition of the standard solution

Section 10 Consumables

Note: Product and Article numbers may vary for some selling regions. Contact the appropriate distributor or refer to the company website for contact information.

Table 4 Recommended cleaning solutions

Description	Quantity	Item no.
Electrode cleaning solution for regular maintenance	500 mL	2756549
Electrode cleaning solution for minerals or inorganic contamination	500 mL	2965249
Electrode cleaning solution for proteins or organic contamination	500 mL	2975149
Electrode cleaning solution for fats, oils and grease contamination	250 mL	C20C370
Electrode cleaning solution, extra strong	500 mL	2964449
Electrode cleaning solution, extra strong	250 mL	S16M002

Table 5 Recommended standards and reagents

Description	Quantity	Item no.
Sodium standard solution, 10 mg/L as Na	1 L	2835153
Sodium standard solution, 100 mg/L as Na	500 mL	2318149
Sodium standard solution, 100 mg/L as Na	1 L	2318153
Sodium standard solution, 1000 mg/L as Na	500 mL	1474949
Electrode filling solution, ISENa381, 0.02 M NH ₄ Cl	59 mL	2965126
Sodium/Potassium Ionic Strength Adjustor (ISA) Powder Pillows	100/pkg	4451569

10.1 Accessories

Description	Quantity	Item no.
Beaker, polypropylene, 50 mL, low form	1	108041
Disposable wipes, 11 x 22 cm	280/pkg	2097000
Wash bottle, polyethylene, 500 mL	1	62011
Probe stand for standard Intellical probes	1	8508850
Soaker bottle for probe storage	1	5192900



HACH COMPANY World Headquarters

P.O. Box 389, Loveland, CO 80539-0389 U.S.A.
Tel. (970) 669-3050
(800) 227-4224 (U.S.A. only)
Fax (970) 669-2932
orders@hach.com
www.hach.com

HACH LANGE GMBH

Willstätterstraße 11
D-40549 Düsseldorf, Germany
Tel. +49 (0) 2 11 52 88-320
Fax +49 (0) 2 11 52 88-210
info-de@hach.com
www.de.hach.com

HACH LANGE Sàrl

6, route de Compois
1222 Vézenaz
SWITZERLAND
Tel. +41 22 594 6400
Fax +41 22 594 6499