



LANGE 

DOC013.52.90269

BÜHLER 1027, 1029, 2000 Portable Sampler

Short Manual

08/2011, Edition 3A

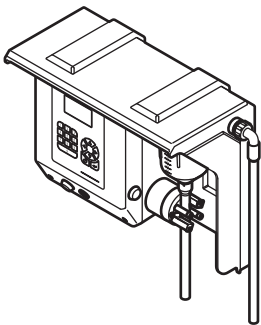

1027

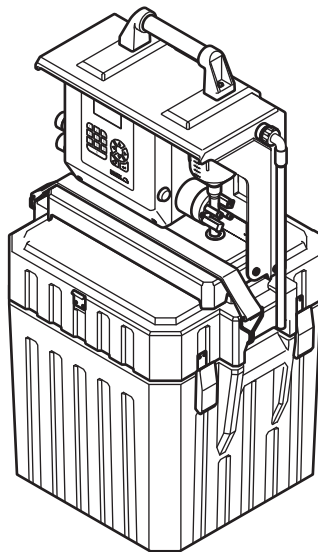

1029

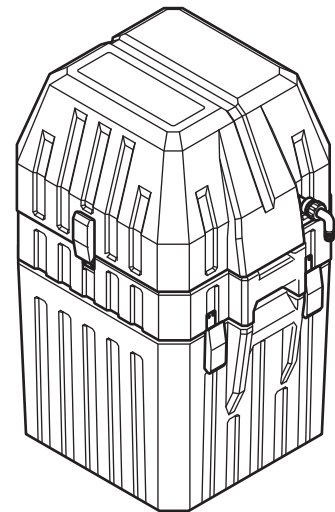

2000

Table of Contents

Section 1 Specifications	5
1.1 Dimensions	6
Section 2 General Information	7
2.1 Safety information.....	7
2.1.1 Use of hazard information.....	7
2.1.2 Precautionary labels	7
2.2 General Information	8
2.2.1 Areas of application	8
2.2.2 Functional description.....	8
2.3 Product contents.....	8
Section 3 Installation	11
3.1 Mechanical installation.....	12
3.1.1 Required tools.....	12
3.1.2 Installation location (1027).....	13
3.1.3 Position (1029 and 2000).....	14
3.1.4 Attach the sampler compartment to the bottle compartment (1029).....	15
3.2 Electrical connections	15
3.2.1 Electrical installation	16
3.2.1.1 Prepare the electrical installation	16
3.2.1.2 Wiring diagram.....	17
3.2.2 Installation of the optional bottle compartment with active cooling (1029/2000).....	18
3.3 Commission of the equipment	20
3.3.1 Tube connection	20
3.3.2 Set the individual sample volumes.....	21
3.3.2.1 Plastic dosing vessel.....	21
3.3.2.2 Glass dosing vessel	23
3.3.2.3 Dosing vessel for flow-proportional sampling	25
3.3.3 Remove the top part of the housing (1029)	27
3.3.4 Remove the top part of the housing (2000)	28
3.3.5 Prepare the bottle compartments.....	28
3.3.6 Attach the top part of the housing.....	29
3.3.7 Connect the equipment to the mains	30
3.3.8 Switch on the device	32
3.3.9 Adjust the cooling settings for the optional bottle compartment with active cooling (1029 and 2000).....	33
Section 4 Operation	35
4.1 Control unit operation	35
4.1.1 Password	35
4.1.2 Programming	35
4.1.3 Keyboard layout/function	35
4.2 Normal operation	37
4.2.1 Replace the sample bottles.....	37

Section 5 Maintenance and cleaning	39
5.1 Maintenance tasks	39
5.2 Cleaning	39
5.2.1 Clean the housing and distribution unit (1029–2000).....	39
5.2.2 Clean the dosing vessel	41
5.3 Troubleshooting	43
5.3.1 Change the fuse	43
5.4 Instrument decommissioning and storage.....	45
Section 6 Replacement parts and accessories	47
6.1 Spare parts.....	47
6.2 Accessories	50
Section 7 Warranty and Liability	53
Section 8 Contact information	55

Section 1 Specifications

These are subject to change without notice.

	BÜHLER 1027	BÜHLER 1029	BÜHLER 2000	BÜHLER 1029	BÜHLER 2000
	Without active cooling			With active cooling	
Electrics					
Power supply, sampler compartment					
With integrated battery	–	12 V (DC)		12 V (DC)	
With integrated power pack	110–230 V/ 50–60 Hz.	–			
With optional power pack	–	110–230 V/50–60 Hz.			
Power supply, bottle compartment					
With integrated power pack	–			12 V (DC) 110 V/60 Hz 230 V/50 Hz	or (optional) or (optional)
Rating	16 A				
Power consumption	approx. 30 VA			approx. 50 VA	
Environment					
Medium temperature	0 to 40°C [32 to 104 °F]				
Ambient temperature	0 to 50 °C [32 to 122 °F]			0 to 43 °C [32 to 110 °F]	
Delivery height	< 6 m [20 ft], optional < 8 m [26 ft]				
General specifications					
Coolant	–			R134a	
Maintenance requirements	Maintenance-free				
Weight					
Top part	approx. 6.6 kg	approx. 10 kg	approx. 14.3 kg	approx. 10 kg	approx. 14.3 kg
Bottle compartment	–	approx. 11 kg		approx. 25 kg	
Complete	–	approx. 22 kg	approx. 25 kg	approx. 35 kg	approx. 40 kg
Dimensions (W x H x D)					
Top part	475 x 362 x 222 [18.7x14.3x8.7]	445 x 442 x 222 [17.5x17.4x8.7]	510 x 390 x 468 [20x15.4x18.4]	445 x 442 x 222 [17.5x17.4x8.7]	510 x 390 x 468 [20x15.4x18.4]
Bottle compartment	–	510 x 534 x 430 [20 x 21 x 16.9]		550 x 775 x 468 [21.7 x 30.5 x 18.4]	
Complete	–	510 x 942 x 430 [20 x 37 x 16.9]	510 x 787 x 468 [20 x 31 x 18.4]	510 x 970 x 468 [20x38.2x18.4]	550 x 1028 x 468 [21.7x40.5x18.4]
With cap opened (55°)	–	–	510 x 970 x 468 [20x38.2x18.4]	–	510 x 1210 x 468 [20 x 47.6 x 18.4]
Certification					
Certification	CE, sampling in accordance with ISO 5667-2/3-10				

1.1 Dimensions

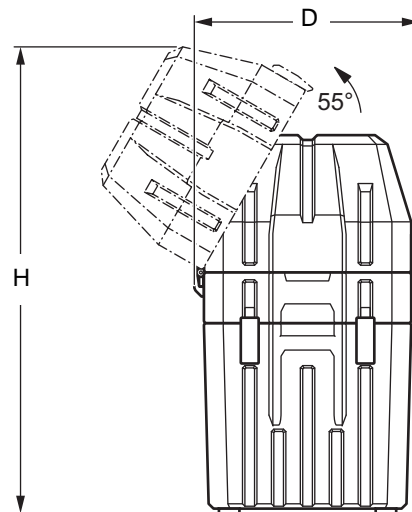
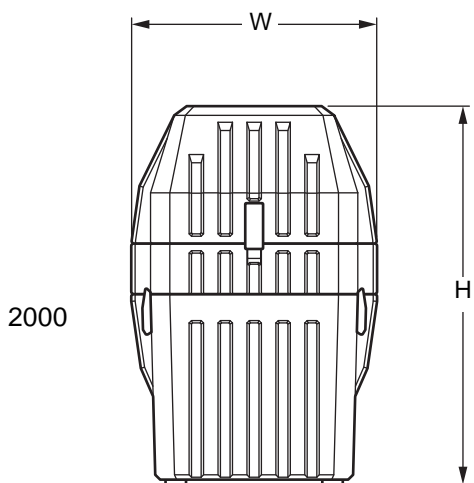
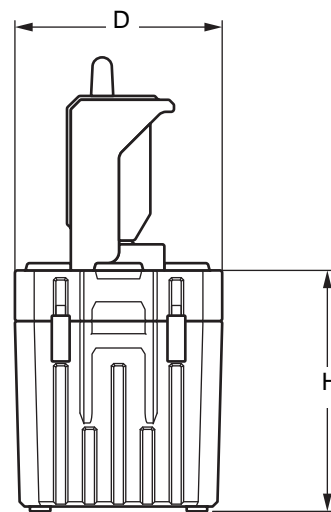
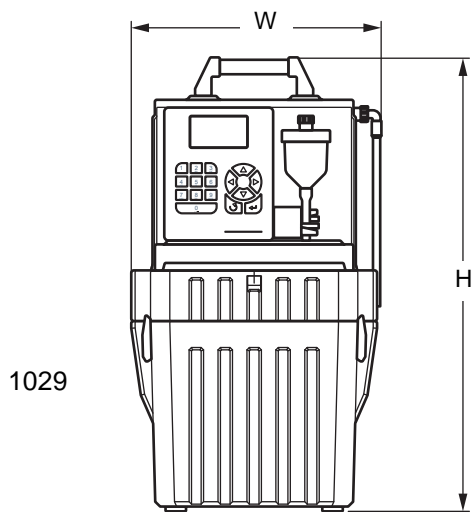
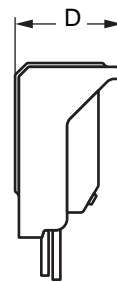
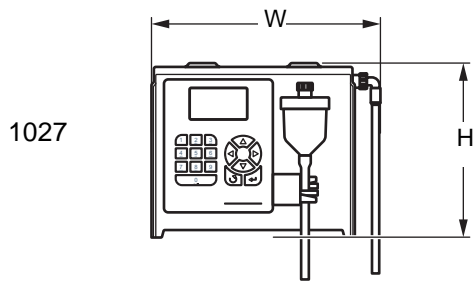

W x H x D: see the specifications table

Figure 1 Dimensions

Section 2 General Information

2.1 Safety information

Please read this entire manual before unpacking, setting up, or operating this equipment. Pay attention to all danger and caution statements. Failure to do so may result in personal injury or damage to the instrument.

To ensure that the protection provided by this equipment is not impaired, do not use or install this equipment in any manner other than that specified in this manual.

2.1.1 Use of hazard information



DANGER

Indicates a potentially or imminently hazardous situation which, if not avoided, will result in death or serious injury.



WARNING

Indicates a potentially or imminently hazardous situation that, if not avoided, could result in death or serious injury.



CAUTION

Indicates a potentially or imminently hazardous situation that could result in minor or moderate injury.

Important note: Information that requires special emphasis.



Note: Information that supplements points in the main text.

2.1.2 Precautionary labels

Read all labels and tags attached to the instrument. Failure to do so may result in personal injury or damage to the instrument. A symbol, if noted on the instrument, will be included with a danger or caution statement in the manual.

	This symbol, if noted on the instrument, references the user manual for operation and/or safety information.
	This symbol, when noted on a product enclosure or barrier, indicates that a risk of electrical shock and/or electrocution exists.
	This symbol may appear on the product and indicates the need for protective eye wear.
	This symbol may appear on the product and identifies the connection point for the protective ground.

General Information

	When this symbol appears on the product, it identifies the location of a fuse or a current limiter.
	<p>Electrical equipment marked with this symbol may not be disposed of in European domestic or public disposal systems after 12 August 2005. In conformity with European local and national regulations (EU Directive 2002/96/EC), European electrical equipment users must now return old or end-of-life equipment to the manufacturer for disposal at no charge to the user.</p> <p>Note: For return for recycling, please contact the equipment manufacturer or supplier for instructions on how to return end-of-life equipment, manufacturer-supplied electrical accessories, and all auxiliary items for proper disposal.</p>

2.2 General Information

2.2.1 Areas of application

The equipment is used for sampling aqueous liquids with a temperature of 0 °C to 50 °C (refer to [Section 1 Specifications, page 5](#)).

2.2.2 Functional description

The equipment provides temporary storage for liquids of a specified volume so that they can be analyzed.

2.3 Product contents

The equipment is supplied with a tube and brief operating instructions. Depending on the model, the equipment is also supplied with a plug (1027/active cooled bottle compartment), tension belt (1029) or an optional charger (1029/2000). If you require further information, you can order the operating instructions (refer to [Section 6 Replacement parts and accessories, page 47](#)) from the manufacturer or you can download them from the Internet.

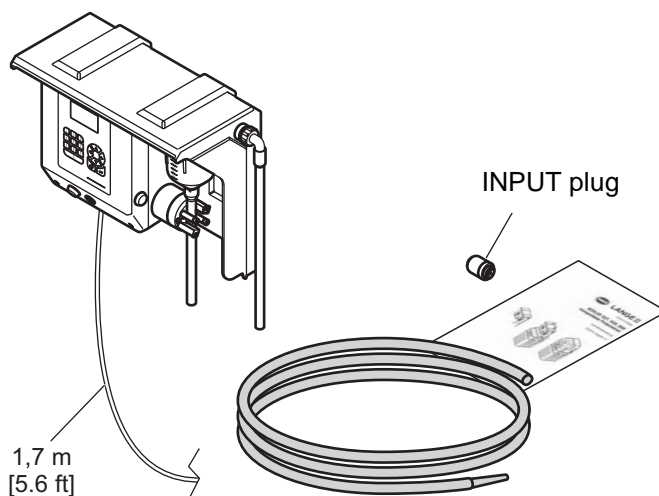

Figure 2 Scope of delivery (1027)

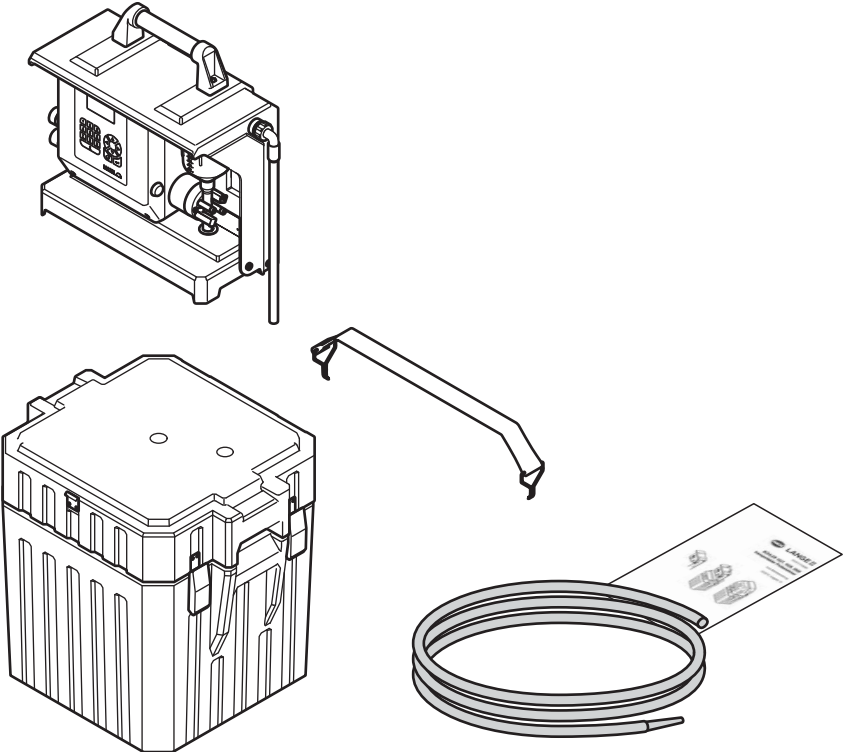

Figure 3 Scope of delivery (1029)

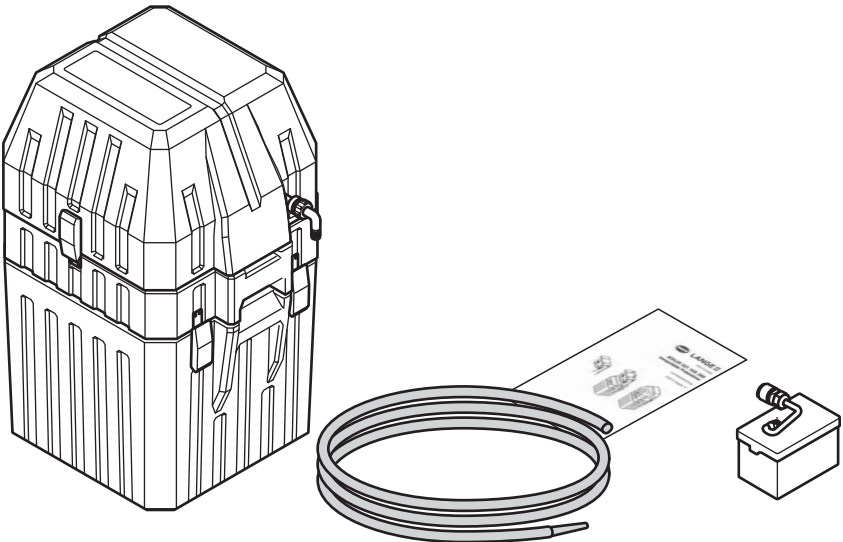

Figure 4 Scope of delivery (2000)

Section 3 Installation



DANGER

Only qualified experts should conduct the tasks described in this section.



DANGER

Select an appropriate installation location for the instrument.

Plan out the mechanical mount-before positioning poles or drilling holes. Make sure the mount has a sufficient bearing capacity. The dowels must be selected and authorized according to the condition of the wall.

The manufacturer shall accept no liability if the instrument is installed incorrectly.

Plan how to lay cables and tubes and their path in advance. Lay the tubes, data cables and power cables without any bends and so they do not pose a tripping risk.

Do not connect the electrical supply to the mains if the equipment has not been wired and fused correctly.

Sufficiently protect the electrical power supply against short circuits.

For the external power supply, always connect a residual-current circuit breaker-(trip current max.: 30 mA) between the mains and the system.

If the equipment is to be installed outdoors, switch the overload protection between mains and system.

Products intended by the manufacturer for outdoor use offer a higher level of protection against the penetration of liquids and dust. If these products are connected to a mains outlet with a cable and plug-rather than a permanently connected cable, the plug and outlet are much more susceptible to liquid and dust penetration. The operator must sufficiently protect the plug and outlet against liquid and dust penetration in accordance with local safety regulations. If the instrument is to be used outdoors, it must be connected to a suitable outlet with a protection type of at least IP44 (splash protection).

3.1 Mechanical installation



DANGER

Select an appropriate installation location for the instrument.

Plan out the mechanical mount before positioning poles or drilling holes. Make sure the mount has a sufficient bearing capacity. The dowels must be selected and authorized according to the condition of the wall.

The manufacturer shall accept no liability if the instrument is installed incorrectly.

Plan how to lay cables and tubes and their path in advance. Lay the tubes, data cables and power cables without any bends and so they do not pose a tripping risk.

Note: For information on installation with optional accessories, refer to the relevant installation instructions.

3.1.1 Required tools

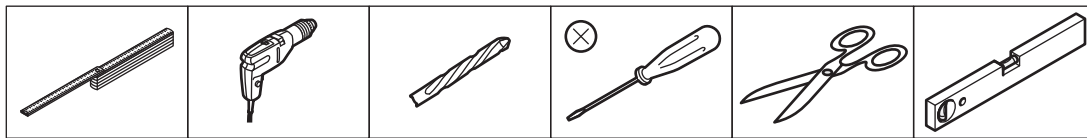

Figure 5 Required tools (1027)

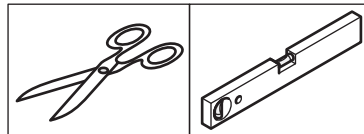

Figure 6 Required tools (1029 and 2000)

3.1.2 Installation location (1027)

Select suitable fastening materials (e.g. 6 × 40 mm screws and corresponding dowels) and read all the safety information about installation and mechanical assembly.

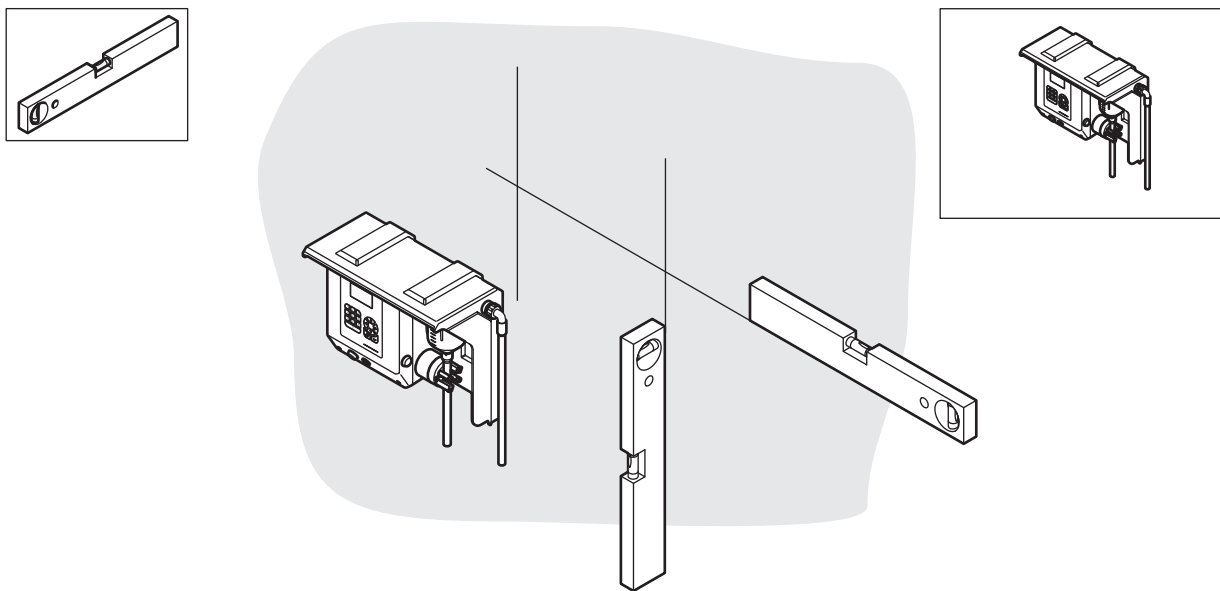

Figure 7 Select installation location (1027)

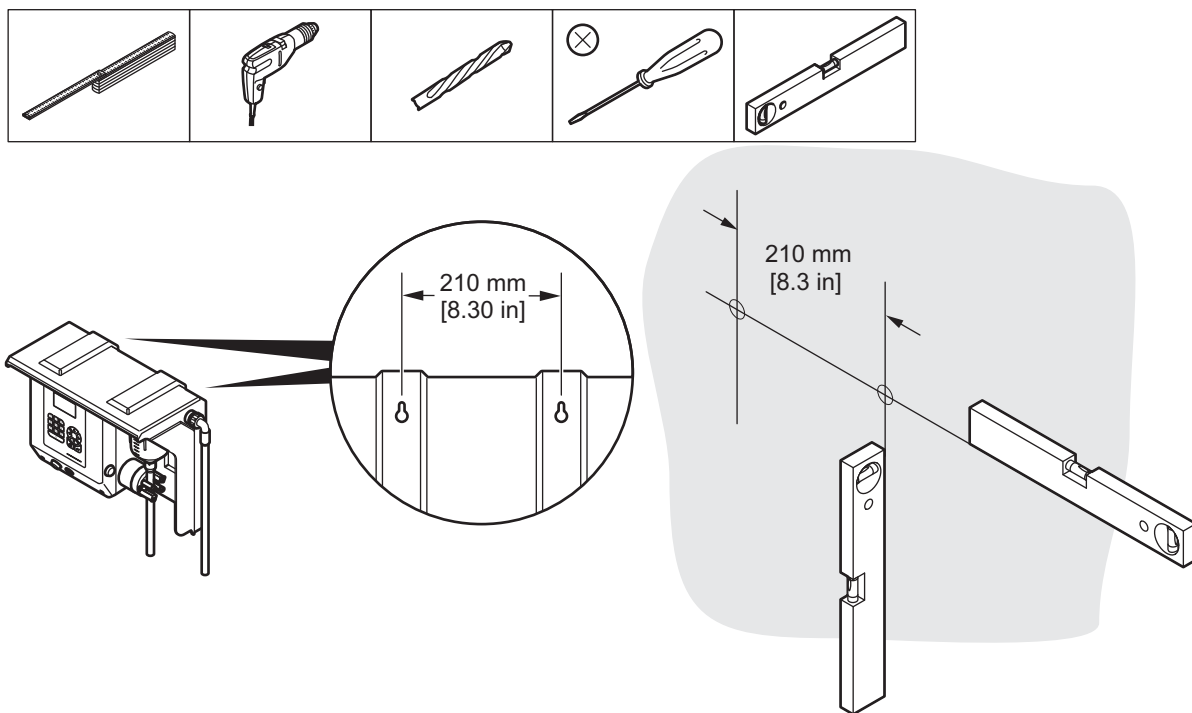

Figure 8 Attach the equipment (1027)

Installation

3.1.3 Position (1029 and 2000)

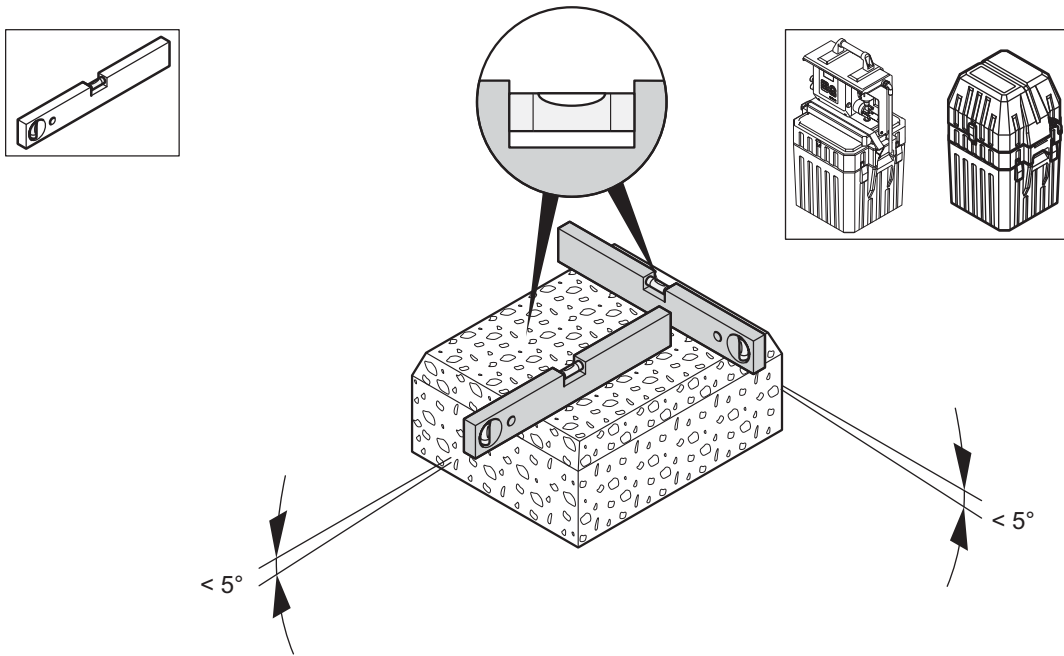

Figure 9 Select the position (1029 and 2000)

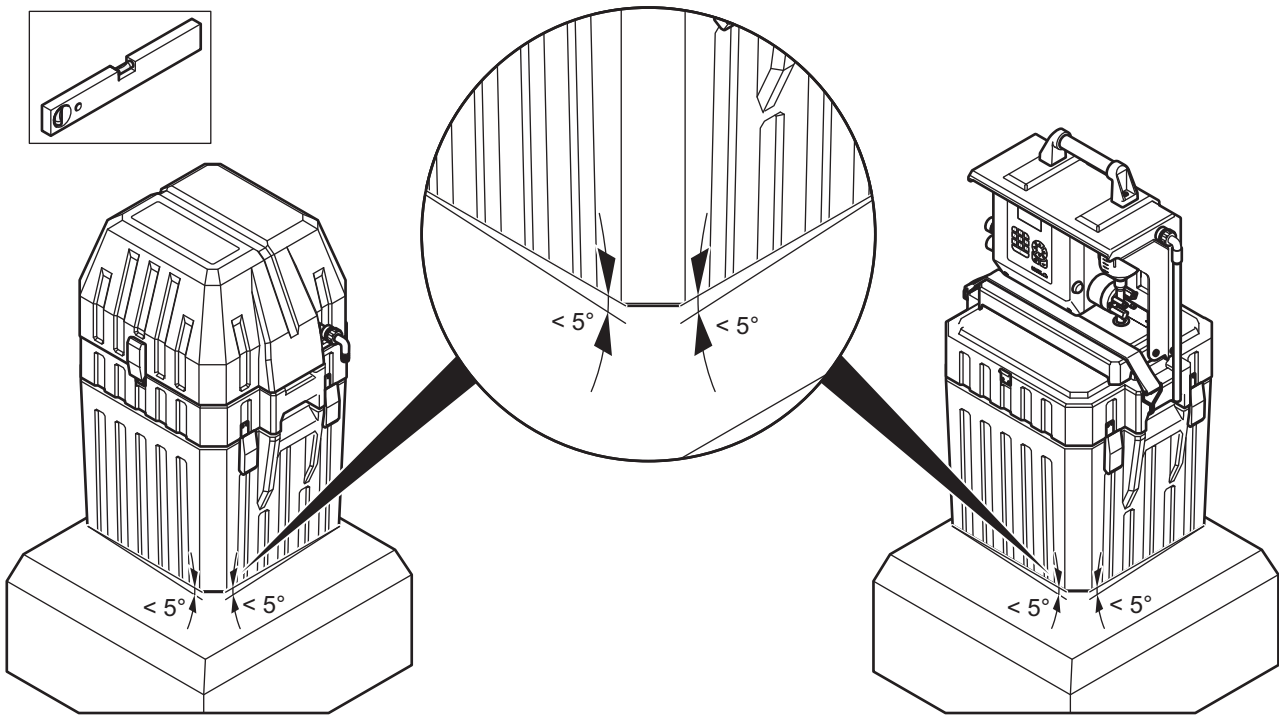

Figure 10 Position the equipment (1029 and 2000)

3.1.4 Attach the sampler compartment to the bottle compartment (1029)

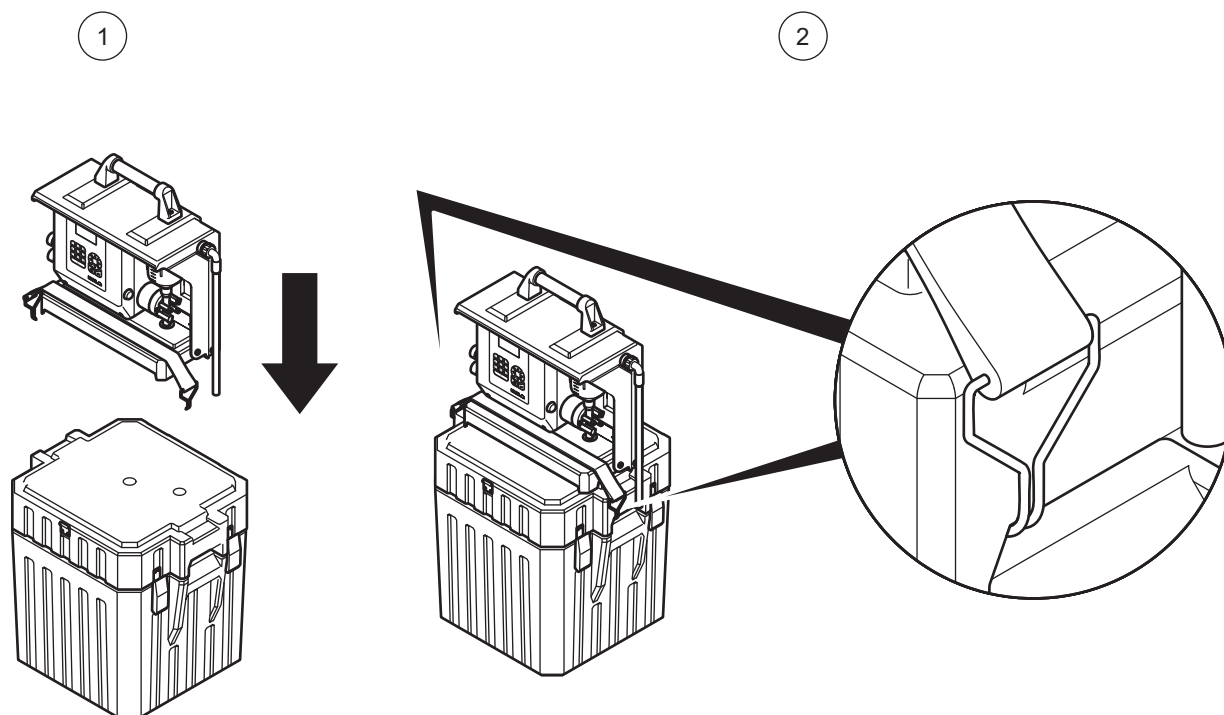

Figure 11 Attach the sampler compartment to the bottle compartment (1029)

3.2 Electrical connections



DANGER

Only qualified experts should conduct the tasks described in this section.



DANGER

Do not connect the electrical supply to the mains if the equipment has not been wired and fused correctly.

Sufficiently protect the electrical power supply against short circuits.

For the external power supply, always connect a residual-current circuit breaker (trip current max.: 30 mA) between the mains and the system.

If the equipment is to be installed outdoors, switch the overload protection between mains and system.

If the mains plug of the power supply cable is removed, a suitable double-pole one-way switch must be installed immediately next to the display unit with clear labeling for the power supply.

Products intended by the manufacturer for outdoor use offer a higher level of protection against the penetration of liquids and dust. If these products are connected to a mains socket with a cable and plug rather than a permanently

Installation

connected cable, the plug and socket are much more susceptible to liquid and dust penetration. The operator must sufficiently protect the plug and outlet against liquid and dust penetration in accordance with local safety regulations. If the instrument is to be used outdoors, it must be connected to a suitable outlet with a protection type of at least IP44 (splash protection).

3.2.1 Electrical installation

3.2.1.1 Prepare the electrical installation

	In battery mode	In mains power mode
1027	–	No preparation required
1029	No preparation required	Connect the optional charger to the charge socket on the left-hand side.
2000	No preparation required	Connect the Y cable as shown in Figure 12 .

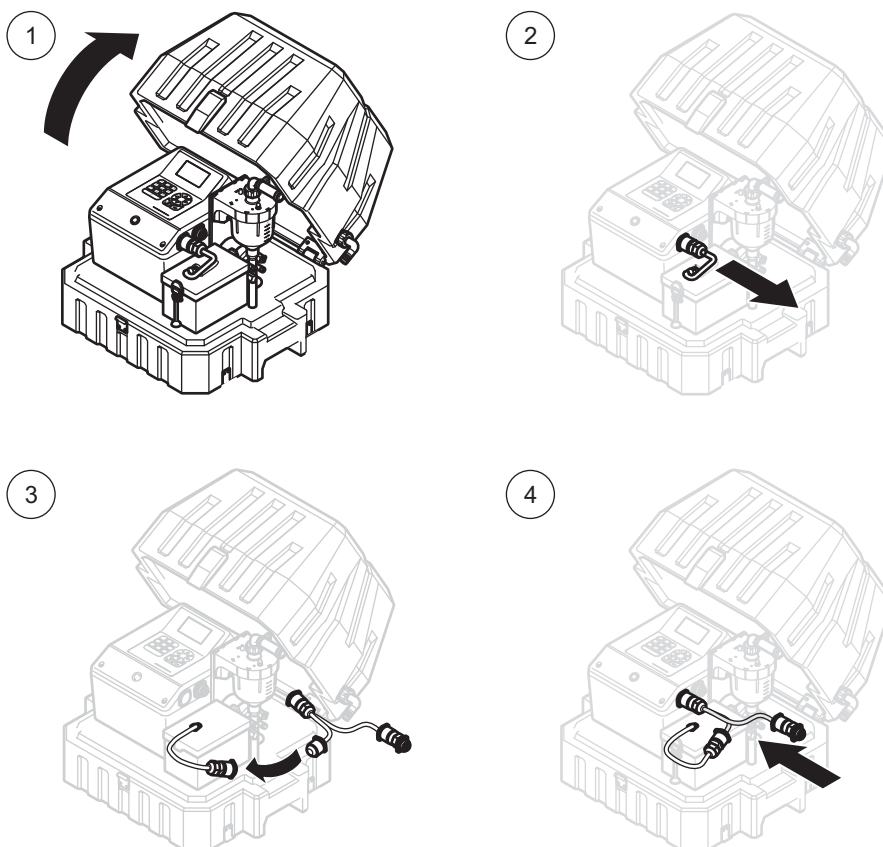

Figure 12 Connect the Y cable (2000)

To connect the equipment to the mains, see [Figure 36 Model 2000 with Y cable and charger on page 31](#).

3.2.1.2 Wiring diagram

Please note:

- The assignment of the connections in the illustration below
- The cable color of the label on the cable

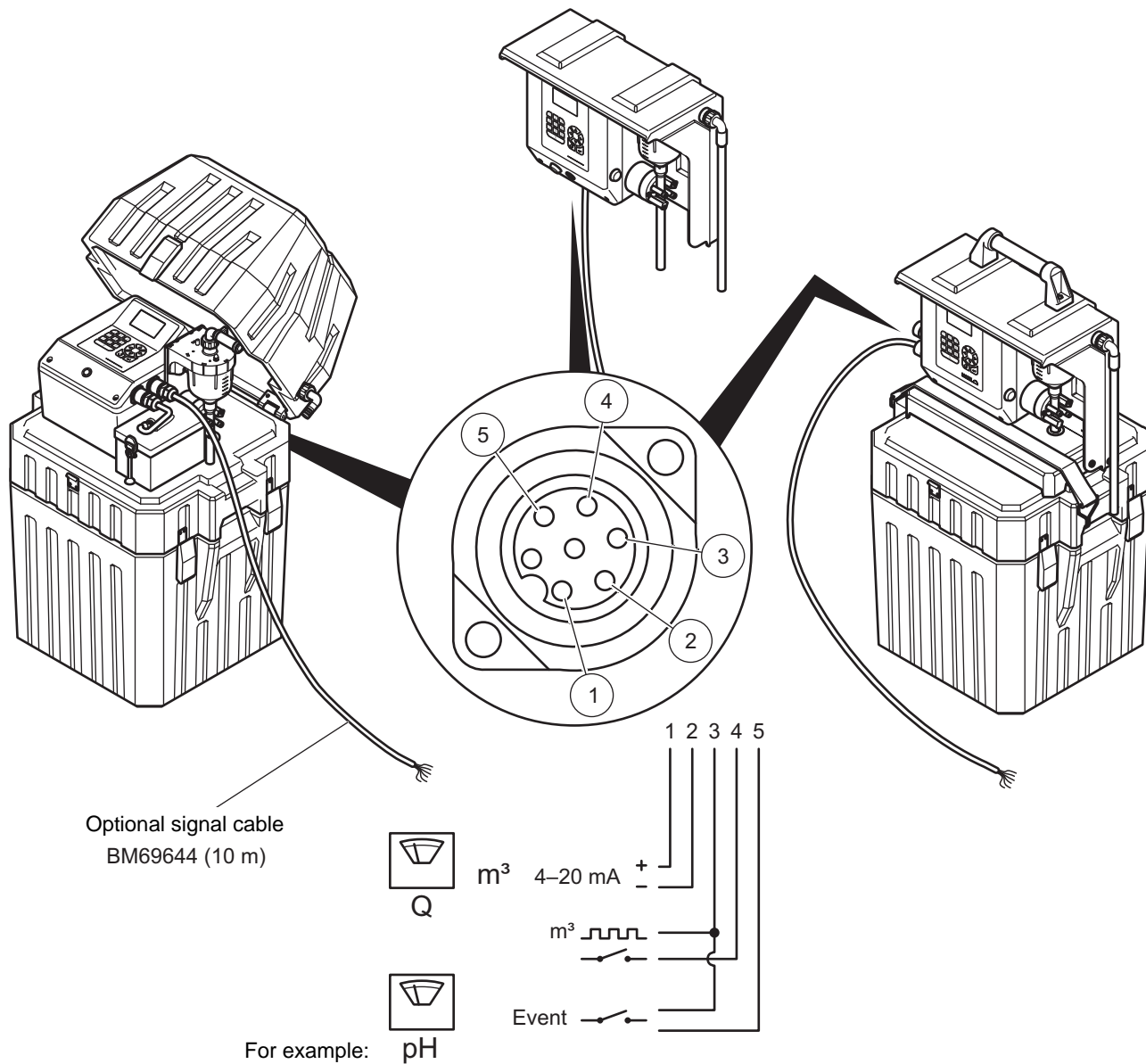

Figure 13 Connection plan for the optional signal cable (BM69644)

Installation

3.2.2 Installation of the optional bottle compartment with active cooling (1029/2000)

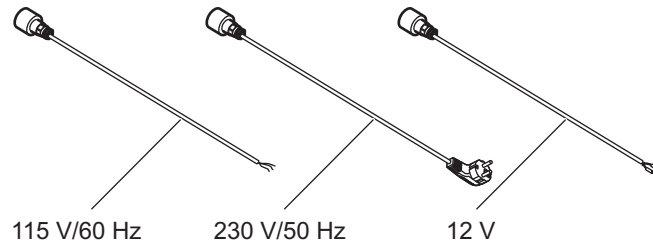

Figure 14 Select the cable for the optional bottle compartment with active cooling (1029/2000)

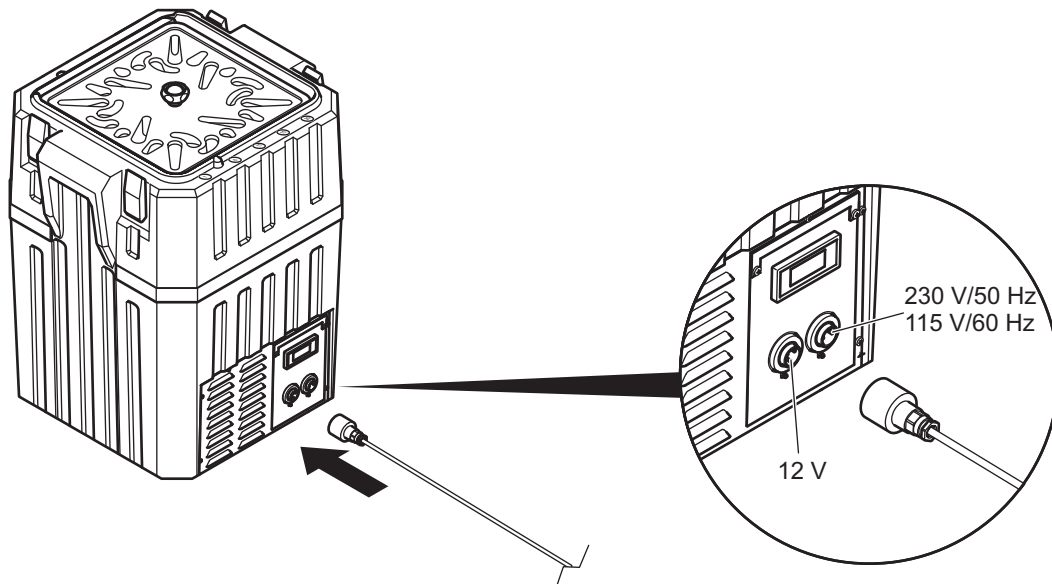

Figure 15 Connect the optional bottle compartment with active cooling

Important note: Blocked air outlets and liquids in the cooling machine or inside the optional bottle compartment with active cooling can damage the equipment. Make sure that the air outlets are always open and that no liquid is able to enter the air outlets.

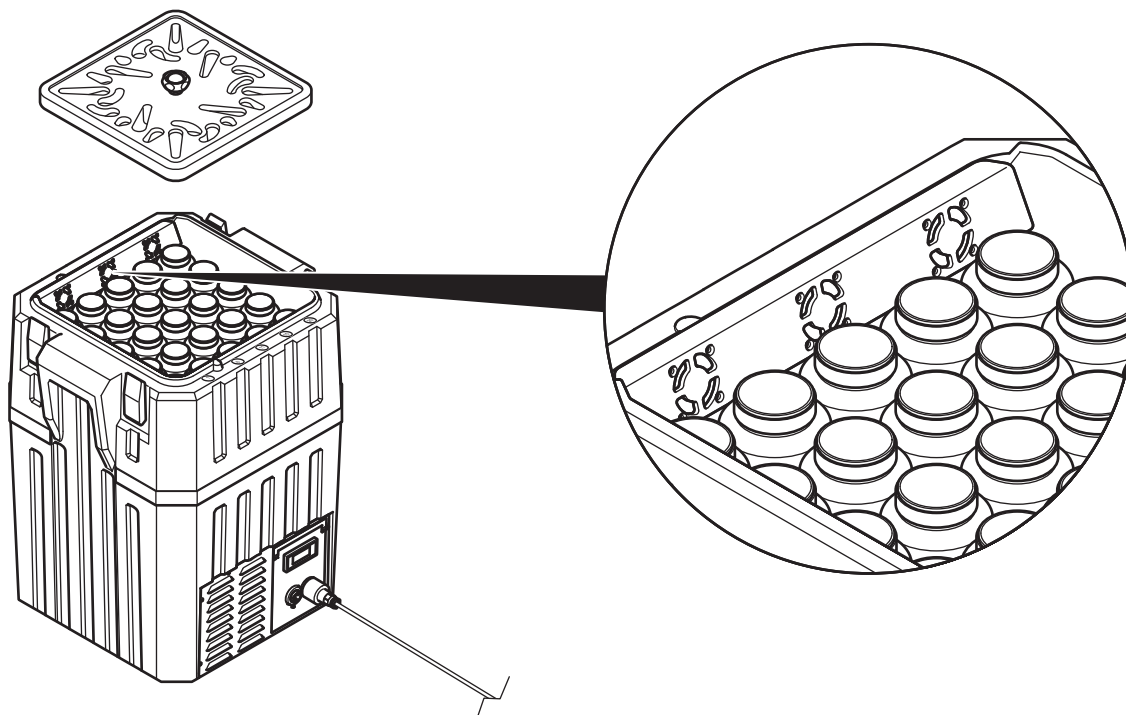

Figure 16 Sample distributor plate and air outlets on the optional bottle compartment with active cooling

Note: The housing base on the bottle compartment features numbers so that the individual bottles can be assigned with a number.

3.3 Commission of the equipment

3.3.1 Tube connection

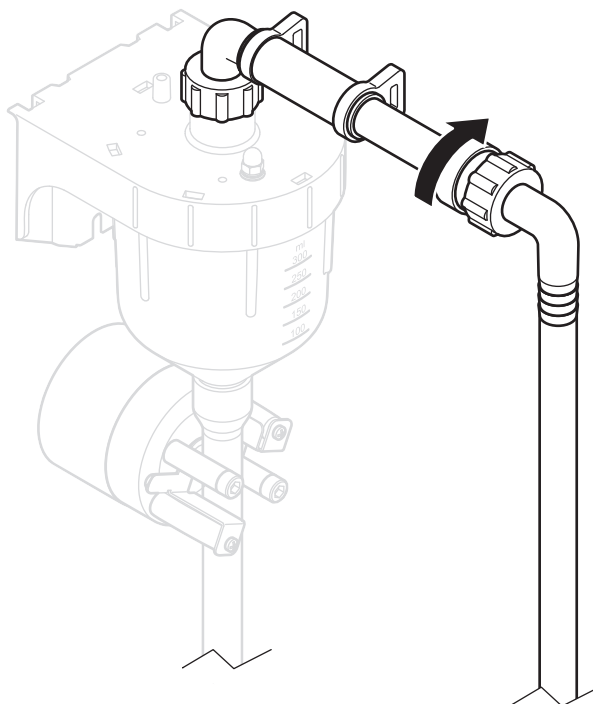

Figure 17 Connect the sample tube connection

Positioning of the tubes according to the following installation diagram.

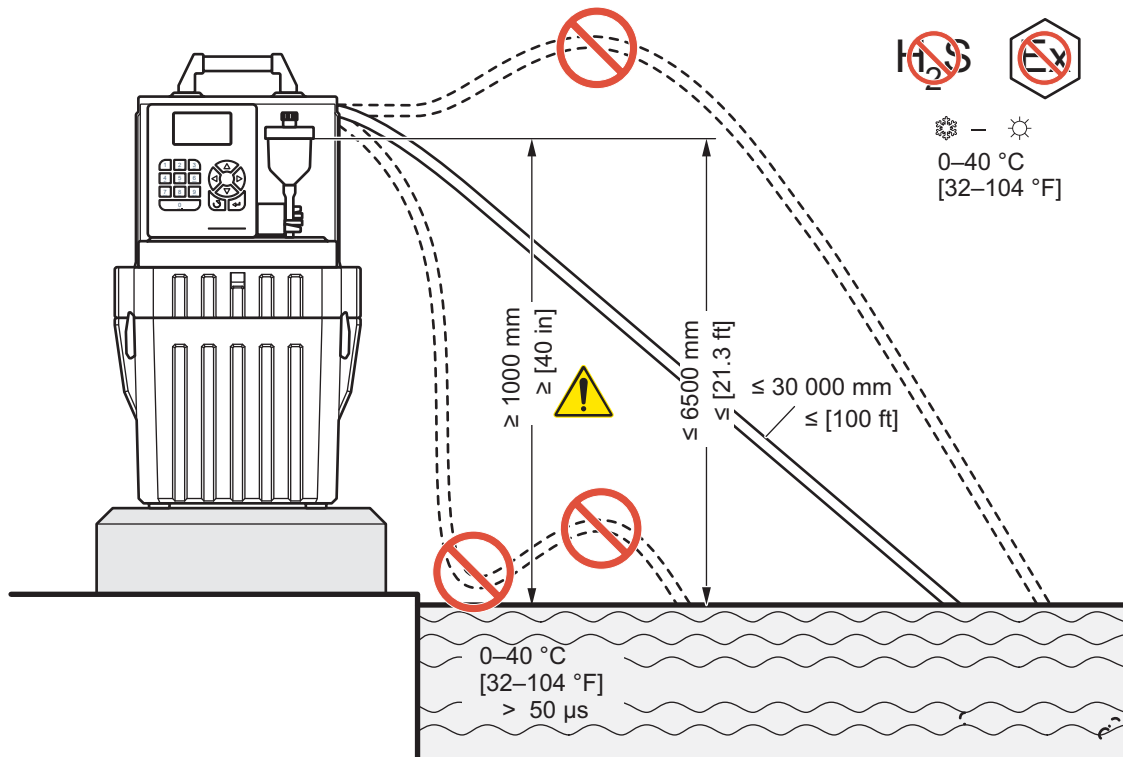

Figure 18 Installation diagram

3.3.2 Set the individual sample volumes

3.3.2.1 Plastic dosing vessel

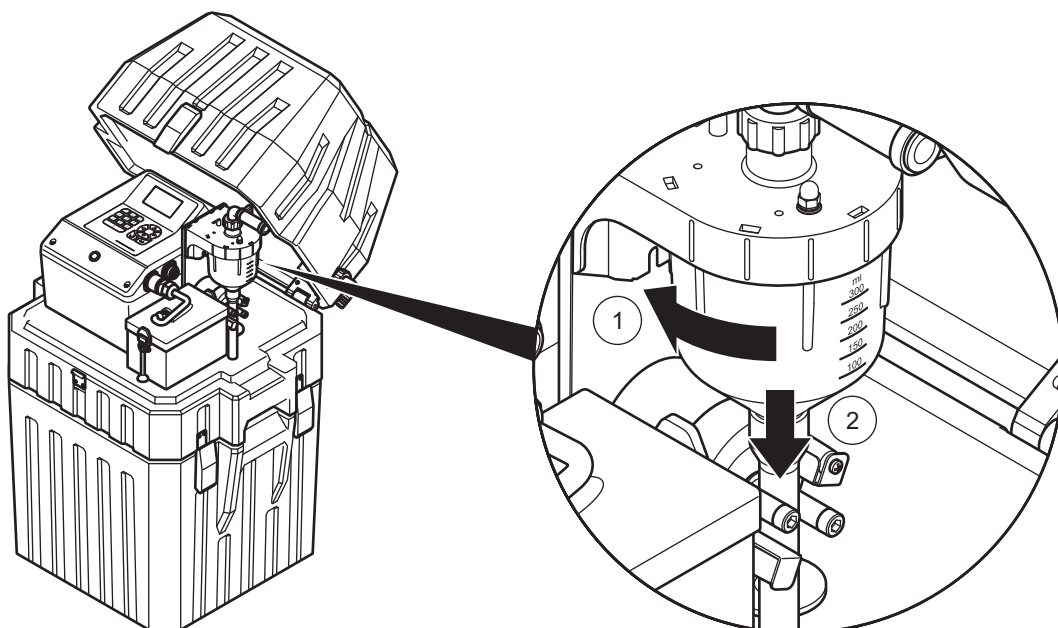

Figure 19 Unlock the bayonet cap on the plastic dosing vessel

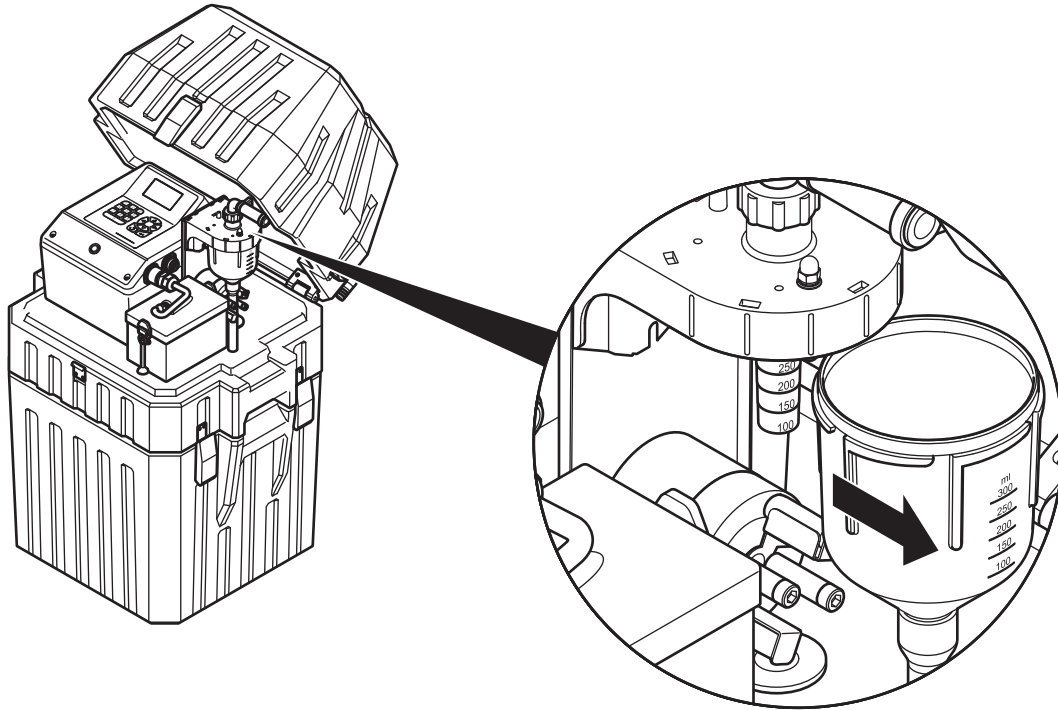

Figure 20 Remove the plastic dosing vessel

	V-Probe [mL]
---	--------------

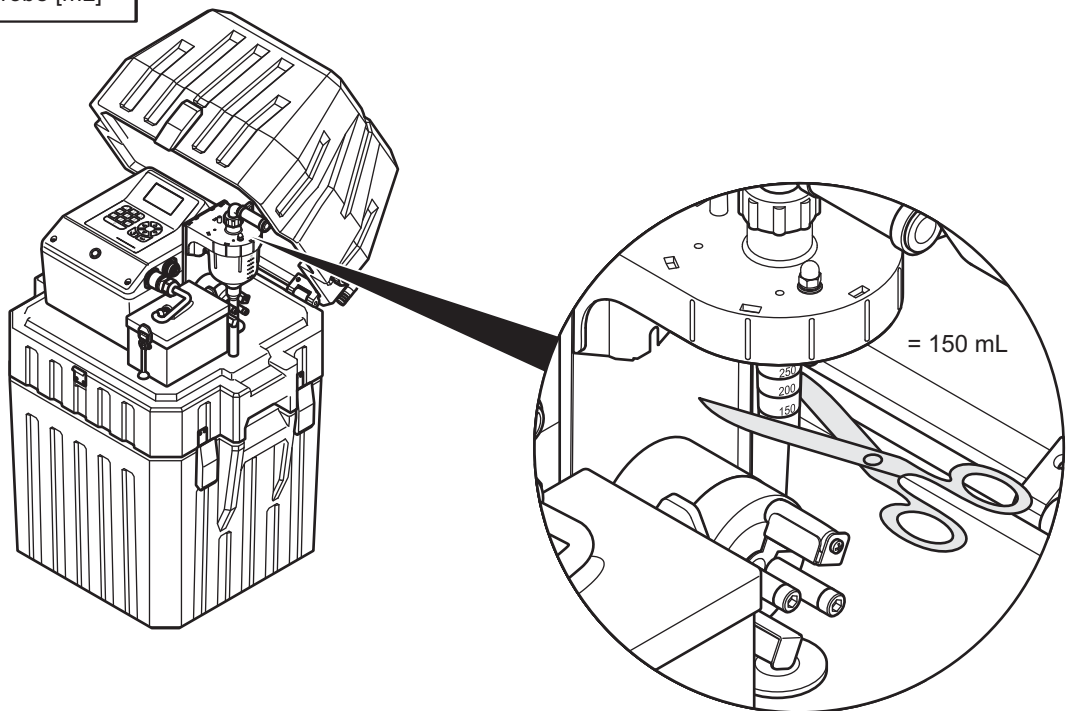

Figure 21 Cut the dosing tube to set the sample volume

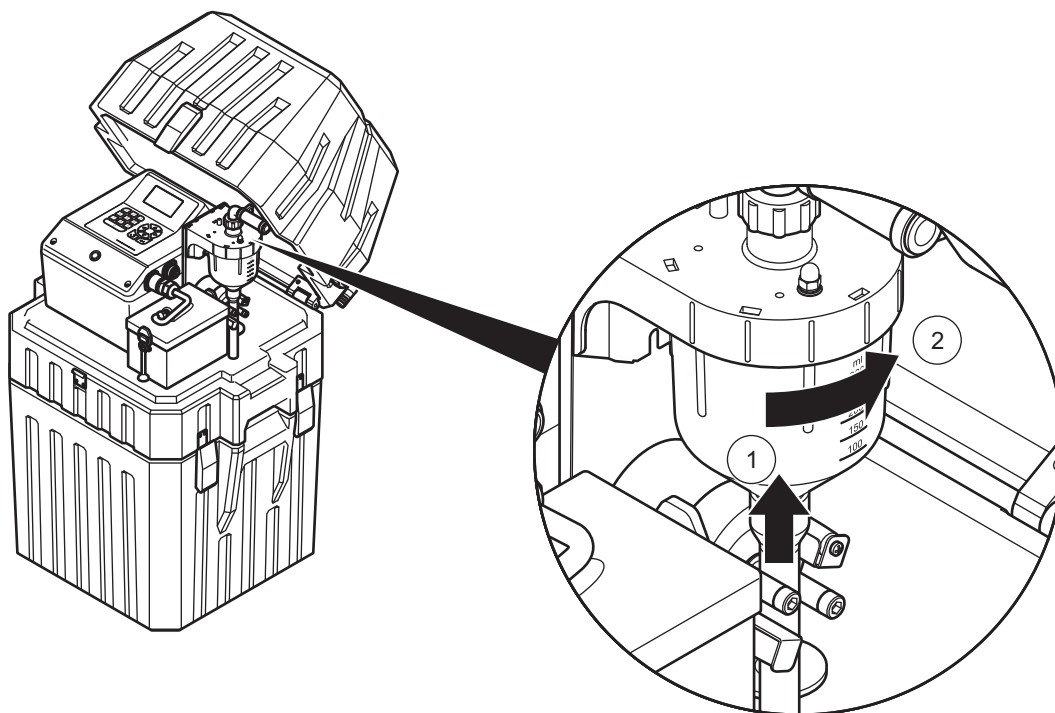

Figure 22 Assemble the plastic dosing vessel

3.3.2.2 Glass dosing vessel

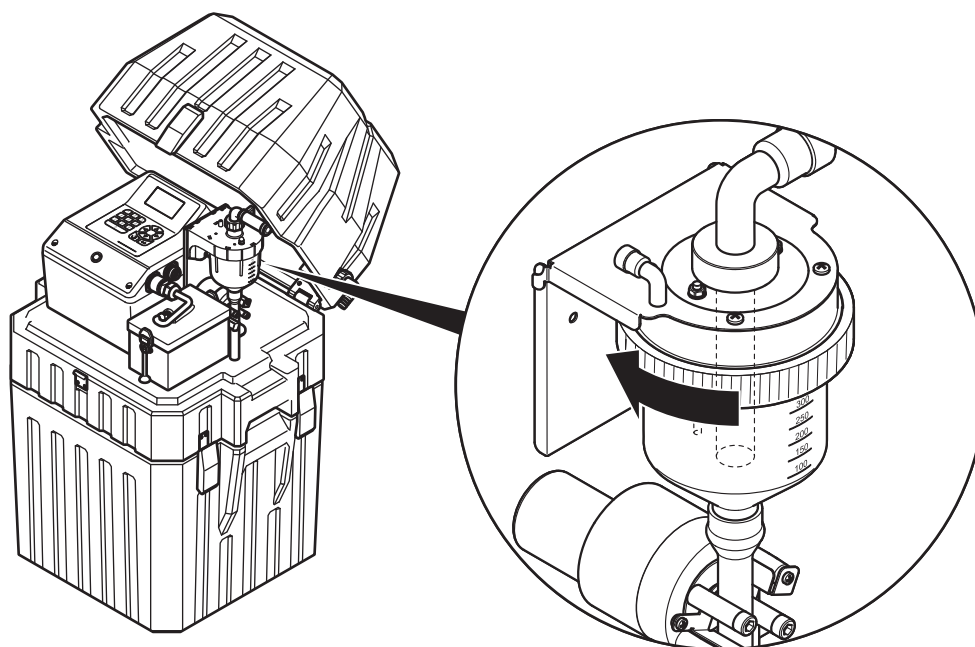

Figure 23 Loosen the union nut on the glass dosing vessel

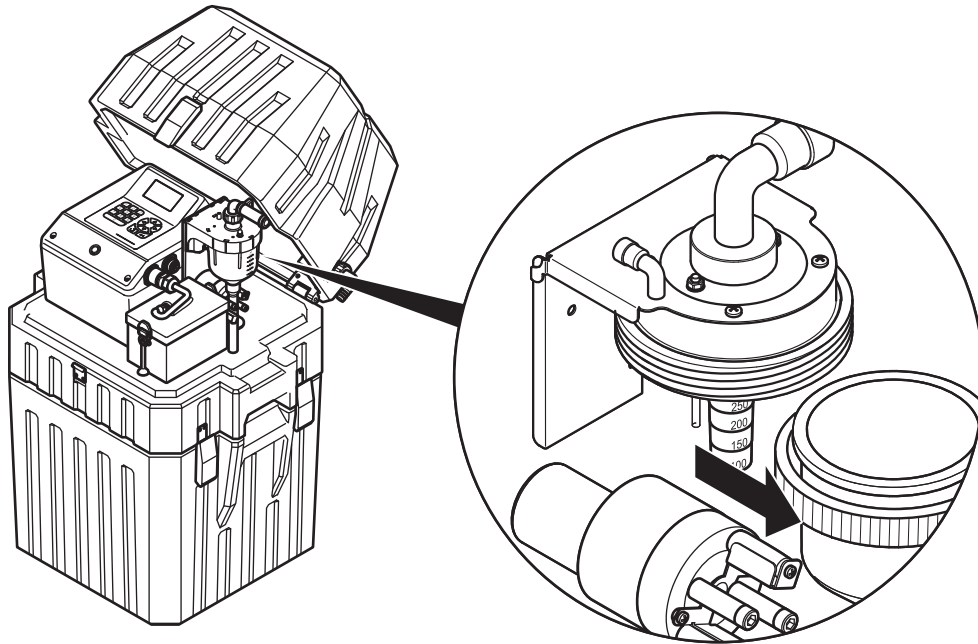

Figure 24 Remove the glass dosing vessel

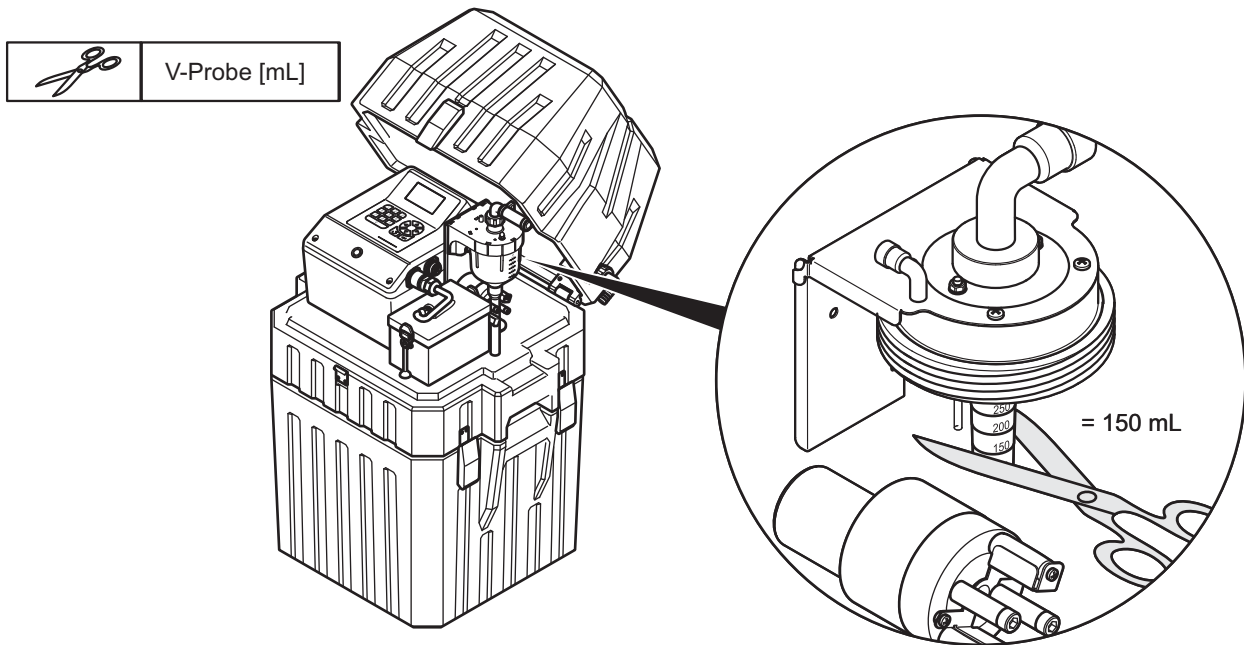

Figure 25 Cut the dosing tube to set the sample volume

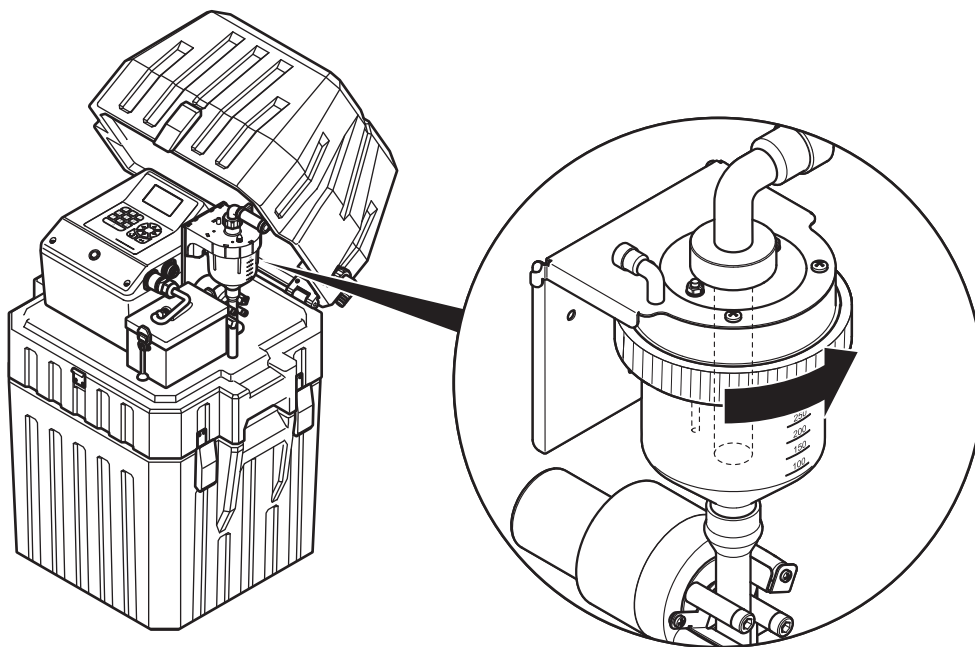

Figure 26 Assemble the glass dosing vessel

3.3.2.3 Dosing vessel for flow-proportional sampling

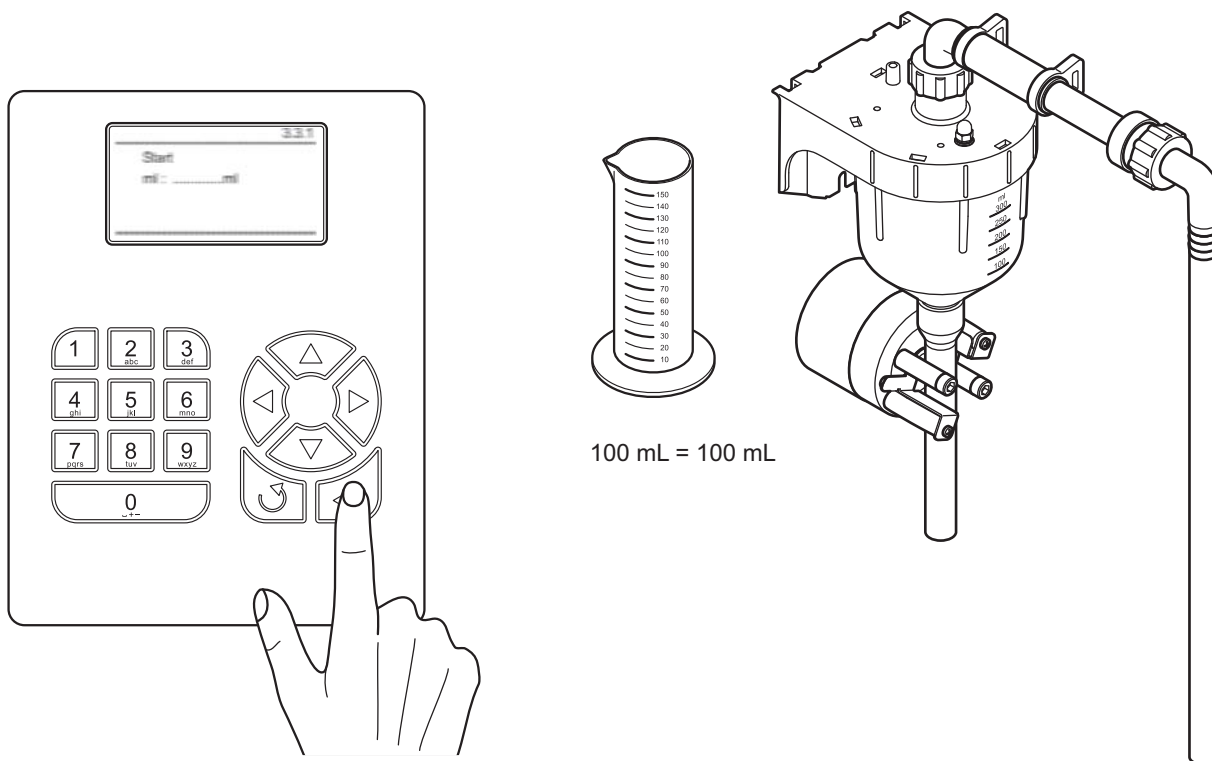

Figure 27 Calibrate the flow-proportional dosing vessel via the service menu

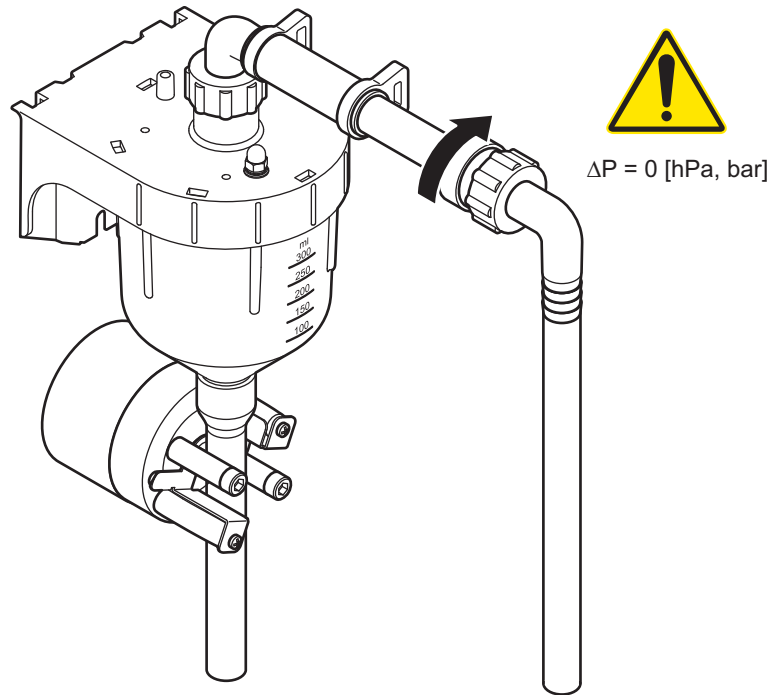

Figure 28 The flow-proportional dosing vessel can only be used, if there is NO counter pressure

3.3.3 Remove the top part of the housing (1029)

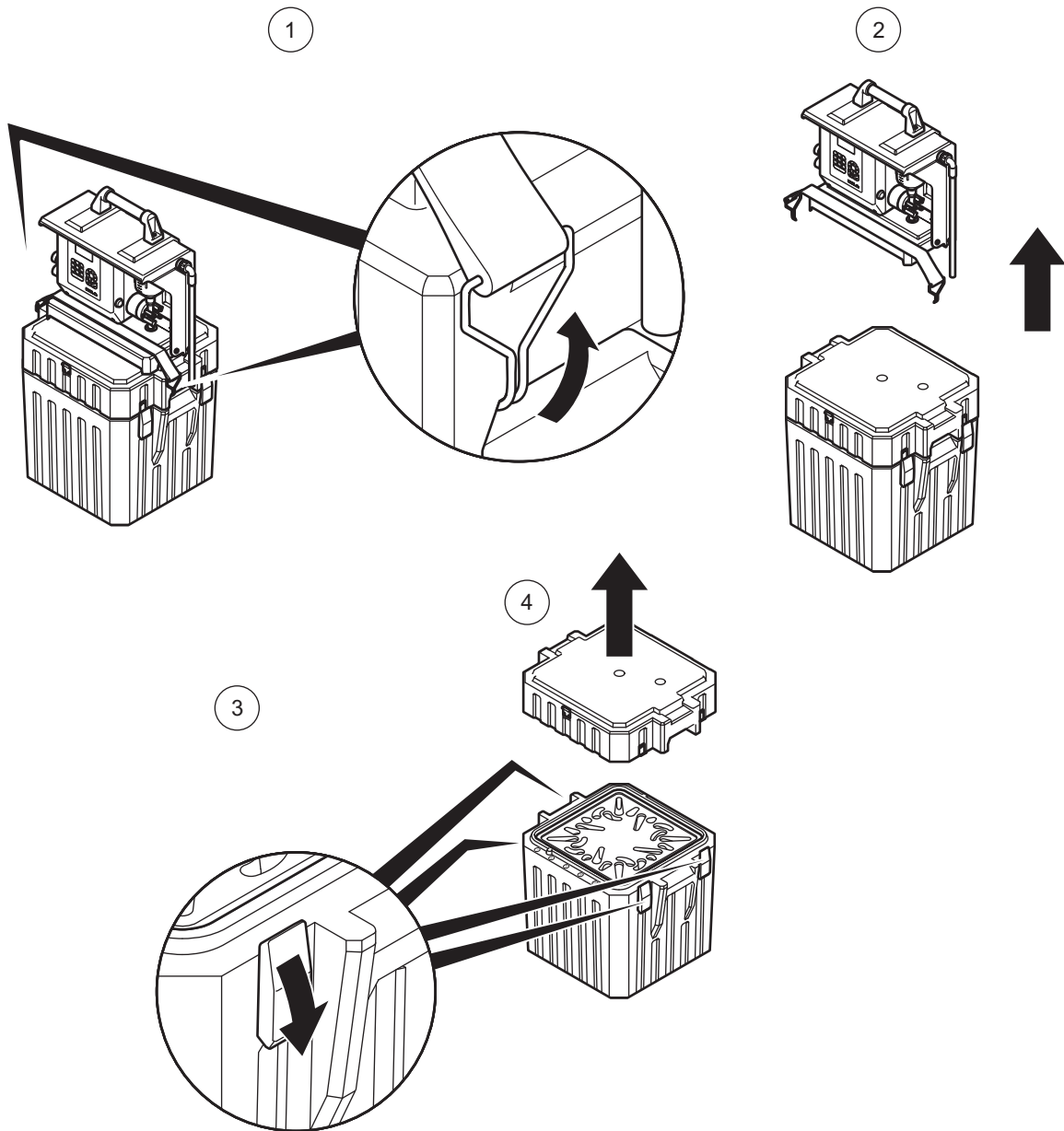

Figure 29 Remove the top part of the housing (1029)

3.3.4 Remove the top part of the housing (2000)

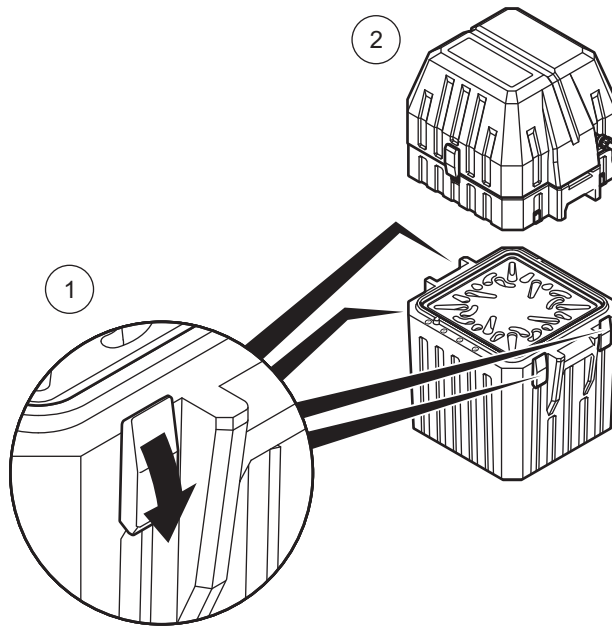

Figure 30 Remove the top part of the housing (2000)

3.3.5 Prepare the bottle compartments

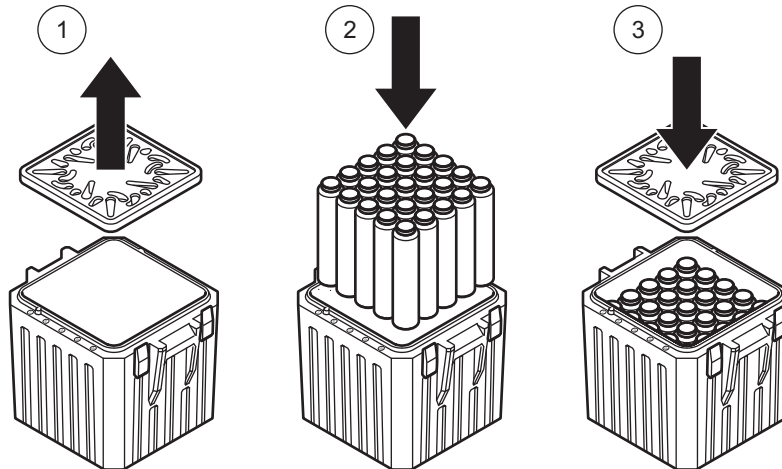

Figure 31 Place the empty bottles into the bottle compartment

Note: The sample distributor plate works correctly in all four of its potential positions.

Note: The housing base of the bottle compartment features numbers so that the individual bottles can be assigned with a number.

3.3.6 Attach the top part of the housing

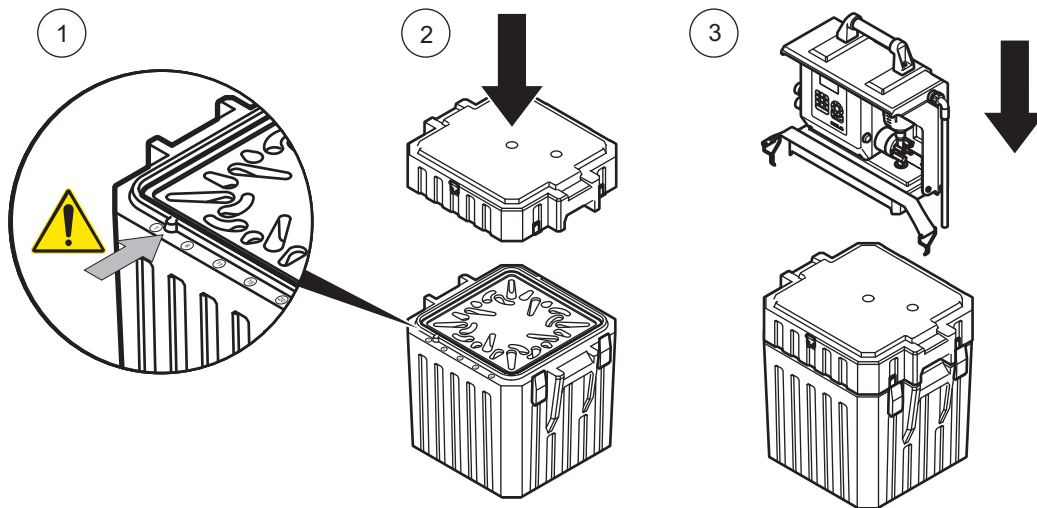

Figure 32 Attach the top part of the housing (1029)

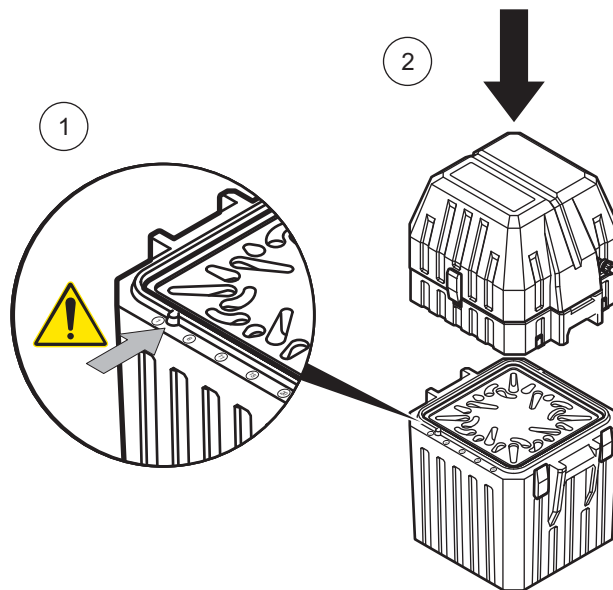

Figure 33 Attach the top part of the housing (2000)

3.3.7 Connect the equipment to the mains

Make sure that:

- The equipment has been fully prepared for commissioning
- The data on the type plate corresponds to the data relating to the mains power supply (this applies to 1027 as well as to 1029 and 2000 in connection with the charger and Y plug BM69742)
- The correct plug has been attached or the direct wire has been implemented correctly
- The equipment can be put into operation without any risks



DANGER

Make sure that the power supply, cable (also refer to [Figure 14, page 18](#)) and equipment are suitable for use with each other.

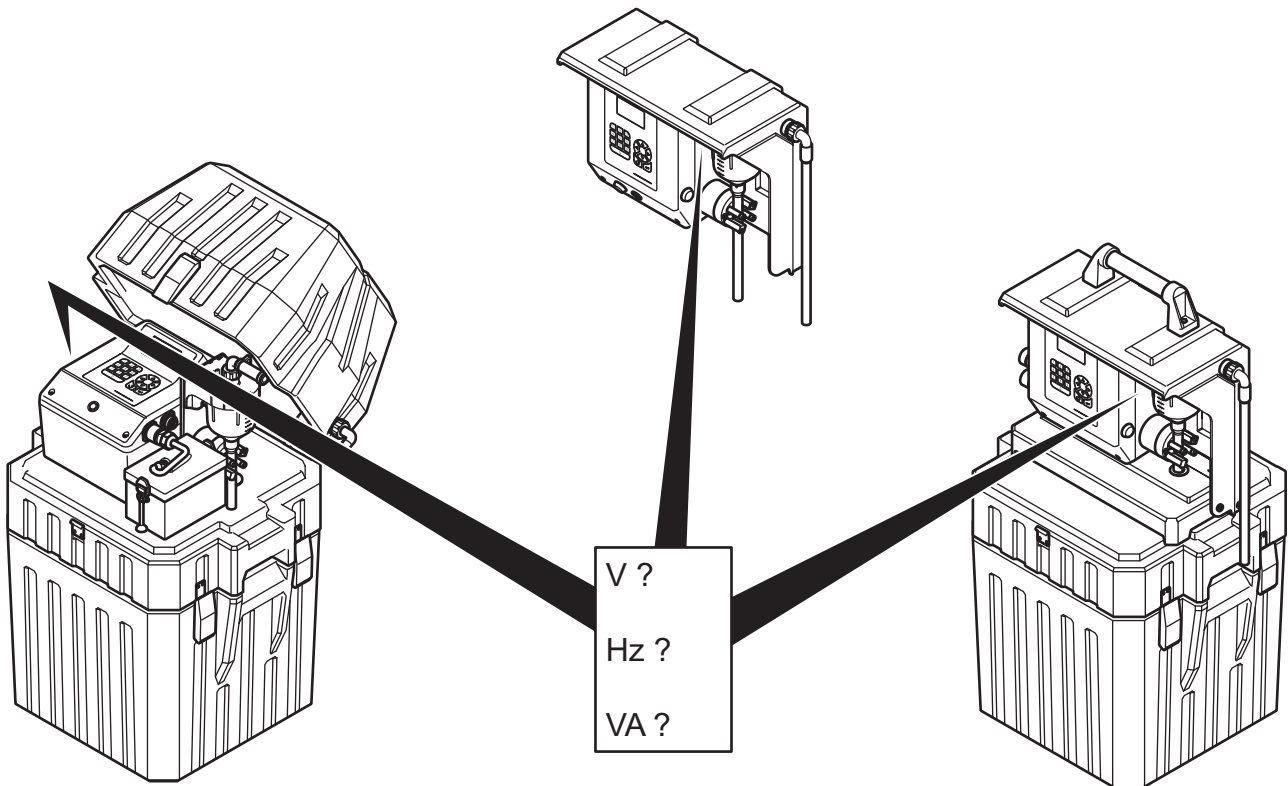

Figure 34 Rating label

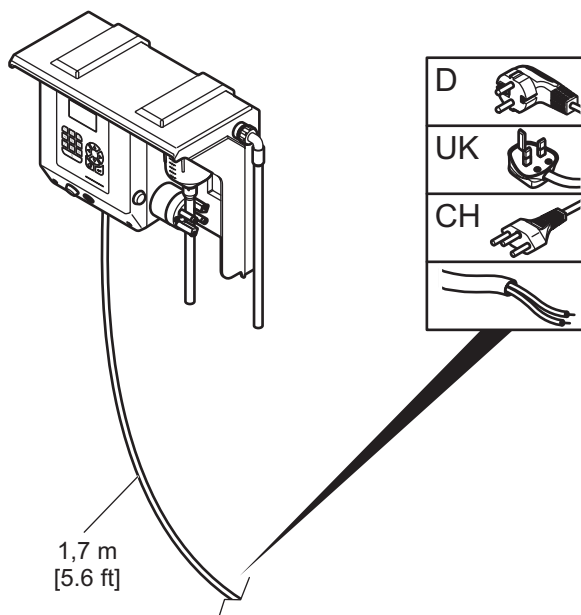

Figure 35 Possible connection configurations (1027)

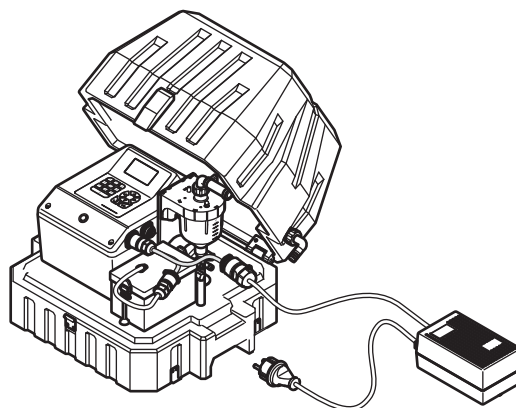

Figure 36 Model 2000 with Y cable and charger

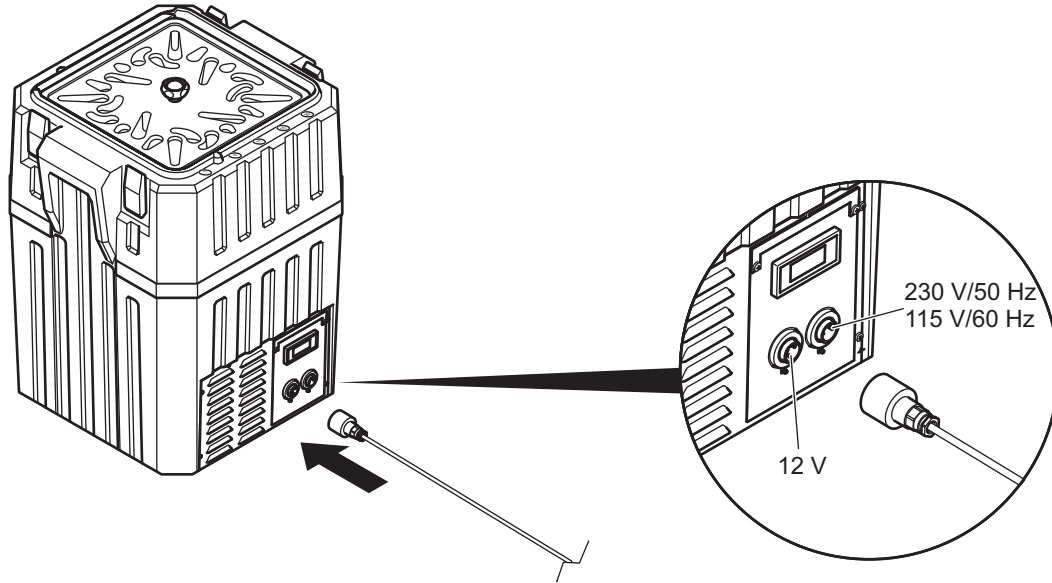

Figure 37 Potential connection variations (optional bottle compartment with active cooling)

3.3.8 Switch on the device

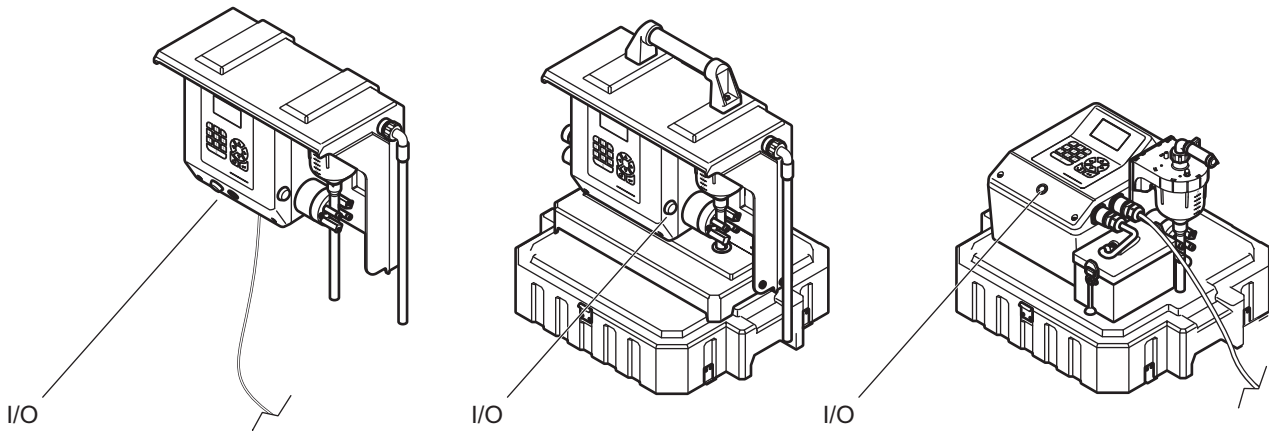

Figure 38 Switch on the device

3.3.9 Adjust the cooling settings for the optional bottle compartment with active cooling (1029 and 2000)

The manufacturer recommends a settings range of +4 to +15 °C.

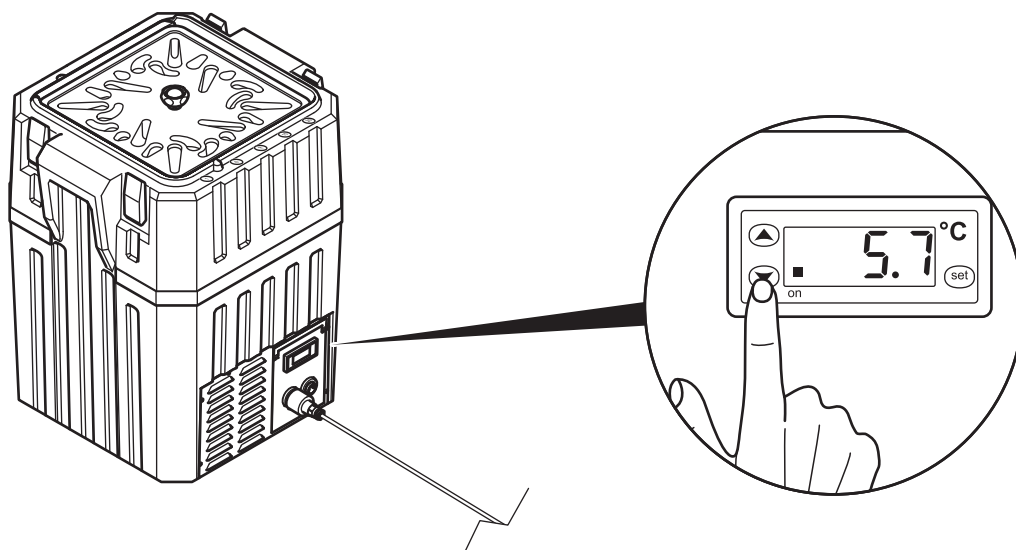

Figure 39 Adjust the cooling settings for the optional bottle compartment with active cooling

Section 4 Operation

4.1 Control unit operation

All the equipment functions are software-controlled.

4.1.1 Password

Password to program sampler and to change settings is:

6299

4.1.2 Programming

The menu structure resembles the directory structure of a computer hard drive and is divided into main menus and sub menus.

4.1.3 Keyboard layout/function

The equipment can be programmed by the operator.

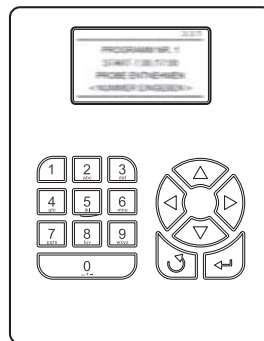



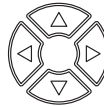



Figure 40 Control panel

The key functions are configured as follows to enable highly intuitive operation:

Table 1 Key functions

Display help text (in the case of selection fields, the cursor must be placed on the left-hand side)	Arrow key	
Move from one menu item to the next menu selection	Arrow keys	
Select the menu required	Enter key	
Move within a menu	Arrow keys	

Table 1 Key functions

Select from within a menu	Arrow keys	
Confirm the selection (automatically marked with a ✓)	Enter key	
Enter/change values	Arrow keys	
Confirm the entered values	Enter key	
Return to the next superordinate menu level	Back key	
Enter values	Numeric keypad	
RESET (restore factory settings) Press and hold Back for at least 10 seconds	Back key	

Example: A setting needs to be changed.

1. Press Enter.
The cursor then flashes.
2. Use the arrow keys to move the cursor until it is in the required position.
3. Press Enter.
The selection is now confirmed and the program can be started.

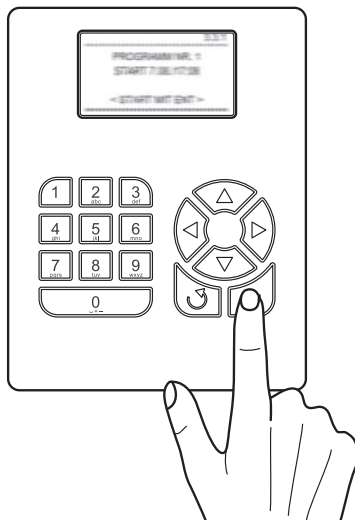

Figure 41 Start the program

Depending on the program range,

- an activity is started or
- the next menu item is automatically selected.

Note: The general rule:

If you press Back,

– the activity is cancelled or

– the navigation takes one step back in the menu.

4.2 Normal operation

4.2.1 Replace the sample bottles

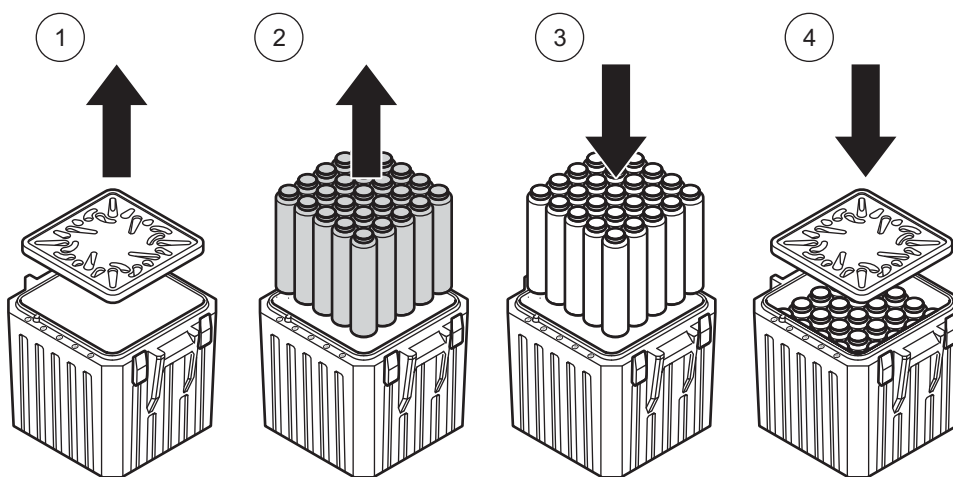

Figure 42 Replace full bottles

Section 5 Maintenance and cleaning



DANGER

Only qualified experts should conduct the tasks described in this section.



WARNING

Please observe the following points for the use of chemicals and/or waste water:

Wear protective clothing:

- Laboratory coat*
 - Protective eyewear*
 - Rubber gloves*
-

5.1 Maintenance tasks

The equipment is maintenance-free, therefore the operator does not need to carry out any maintenance work.

5.2 Cleaning

5.2.1 Clean the housing and distribution unit (1029–2000)



WARNING!

*Manual rotation of the distribution unit can damage the drive.
Never rotate the distribution unit manually.*

Clean the interior and exterior of the housing with a damp, lint-free cloth. Add commercial household cleaner to the cleaning water as required.

1. Clean the exterior of the housing.
2. Remove the top part as shown in the illustrations [Figure 29, Page 27](#) and [Figure 30, Page 28](#).
3. Loosen the central nut and remove the distribution vat.

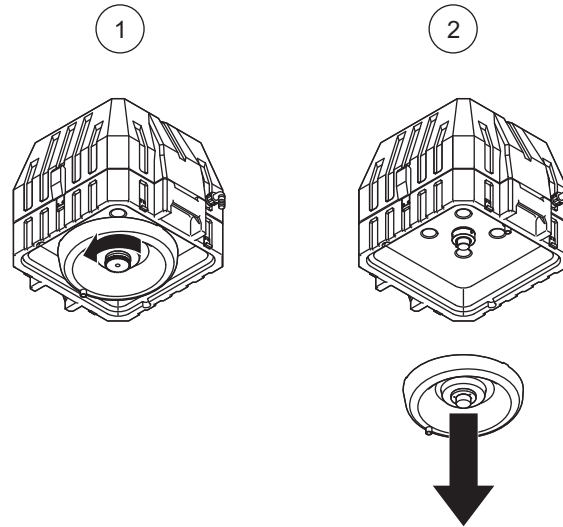

Figure 43 Remove the distribution vat (1029 and 2000)

4. Clean the distribution vat.
5. Attach the distribution vat again and in doing so make sure that the guide pin is positioned in the bore hole.

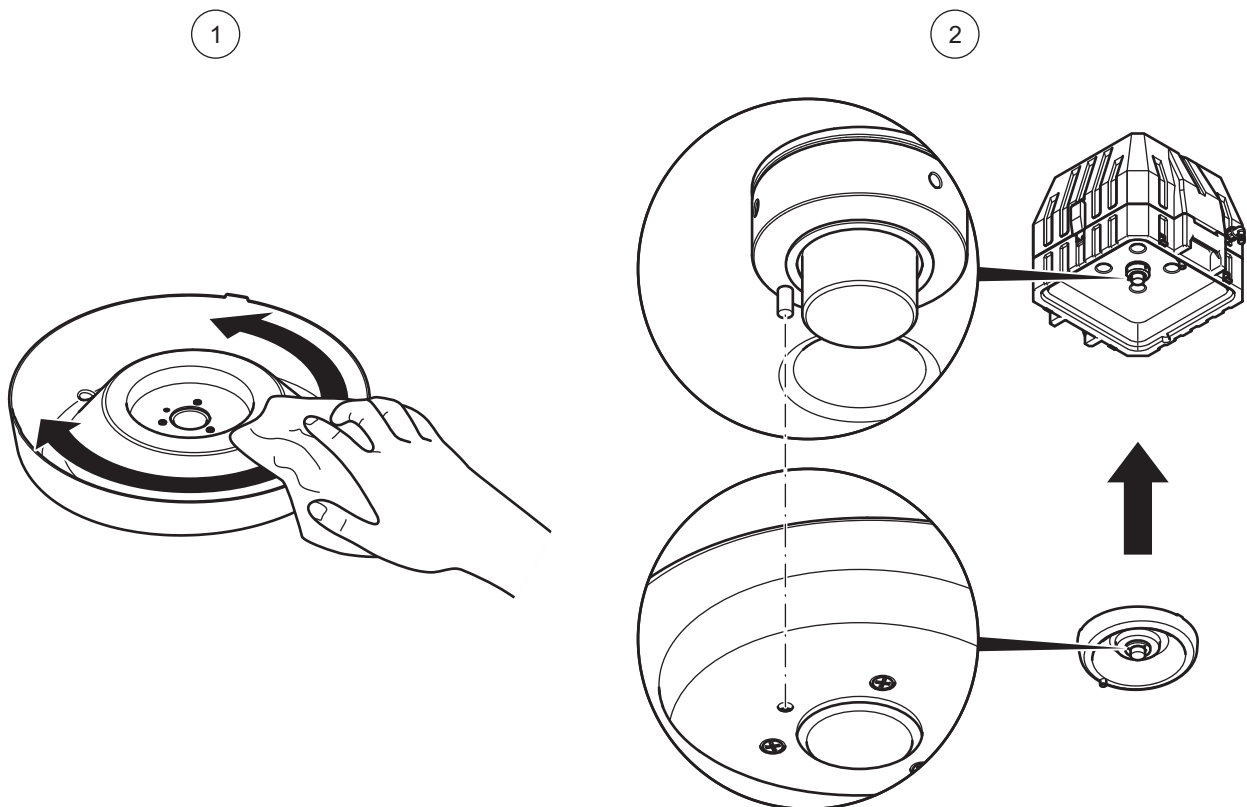

Figure 44 Assemble the distribution vat (1029 and 2000)

6. Tighten the central nut by hand again.

7. Clean the sample distributor plate on the bottle compartment.

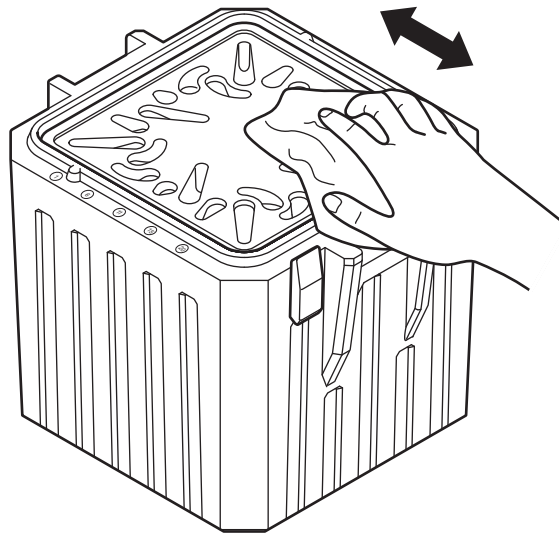

Figure 45 Clean the sample distributor plate on the bottle compartment

8. Position the top part back on the bottle compartment as shown in the illustrations [Figure 32, Page 29](#) and [Figure 33, Page 29](#).

5.2.2 Clean the dosing vessel

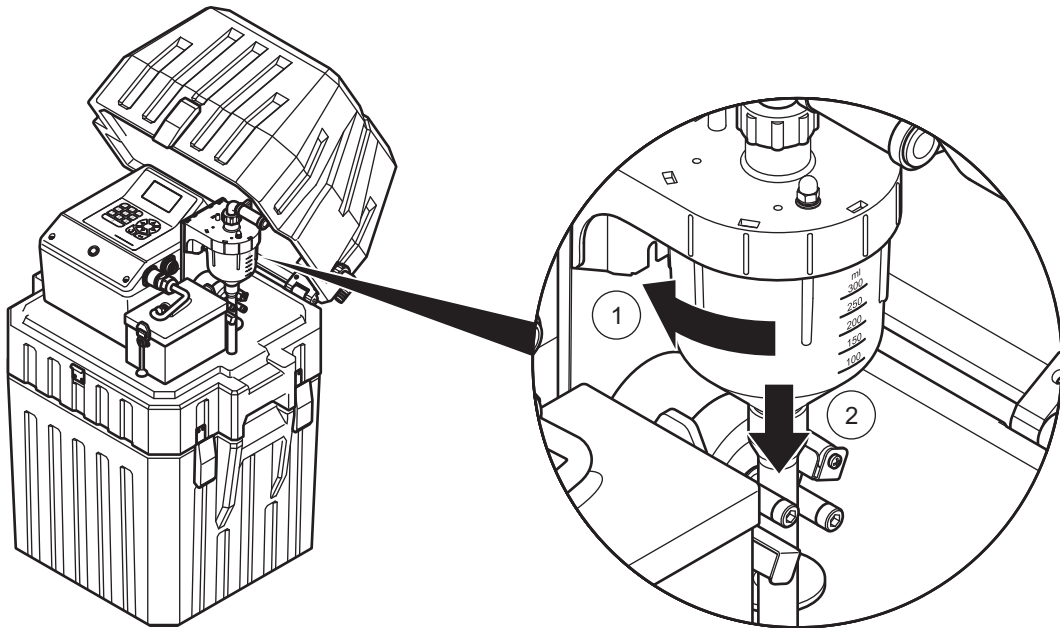

Figure 46 Release the dosing vessel

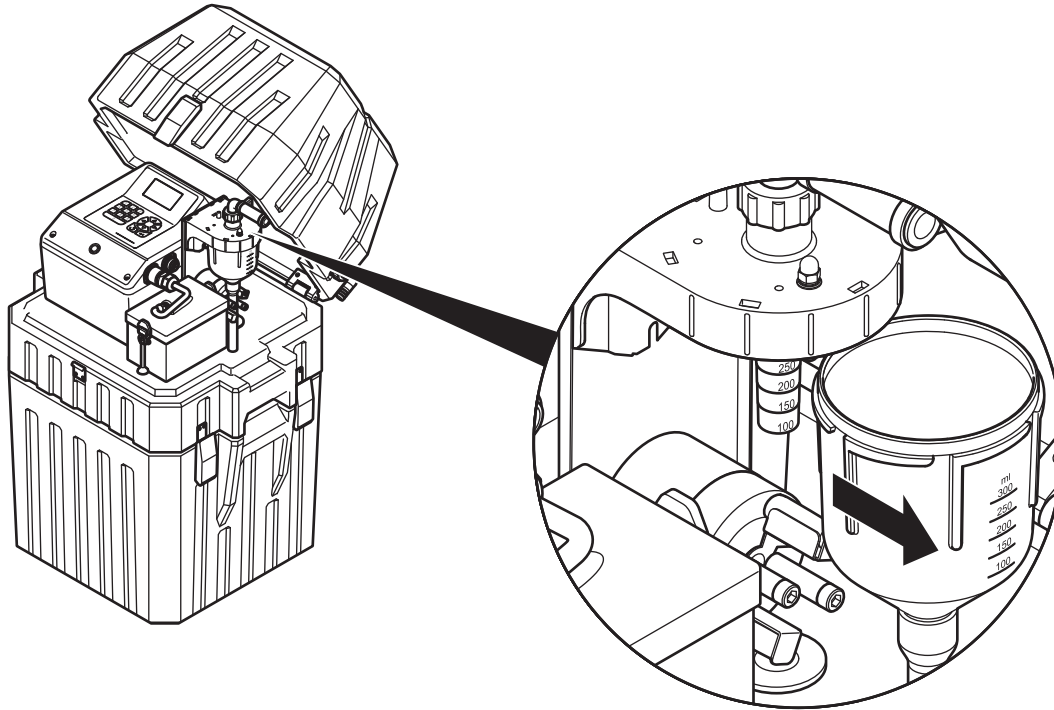

Figure 47 Remove the dosing vessel

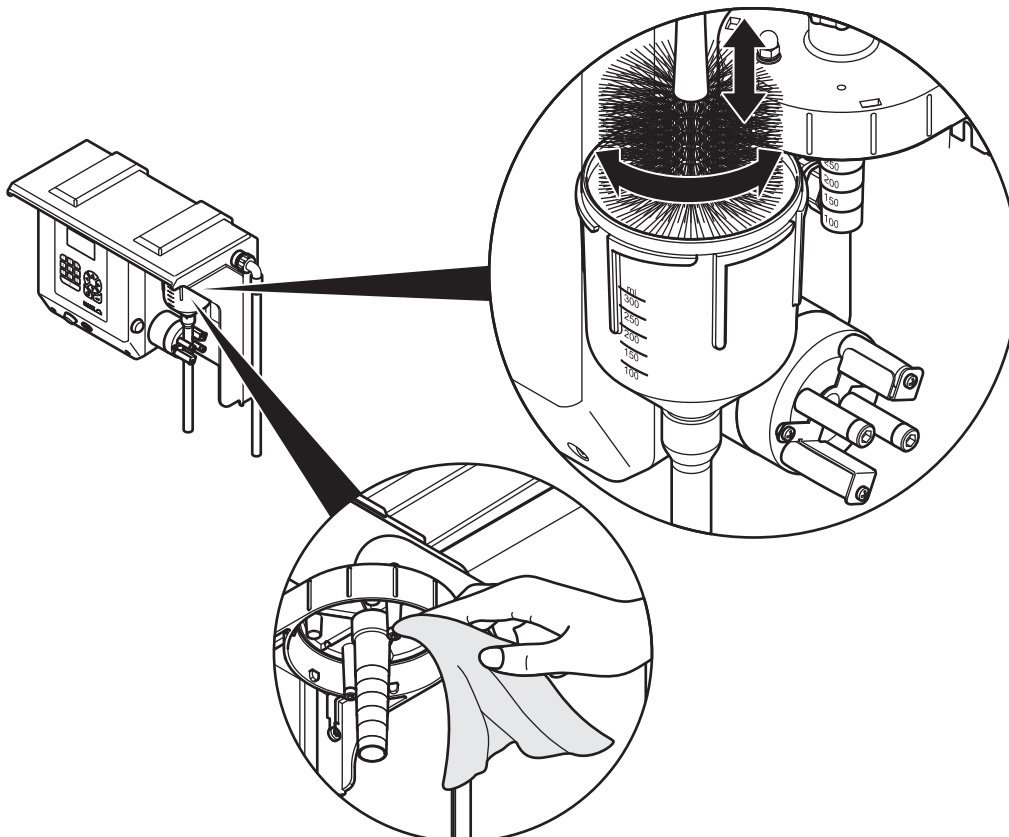

Figure 48 Clean the dosing vessel

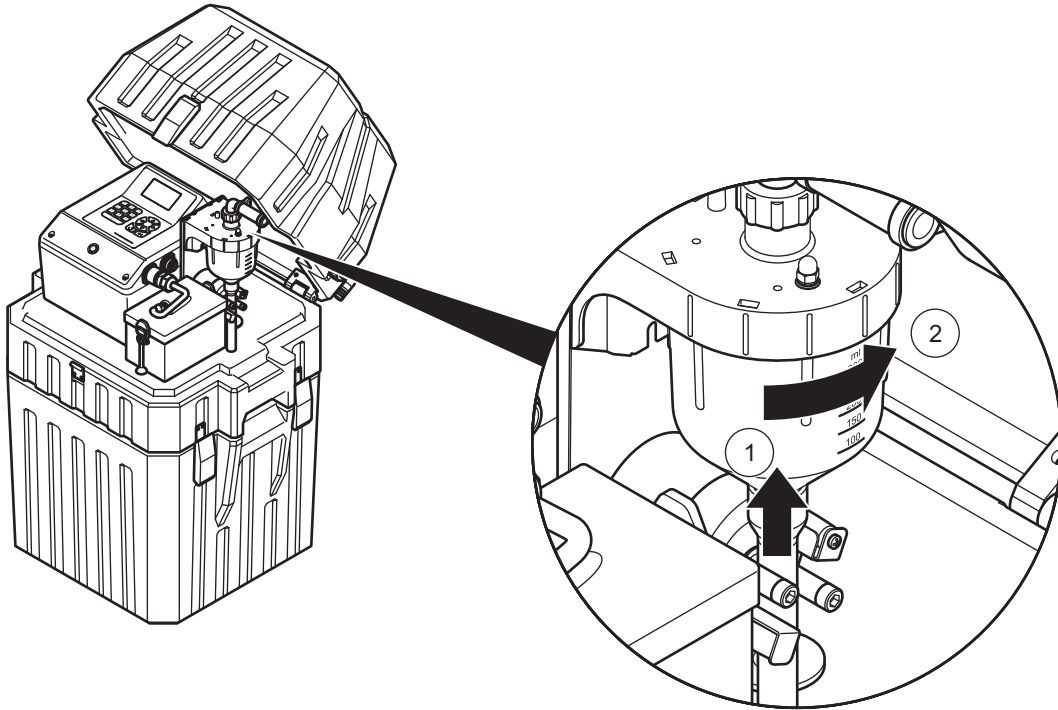

Figure 49 Insert the dosing vessel

5.3 Troubleshooting

If the equipment does not work as required, check the fuse and replace if necessary.

5.3.1 Change the fuse

Open the fuse holder as shown in [Figure 50](#) and replace the defective fuse.

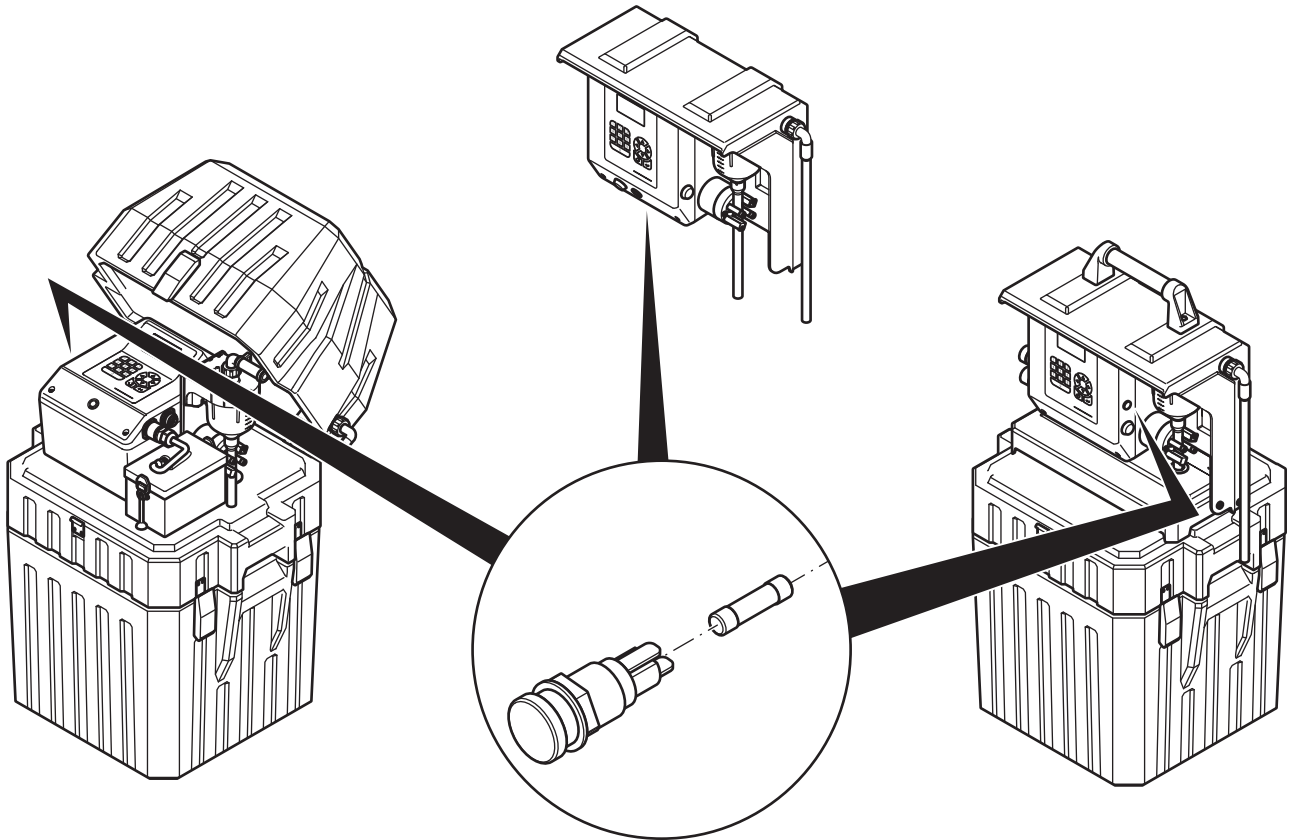

Figure 50 Position of the fuse in the portable sampler

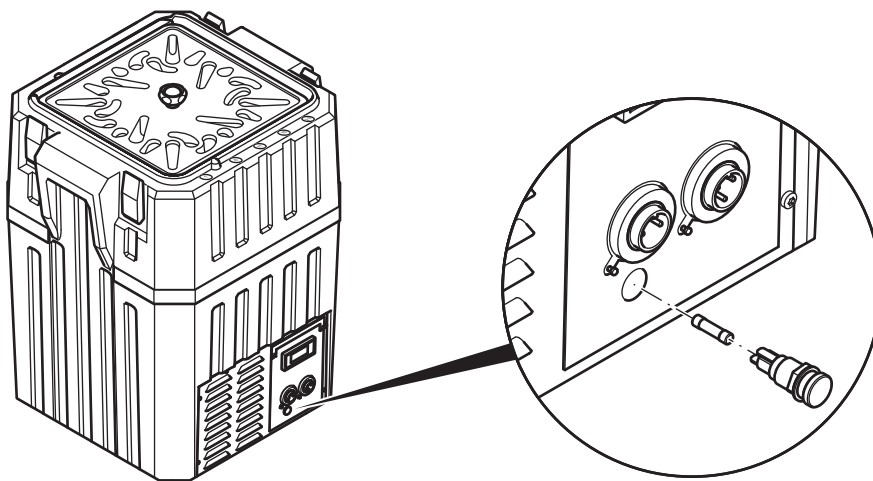

Figure 51 Position of the fuse in the optional bottle compartment with active cooling

If the error is not rectified, please contact the customer service of the manufacturer (refer to [Contact information, page 55](#)).

5.4 Instrument decommissioning and storage

1. Remove all liquids and, if necessary, solid matter from the infeed and outfeed lines and bottle compartments and clean as required.
2. Close all active programs.
3. Switch the equipment off.

Section 6 Replacement parts and accessories

6.1 Spare parts

Description	Cat. no.
Short Manual 1027, 1029, 2000 (xx = language number)	DOC013.xx.90269
Operating instructions 1027 (xx = language number)	DOC023.xx.90152
Operating instructions 1029 and 2000 (xx = language number)	DOC023.xx.90153
Replacement bottle, glass, 1 L	BM30030
Cap for 1 L glass bottle	BM60533
Replacement bottle, glass, 20 L	BM30045
Replacement bottle, PE, 1 L	BM60486
Cap for 1 L PE bottle	BM60488
Replacement bottle, PE, 25 L (with cap)	BM60046
Replacement bottle, PE, 5 L (with cap)	BM60038
Replacement bottle, PE, 13 L (with cap)	BM60045
Replacement battery 1029	BM10012
Replacement battery 2000	BM900116

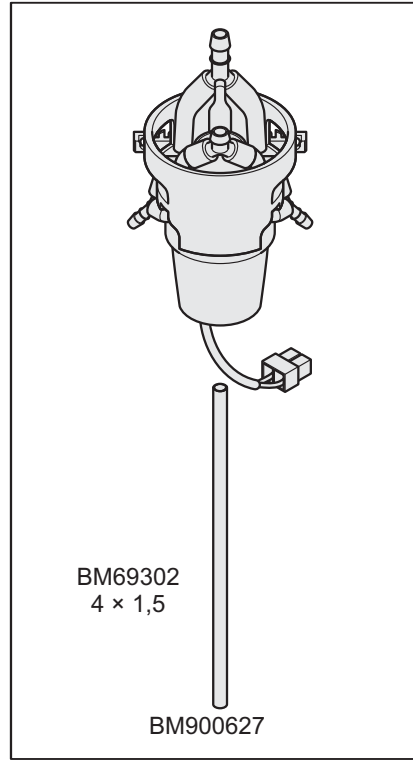
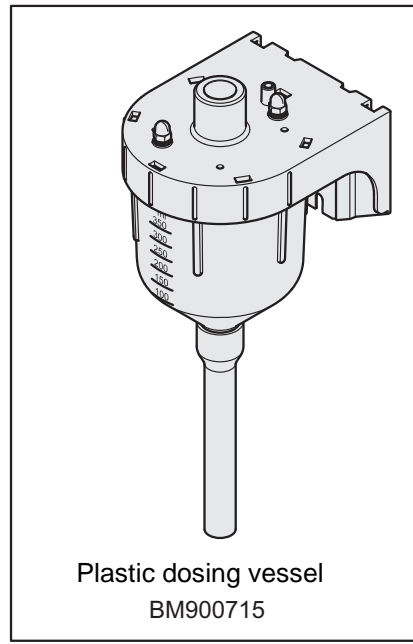
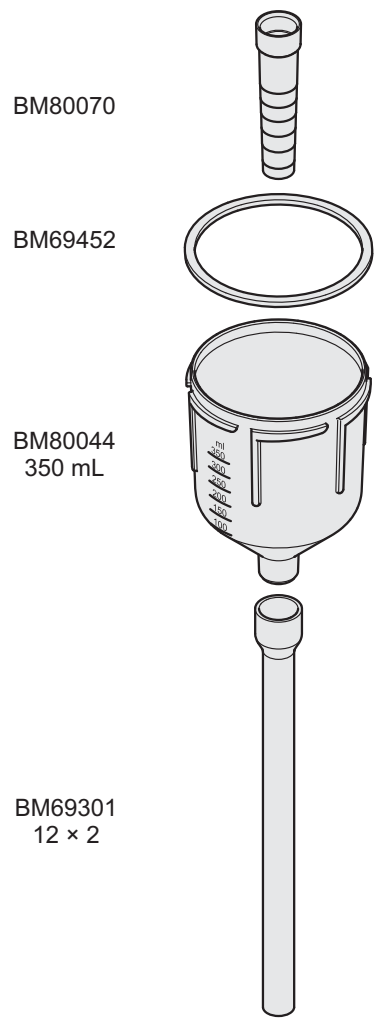

Figure 52 Plastic dosing vessel

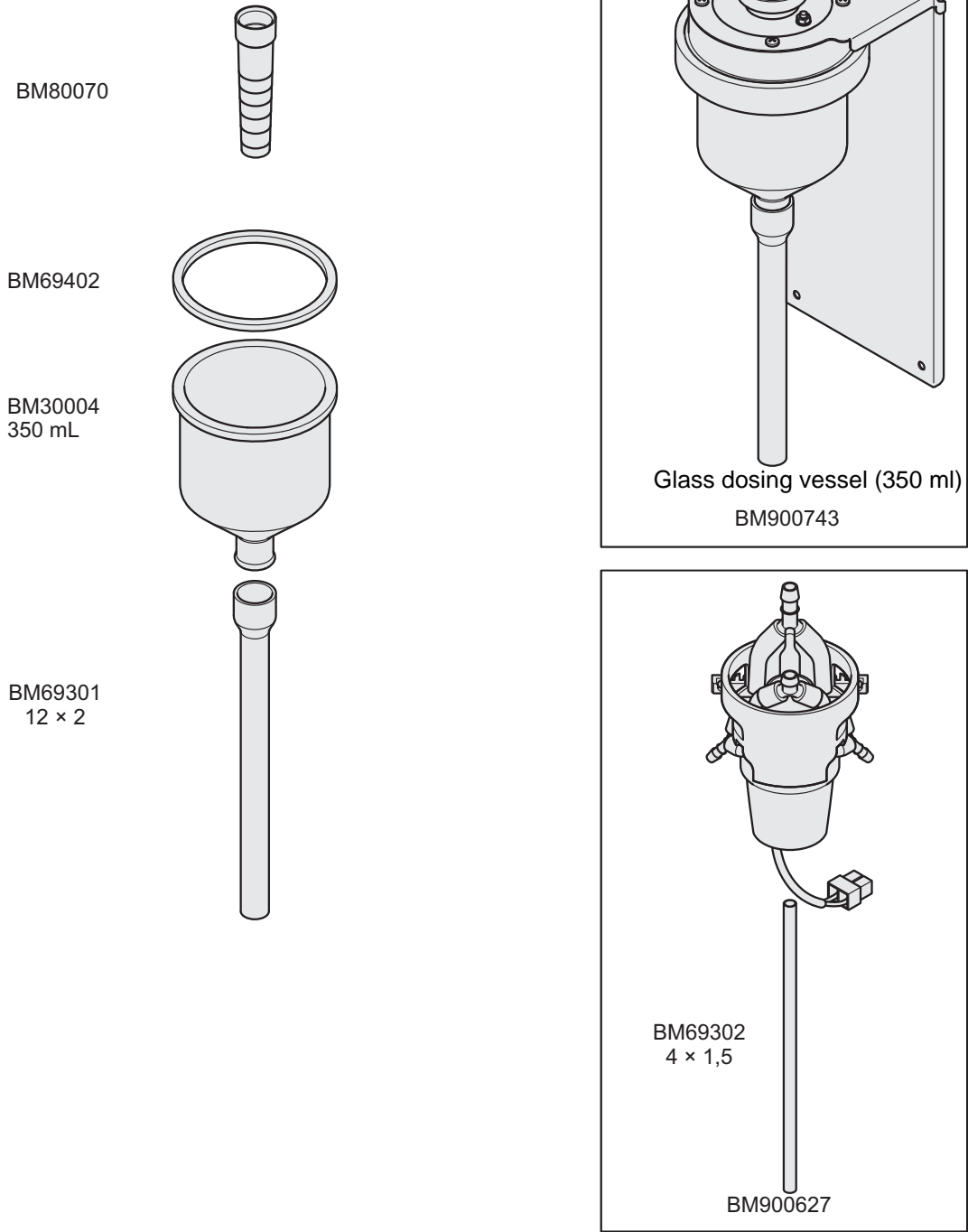

Figure 53 Glass dosing vessel (350 ml)

6.2 Accessories

Description	Cat. no.
Y cable, power supply	BM69742
Charger IP20 for 1029 and 2000	BM900026
Charger IP65 for 1029 and 2000	BM900033
Signal cable, 10 m (32.8 ft.)	BM69644
RS232 serial data cable	BM900021
PC software READ DATA	BM200004
Tube connection with screw connection	BM900300
Battery for bottle compartment with active cooling (90 Ah)	BM10211
Sample transportation box (without bottles)	BM900634
Replacement cooling battery	BM60251
Transportation trolley	BM900802

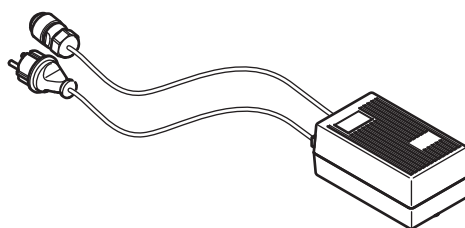

Figure 54 Charger IP20

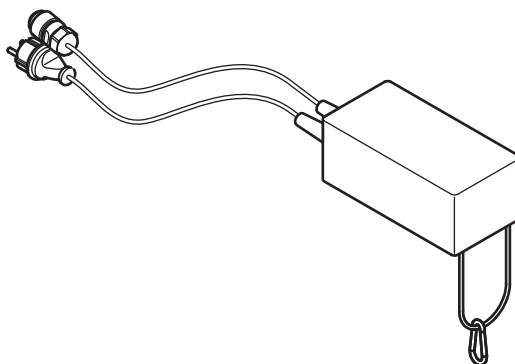

Figure 55 Charger IP65

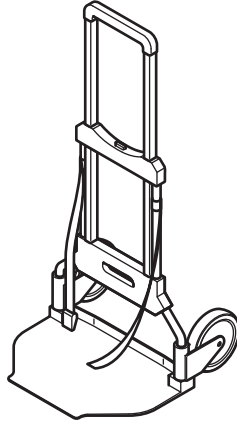

Figure 56 Transportation trolley (1029/2000)

Section 7 **Warranty and Liability**

The manufacturer warrants that the product supplied is free of material and manufacturing defects and undertakes the obligation to repair or replace any defective parts at zero cost.

The warranty period for instruments is 24 months. If a service contract is taken out within 6 months of purchase, the warranty period is extended to 60 months.

With the exclusion of further claims, the supplier is liable for defects including the lack of assured properties as follows: All those parts that, within the warranty period calculated from the day of the transfer of risk, can be demonstrated to have become unusable or that can only be used with significant limitations due to a situation present prior to the transfer of risk, in particular due to incorrect design, poor materials or inadequate finish will be improved or replaced, at the supplier's discretion. The identification of such defects must be reported to the supplier in writing without delay, but no later than 7 days after the identification of the fault. If the customer fails to notify the supplier, the product is considered approved despite the defect. Further liability for any direct or indirect damages is not accepted.

If instrument-specific maintenance and servicing work defined by the supplier is to be performed within the warranty period by the customer (maintenance) or by the supplier (servicing) and these requirements are not carried out, claims for damages due to the failure to comply with the requirements are rendered void.

Any further claims, in particular claims for consequential damages, cannot be made.

Consumables and damage caused by improper handling, unsafe assembly or by incorrect use are excluded from this provision.

Process instruments of the manufacturer are of proven reliability in many applications and are therefore often used in automatic control loops to provide the most economical operation possible for the related process.

To avoid or limit consequential damage, it is therefore recommended to design the control loop such that a malfunction in an instrument results in an automatic change over to the backup control system, which is the most secure operating condition for the environment and for the process.

Section 8 Contact information

HACH Company World Headquarters

P.O. Box 389
Loveland, Colorado
80539-0389 U.S.A.
Tel (800) 227-HACH
(800) -227-4224
(U.S.A. only)
Fax (970) 669-2932
orders@hach.com
www.hach.com

HACH LANGE GMBH

Willstätterstraße 11
D-40549 Düsseldorf
Tel. +49 (0)2 11 52 88-320
Fax +49 (0)2 11 52 88-210
info@hach-lange.de
www.hach-lange.de

HACH LANGE GMBH

Rorschacherstrasse 30a
CH-9424 Rheineck
Tel. +41 (0)848 55 66 99
Fax +41 (0)71 886 91 66
info@hach-lange.ch
www.hach-lange.ch

HACH LANGE APS

Åkandevvej 21
DK-2700 Brønshøj
Tel. +45 36 77 29 11
Fax +45 36 77 49 11
info@hach-lange.dk
www.hach-lange.dk

HACH LANGE LDA

Av. do Forte nº8
Fracção M
P-2790-072 Carnaxide
Tel. +351 214 253 420
Fax +351 214 253 429
info@hach-lange.pt
www.hach-lange.pt

HACH LANGE KFT.

Vöröskereszt utca. 8-10.
H-1222 Budapest XXII. ker.
Tel. +36 1 225 7783
Fax +36 1 225 7784
info@hach-lange.hu
www.hach-lange.hu

Repair Service in the United States:

HACH Company
Ames Service
100 Dayton Avenue
Ames, Iowa 50010
Tel (800) 227-4224
(U.S.A. only)
Fax (515) 232-3835

HACH LANGE LTD

Pacific Way
Salford
GB-Manchester, M50 1DL
Tel. +44 (0)161 872 14 87
Fax +44 (0)161 848 73 24
info@hach-lange.co.uk
www.hach-lange.co.uk

HACH LANGE FRANCE S.A.S.

8, mail Barthélémy Thimonnier
Lognes
F-77437 Marne-La-Vallée
cedex 2
Tél. +33 (0) 820 20 14 14
Fax +33 (0)1 69 67 34 99
info@hach-lange.fr
www.hach-lange.fr

HACH LANGE AB

Vinthundsvägen 159A
SE-128 62 Sköndal
Tel. +46 (0)8 7 98 05 00
Fax +46 (0)8 7 98 05 30
info@hach-lange.se
www.hach-lange.se

HACH LANGE SP. ZO.O.

ul. Krakowska 119
PL-50-428 Wrocław
Tel. +48 801 022 442
Fax +48 717 174 088
info@hach-lange.pl
www.hach-lange.pl

HACH LANGE S.R.L.

Str. Căminului nr. 3,
et. 1, ap. 1, Sector 2
RO-021741 București
Tel. +40 (0) 21 205 30 03
Fax +40 (0) 21 205 30 17
info@hach-lange.ro
www.hach-lange.ro

Repair Service in Canada:

Hach Sales & Service
Canada Ltd.
1313 Border Street, Unit 34
Winnipeg, Manitoba
R3H 0X4
Tel (800) 665-7635
(Canada only)
Tel (204) 632-5598
Fax (204) 694-5134
canada@hach.com

HACH LANGE LTD

Unit 1, Chestnut Road
Western Industrial Estate
IRL-Dublin 12
Tel. +353(0)1 460 2522
Fax +353(0)1 450 9337
info@hach-lange.ie
www.hach-lange.ie

HACH LANGE NV/SA

Motstraat 54
B-2800 Mechelen
Tel. +32 (0)15 42 35 00
Fax +32 (0)15 41 61 20
info@hach-lange.be
www.hach-lange.be

HACH LANGE S.R.L.

Via Rossini, 1/A
I-20020 Lainate (MI)
Tel. +39 02 93 575 400
Fax +39 02 93 575 401
info@hach-lange.it
www.hach-lange.it

HACH LANGE S.R.O.

Zastrčená 1278/8
CZ-141 00 Praha 4 - Chodov
Tel. +420 272 12 45 45
Fax +420 272 12 45 46
info@hach-lange.cz
www.hach-lange.cz

HACH LANGE

8, Kr. Sarafov str.
BG-1164 Sofia
Tel. +359 (0)2 963 44 54
Fax +359 (0)2 866 15 26
info@hach-lange.bg
www.hach-lange.bg

Repair Service in Latin America, the Caribbean, the Far East, Indian Subcontinent, Africa, Europe, or the Middle East:

Hach Company World
Headquarters,
P.O. Box 389
Loveland, Colorado,
80539-0389 U.S.A.
Tel +001 (970) 669-3050
Fax +001 (970) 669-2932
intl@hach.com

HACH LANGE GMBH

Hütteldorfer Str. 299/Top 6
A-1140 Wien
Tel. +43 (0)1 912 16 92
Fax +43 (0)1 912 16 92-99
info@hach-lange.at
www.hach-lange.at

DR. LANGE NEDERLAND B.V.

Laan van Westroijen 2a
NL-4003 AZ Tiel
Tel. +31(0)344 63 11 30
Fax +31(0)344 63 11 50
info@hach-lange.nl
www.hach-lange.nl

HACH LANGE S.L.U.

Edificio Seminario
C/Larrauri, 1C- 2ª Pl.
E-48160 Derio/Vizcaya
Tel. +34 94 657 33 88
Fax +34 94 657 33 97
info@hach-lange.es
www.hach-lange.es

HACH LANGE S.R.O.

Roľnícka 21
SK-831 07 Bratislava –
Vajnory
Tel. +421 (0)2 4820 9091
Fax +421 (0)2 4820 9093
info@hach-lange.sk
www.hach-lange.sk

HACH LANGE SU ANALİZ SISTEMLERİ LTD.ŞTİ.

İlkbahar mah. Galip Erdem
Cad. 616 Sok. No:9
TR-Oran-Çankaya/ANKARA
Tel. +90312 4908300 Ext. 140
Fax +90312 4919903
bilgi@hach-lange.com.tr
www.hach-lange.com.tr

Contact information

HACH LANGE D.O.O.

Fajfarjeva 15
SI-1230 Domžale
Tel. +386 (0)59 051 000
Fax +386 (0)59 051 010
info@hach-lange.si
www.hach-lange.si

HACH LANGE E.Π.Ε.

Αυλίδος 27
GR-115 27 Αθήνα
Τηλ. +30 210 7777038
Fax +30 210 7777976
info@hach-lange.gr
www.hach-lange.gr

HACH LANGE D.O.O.

Ivana Severa bb
HR-42 000 Varaždin
Tel. +385 (0) 42 305 086
Fax +385 (0) 42 305 087
info@hach-lange.hr
www.hach-lange.hr

HACH LANGE MAROC SARLAU

Villa 14 – Rue 2 Casa
Plaisance
Quartier Racine Extension
MA-Casablanca 20000
Tél. +212 (0)522 97 95 75
Fax +212 (0)522 36 89 34
info-maroc@hach-lange.com
www.hach-lange.ma