



DOC022.53.80603

MEL MF Total Coliform Laboratory

Procedures Manual

10/2025, Edition 2

| | |
|---|----|
| Section 1 General information | 3 |
| 1.1 Safety information..... | 3 |
| 1.2 Use of hazard information..... | 3 |
| 1.3 Product overview..... | 3 |
| 1.4 Product components..... | 4 |
| Section 2 Bacteria analysis | 5 |
| 2.1 About indicator organisms..... | 5 |
| 2.2 Presumptive and confirmation procedures..... | 5 |
| 2.3 Preparation for bacteria tests..... | 5 |
| 2.3.1 Prepare the work area..... | 5 |
| 2.3.2 Sterilize laboratory equipment..... | 5 |
| 2.4 Sample collection and preservation..... | 6 |
| 2.5 Sample volumes..... | 7 |
| 2.6 Sterile buffered dilution water..... | 8 |
| 2.7 Serial sample dilutions..... | 8 |
| 2.8 Interpret and report the coliform results..... | 9 |
| 2.9 Enrichment procedure for stressed bacteria..... | 10 |
| 2.10 Controls for coliform bacteria tests..... | 10 |
| 2.11 Bacteria disposal..... | 10 |
| Section 3 Microbiological Procedures | 11 |
| Coliforms, Total, Fecal and E. coli, m-Endo..... | 13 |
| Coliforms, Fecal, m-FC and m-FC/RA..... | 23 |
| Coliforms, E. coli, modified m-TEC..... | 29 |

Section 1 General information

In no event will the manufacturer be liable for direct, indirect, special, incidental or consequential damages resulting from any defect or omission in this manual unless otherwise required by applicable law or contract between the parties. The manufacturer reserves the right to make changes in this manual and the products it describes at any time, without notice or obligation. Revised editions are found on the manufacturer's website.

1.1 Safety information

The manufacturer is not responsible for any damages due to misapplication or misuse of this product including, without limitation, direct, incidental and consequential damages, and disclaims such damages to the full extent permitted under applicable law. The user is solely responsible to identify critical application risks and install appropriate mechanisms to protect processes during a possible equipment malfunction.

Please read this entire manual before unpacking, setting up or operating this equipment. Pay attention to all danger and caution statements. Failure to do so could result in serious injury to the operator or damage to the equipment.

If the equipment is used in a manner that is not specified by the manufacturer, the protection provided by the equipment may be impaired. Do not use or install this equipment in any manner other than that specified in this manual.

1.2 Use of hazard information

| |
|--|
| ⚠ DANGER |
| Indicates a potentially or imminently hazardous situation which, if not avoided, will result in death or serious injury. |
| ⚠ WARNING |
| Indicates a potentially or imminently hazardous situation which, if not avoided, could result in death or serious injury. |
| ⚠ CAUTION |
| Indicates a potentially hazardous situation that may result in minor or moderate injury. |
| NOTICE |
| Indicates a situation which, if not avoided, may cause damage to the instrument. Information that requires special emphasis. |

1.3 Product overview

The MEL MF (Membrane Filtration) Laboratory is a portable test kit for coliform and *E. coli* bacteria in water samples.

In the MF method of analysis, the sample goes through a membrane filter and the bacteria stays on the membrane filter. The membrane filter is incubated in a petri dish with nutritional media that helps coliform bacteria grow. The user counts the bacteria colonies that show on the membrane filter to make an estimate of the bacterial population in the water.

The MF Method is especially useful for drinking water samples because large numbers of samples can be analyzed in a short time.

The required media are not included in the MEL MF Laboratory. Refer to the consumables and replacement items section of the test procedures to find the media for

General information

the applicable test. Make sure to get confirmation media for positive samples and dilution water for wastewater samples.

Refer to the Portable Incubator user manual for operation of the Portable Incubator. Refer to Product Components and the Packaging Guide to assemble the components in the carrying case.

1.4 Product components

Make sure that all components have been received. Refer to the list that follows. If any items are missing or damaged, contact the manufacturer or a sales representative immediately.

- Alcohol burner
- Bag, polyethylene, 9 x 14 inch (2x)
- Counter, hand tally
- Forceps
- Funnel assembly with filter, pad, petri dish (200x)
- Manifold, field vacuum
- Carrying case
- Portable incubator with 12 VDC power socket
- Incubator rack for petri dishes
- Sampling bags, Whirl-Pak with dechlorinating agent, 180 mL (200x)
- Laboratory marker
- Syringe, 140 mL
- Thermometer, pocket, -10 to 110 °C (14 to 230 °F)
- Tubing, 3/8 inch OD, 5 ft

Section 2 Bacteria analysis

The amount and type of bacteria in water samples is routinely measured to find whether the water contains disease-causing organisms. All tests for bacteria use a nutritional broth or agar and incubation at a specific temperature to grow the target organism. Sterile equipment and careful handling techniques are necessary to prevent contamination of the sample.

2.1 About indicator organisms

Bacterial pathogens that cause serious diseases are difficult to detect in water supplies and include long and complex test procedures. Thus, tests for indicator organisms that have a fecal origin such as coliform bacteria are commonly used. Indicator organisms may not be pathogenic but are present when pathogens are present and absent when pathogens are absent.

Total coliform bacteria are commonly used as indicator organisms in potable water supplies in temperate climates. Fecal coliform bacteria, and more specifically *Escherichia coli*, are commonly used as indicator organisms for non-potable water, wastewater, bathing water and swimming water.

In tropical climates, indigenous *Escherichia coli* (*E. coli*) bacteria give positive results in total coliform tests even in clean water sources where no fecal contamination exists. Thus, other bacteria that are associated with fecal contamination, such as hydrogen sulfide-producing bacteria, are used as an indicator organism.

2.2 Presumptive and confirmation procedures

Most test methods for bacteria begin with a presumptive test procedure. If the result from the presumptive test is positive, a confirmation procedure must be completed. Some media is selective for the target organism and a confirmation test is not required. For example, the m-ColiBlue24[®] broth and broth that contains MUG is selective for *E. coli*.

- Presumptive test—a positive result is an indication of the target organism but can include a false positive result.
- Confirmation test—the cultured bacteria from the presumptive test are used to inoculate the confirmation media. The confirmation media is more selective for the target organism and may use a higher incubation temperature.

2.3 Preparation for bacteria tests

Good laboratory technique is necessary for bacteria tests. To make sure that the results are reliable, collect and preserve samples carefully. Use high-quality laboratory equipment and ready-to-use media to save time and prevent errors.

2.3.1 Prepare the work area

- Wash hands thoroughly with soap and water.
- Disinfect the work bench with a germicidal cloth, dilute bleach solution, bactericidal spray or dilute iodine solution. A small propane torch can be used to flame-sterilize metal faucets that are used for sample collection.
- Set the incubator to the temperature that is specified by the test procedure. Typically 35 ± 0.5 °C (95 ± 0.9 °F) is used for total coliforms and enterococci and 44.5 ± 0.2 °C (112.1 ± 0.4 °F) is used for fecal coliforms.

2.3.2 Sterilize laboratory equipment

All materials that are used to contain or transfer samples must be sterile to prevent contamination and false results. Use pre-sterilized, disposable laboratory equipment and media to save time and minimize errors. When numerous analyses must be completed on a routine basis, sterilization of non-disposable materials with an autoclave is recommended.

1. Wash sample containers and any necessary equipment with hot water and detergent. Some procedures use equipment such as pipets, petri dishes, a filter holder with stopper and a graduated cylinder.
2. Rinse containers and equipment several times with tap water and then with deionized water.
3. If the water to be sampled has been disinfected by some entity before collection, add the contents of one Dechlorinating Reagent Powder Pillow for each 125 mL of container volume (for 250-mL sample containers, use two powder pillows.)
4. Prepare all equipment for the autoclave as follows:
 - a. Loosely install the caps on sample bottles and put foil or paper on caps and bottle necks.
 - b. Put foil or paper over the openings of graduated cylinders.
 - c. Insert the filter funnel base into an autoclavable rubber stopper that will fit the filter flask.
 - d. Put heavy wrapping paper around the two parts of the filter funnel assembly and seal with masking tape.
 - e. Put paper around petri dishes (borosilicate glass) or put in aluminum or stainless steel cans.
5. Put the containers and equipment in the autoclave. Steam sterilize the containers and equipment at 121 °C (250 °F) for 15 minutes. Glass sample containers can be sterilized with hot air at 170 °C (338° F) for 1 hour.
6. When sterilization is complete, put on sterile gloves and tighten the caps on the containers and equipment. Put the labware in a clean environment until needed.

2.4 Sample collection and preservation

Collect a sufficient volume of sample for analysis (usually a minimum of 100 mL of sample). The World Health Organization guidelines recommend 200 mL per sample. Standard Methods for the Examination of Water and Wastewater recommends 100 mL per sample.

No dechlorination is necessary if the sample is added directly to the growth medium on site. If not, add a dechlorinating reagent to the samples to remove the chlorine residual. Sodium thiosulfate that has been sterilized in the collection vessel is used to remove chlorine residual. Transport the sample for analysis immediately after collection.

Analyze the samples as soon as possible after collection. If the analysis cannot be started immediately, keep the sample at or below 10 °C (50 °F), but do not freeze the sample. The maximum time between sample collection and incubation is 8 hours. Failure to collect and transport samples as specified will cause inaccurate results. Refer to the local regulatory agency for the most current holding times and temperatures.

Use sterilized plastic bags or disposable bottles

Use pre-sterilized Whirl-Pak® bags or bottles for sample collection. If the sample has been disinfected, use bags or bottles that contain a dechlorinating agent. Bags or bottles that contain dechlorinating reagent can be used for all samples because the dechlorinating reagent does not interfere with untreated samples. As an alternative, use autoclavable glass or plastic bottles.

Write the sample number, dilution, date and other necessary information on each sample container. Use aseptic technique to prevent internal contamination of the sample container.

Faucets, spigots, hydrants or pumps

1. Let the water flow at a moderate rate for 2 to 3 minutes (potable water).
2. Adjust the flow before the sample collection to prevent spills and splashes. Do not adjust the flow during the sample collection. Do not use valves, spigots and faucets that swivel or leak. Remove any aerators or screens.
3. Collect a minimum of 100 mL of the sample in a sterilized container. Do not fill the sample containers completely. Keep a minimum of 2.5 cm (1 inch) of air space to help mix the sample before analysis.

Note: Open the sample containers immediately before collection and close immediately after collection. Do not put the lid or cap down. Do not touch the lip or inner surfaces of the container. Do not rinse the containers before use.

4. Write the sample information on the container and start the analysis as soon as possible.

Rivers, lakes and reservoirs

1. Do not collect samples near the edge of the river, lake or reservoir.
2. If possible, remove the cap under water. As an alternative, remove the cap, grasp the sample container near the bottom and plunge the container, mouth down, into the water to exclude any surface scum.
3. Fill the container entirely under water. Put the mouth of the container into the current or, in non-flowing water, tilt the container slightly and let the container fill slowly. Do not rinse the container before use.
4. Write the sample information on the container and start the analysis as soon as possible.

2.5 Sample volumes

Use a sample volume that is applicable to the sample type. For samples with a low level of bacteria such as finished, potable water, use 100 mL of sample. Use less sample for non-potable water or water that contains more bacteria or turbidity. Refer to [Table 1](#) and [Table 2](#).

When the approximate bacteria density is unknown, analyze three different sample volumes. Use the result from the sample volume that shows approximately 20 to 200 colonies for each membrane filter. The best sample volume for total coliform tests will show approximately 20 to 80 coliform colonies with a maximum of 200 total bacteria colonies on the membrane filter. The best sample volume for fecal coliform tests will show approximately 20 to 60 coliform colonies with a maximum of 200 total bacteria colonies on the membrane filter.

When the sample volume is less than 20 mL (diluted or undiluted), add 10 mL of sterile buffered dilution water to the filter funnel before the vacuum is applied. The 10 mL of dilution water helps to apply the bacteria equally across the membrane filter. For very small sample volumes, make a series of dilutions.

Table 1 Total coliform sample volumes¹

| Water source | 100 mL | 50 mL | 10 mL | 1 mL | 0.1 mL | 0.01 mL | 0.001 mL | 0.0001 mL |
|---------------------|--------|-------|-------|------|--------|---------|----------|-----------|
| Drinking water | X | | | | | | | |
| Swimming pools | X | | | | | | | |
| Wells, springs | X | X | X | | | | | |
| Lakes, reservoirs | X | X | X | | | | | |
| Water supply intake | | | X | X | X | | | |

¹ *Standard Methods for the Examination of Water and Wastewater*, 19th edition, Table 9222:I, page 9–56

Bacteria analysis

Table 1 Total coliform sample volumes¹ (continued)

| Water source | 100 mL | 50 mL | 10 mL | 1 mL | 0.1 mL | 0.01 mL | 0.001 mL | 0.0001 mL |
|--------------------|--------|-------|-------|------|--------|---------|----------|-----------|
| Bathing beaches | | | X | X | X | | | |
| River water | | | | X | X | X | X | |
| Chlorinated sewage | | | | X | X | X | | |
| Raw sewage | | | | | X | X | X | X |

Table 2 Fecal coliform sample volumes²

| Water source | 100 mL | 50 mL | 10 mL | 1 mL | 0.1 mL | 0.01 mL | 0.001 mL |
|--|--------|-------|-------|------|--------|---------|----------|
| Lakes, reservoirs | X | X | | | | | |
| Wells, springs | X | X | | | | | |
| Water supply intake | | X | X | X | | | |
| Natural bathing waters | | X | X | X | | | |
| Sewage treatment plant, secondary effluent | | | X | X | X | | |
| Farm ponds, rivers | | | | X | X | X | |
| Storm water run-off | | | | X | X | X | |
| Raw municipal sewage | | | | | X | X | X |
| Feedlot run-off | | | | | X | X | X |

2.6 Sterile buffered dilution water

Use dilution water that is buffered to a neutral pH and sterilized for microbiological testing. Hach dilution water is recommended for dilution of most non-potable and wastewater samples. Each bottle contains 99 mL of sterile buffered dilution water.

When 11 mL of sample is added to a 99-mL bottle of dilution water, the sample is diluted by a factor of 10 (10-fold dilution). Before and after the sample is added, make sure to fully mix the bottles. The dilution factor of an undiluted sample = 1.

2.7 Serial sample dilutions

Make a series of dilutions to measure very small sample volumes. After dilution, pour 100 mL of the diluted sample into the membrane filter assembly.

1. Wash hands thoroughly with soap and water.
2. Invert the sample again and again for 30 seconds (25 times).
Note: Do not shake the sample too vigorously to prevent injury to the organisms.
3. Open a 99-mL bottle of sterile buffered dilution water.
4. Use a sterile pipet to add 11 mL of sample into the dilution water bottle.
5. Put the cap on the dilution water bottle and invert again and again for 30 seconds (25 times). This bottle contains a 10-fold or 10x dilution (the sample is diluted by a factor of 10). Refer to [Table 3](#).
6. Add 11 mL of the 10-fold dilution to a second dilution bottle and mix well (100x dilution).

¹ *Standard Methods for the Examination of Water and Wastewater*, 19th edition, Table 9222:I, page 9–56

² *Standard Methods for the Examination of Water and Wastewater*, 19th edition, Table 9222:III, page 9–61

7. Add 11 mL of the 100x dilution to a third dilution bottle and mix well (1000x dilution).
8. Continue to make dilutions until there are three different volumes of the applicable dilution for the type of sample that is used.

Table 3 Serial dilution example

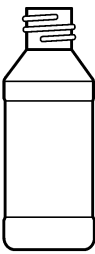
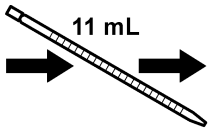
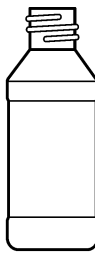
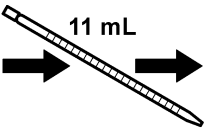
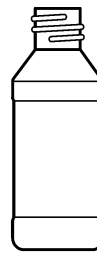
| | | | | |
|---|---|---|---|---|
|  |  |  |  |  |
| 99-mL of sterile buffered dilution water no sample added no dilution | Add 11 mL of sample to the bottle $11 \text{ mL sample} \div 110 \text{ mL total} = 0.1$ 10x dilution | | Add 11 mL of 10x dilution to a new bottle $11 \text{ mL} \times 0.1 \div 110 \text{ mL} = 0.01$ 100x dilution | |

2.8 Interpret and report the coliform results

Report the coliform density as the number of colonies in 100 mL of sample. For total coliforms, use a sample volume that gives 20–80 coliform colonies on the membrane filter. For fecal coliforms, use a sample volume that gives 20–60 fecal coliform colonies on the membrane filter.

If there are more than 200 colonies, dilute the sample and use the diluted sample in the test procedure. Use the sample volume before dilution in the coliform density determination.

1. Use the microscope to look at the colonies on the membrane filter. Count the number of isolated coliform colonies.
2. Determine the coliform density as follows:

| Membrane filter(s) | Coliform density determination |
|--|--|
| One membrane filter | Coliform colonies in 100 mL = Coliform colonies counted \div mL sample \times 100 <i>Example: 50 coliform colonies were counted. The sample volume was 20 mL. The coliform density is $50 \div 20 \text{ mL} \times 100 = 250$ coliforms in 100 mL of sample.</i> |
| Multiple filters, dilutions or duplicates for each sample | Average coliform colonies in 100 mL = Sum of coliform colonies in all samples \div sum of mL sample \times 100 <i>Example: Two 50-mL samples gave 5 colonies on one filter and 9 colonies on another filter. The coliform density is $(5 + 9) \div (50 + 50) \times 100 = 14$ coliforms in 100 mL of sample.</i> |

3. If colonies are not isolated or if there are more than 200 colonies of all types:
 - a. Report the results as “Confluent growth with or without coliforms” when the bacteria grows together across some or all of the membrane filter.
 - b. Do the test procedure again with half the sample volume. If the total number of colonies (coliforms plus non-coliforms) is more than 200 for each membrane or the colonies are not isolated, report the results as “Too numerous to count” (TNTC).
 - c. Do the test procedure again with a dilution that gives approximately 50 coliform colonies and not more than 200 colonies of all types.

2.9 Enrichment procedure for stressed bacteria

Many conditions such as disinfection can cause injury to bacteria. Bacteria after injury has occurred are known as stressed bacteria. Stressed bacteria are found in effluent waters after disinfection, saline waters and natural waters that contain poisonous compounds. Sampling conditions, sudden temperature changes, extremes in pH and low nutrient concentrations can also cause bacteria to become stressed.

Stressed bacteria will not grow or may grow very slowly during incubation. Use an enrichment procedure for samples with stressed bacteria. Refer to local or state agencies for accepted test procedures.

2.10 Controls for coliform bacteria tests

Positive and negative controls validate that the test gives a positive result when coliform bacteria are in the sample and a negative result when coliform bacteria are not in the sample. *Pseudomonas aeruginosa* is recommended as a negative control and *Escherichia coli* is recommended as a positive control.

2.11 Bacteria disposal

Make sure to kill the cultured bacteria before disposal. Refer to [Figure 1](#) and the information that follows.

- Microwave—Add 1–2 mL of hypochlorite (bleach) solution to each test container. If a container has a lid, do not close it too tightly. Put the container in the microwave at 70–80 °C (158–176 °F) for 50 seconds. Wait 10 to 15 minutes. Pour the liquid down the drain.
- Autoclave—Put the used test containers in a contaminated items bag or biohazard bag to prevent leaks. Do not seal the bag. Put the bag in the autoclave at 121 °C (250 °F) for 30 minutes at 1.0 bar (15 psi) of pressure. When the bag is cool, seal it and put it into a garbage bag. Make sure to tie the garbage bag tightly.

Figure 1 Bacteria disposal

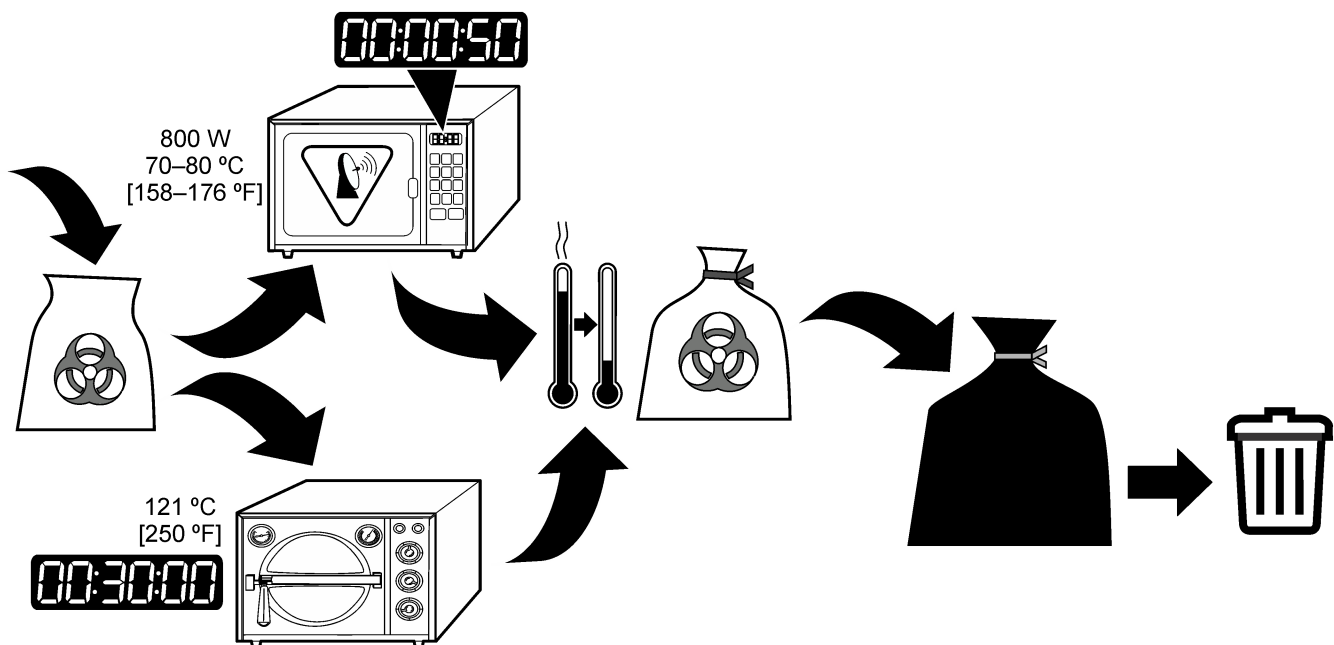

Microbiological Procedures

Coliforms, Total, Fecal and *E. coli*

m-Endo Broth Ampule¹

Method 8074

Membrane Filtration

Scope and application: For potable water, nonpotable water, recreation water and wastewater.

¹ Adapted from *Standard Methods for the Examination of Water and Wastewater*, 9222 B and 9221 B.



Test preparation

Before starting

Set the temperature of the incubator to 35 ± 0.5 °C (95 ± 0.9 °F). Let the incubator temperature become stable, then add the samples.

Read the sections on [Sample collection and preservation](#) on page 6 and [Sample volumes](#) on page 7. Read the section on [Serial sample dilutions](#) on page 8 if the sample is not used for drinking water.

Potable water must have no coliform bacteria. Do not dilute potable water samples.

Wash hands thoroughly with soap and water.

Use a germicidal cloth, bactericidal spray, weak bleach solution or weak iodine solution to clean the work area.

Make sure that all of the materials that come in contact with samples are sterile.

During filtration, remove the vacuum as soon as the funnel is empty so that the membrane filter does not become dry.

Items to collect

| Description | Quantity |
|--|----------|
| Broth ampule, m-Endo | 1 |
| Confirmation media | varies |
| Sterile buffered dilution water | varies |
| Funnel assembly with filter, pad, petri dish, manifold | 1 |
| Syringe | 1 |
| Forceps, sterilized | 1 |
| Incubator | 1 |
| Illuminated magnifier or 10 to 15X microscope | 1 |
| Pipet(s) for dilution or for sample volumes less than 100 mL, if necessary | 1 |

Refer to [Consumables and replacement items](#) on page 9 for order information.

Presumptive test for total coliforms

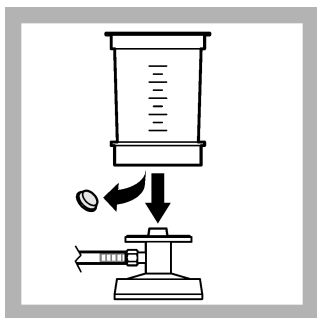

1. Remove the plug from the filter assembly. Push the filter assembly on the manifold.

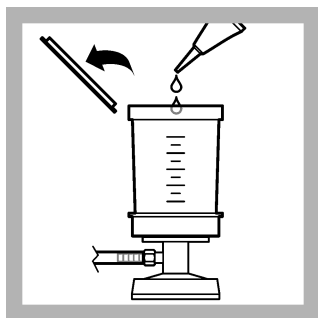

2. Open one m-Endo broth ampule. Lift the cover of the filter assembly and pour the contents equally on the absorbent pad in the petri dish. Remove the petri dish from the filter assembly.

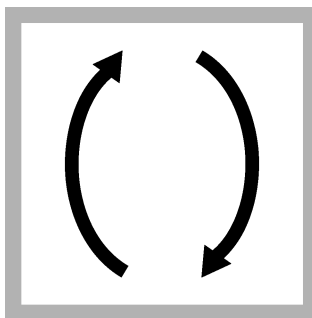

3. Invert the sample or the diluted sample for 30 seconds (25 times) to make sure that the sample is mixed well.

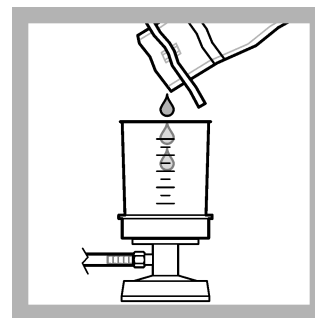

4. Pour 100 mL of the sample into the funnel. Pull the plunger on the syringe to pull the sample through the filter.

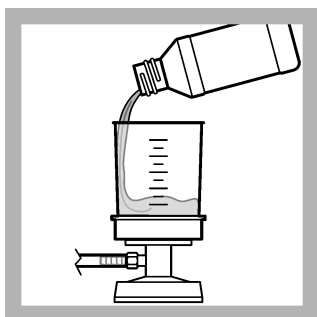

5. Rinse the funnel walls 3 times with 20 to 30 mL of sterile buffered dilution water. Use the syringe to pull the water through the filter after each rinse.

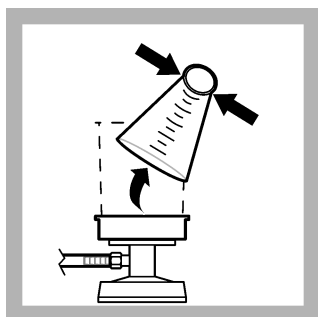

6. Squeeze the top of the funnel and remove the funnel from the filter assembly.

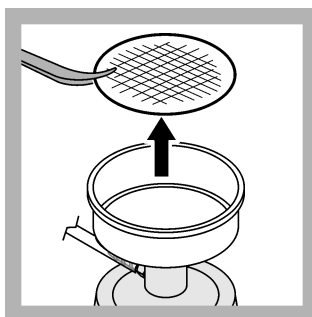

7. Use sterile forceps to lift the membrane filter from the base of the filter assembly.

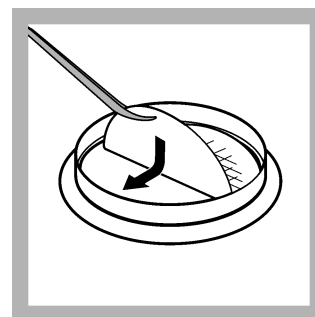

8. Put the membrane filter on the absorbent pad. Let the membrane filter bend and fall equally across the absorbent pad to make sure that air bubbles are not caught below the filter.

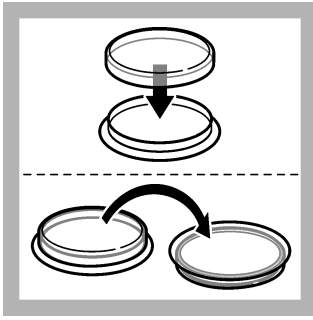

9. Put the lid on the petri dish and invert the petri dish.

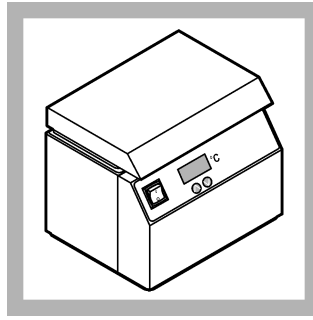

10. Incubate the inverted petri dish at 35 ± 0.5 °C (95 ± 0.9 °F) for 22–24 hours.

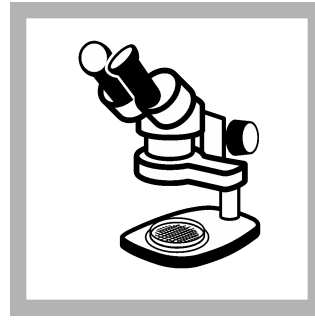

11. Remove the petri dish from the incubator. Use an illuminated magnifier or 10x to 15x microscope to count the number of colonies with a greenish-gold sheen. If the test is positive for coliform bacteria, start one or more confirmation procedures to confirm the presence of total coliforms, fecal coliforms or *E. coli*. Refer to [Interpret and report the coliform results](#) on page 9.

About confirmation of total coliforms

For potable water samples, do the confirmation procedure on typical colonies to make sure that they are coliforms. Confirm sheen colonies to a maximum of five. Move growth from each colony to inoculate parallel tubes of Lauryl Tryptose (LT) single-strength (SS) broth and Brilliant Green Bile (BGB) broth. Growth and gas production in the two tubes makes sure that the organisms are coliforms. Most Probable Number (MPN) coliform tubes are recommended for this procedure.

Use the swabbing technique for fecal coliforms or *E. coli* as follows:

- To determine only if total coliforms are in or not in the sample
- To inoculate EC or EC/MUG media

Inoculate in the sequence that follows:

1. EC or EC/MUG media
2. Lauryl Tryptose (LT) single-strength broth
3. Brilliant Green Bile (BGB) broth

Confirmation test of total coliforms (LT and BGB)

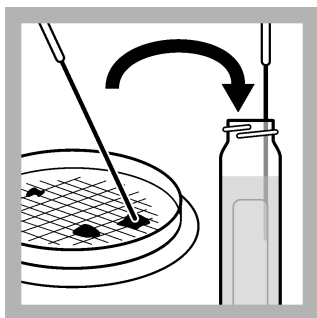

1. Touch a sterilized inoculating needle or a sterile disposable needle to the coliform (sheen) colony growth. Put the needle in a Lauryl Tryptose broth tube.

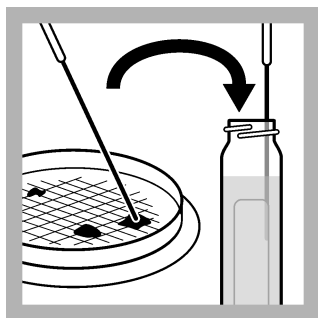

2. Touch the sterilized inoculating needle again to the same coliform (sheen) colony growth. Put the needle in a Brilliant Green Bile (BGB) broth tube.

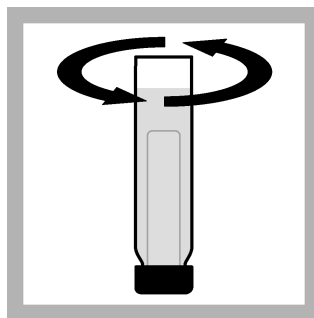

3. Invert the tubes to remove air from the inner vials. Gently swirl, if necessary.

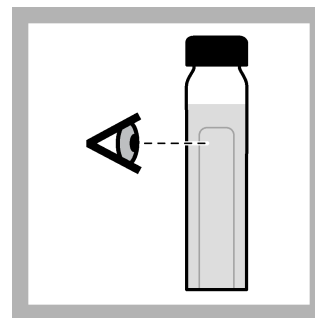

4. Examine the tubes to make sure that the inner vial (if Durham tubes are used) is full of liquid with no air bubbles.

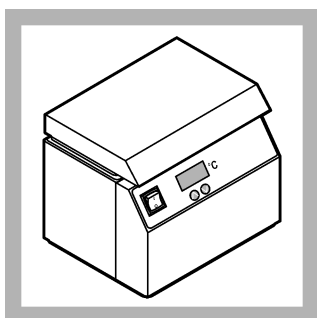

5. Incubate the inoculated confirmation media at 35 ± 0.5 °C (95 ± 0.9 °F) for 1 hour. Bubbles that form in the inner vials during the first hour are not from bacteria.

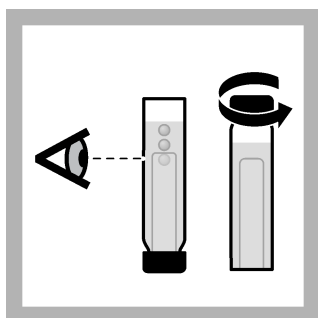

6. After 1 hour, invert the tubes to remove air from the inner vials. Make sure that there are no bubbles and keep the tubes in a vertical position. Loosen the caps only a little, then put the tubes in the incubator.

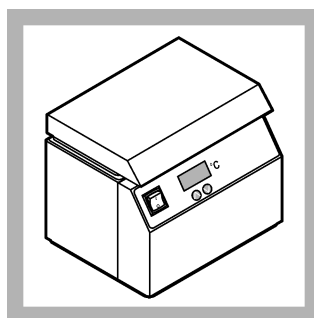

7. Incubate the inoculated confirmation media at 35 ± 0.5 °C (95 ± 0.9 °F) for 24 ± 2 hours. **Note:** *It is necessary to keep the tubes in a vertical position for the remainder of the test.*

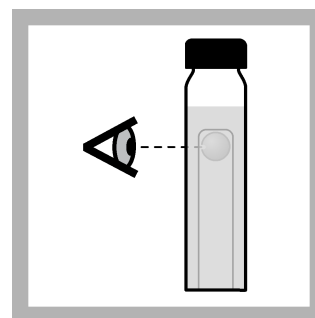

8. After 24 ± 2 hours, remove the samples from the incubator. Tap each tube gently and examine the inner vials for gas. If the broth is cloudy and the inner vials contain gas bubbles, coliform bacteria are likely in the sample. Any gas that shows is an indication of coliform bacteria. If no gas can be seen, put the tubes in the incubator for 24 ± 2 hours (48 ± 3 hours total) and examine the tubes again.

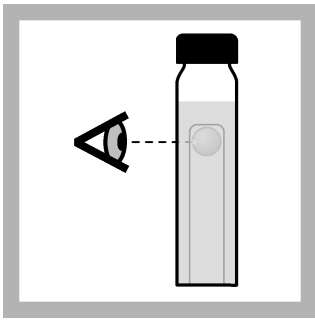

9. After 48 ± 3 hours, gently tap each tube and examine the inner vials for gas. If the inner vial contains gas bubbles, the test is positive for total coliform bacteria. If none of the tubes contain gas, then the test is negative for total coliform bacteria.

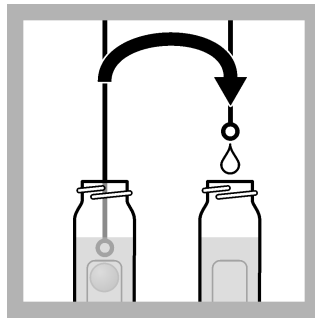

10. Confirm positive results. If growth and gas occur in the Lauryl Tryptose broth tube but not in the Brilliant Green Bile (BGB) broth tube, inoculate another Brilliant Green Bile (BGB) broth tube from the gas-positive Lauryl Tryptose broth tube.

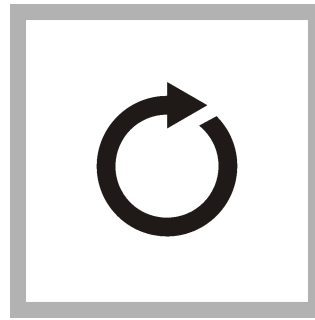

11. Do steps 3–9 again on the Brilliant Green Bile (BGB) broth tube. If growth and gas occur within 48 ± 3 hours, the colony is confirmed as coliform.

Confirmation test for fecal coliforms (EC Medium)

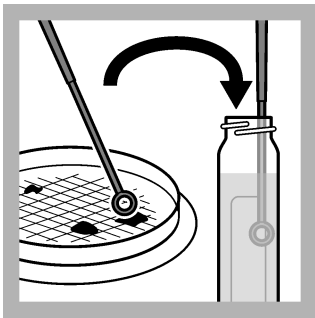

1. Use a sterile cotton swab or inoculating loop to touch all of the surface of the membrane filter that is positive for total coliforms.

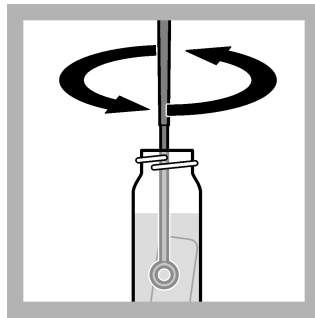

2. Swirl the cotton swab or inoculating loop in an EC Medium Broth tube to move the colonies collected from the filter to the tube.

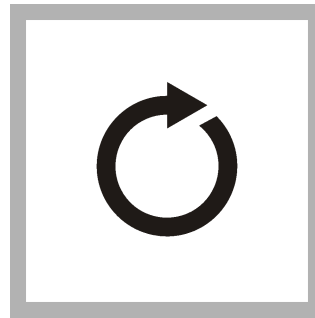

3. Do steps 1–2 again for each test to be verified. Use one broth tube for each test. Use a different cotton swab for each test.

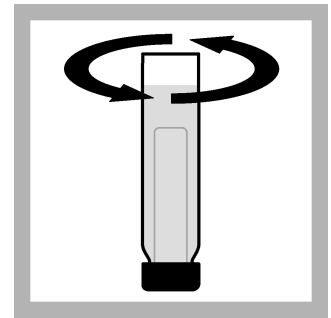

4. Invert the tubes to remove air from the inner vials. Gently swirl, if necessary.

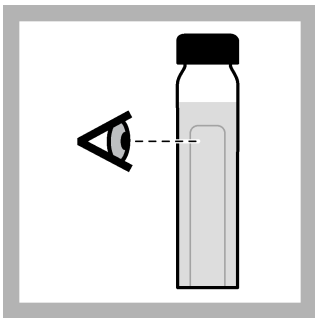

5. Examine the tubes to make sure that the inner vial (if Durham tubes are used) is full of liquid with no air bubbles.

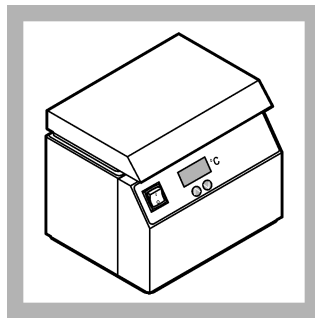

6. Incubate the inoculated confirmation media at 44.5 ± 0.2 °C (112.1 ± 0.4 °F) for 1 hour. Bubbles that form in the inner vials during the first hour are not from bacteria.

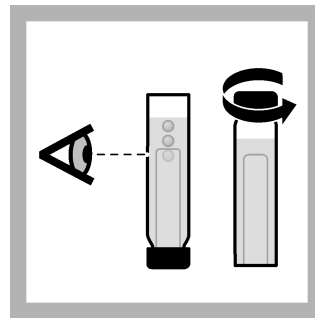

7. After 1 hour, invert the tubes to remove air from the inner vials. Make sure that there are no bubbles and keep the tubes in a vertical position. Loosen the caps only a little, then put the tubes in the incubator.

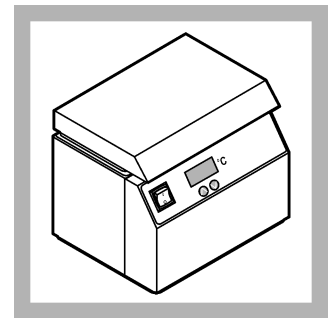

8. Incubate the inoculated confirmation media at 44.5 ± 0.2 °C (112.1 ± 0.4 °F) for 24 ± 2 hours.

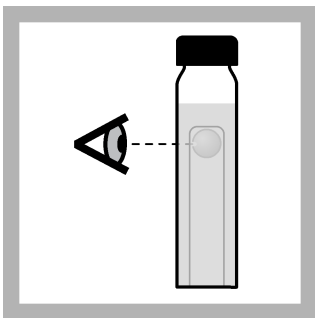

9. After 24 ± 2 hours, remove the samples from the incubator. Gently tap each tube and examine the inner vials for gas. If the inner vial contains gas bubbles, the test is positive for fecal coliform bacteria. If none of the tubes contain gas, then the test is negative for fecal coliform bacteria.

Confirmation of *E. coli* (EC or EC/MUG)

⚠ CAUTION



Ultraviolet (UV) light exposure hazard. Exposure to UV light can cause eye and skin damage. Protect eyes and skin from direct exposure to UV light.

When the nutritional media contains MUG, use a long-wave (e.g., 365 nm) UV lamp to confirm the presence of *E. coli*. The sample will fluoresce if *E. coli* is in the sample. No additional confirmation procedure is necessary.

Note: The sample container can fluoresce slightly. To help with fluorescence detection, use an *E. coli* Fluorescence Standard. Compare the fluorescence from the sample and the standard.



1. Use a sterile cotton swab or inoculating loop to touch all of the surface of the membrane filter that is positive for total coliforms.

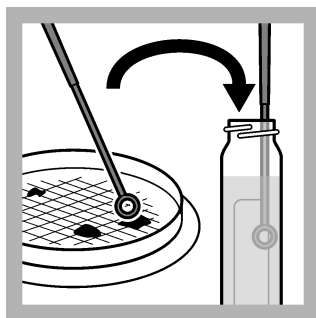

2. Swirl the cotton swab or inoculating loop in an EC/MUG Broth tube to move the colonies collected from the filter to the tube.

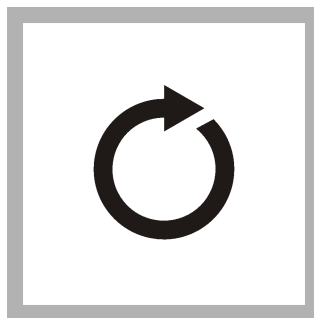

3. Do steps 1–2 again for each test to be verified. Use one broth tube for each test. Use the same cotton swab.

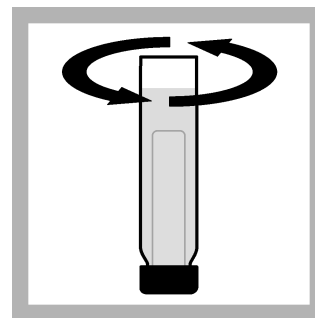

4. Invert the tubes to remove air from the inner vials. Gently swirl, if necessary.

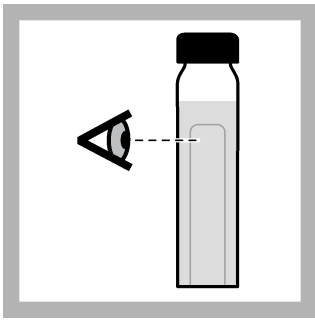

5. Examine the tubes to make sure that the inner vial (if Durham tubes are used) is full of liquid with no air bubbles.

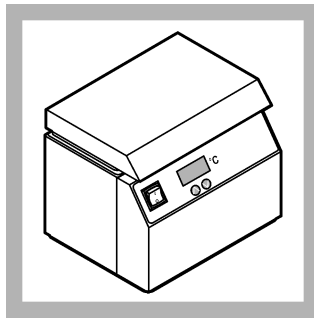

6. Incubate the inoculated confirmation media at $44.5 \pm 0.2 \text{ }^\circ\text{C}$ ($112.1 \pm 0.4 \text{ }^\circ\text{F}$) for 1 hour. Bubbles that form in the inner vials during the first hour are not from bacteria.

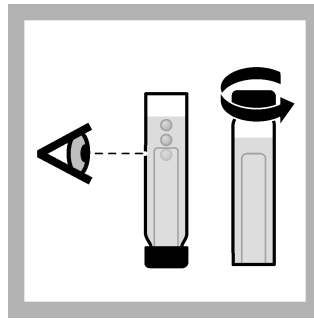

7. After 1 hour, invert the tubes to remove air from the inner vials. Make sure that there are no bubbles and keep the tubes in a vertical position. Loosen the caps only a little, then put the tubes in the incubator.

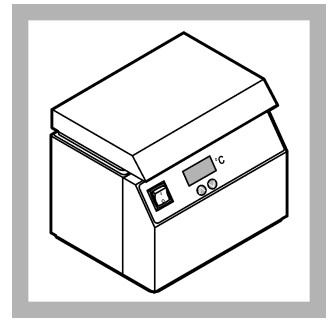

8. Incubate the inoculated confirmation media at $44.5 \pm 0.2 \text{ }^\circ\text{C}$ ($112.1 \pm 0.4 \text{ }^\circ\text{F}$) for 24 ± 2 hours.

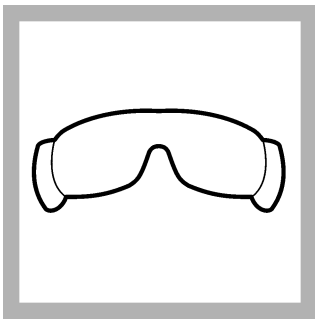

9. Put on UV safety goggles

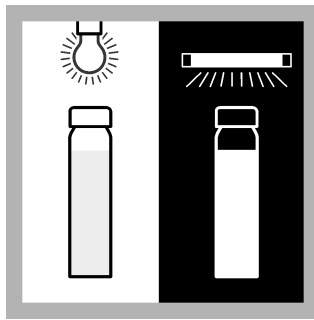

10. Apply UV light to the incubated sample that contains MUG broth with a long-wave UV lamp. Examine the tubes in a dark area. Look at the tube 90° from the UV light. Compare the fluorescence of the sample tubes to a tube that contains a known *E. coli* positive confirmation. If the sample fluoresces, *E. coli* bacteria are in the sample. If the sample does not fluoresce, the test is negative for *E. coli*.

Confirmation of *E. coli* (Nutrient Agar/MUG)

⚠ CAUTION



Ultraviolet (UV) light exposure hazard. Exposure to UV light can cause eye and skin damage. Protect eyes and skin from direct exposure to UV light.

When the nutritional media contains MUG, use a long-wave (e.g., 365 nm) UV lamp to confirm the presence of *E. coli*. The sample will fluoresce if *E. coli* is in the sample. No additional confirmation procedure is necessary.

Note: The sample container can fluoresce slightly. To help with fluorescence detection, use an *E. coli* Fluorescence Standard. Compare the fluorescence from the sample and the standard.

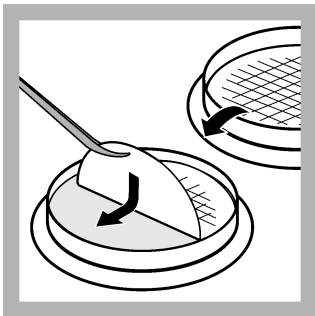

1. Use sterile forceps to put the membrane filter that is positive for total coliforms on the prepared NA/MUG agar plate. Let the membrane filter bend and fall equally across the agar to make sure that air bubbles are not caught below the filter.

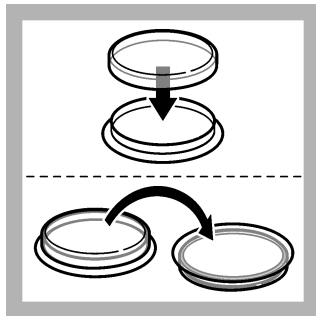

2. Put the lid on the petri dish and invert the petri dish.

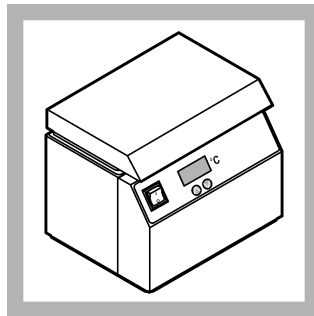

3. Incubate the inoculated confirmation media at 35 ± 0.5 °C (95 ± 0.9 °F) for 4 hours.

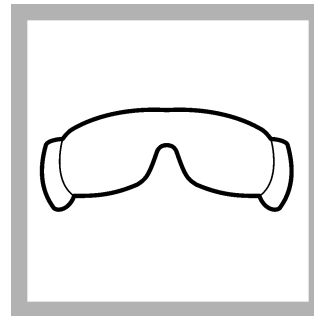

4. Put on UV safety goggles



5. Remove the lid from the petri dish. Apply UV light to the colonies in a dark area. If the colonies fluoresce, *E. coli* bacteria are in the sample. If the colonies do not fluoresce, the test is negative for *E. coli*.

Summary of method

Coliforms ferment lactose in the medium and form an acid-aldehyde complex. The complex mixes with Schiff's Reagent (also in the medium) to form an iridescent green coating above the colonies. When magnified 10x to 15x, coliforms show as dark red colonies with a greenish-gold sheen.

The membrane filtration procedure is used for samples that are low in turbidity and have low bacteria counts. The sample is poured through a membrane filter. The bacteria in the sample stays on the membrane filter. The membrane filter is moved to a petri dish that contains a nutritional broth or agar. During incubation, the bacteria grow and form colonies on the membrane filter. After incubation, the filter is examined with a microscope for bacteria colonies.

Consumables and replacement items

Required media

| Description | Quantity/Test | Unit | Item no. |
|---|---------------|--------|----------|
| m-Endo broth ampules, plastic, 2 mL (presumptive) | 1 | 50/pkg | 2373550 |
| Lauryl Tryptose broth tubes, single strength (total coliform confirmation) | 1 | 15/pkg | 2162315 |
| Brilliant Green Bile (BGB) broth tubes (total coliform confirmation) | varies | 15/pkg | 32215 |
| EC Medium broth tubes (fecal coliform confirmation) | varies | 15/pkg | 1410415 |
| EC Medium with MUG broth tubes with Durham tubes (fecal coliform and <i>E. coli</i> confirmation) | varies | 15/pkg | 2282415 |
| EC Medium with MUG broth tubes without Durham tubes (<i>E. coli</i> confirmation) | varies | 15/pkg | 2471515 |
| Nutrient agar with MUG prepared agar plates (<i>E. coli</i> confirmation) | 1 | 15/pkg | 2812115 |
| Dilution water, buffered, 99 mL, sterile ¹ | 1 | 25/pkg | 1430598 |

Required apparatus

| Description | Unit | Item no. |
|--|---------|----------|
| Microfunnel assembly, 100 mL, with 47-mm membrane filter (0.45- μ m pore size), absorbent pad and petri dish (sterile, disposable) | 50/pkg | 2831500 |
| Inoculating loop, nichrome wire | each | 2112100 |
| Magnifier, illuminated, 10X | each | 2585300 |
| Pipet, serological, 10–11 mL, sterile, disposable | 25/pkg | 209798 |
| Pipet filler, safety bulb | each | 1465100 |
| Sampling bags, Whirl-Pak [®] with dechlorinating agent, 180 mL, sterilized | 100/pkg | 2075333 |

Replacement items for MEL MF

| Description | Unit | Item no. |
|---|------|----------|
| Alcohol burner, 100 mL | each | 2087742 |
| Case assembly, MEL MF | each | 4781000 |
| Portable incubator with 12 VDC power socket | each | 2569900 |
| Laboratory marker | each | 2092000 |
| Forceps, stainless steel | each | 2141100 |
| Portable incubator rack, general purpose/petri dish | each | 2580502 |
| Thermometer, pocket, –10 to 110 °C | each | 187701 |
| Syringe, 140 mL | each | 2818300 |
| Counter, Hand-Tally | each | 1469600 |
| Manifold, field vacuum | each | 2831600 |

¹ Buffered dilution water is prepared with magnesium chloride and potassium dihydrogen phosphate.

Optional items

| Description | Quantity | Item no. |
|--|----------|----------|
| Biohazard bag | 200/pkg | 2463300 |
| <i>E. coli</i> fluorescence standard | each | 2361100 |
| Germicidal cloth | 50/pkg | 2463200 |
| Leica® EZ4 Stereo microscope with 10X eyepiece | each | 2942700 |
| Inoculating loops, sterile, disposable | 25/pkg | 2749125 |
| UV lamp, long-wave, portable, 4 watt | each | 2415200 |
| Wicks, replacement, for alcohol burner (2087742) | 10/pkg | 2097810 |



FOR TECHNICAL ASSISTANCE, PRICE INFORMATION AND ORDERING:
In the U.S.A. – Call toll-free 800-227-4224
Outside the U.S.A. – Contact the HACH office or distributor serving you.
On the Worldwide Web – www.hach.com; E-mail – techhelp@hach.com

HACH COMPANY
WORLD HEADQUARTERS
Telephone: (970) 669-3050
FAX: (970) 669-2932

Coliforms, Fecal

m-FC and m-FC/RA Broth PourRite Ampules¹

Method 8074

Membrane Filtration

Scope and application: For potable water, nonpotable water, recreation water and wastewater.

¹ USEPA approved 9222 D.



Test preparation

Before starting

Set the temperature of the incubator to 44.5 ± 0.2 °C (112.1 ± 0.4 °F). Let the incubator temperature become stable, then add the samples.

Read the sections on [Sample collection and preservation](#) on page 6 and [Sample volumes](#) on page 7. Read the section on [Serial sample dilutions](#) on page 8 if the sample is not used for drinking water.

To remove environmental Klebsiella from the fecal coliform population, increase the incubator temperature to 45.0 ± 0.2 °C (113 ± 0.4 °F).

Use m-FC Broth with Rosolic Acid to increase specificity when high levels of non-coliform bacteria can be in the sample, unless all of the organisms in the sample are stressed or injured.

Wash hands thoroughly with soap and water.

Use a germicidal cloth, bactericidal spray, weak bleach solution or weak iodine solution to clean the work area.

Make sure that all of the materials that come in contact with samples are sterile.

During filtration, remove the vacuum as soon as the funnel is empty so that the membrane filter does not become dry.

Items to collect

| Description | Quantity |
|--|----------|
| Broth ampule, m-FC | 1 |
| Confirmation media | varies |
| Sterile buffered dilution water | varies |
| Funnel assembly with filter, pad, petri dish, manifold | 1 |
| Syringe | 1 |
| Forceps, sterilized | 1 |
| Incubator | 1 |
| Illuminated magnifier or 10 to 15X microscope | 1 |
| Pipet(s) for dilution or for sample volumes less than 100 mL, if necessary | 1 |

Refer to [Consumables and replacement items](#) on page 5 for order information.

Presumptive test for fecal coliforms

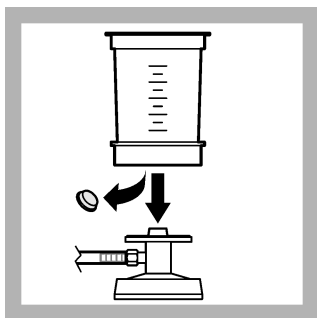

1. Remove the plug from the filter assembly. Push the filter assembly on the manifold.

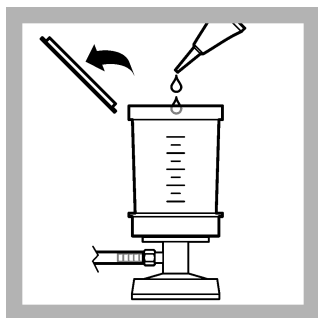

2. Open one m-FC broth ampule. Lift the cover of the filter assembly and pour the contents equally on the absorbent pad in the petri dish. Remove the petri dish from the filter assembly.

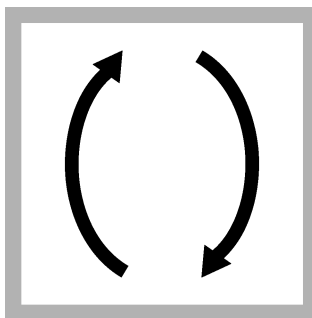

3. Dilute the sample as necessary. Refer to [Serial sample dilutions](#) on page 8. Invert the diluted sample for 30 seconds (25 times) to make sure that the sample is mixed well.



4. Pour 100 mL of the diluted sample into the funnel. Pull the plunger on the syringe to pull the sample through the filter.

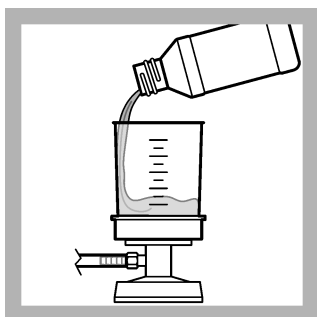

5. Rinse the funnel walls 3 times with 20 to 30 mL of sterile buffered dilution water. Use the syringe to pull the water through the filter after each rinse.

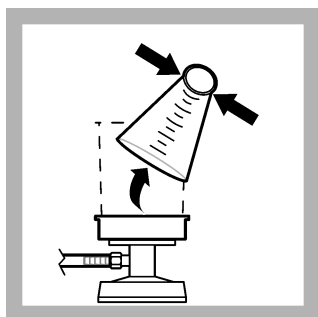

6. Squeeze the top of the funnel and remove the funnel from the filter assembly.

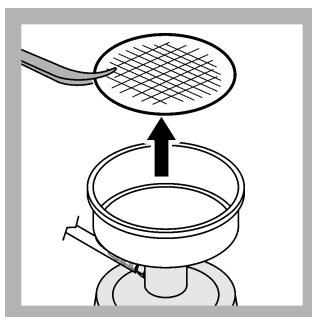

7. Use sterile forceps to lift the membrane filter from the base of the filter assembly.

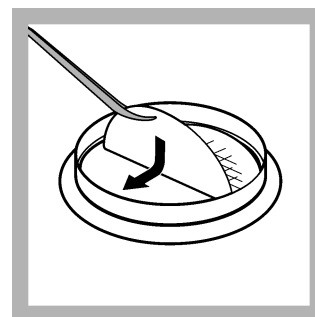

8. Put the membrane filter on the absorbent pad. Let the membrane filter bend and fall equally across the absorbent pad to make sure that air bubbles are not caught below the filter.

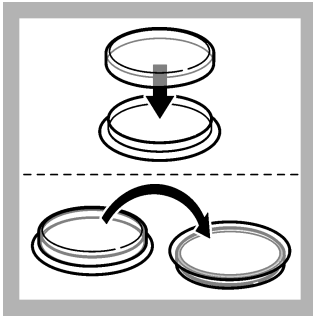

9. Put the lid on the petri dish and invert the petri dish.

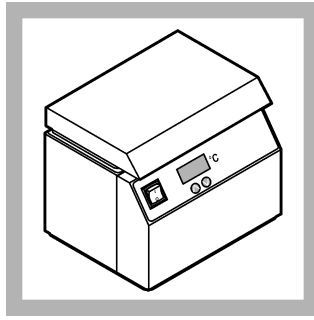

10. Incubate the inverted petri dish at 44.5 ± 0.2 °C (112.1 ± 0.4 °F) for 24 ± 2 hours.

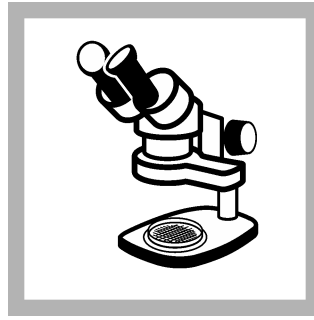

11. Remove the petri dish from the incubator. Use an illuminated magnifier or 10x to 15x microscope to count the number of blue colonies. Confirm positive results. If stressed organisms were tested, confirm a minimum of 10% of the blue colonies. Refer to [Interpret and report the coliform results](#) on page 9.

Confirmation of fecal coliforms (LT and EC)

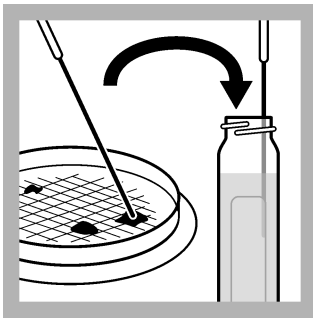

1. Touch a sterilized inoculating needle or a sterile disposable needle to a typical blue colony. Put the needle in a Lauryl Tryptose broth tube.

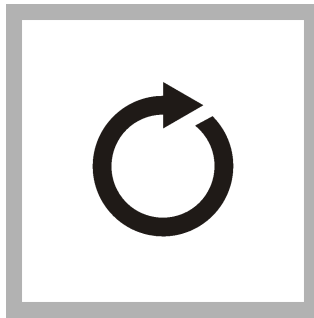

2. Do step 1 again for each test being verified. Use one Lauryl Tryptose broth tube for each test.

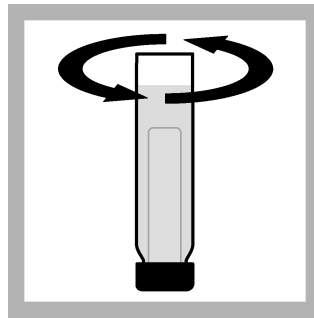

3. Invert the tubes to remove air from the inner vials. Gently swirl, if necessary.

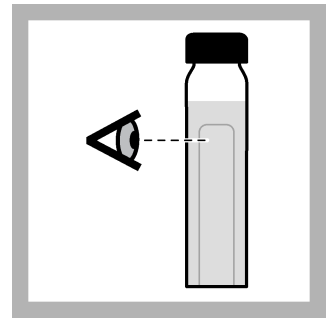

4. Examine the tubes to make sure that the inner vial (if Durham tubes are used) is full of liquid with no air bubbles.

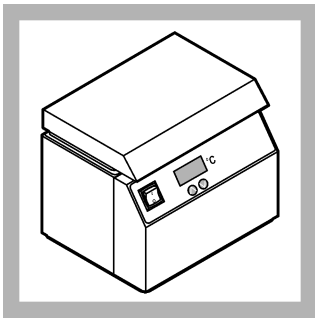

5. Incubate the inoculated confirmation media at 35 ± 0.5 °C (95 ± 0.9 °F) for 1 hour.

Bubbles that form in the inner vials during the first hour are not from bacteria.

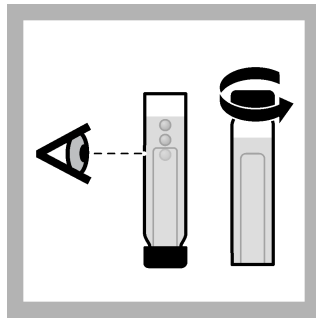

6. After 1 hour, invert the tubes to remove air from the inner vials. Make sure that there are no bubbles and keep the tubes in a vertical position. Loosen the caps only a little, then put the tubes in the incubator.

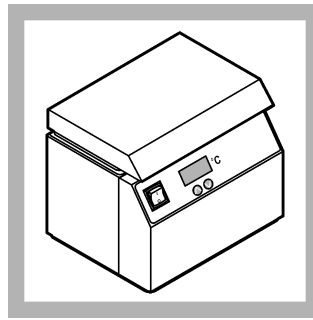

7. Incubate the inoculated confirmation media at 35 ± 0.5 °C (95 ± 0.9 °F) for 24 ± 2 hours.

Note: *It is necessary to keep the tubes in a vertical position for the remainder of the test.*

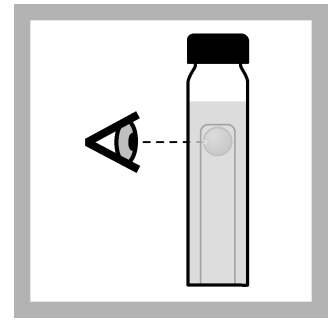

8. After 24 ± 2 hours, remove the samples from the incubator. Tap each tube gently and examine the inner vials for gas.

If the broth is cloudy and the inner vials contain gas bubbles, coliform bacteria are likely in the sample. Any gas that shows is an indication of coliform bacteria.

If no gas can be seen, put the tubes in the incubator for 24 ± 2 hours (48 ± 3 hours total) and examine the tubes again.

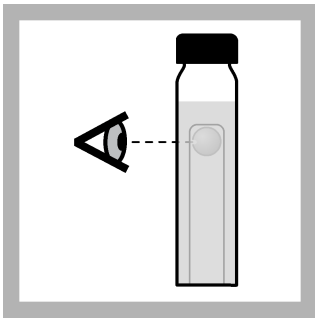

9. After 48 ± 3 hours, gently tap each tube and examine the inner vials for gas. If the inner vial contains gas bubbles, the test is positive for fecal coliform bacteria. If none of the tubes contain gas, then the test is negative for fecal coliform bacteria.

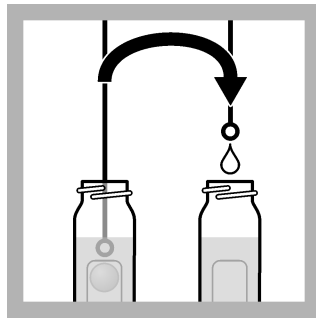

10. If the inner vial contains gas bubbles, use a sterile loop to inoculate an EC Medium Broth tube from the gas-positive Lauryl Tryptose broth tube.

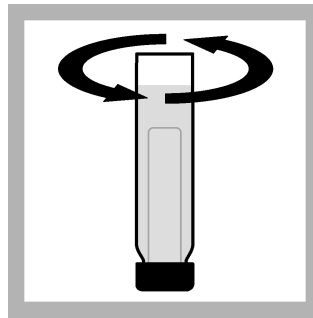

11. Invert the tubes to remove air from the inner vials. Gently swirl, if necessary.

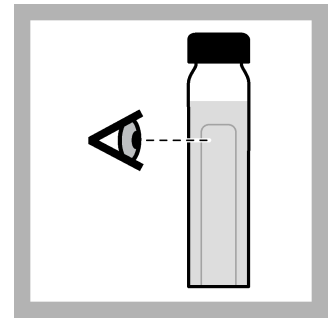

12. Examine the tubes to make sure that the inner vial (if Durham tubes are used) is full of liquid with no air bubbles.

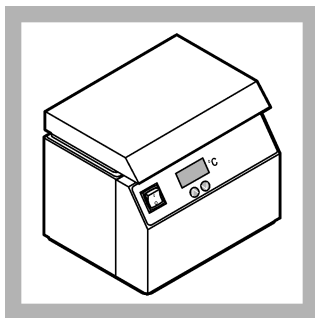

13. Incubate the inoculated confirmation media at 44.5 ± 0.2 °C (112.1 ± 0.4 °F) for 1 hour. Bubbles that form in the inner vials during the first hour are not from bacteria.

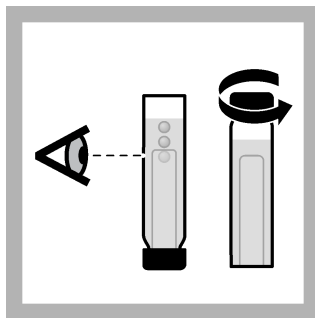

14. After 1 hour, invert the tubes to remove air from the inner vials. Make sure that there are no bubbles and keep the tubes in a vertical position. Loosen the caps only a little, then put the tubes in the incubator.

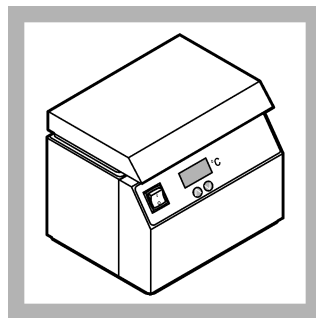

15. Incubate the inoculated confirmation media at 44.5 ± 0.2 °C (112.1 ± 0.4 °F) for 24 ± 2 hours.

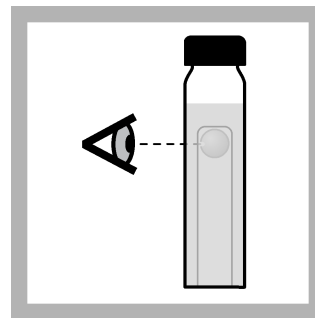

16. After 24 ± 2 hours, remove the tubes from the incubator. Tap each tube gently and examine the inner vials for gas. If the inner vial contains gas bubbles, the test is positive for fecal coliform bacteria. If no gas is seen, the test is negative for fecal coliform bacteria.

Summary of method

A fecal coliform test is usually done on wastewater, river, bathing, and other non-potable waters. A special medium and an elevated incubation temperature prevent growth of non-fecal coliforms. Fecal coliforms that grow on the membrane form an acid that reacts with an aniline dye in the medium. A blue color forms.

Use m-FC Broth with Rosolic Acid to increase specificity when high levels of non-coliform bacteria can be in the sample, unless all of the organisms in the sample are stressed or injured.

The membrane filtration procedure is used for samples that are low in turbidity and have low bacteria counts. The sample is poured through a membrane filter. The bacteria in the sample stays on the membrane filter. The membrane filter is moved to a petri dish that contains a nutritional broth or agar. During incubation, the bacteria grow and form colonies on the membrane filter. After incubation, the filter is examined with a microscope for bacteria colonies.

Consumables and replacement items

Required media

| Description | Quantity/test | Unit | Item no. |
|--|---------------|--------|----------|
| m-FC broth ampules, plastic | 1 | 50/pkg | 2373250 |
| m-FC with Rosolic Acid broth ampules, plastic | 1 | 50/pkg | 2428550 |
| Lauryl Tryptose broth tubes, single strength (total coliform confirmation) | 1 | 15/pkg | 2162315 |
| EC Medium broth tubes (fecal coliform confirmation) | varies | 15/pkg | 1410415 |
| Dilution water, buffered, 99 mL, sterile ¹ | 1 | 25/pkg | 1430598 |

¹ Buffered dilution water is prepared with magnesium chloride and potassium dihydrogen phosphate.

Required apparatus

| Description | Unit | Item no. |
|--|---------|----------|
| Microfunnel assembly, 100 mL, with 47-mm membrane filter (0.45- μ m pore size), absorbent pad and petri dish (sterile, disposable) | 50/pkg | 2831500 |
| Magnifier, illuminated, 10X | each | 2585300 |
| Pipet, serological, 10–11 mL, sterile, disposable | 25/pkg | 209798 |
| Pipet filler, safety bulb | each | 1465100 |
| Sampling bags, Whirl-Pak [®] with dechlorinating agent, 180 mL, sterilized | 100/pkg | 2075333 |

Replacement items for MEL MF

| Description | Unit | Item no. |
|---|------|----------|
| Alcohol burner, 100 mL | each | 2087742 |
| Case assembly, MEL MF | each | 4781000 |
| Portable incubator with 12 VDC power socket | each | 2569900 |
| Laboratory marker | each | 2092000 |
| Forceps, stainless steel | each | 2141100 |
| Portable incubator rack, general purpose/petri dish | each | 2580502 |
| Thermometer, pocket, –10 to 110 °C | each | 187701 |
| Syringe, 140 mL | each | 2818300 |
| Counter, Hand-Tally | each | 1469600 |
| Manifold, field vacuum | each | 2831600 |

Optional items

| Description | Quantity | Item no. |
|--|----------|----------|
| Biohazard bag | 200/pkg | 2463300 |
| Germicidal cloth | 50/pkg | 2463200 |
| Leica [®] EZ4 Stereo microscope with 10X eyepiece | each | 2942700 |
| Inoculating loops, sterile, disposable | 25/pkg | 2749125 |
| Inoculating loop, nichrome wire | each | 2112100 |
| Wicks, replacement, for alcohol burner (2087742) | 10/pkg | 2097810 |



FOR TECHNICAL ASSISTANCE, PRICE INFORMATION AND ORDERING:
In the U.S.A. – Call toll-free 800-227-4224
Outside the U.S.A. – Contact the HACH office or distributor serving you.
On the Worldwide Web – www.hach.com; E-mail – techhelp@hach.com

HACH COMPANY
WORLD HEADQUARTERS
Telephone: (970) 669-3050
FAX: (970) 669-2932

Coliforms, *E. coli*

modified m-TEC prepared Agar¹

Method 8367

Membrane Filtration

Scope and application: For potable water, nonpotable water, recreation water and wastewater.

¹ USEPA accepted.



Test preparation

Before starting

Set the temperature of the incubator to 35 ± 0.5 °C (95 ± 0.9 °F). Let the incubator temperature become stable, then add the samples.

Read the sections on [Sample collection and preservation](#) on page 6 and [Sample volumes](#) on page 7. Read the section on [Serial sample dilutions](#) on page 8 if the sample is not used for drinking water.

Wash hands thoroughly with soap and water.

Use a germicidal cloth, bactericidal spray, weak bleach solution or weak iodine solution to clean the work area.

Make sure that all of the materials that come in contact with samples are sterile.

During filtration, remove the vacuum as soon as the funnel is empty so that the membrane filter does not become dry.

Items to collect

| Description | Quantity |
|--|----------|
| m-TEC, prepared agar plates | 1 |
| Sterile buffered dilution water | 1 |
| Funnel assembly with filter, pad, petri dish, manifold | 1 |
| Syringe | 1 |
| Forceps, sterilized | 1 |
| Incubator | 1 |
| Illuminated magnifier or 10 to 15X microscope | 1 |
| Pipet(s) for dilution or for sample volumes less than 100 mL, if necessary | 1 |

Refer to [Consumables and replacement items](#) on page 3 for order information.

E. coli procedure

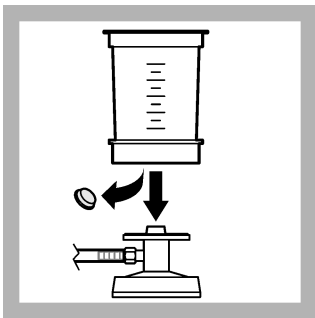

1. Remove the plug from the filter assembly. Push the filter assembly on the manifold. Remove the petri dish from the top of the filter assembly.

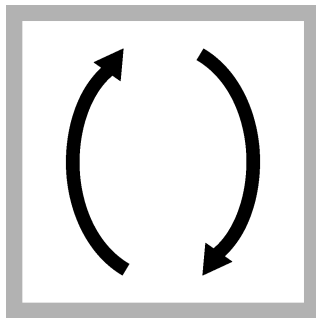

2. Dilute the sample as necessary. Refer to [Serial sample dilutions](#) on page 8. Invert the diluted sample for 30 seconds (25 times) to make sure that the sample is mixed well.



3. Pour 100 mL of the diluted sample into the funnel. Pull the plunger on the syringe to pull the sample through the filter.



4. Rinse the funnel walls 3 times with 20 to 30 mL of sterile buffered dilution water. Use the syringe to pull the water through the filter after each rinse.

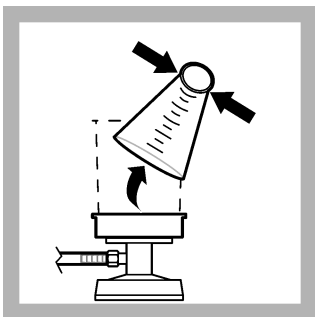

5. Squeeze the top of the funnel and remove the funnel from the filter assembly.

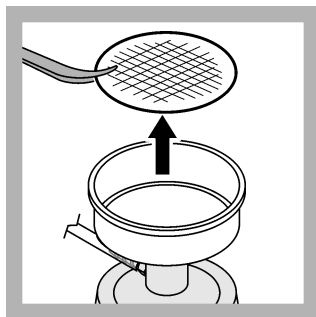

6. Use sterile forceps to lift the membrane filter from the base of the filter assembly.

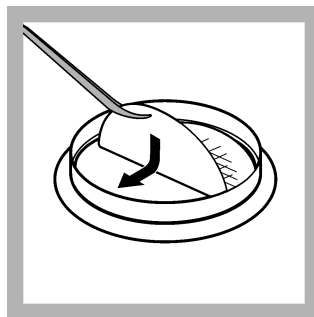

7. Put the membrane filter on the modified m-TEC prepared agar plate. Let the membrane filter bend and fall equally across the agar to make sure that air bubbles are not caught below the filter.

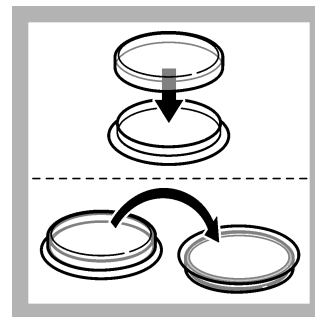

8. Put the lid on the petri dish and invert the petri dish.

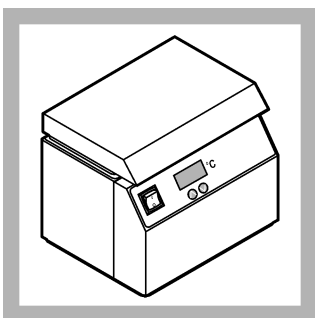

9. Incubate the inverted petri dish at 35 ± 0.5 °C (95 ± 0.9 °F) for 2 hours, then at 44.5 °C (112.1 °F) for 22 hours.

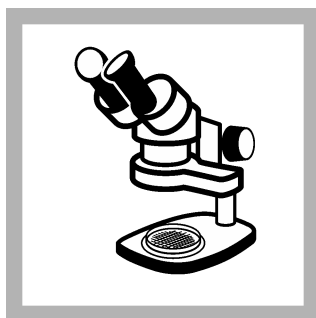

10. Remove the petri dish from the incubator. Use an illuminated magnifier or 10x to 15x microscope to count the number of red or magenta colonies.

Summary of method

This method uses modified m-TEC Agar to find *E. coli* bacteria in water samples. The modified m-TEC Agar has an enzymatic substrate, which is bonded to form colonies. Red

or magenta colonies show that *E. coli* is in the sample. A confirmation procedure is not necessary with this method.

The membrane filtration procedure is used for samples that are low in turbidity and have low bacteria counts. The sample is poured through a membrane filter. The bacteria in the sample stays on the membrane filter. The membrane filter is moved to a petri dish that contains a nutritional broth or agar. During incubation, the bacteria grow and form colonies on the membrane filter. After incubation, the filter is examined with a microscope for bacteria colonies.

Consumables and replacement items

Required reagents

| Description | Quantity/test | Unit | Item no. |
|---|---------------|--------|----------|
| m-TEC, modified, prepared agar plates | 1 | 15/pkg | 2811815 |
| Dilution water, buffered, 99 mL, sterile ¹ | 1 | 25/pkg | 1430598 |

Required apparatus

| Description | Unit | Item no. |
|--|---------|----------|
| Microfunnel assembly, 100 mL, with 47-mm membrane filter (0.45- μ m pore size), absorbent pad and petri dish (sterile, disposable) | 50/pkg | 2831500 |
| Magnifier, illuminated , 10X | each | 2585300 |
| Pipet, serological, 10–11 mL, sterile, disposable | 25/pkg | 209798 |
| Pipet filler, safety bulb | each | 1465100 |
| Sampling bags, Whirl-Pak [®] with dechlorinating agent, 180 mL, sterilized | 100/pkg | 2075333 |

Replacement items for MEL MF

| Description | Unit | Item no. |
|---|------|----------|
| Alcohol burner, 100 mL | each | 2087742 |
| Case assembly, MEL MF | each | 4781000 |
| Portable incubator with 12 VDC power socket | each | 2569900 |
| Laboratory marker | each | 2092000 |
| Forceps, stainless steel | each | 2141100 |
| Portable incubator rack, general purpose/petri dish | each | 2580502 |
| Thermometer, pocket, –10 to 110 °C | each | 187701 |
| Syringe, 140 mL | each | 2818300 |
| Counter, Hand-Tally | each | 1469600 |
| Manifold, field vacuum | each | 2831600 |

Optional items

| Description | Quantity | Item no. |
|------------------|----------|----------|
| Biohazard bag | 200/pkg | 2463300 |
| Germicidal cloth | 50/pkg | 2463200 |

¹ Buffered dilution water is prepared with magnesium chloride and potassium dihydrogen phosphate.

Optional items (continued)

| Description | Quantity | Item no. |
|--|----------|----------|
| Leica® EZ4 Stereo microscope with 10X eyepiece | each | 2942700 |
| Wicks, replacement, for alcohol burner (2087742) | 10/pkg | 2097810 |



FOR TECHNICAL ASSISTANCE, PRICE INFORMATION AND ORDERING:
In the U.S.A. – Call toll-free 800-227-4224
Outside the U.S.A. – Contact the HACH office or distributor serving you.
On the Worldwide Web – www.hach.com; E-mail – techhelp@hach.com

HACH COMPANY
WORLD HEADQUARTERS
Telephone: (970) 669-3050
FAX: (970) 669-2932

HACH COMPANY World Headquarters

P.O. Box 389, Loveland, CO 80539-0389 U.S.A.
Tel. (970) 669-3050
(800) 227-4224 (U.S.A. only)
Fax (970) 669-2932
orders@hach.com
www.hach.com

HACH LANGE GMBH

Willstätterstraße 11
D-40549 Düsseldorf, Germany
Tel. +49 (0) 2 11 52 88-320
Fax +49 (0) 2 11 52 88-210
info-de@hach.com
www.de.hach.com

HACH LANGE Sàrl

6, route de Compois
1222 Vérenaz
SWITZERLAND
Tel. +41 22 594 6400
Fax +41 22 594 6499

