

USER Manual MARWIS / StaRWIS

MARWIS

Mobile
Advanced
Road
Weather
Information
Sensor



a passion for precision · passion pour la précision · pasión por la precisión · passione per la precisione · a p

StaRWIS

Stationary
Road
Weather
Information
Sensor

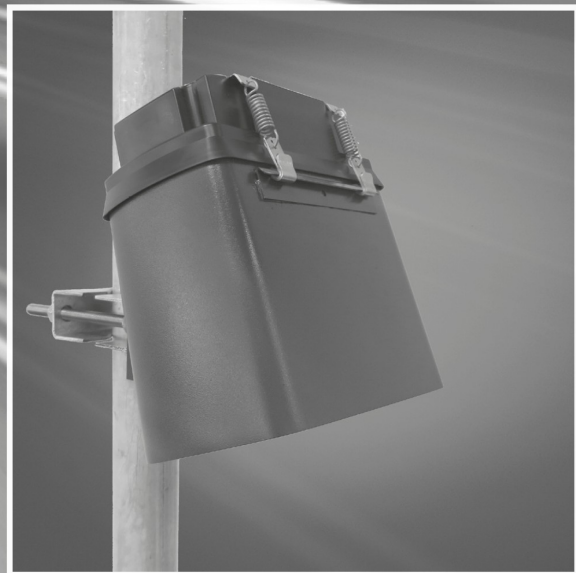

www.lufft.com

 **Lufft**

Contents

1	Read before use.....	6
1.1	Used symbols.....	6
1.2	Safety instructions.....	6
1.3	Designated use.....	6
1.4	Incorrect use.....	6
1.5	Guarantee.....	6
1.6	Brand names.....	7
2	Scope of delivery	7
3	Part numbers.....	7
3.1	MARWIS-UMB.....	7
3.2	Accessories.....	8
3.3	Spare parts.....	8
3.4	Additional documents and software.....	8
4	Equipment description.....	9
4.1	Road surface temperature.....	9
4.2	Ambient temperature.....	9
4.3	Relative humidity ²	9
4.4	Dew point temperature.....	9
4.5	Relative humidity at road temperature.....	9
4.6	Water film height.....	9
4.7	Road condition.....	10
4.8	Ice percentage.....	10
4.9	Snow Height.....	10
4.10	Friction.....	10
4.11	Sensor technology MARWIS-UMB.....	11
4.12	Status-LED.....	12
5	Generation of measurements	12
5.1	Current measurement (act).....	12
5.2	Normal operation.....	12
6	Measurement output.....	13
6.1	Measurements.....	13
6.1.1	Road Surface Temperature.....	13
6.1.2	AmbientTemperature.....	13
6.1.3	Relative Humidity.....	13
6.1.4	Dew point temperature.....	13
6.1.5	Relative humidity at road temperature.....	14
6.1.6	Water film height.....	14
6.1.7	Water film height on smooth surface.....	14
6.1.8	Road condition.....	14
6.1.9	Ice percentage.....	15
6.1.10	Snow Height.....	15
6.1.11	Friction.....	15
6.2	Additional sensor information.....	15
6.2.1	Device status.....	16
6.2.2	Measurement status.....	16
7	Mounting.....	18
7.1	Hints for mounting MARWIS-UMB.....	18
7.2	Mounting height.....	18
7.2.1	8900.U03, Mounting with short protective housing, angle 20°.....	18
7.2.2	8900.U04, Mounting with short protective housing, angle 20°.....	18
7.2.3	8900.U05, Mounting with short protective housing, angle 20°.....	18
7.2.4	8900.U03, Mounting with long protective housing, angle 10°.....	19
7.2.5	8900.U04, Mounting with long protective housing, angle 10°.....	19
7.3	Protective housing.....	20
7.3.1	Connecting the MARWIS-UMB to the protective housing.....	20
7.4	Example: Mounting with magnetic bar carrier for horizontal installation and short protective housing.....	25
7.5	Example: Mounting with magnetic bar carrier for vertical installation and long protective housing.....	25

8	Connections.....	26
8.1	Connection plug.....	26
8.2	Pin assignment.....	26
8.3	Supply voltage.....	27
8.4	RS485-interface.....	27
8.5	Bluetooth connection.....	27
9	Commissioning.....	28
9.1	Adaption of the sensor.....	28
9.1.1	Possible reasons why an adaption may fail.....	28
9.2	Selecting the settings for the road condition model.....	28
9.2.1	Illustration of how the road condition is determined.....	29
9.3	Important hints prior to commissioning.....	30
10	Carrying out the sensor adaption.....	31
10.1	Adaption with the MARWIS-App.....	31
11	Configuration and test.....	31
11.1	Factory Settings.....	31
12	Firmware Update.....	32
12.1	Update with the MARWIS-App or ConfigTool.Net.....	32
13	Maintenance.....	32
13.1	Cleaning the sensor front glass pane.....	32
13.2	Checking the bolted connections.....	32
14	Technical Data.....	33
14.1	Device.....	33
14.2	Measuring Range / Accuracy.....	34
14.2.1	Road Surface Temperature.....	34
14.2.2	Road Condition.....	34
14.2.3	Dew point temperature.....	34
14.2.4	Water film.....	34
14.2.5	Relative humidity at road temperature.....	34
14.2.6	Relative humidity.....	35
14.2.7	Ambient temperature.....	35
14.2.8	Friction.....	35
14.2.9	Ice percentage.....	35
14.2.10	Snow Height.....	35
14.3	Drawings.....	36
14.3.1	MARWIS-UMB with short protective housing.....	36
14.3.2	MARWS-UMB with long protective housing.....	37
15	Declaration of Conformity.....	38
15.1	EC Certificate of Conformity.....	38
15.2	FCC Compliance statement (US).....	38
15.3	IC Compliance statement (CA).....	39
16	Disturbances.....	40
16.1	Possible errors occurring on the MARWIS-UMB.....	40
16.2	Interfering factors which can influence the measurement result.....	40
17	Disposal.....	41
17.1	Within the EU.....	41
17.2	Outside the EU.....	41
18	Repair / Corrective Maintenance.....	41
18.1	Technical Support.....	41
19	Appendix.....	42
19.1	Channel List Summary.....	42
19.2	Communication in binary protocol.....	43
19.2.1	Framing.....	44
19.2.2	Addressing with Class and Device ID.....	44
19.2.3	Example for creating addresses.....	45
19.2.4	Example online data query.....	45
19.2.5	Example online data query multiple channels.....	46
19.2.6	Example online data query multiple channels V1.1.....	46

19.3 CAN Protocol (Version 1.0).....	48
19.3.1 General remarks.....	48
19.3.2 Pin assignment.....	48
19.3.3 CAN-Parameter.....	48
19.3.4 Data format and byte order in the communication protocol.....	48
19.3.5 Data transmission.....	48
19.3.5.1 CAN-ID.....	48
19.3.5.2 Transmission format.....	49
19.3.6 Remote Query.....	49
19.3.7 Configuration of a trigger.....	49
19.3.7.1 CAN-ID.....	49
19.3.7.2 Trigger format.....	50
19.3.8 Status and error codes.....	51
19.3.9 Data types.....	52

1 Read before use

Please read this Operating Manual carefully and keep it handy for future reference. Please note that various components of the sensor and the described software may look somewhat different from those shown in the illustrations in this operating manual.

1.1 Used symbols



Important information about potential hazard to the user



Important information concerning the correct operation of the equipment

1.2 Safety instructions



- Installation and commissioning must only be carried out by suitably qualified specialist personnel.
- Never take measurements on or touch live electrical parts.
- Pay attention to the technical data, storage and operating conditions.

1.3 Designated use



- The equipment must only be operated within the range of the specified technical data.
- The equipment must only be used under the conditions and for the purpose for which it was designed.
- The equipment must not be modified or altered in its construction; otherwise, operational safety and correct functioning cannot be guaranteed.

1.4 Incorrect use

If the equipment is not correctly installed



- it may function in a limited way or not function at all
- it may entail a risk of injury by falling down



Note: The driver is liable for securing his vehicle's load.

If the equipment is not correctly connected



- it may not function
- it may be permanently damaged
- it may entail the risk of an electrical shock

1.5 Guarantee

The guarantee applies for 24 months from date of delivery. The guarantee will not apply if the designated use is violated.

1.6 Brand names

All brand names referred to are subject without limitation to the valid trademark and ownership rights of the respective owner.

2 Scope of delivery

The delivery contains the following components:

MARWIS-UMB



Illustration 1: Marwis-UMB

Cable / Plug

Connection cables and plugs have to be ordered separately. You will find the part numbers in chapter 3.2 Accessories or on our homepage www.lufft.com

Protective housing

In order to protect the MARWIS-UMB from pollution it has to be used in any case with one of the two available protective housings. The respective protective housing has to be ordered separately.
The part numbers will be found in chapter 3.2 Accessories or on our homepage www.lufft.com.

Operating Manual

3 Part numbers

3.1 MARWIS-UMB

8900.U03.....MARWIS-UMB for 1 m (3 ¼ ft) measuring distance to the ground

8900.U04.....MARWIS-UMB for 2 m (6 ½ ft) measuring distance to the ground

8900.U05.....MARWIS-UMB for 0.5 m (1 ¾ ft) measuring distance to the ground

3.2 Accessories

Protective housing short (recommended for mounting on passenger car).....	8900.G01
Protective housing long (recommended for mounting on lorry).....	8900.G02
Assembly kit magnetic bar carrier (horizontal).....	8900.G01H
Assembly kit magnetic bar carrier (vertical).....	8900.G01V
Additional magnetic fastener for 8900.G01H or 8900.G01V.....	8900.G01M
Connection cable, 15 m (49 ¼ ft)	8371.UK015
Connection cable, 5 m (16 ¾ ft) with 12V car adapter for cigarette lighter.....	8900.UK05
Plug without cable ¹	8371.UST1

3.3 Spare parts

Temperature humidity sensor.....	8900.UTFF
----------------------------------	-----------

3.4 Additional documents and software

You can download the following documents and software from the internet on www.lufft.com:

- Operating Manual.....this document
- UMB-Protocol.....Communication protocol for UMB devices
- Firmware.....latest firmware for the equipment

MARWIS App for iOS operating systems can be downloaded from iTunes. The MARWIS-App for Android is available in Google Playstore.

¹ Communication has been tested at a maximum cable length of 15m (50 ft) with a bit rate of 115200 baud

4 Equipment description

In accordance with the demands on road traffic meteorological network sensors are mounted on vehicles. MARWIS-UMB for the detection of water, ice, snow and friction can be installed on vehicles. The distance between the sensor and the road must be either 0.5, 1 m or 2 m (1 ¾ ft , 3 ¼ ft or 6 ½ ft).

The device works with infrared measuring. Four emitting and two receiving diodes capture the reflecting behaviour of the road surface at varying wave lengths. Due to the different spectral properties of various substances – e.g. water and ice – the road state can be deduced from the captured values.

MARWIS-UMB delivers values for road temperature, dew point temperature, ambient temperature and humidity, relative humidity at road temperature, water film height, road state, ice percentage and friction.

With an increasing number of ice particles on the road surface the friction coefficient falls and can thus be of important help when deciding about preventive gritting.

Due to the open interface protocols, MARWIS-UMB can be easily integrated into existing winter maintenance monitoring networks. Similarly, MARWIS-UMB can communicate directly with the control system of gritting vehicles.

The measurement data output supports the following protocols: UMB binary.

4.1 Road surface temperature

The road surface temperature is measured with a non-invasive pyrometer which is fully integrated into the sensor.

4.2 Ambient temperature²

The ambient temperature is the air temperature which is measured by the sensor on the side of the MARWIS-UMB.

4.3 Relative humidity²

Relative humidity indicates the degree to which the air is saturated with water vapour. It changes with temperature since hot air can absorb more vapour than cold air.

4.4 Dew point temperature

The dew point temperature is the temperature where the current partial water vapour pressure equals the saturated vapour pressure, which means that condensation sets in e.g. in the form of fog.

4.5 Relative humidity at road temperature

The calculation of the relative humidity at road temperature is based on the absolute humidity and the road temperature. It can be used as an indicator for impending formation of dew or hoarfrost.

4.6 Water film height

The water film height on the road surface is measured with a non-invasive optical spectroscopy.

2 Only MARWIS-UMB

The water film height is the sum of liquid water and water equivalent of frozen water.

The sensor gives both the water film height on smooth surface and the water film height, which takes into account the water in the pores of the road surface. Via surface type (asphalt, concrete) you determine, which amount of water must be considered in the pores.

4.7 Road condition

The road condition is determined from the measurement of water film height, road surface temperature and ice percentage. The sensor deduces the road conditions of dry, damp, wet, snow / ice, chemical wetness and water + ice.³.

The values which are supposed to be used in the calculation of the road condition can be set, e.g. highest, lowest or average road temperature of the last covered road section. For this purpose, predefined settings are available for selection.

4.8 Ice percentage

With the data from the optical spectroscopy the frozen part of the aqueous solution on the road is determined and delivered as ice percentage.

4.9 Snow Height

The sensor detects the snow height in the field of measurement.



Note: The snow height is an additional information and it is not part of the water equivalent.

4.10 Friction

Friction describes the adhesion of tyres on the road surface. This can be reduced due to ambient conditions such as rain or snow. The value of the friction is scaled between 0.1 and 1.0. High values indicate high adhesion, low values stand for low adhesion. The highest value (1.0) will be achieved when the road is dry whereas the lowest result (0.1) will come up with water on ice.



Note: The grip of a road is determined basically by the texture of its surface. The friction value of the MARWIS-UMB indicates to which degree the maximum possible grip of a specific road is reached, respectively how much it has been reduced by ambient conditions.

Therefore, identical friction values of the MARWIS-UMB on different road surfaces mean different grip.

³ The road condition model is subject to constant improvement. Please check regularly on the availability of firmware updates.

4.11 Sensor technology MARWIS-UMB

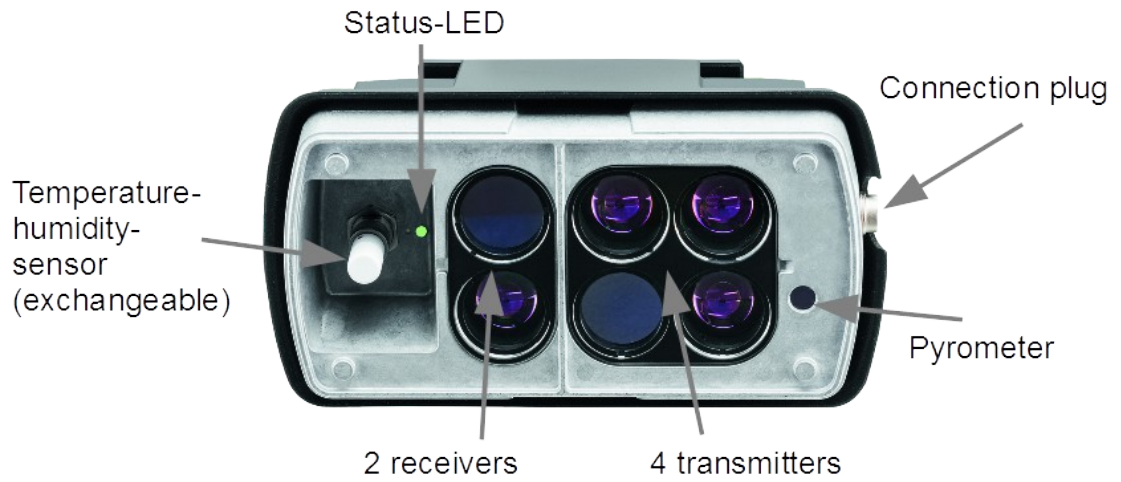

Illustration 2: MARWIS-UMB Components

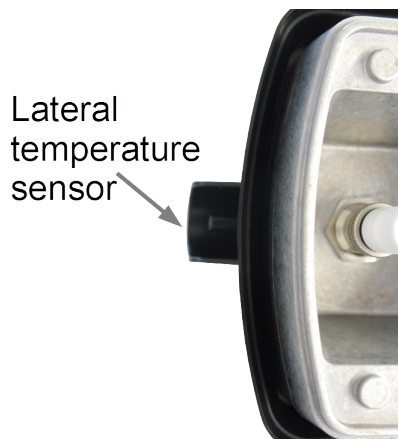

Illustration 3: Lateral temperature sensor (only MARWIS-UMB)

4.12 Status-LED

The device is equipped with a status LED which indicates the current state of the MARWIS-UMB. A blinking LED in any colour means that UMB data transfer is taking place through RS485 or Bluetooth.

Meaning of the LED colours:

Colour	Description
Green	Device status OK, infrared measurement active
Blue	Device status OK, infrared measurement active, active Bluetooth connection
Yellow	Device status OK, Error in infrared measurement (e.g. operating temperature has not yet been reached in the warm up phase) The status channel "measurement status" provides detailed information about the nature of the error.
Magenta	Firmware update active; Don't separate sensor from power supply!
Red	Device error The status channel "device status" provides detailed information about the nature of the error.
Blinking	Data transfer is taking place.

The status of the device and the measurement can also be retrieved on UMB channels 4000 and 4001. The corresponding description can be found in chapter [Fehler: Referenz nicht gefunden Fehler: Referenz nicht gefunden](#) on page [Fehler: Referenz nicht gefunden](#)

5 Generation of measurements

5.1 Current measurement (act)

In accordance with the specified sampling rate, the value of the last measurement is transmitted when the current measurement value is requested.

In order to suppress disturbances which can occur in a mobile operation the measured values in the MARWIS-UMB are filtered over a configurable period of time. Examples for disturbances which can influence the result are described in chapter 16.2, on page 40 of this document. Operation modes

5.2 Normal operation

The MARWIS-UMB is switched on and off by connecting and disconnecting the power supply.

After being switched on it takes a starting time of about 10 seconds before the first measurement values appear. Depending on the operating temperature and on the current ambient temperature a warm up phase of 5 up to 15 minutes may be required before the first plausible values appear. This period can be reduced if the MARWIS-UMB is powered with 24 V (as opposed to 12 V). The state of readiness is indicated by the status LED turning green or blue respectively in case the Bluetooth connection is active. The meanings of the status LED's colours are described in chapter 4.12 on page 12.

6 Measurement output

The measured values are delivered in the UMB binary protocol. You can find an example for a data retrieval and the complete overview of the UMB channels in the appendix.

6.1 Measurements

6.1.1 Road Surface Temperature

Sampling rate..... < 1 second

Units..... °C; °F

UMB Channel	Measurement variable (float32)	Measuring range		
		min	max	unit
100	Road surface temperature	-40.0	70.0	°C
105	Road surface temperature	-40.0	158.0	°F

6.1.2 AmbientTemperature

Sampling rate..... 1 second

Units..... °C; °F

UMB Channel	Measurement variable (float32)	Measuring range		
		min	max	unit
110	Ambient temperature	-50.0	70.0	°C
115	Ambient temperature	-58.0	158.0	°F

6.1.3 Relative Humidity

Sampling rate..... 1 second

Units..... %

UMB Channel	Measurement variable (float32)	Measuring range		
		min	max	unit
210	Relative humidity	0	100	%

6.1.4 Dew point temperature

Sampling rate..... 1 second

Units..... °C; °F

UMB Channel	Measurement variable (float32)	Measuring range		
		min	max	unit
120	Dew point temperature	-50.0	60.0	°C
125	Dew point temperature	-58.0	140.0	°F

6.1.5 Relative humidity at road temperature

Sampling rate.....1 second

Units.....% r.h.

UMB Channel	Measurement variable (float32)	Measuring range		
		min	max	unit
200	Relative humidity at road temperature	-0.0	100.0	%

6.1.6 Water film height

Sampling rate.....100 Hz

Units.....µm, mil, mm

UMB Channel	Measurement variable (float32)	Measuring range		
		min	max	unit
600	Water film height	0.0	6000.0	µm
605	Water film height	0.0	236.2	mil
610	Water film height	0.0	6.0	mm

6.1.7 Water film height on smooth surface

Sampling rate.....100 Hz

Units.....µm, mil, mm

UMB Channel	Measurement variable (float32)	Measuring range		
		min	max	unit
601	Water film height on surface	0.0	6000.0	µm
606	Water film height on surface	0.0	236.2	mil
611	Water film height on surface	0.0	6.0	mm

Channels 601, 606 and 611 do no consider the water in the pores of the road surface.

6.1.8 Road condition⁴

Sampling rate.....10 Hz

Units.....logic coding

UMB Channel	Measurement variable (uint8)	Coding
900	Road condition	0 dry 1 damp 2 wet 3 ice-covered 4 snow-/ice-covered 5 chemically wet 6 water + ice 8 snow-covered 99 undefined

⁴ The road condition model is subject to constant improvement. Please check regularly on the availability of firmware updates.

dry:	no liquid water on the road; water film height below damp threshold
damp:	liquid water on the road; water film height below wet threshold
wet:	liquid water on the road; water film height on or above wet threshold
ice-covered:	frozen water on the road mainly in the form of ice
snow- / ice-covered:	frozen water on the road either in the form of ice or snow; a more precise differentiation is not possible
chemically wet:	the water film height is on or above the damp threshold and the road surface temperature is below 1.5°C (34.7 °F); the formation of ice is inhibited by the presence of de-icing chemicals
water + ice:	water film height is on or above the damp threshold and the road surface temperature is below 1.5°C (34.7 °F) with the formation of ice particles starting;
snow-covered:	frozen water on the road mainly in the form of snow

6.1.9 Ice percentage

Sampling rate.....10 Hz

Units.....%

UMB Channel	Measurement variable (float32)	Measuring range		
		min	max	unit
800	Ice Percentage	0.0	100.0	%

6.1.10 Snow Height

Sampling rate.....10 Hz

Units.....mm

UMB Channel	Measurement variable (float32)	Measuring range		
		min	max	unit
612	Snow Height	0.0	50	mm

6.1.11 Friction

Sampling rate.....10 Hz

Units.....none

UMB Channel	Measurement variable (float32)	Measuring range		
		min	max	unit
820	Friction	0.0	1.0	none

6.2 Additional sensor information

The sensor delivers more information about its state and functioning.

6.2.1 Device status

UMB channel		Measurement variable (uint16)	
4000		Device status	
Bit 0	RESERVED		
Bit 1	Supply voltage status	0	Supply voltage in range
		1	Low voltage detected
Bit 2	Flash status	0	Flash OK
		1	Error on reading / writing to onboard flash
Bit 3	NIR status	0	NIR measurement OK
		1	Error in NIR measurement (see UMB Channel 4001 for details)
Bit 4	Pyro status	0	Pyro measurement OK
		1	Error in pyrometer measurement
Bit 5	TFF status	0	TFF (t/h.r.) measurement OK
		1	Error in TFF (t/h.r.) measurement
Bit 6	Heater temperature measurement status	0	Internal heater temp. measurement OK
		1	Error measuring heater temperature (Heating will be disabled)
Bit 7	RS485 status	0	RS485 communication OK
		1	Error in RS485 communication
Bit 8	Bluetooth status	0	Bluetooth module up and running
		1	Error on Bluetooth communication
Bit 9 - 15	RESERVED		

6.2.2 Measurement status

UMB channel		Measurement variable (uint16)	
4001		Measurement status	
Bit 0	Operating temperature	0	Device temperature in operating range
		1	Invalid operating temperature (status LED: orange)
Bit 1	NIR timeout	0	NIR measurement OK
		1	Timeout error during NIR measurement
Bit 2	Monitor error	0	Monitor measurement OK
		1	Error at monitor measurement (LED defective)
Bit 3	NIR measurement	0	NIR measurement ok
		1	NIR measurement invalid
Bit 4 – 7	RESERVED		
Bit 8	Invalid adjustment profile	0	Adjustment profile valid
		1	Invalid adjustment profile selected; WFH measurement impossible
Bit 9 - 14	RESERVED		
Bit 15	General error	0	No error
		1	Unspecified, general error

7 Mounting

7.1 Hints for mounting MARWIS-UMB

The mounting of the MARWIS-UMB on the vehicle must be fit to be used on the road.

The protective housings 8900.G01 and 8900.G02 are supposed to protect the sensor from turbulences and dirt which could impair the measurement. They do not affect the measuring distance which has to be measured in any case between the sensor face and the road.

It has to be made sure that the field of view of the MARWIS-UMB is directed to the road and not interrupted by vehicle parts. The zone that would be covered if the side parts of the protective housing were extended down to the road should be free of obstacles. The inclination angle of the MARWIS-UMB towards the road must correspond to the one which is given by the protective housing (see illustrations in chapter 14.3).

The MARWIS-UMB should be installed in a way that ensures it cannot be affected by heat from the exhaust fumes of the vehicle.

It should be avoided installing the MARWIS-UMB straight above the tyres track since in this position the risk of spume soiling the glass front of the MARWIS-UMB is elevated which could in turn affect the measurement of the water film height.

7.2 Mounting height

The measuring distance of 1 m or 2 m (3¼ ft or 6½ ft) for the 2 MARWIS-UMB types refer to the distance from the sensor front (glass) to the road. This measuring distance should be observed as exactly as possible. The tolerance which still allows for plausible measurement values amounts to -20 cm / +50 cm (-8 in / + 19¾ in) in case of instrument 8900.U03, -40 cm / +20 cm (-15¾ in / +8 in) for instrument 8900.U04. A more detailed description will follow in the next chapters.

7.2.1 8900.U03, Mounting with short protective housing, angle 20°

Minimal height.....	75 cm..(29 ½ in).....	measuring distance	80 cm..(31 ½ in)
Ideal height.....	96 cm..(37 ¾ in).....	measuring distance	100 cm..(39 ⅜ in)
Maximum height.....	141 cm..(55 ½ in).....	measuring distance	150 cm.....(59 in)

7.2.2 8900.U04, Mounting with short protective housing, angle 20°

Minimal height.....	150 cm.....(59 in).....	measuring distance.....	160 cm.....(63 in)
Ideal height.....	188 cm.....(74 in).....	measuring distance	200 cm..(78 ¾ in)
Maximum height.....	207 cm..(81 ½ in).....	measuring distance	220 cm..(86 ⅝ in)

7.2.3 8900.U05, Mounting with short protective housing, angle 20°

Minimal height.....	33 cm.....(13 in).....	measuring distance	35 cm..(13 ¾ in)
Ideal height.....	47 cm..(18 ½ in).....	measuring distance	50 cm..(19 ¾ in)
Maximum height.....	61 cm.....(24 in).....	measuring distance	65 cm..(25 ⅝ in)

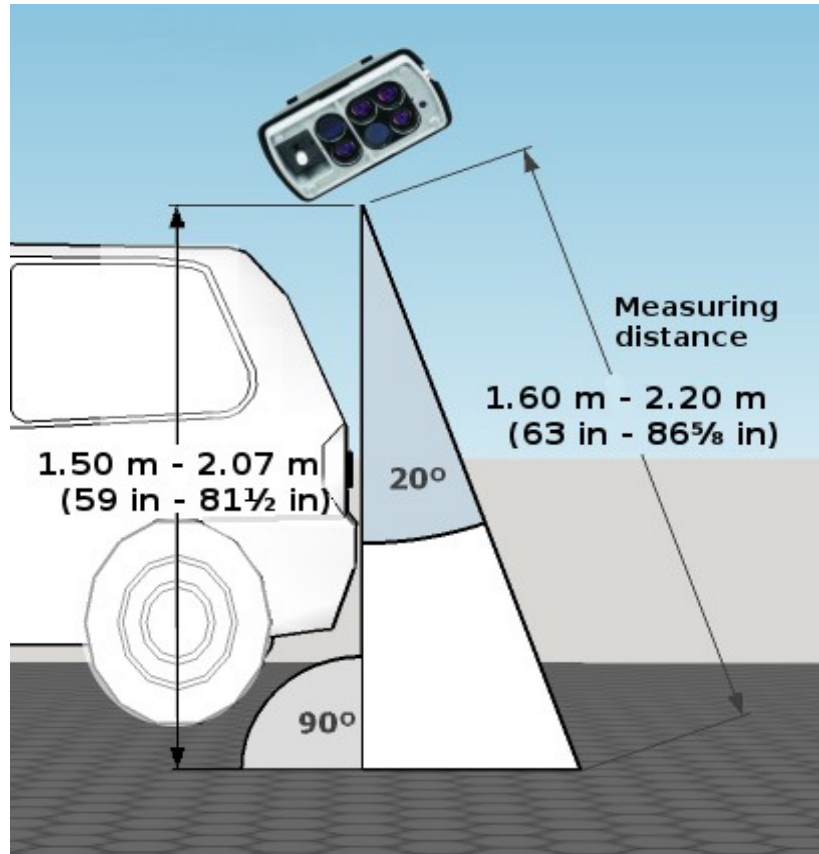

Illustration 4: 8900.U04 Mounting at an angle of 20°

7.2.4 8900.U03, Mounting with long protective housing, angle 10°

Minimal height.....	79 cm..(31 1/8 in).....	measuring distance	80 cm..(31 1/2 in)
Ideal height.....	98 cm..(38 5/8 in).....	measuring distance	100 cm..(39 3/8 in)
Maximum height.....	148 cm..(58 1/2 in).....	measuring distance	150 cm.....(59 in)

7.2.5 8900.U04, Mounting with long protective housing, angle 10°

Minimal height.....	157 cm.....	measuring distance	160 cm.....(63 in)
Ideal height.....	197 cm.....	measuring distance	200 cm..(78 3/4 in)
Maximum height.....	217 cm.....	measuring distance	220 cm..(86 5/8 in)

7.3 Protective housing

The protective housing is supposed to protect the MARWIS-UMB from dirt and turbulences. Furthermore it is equipped with a flange which can be used for fixing it.

7.3.1 Connecting the MARWIS-UMB to the protective housing

Loosen the screws on the upper side of the MARWIS-UMB and take off the plastic stripes.



Illustration 5: Loosen screws on MARWIS-UMB housing

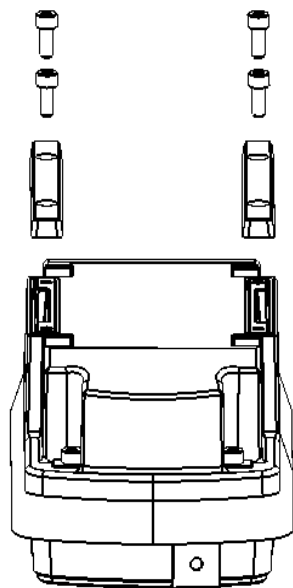

Illustration 6: Preparation for connecting the protective housing



Illustration 7: Fixing stripes and screws

The delivery of the protective housing includes 2 clamp straps for fixing it to the MARWIS-UMB.

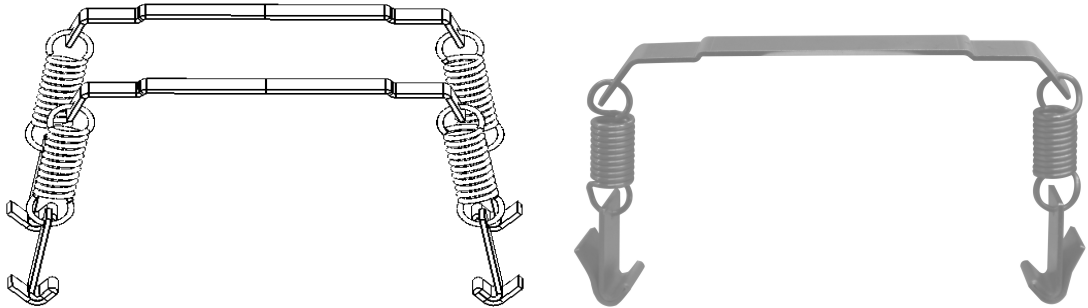

Illustration 8: clamp strap

Place the clamp straps that have come with the protective housing on the MARWIS-UMB so that the profiles of the two clamp straps fit in neatly with the dents on the upper side of the MARWIS-UMB.

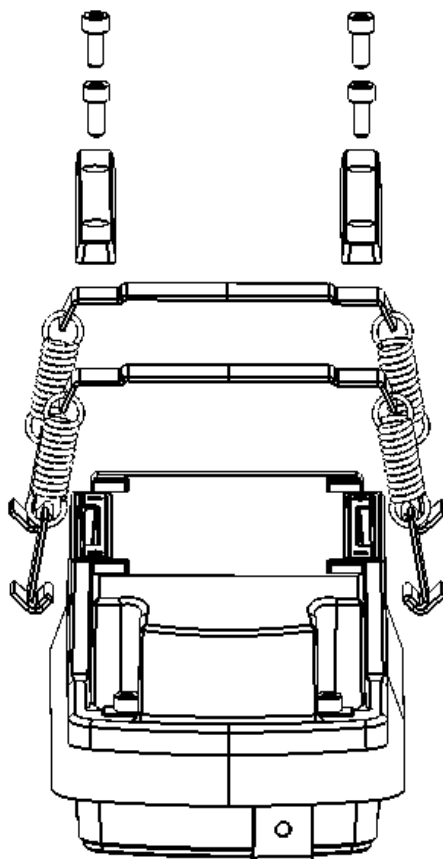

Illustration 9: Placing the clamp straps



Illustration 10: Placing the clamp straps

Mount the plastic bars of the clamping device on the MARWIS-UMB; insert the screws and tighten them.



Illustration 11: Fixing the clamp straps



Illustration 12: Insert screws



Illustration 13: Tighten screws

Put the MARWIS-UMB on the protective housing so that the ends of the clamp straps come close to the hitch of the housing.



Illustration 14: Hitch on protective housing



Illustration 15: Set MARWIS-UMB on protective housing

Press the clamp straps with a screw driver towards the protective housing until they catch the hitch. Now the MARWIS-UMB is connected to the protective housing. First fasten one clamp strap on both sides, then the other one.



Illustration 16: Fasten clamp straps with a screw driver



Illustration 17: Fasten clamp straps with a screw driver

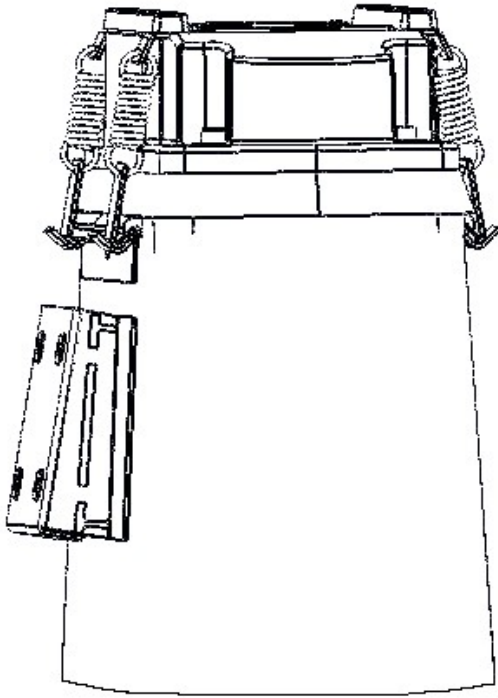

Illustration 18: Protective housing connected



Illustration 19: clamp straps latched

Removing the MARWIS-UMB from the protective housing is easily done by again inserting a screw driver into the ears of the clamp straps. By pressing outwards downwards the connection can be opened.

7.4 Example: Mounting with magnetic bar carrier for horizontal installation and short protective housing



Illustration 20: Mounting on passenger car

7.5 Example: Mounting with magnetic bar carrier for vertical installation and long protective housing



Illustration 21: Vertical mounting (door of a van)

8 Connections

The MARWIS-UMB housing is equipped with an 8-pole screw plug socket which serves for connecting the supply voltage and the RS485 interface. The connection cable has to be ordered separately in the desired length (5 or 15 meters / 49 ¼ ft or 16 ¾ ft).

8.1 Connection plug



III. 22: 8-pole socket

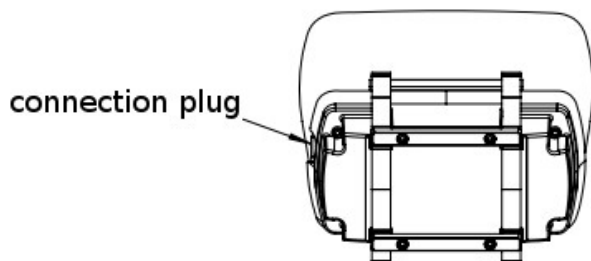

III. 23: Connection plug



III 24: View on solder connection of the cable socket

8.2 Pin assignment

1	pink	CAN-HIGH
2	yellow	RS485_B
3	red	
4	grey	CAN-LOW
5	green	RS485_A
6	blue	
7	white	negative supply voltage
8	brown	positive supply voltage



Note: The shielding of the MARWIS-UMB connection cable has to be connected to the chassis of the vehicle.



Note: The MARWIS-UMB has to be protected with a 5 A fuse

8.3 Supply voltage

The sensor is powered by direct current voltage of 12 – 28 VDC.

With temperatures below -10°C (14 °F) and a power supply of 12V a 12v to 24Vstep up converter should be used in order to allow for the necessary heating performance.

8.4 RS485-interface

The device is equipped with a half duplex 2 wire RS484 interface for configuration, measurement retrieval and firmware update.

The MARWIS-UMB sampling rate can be adjusted in steps of 0.1 s to values between once per 0.1 s and once every 5 seconds. If the data are not retrieved more often than once per second the bit rate of 19200 baud will usually be sufficient. If the sampling rate is higher than that a baud rate of 115200 is recommended.

8.5 Bluetooth connection

For setting up a Bluetooth connection follow the instructions of the producer of the device to which you want to connect the MARWIS-UMB (iPad, Windows-PC...)

Then look for your MARWIS-UMB in the Bluetooth settings. It will register with the first two sections of its serial number.

If you are using the UMB Config Tool select the COM port for communicating with the MARWIS-UMB that has been assigned to your Bluetooth connection during the setup.

9 Commissioning

9.1 Adaption of the sensor

In order to prepare the sensor correctly for the conditions of the surface to be measured (road or tarmac), the unit has to go through an adaptation procedure prior to commissioning.

To this end, the MARWIS-UMB has to be installed on the measuring vehicle in the planned position. The adaption must take place on a dry piece of road and is carried out on a stationary vehicle, i.e. not while moving.

The road cover which is selected for the adaption should be representative for the area in which the MARWIS-UMB is going to be used.

The ambient temperature should be lower than 30°C (86 °F). The adaption must not be carried out in artificial light.

The measurement may contain errors, if the adaption has not been carried out correctly.

The profile of the adaption can be saved in the MARWIS-UMB. Up to 5 different profiles can be stored.

During the adaption, basic settings are configured which depend on the structure of the ground, the measuring angle and the exact measuring distance between the MARWIS-UMB and the road. Therefore, when saving different profiles it makes sense to give them names which allow conclusions on these conditions. E.g. mentioning the vehicle in the profile name can allow conclusions about the installation height during the adaption.

9.1.1 Possible reasons why an adaption may fail

- The ambient temperature exceeds 30 °C (86 °F). In this case the LEDs may become too warm for carrying out a successful adaption.
- The MARWIS-UMB had not been switched on long enough before the adaption was started. About 5 minutes of warm-up time is necessary.
- The ground is not suitable for the adaption (too bright, too dark....)

9.2 Selecting the settings for the road condition model

The settings for the road condition model determine if the interpretation of the current conditions is supposed to be subject to a rather optimistic, pessimistic or neutral point of view. Depending on these settings the values which are selected for the next measurement retrieval will be either the maximum, minimum or average values that have been measured.

Selecting the lowest measured road temperature in combination with the highest values of water film and ice percentage on a trip in winter e.g. would correspond to a rather pessimistic point of view which aims at showing the highest possible risk on a road section.

The values which are selected in the settings for the retrieval of the individual values, are also the ones which are used for calculating road condition and friction.

7 presets are available for selection:

No.	Preset	Road temperature	Water film height	Ice Percentage
0	AVG ⁵	Average	Average	Average
1	Winter 1	Minimum	Maximum	Maximum
2	Winter 2	Average	Average	Maximum
3	Winter 3	Minimum	Average	Maximum
6	Winter 4	Minimum	Average	Average
4	Summer 1	Average	Maximum	Minimum
5	Summer 2	Average	Average	Minimum

9.2.1 Illustration of how the road condition is determined

While measuring MARWIS-UMB detects water film height and ice percentage with a frequency of 100 Hz, i.e. one measured value every 10 ms. Some of these values are filtered out for the suppression of disturbances (see chapter 16.2 page 40), the remaining were analysed statistically (average, min and max values).

With a frequency of 10Hz, i. e. every 100ms, the road temperature is measured.

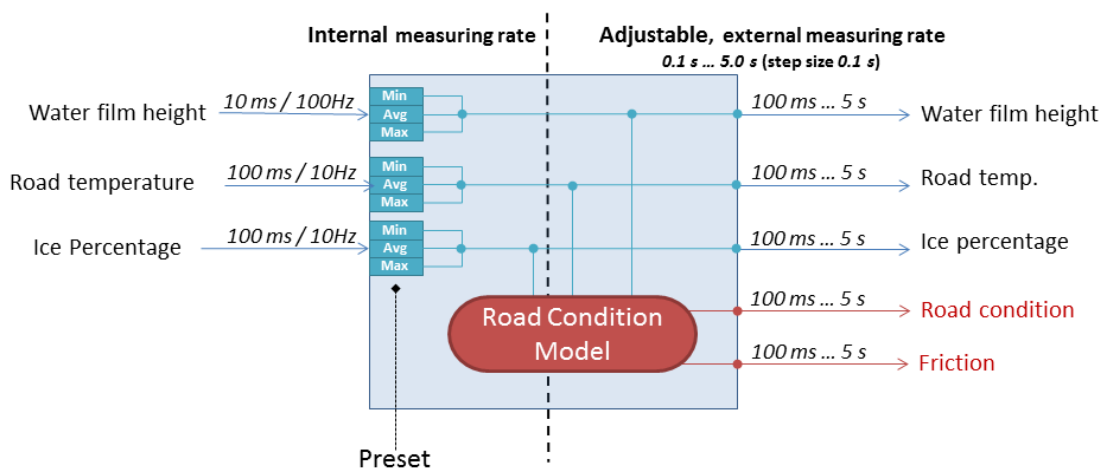

Illustration 25: Settings of the road condition model

For MARWIS-UMB the update rate (external measuring rate) can be set between 100ms and 1s in 100ms steps. So with factory settings MARWIS-UMB calculates new output values every 100ms.

The averaging time can be configured via the 'number of measurements for averaging'. The maximum number for averaging is 60 values.

If this value is set for example to 10 and the default update rate is used, MARWIS-UMB averages over 10 100ms values, that is over 1 second.

5 Factory setting

Sensor	min. update rate	max. update rate	min. step
MARWIS-UMB	100ms (factory setting)	1s	100ms

9.3 Important hints prior to commissioning



Please adhere to the following points:

- Acquaint yourself with the functionality of the UMB-Config-Tool.Net and the MARWIS-App respectively.
- Do not switch on the power supply before the installation has been completed.
- Restarting the MARWIS-UMB after the adaption will not influence the measurements. The latest used adaption profile will be reloaded automatically.
- In a vehicle with a stop-start system the cigarette lighter is usually left without power supply during the starting process. If the MARWIS-UMB receives its power supply from the cigarette lighter in such a car, it will in this case carry out a reset which may lead to data gaps.
- If several MARWIS-UMB are used in the same network, each instrument must receive its own device ID.

10 Carrying out the sensor adaption

10.1 Adaption with the MARWIS-App

The adaption of the sensor can be carried out with the MARWIS-App on the iPad or Android tablet PC or with the program ConfigTool.Net on Windows PC. The exact proceeding is described in the manual / help of the respective app or program.

11 Configuration and test

Configuration can be done with the Windows® PC software ConfigTool.Net or with the apps for Android tablet PC or ipad. The sensor can also be tested and the firmware updated with the aid of this software.

11.1 Factory Settings

The sensor is delivered with the following settings:

Class ID:..... 10 (cannot be modified)
 Device-ID:..... 1 (gives address A001h = 40961d)
 Baud rate:..... 19200
 RS485 protocol:..... UMB binary
 Water film damp threshold:..... 10 µm
 Water film wet threshold:..... 100 µm
 Critical temperature⁶..... 1,5 °C
 Temperature offset..... 0K
 Oberflächentyp..... asphalt
 Measuring interval MARWIS-UMB..... 0,1 s
 Deicer..... NaCl
 Preset of the road condition model..... average



Note: the device ID must be changed if several MARWIS-UMB are operated in one UMB network since each device requires a unique ID. It makes sense to start from ID 1 and continue in ascending order.



Note: Due to the strict master-slave principle no other bus participant must be used as a master as long as the RS485 connection is active since the PC is taking over the master function.



Important note: If the baud rate is changed, after saving the configuration on the sensor, the sensor communicates at the new baud rate. Please make sure that your retrieving system supports the changed baud rate.

6 Below which ice is detected

12 Firmware Update

To keep the sensor in accordance with the latest state-of-the-art, it is possible to carry out a firmware update on site with no need to return the sensor to the manufacturer.

12.1 Update with the MARWIS-App or ConfigTool.Net

The proceeding of how to carry out a firmware update is described in the help function of the MARWIS-App and the PC software ConfigTool.Net respectively.

13 Maintenance



Note: Make sure that the MARWIS-UMB is disconnected from power supply during maintenance / cleaning!

13.1 Cleaning the sensor front glass pane

If the glass pane on the sensor front is soiled, clean it with a damp, wrung out cloth. Dry the pane afterwards with a dry lint-free cloth.

Remove dust and dirt from the housing as well.

Don't use solvents like benzine, thinner, alcohol, kitchen cleaners etc. since these agents can damage the housing and the optical parts.

If you use a chemical cleaning tissue, pay attention to the corresponding instructions.



Note: By no means use a pressure washer for cleaning the MARWIS-UMB.



Don't forget to take off your MARWIS-UMB before driving into a car wash.

13.2 Checking the bolted connections

Please check regularly if all screws and the clamp straps are still fitted tightly.

14 Technical Data

14.1 Device

Power supply:	10 – 28 V DC on the sensor
Power input:	ca. 3 VA without heating, 50 VA with heating ⁷
Protection class:	IP68
Measuring distance	<u>8900.U03</u> 1 m / 3 ¼ ft tolerance: 0.80 m ...1.50 m / 31 ½ in...59 in <u>8900.U04</u> 2 m / 6 ½ ft tolerance: 1.60 m ... 2,20 m / 63 in...86 ⅝ in <u>8900.U05</u> 0.5m / 19 ¾ in tolerance: 0.35 ... 0.65m / 13 ¾ – 25 ½ in
Sensor dimensions	height ca. 110 mm / 4 ⅜ in width ca. 200 mm / 7 ⅞ in depth ca. 100 mm / 3 ⅞ in
Sensor weight	1.7 kg
Storage conditions	
permissible temperature	-40...+70 °C / -40....+158 °F
permissible rel. humidity	0 ... 95 % r.h. non-condensing
permissible height above sea level:	3000 m / 9,843 ft
Operating conditions	
permissible ambient temperature	-40 ... +60 °C / -40...+140 °F
permissible rel. humidity	0 ... 100 % r.h.
RS485 interface, 2 wire, half duplex	
Data bits	8
Stop bit	1
Parity	none
Tri-state	2 bits after stop bit edge
Adjustable baud rates	1200, 2400, 4800, 9600, 14400, 19200 ⁸ , 28800, 57600, 115200
Sampling rate	100 ms.... 5 s, adjustable in steps of 0.1 s ⁹ (MARWIS-UMB)
Bluetooth interface	
Housing	aluminium, plastic
CAN interface	

⁷ With temperatures below -10 °C (14 °F) and a power supply of 12 V a 12 V to 24 V step up converter should be used in order to allow for the necessary heating performance.

⁸ Default setting and baud rate for firmware update

⁹ For sampling rates up to 1/s a bit rate of 19200 baud will usually be sufficient; for higher sampling rates please select 115200 baud.

14.2 Measuring Range / Accuracy

14.2.1 Road Surface Temperature

Principle	optical
Measuring range	-40°C...+70°C / -40....+158 °F
Accuracy	0.8 K at 0°C / 1.44 °R at 32 °F
Resolution	0.1 K / < 1.8 °R

14.2.2 Road Condition¹⁰

Value	Road state
0	dry
1	damp
2	wet
3	ice-covered
4	snow / ice-covered
5	chemically wet
6	water + ice
8	snow covered
99	undefined

14.2.3 Dew point temperature

Principle	passive, calculated out of air temperature and humidity
Measuring range	-50 °C ... + 60 °C / -58 °F... 140 °F
Resolution	0,1 K / < 1.8 °R

14.2.4 Water film

Principle	optical
Measuring range	0 - 6 mm / 0... 0.236 in
Resolution	0.1 µm / < 4 mil
Precision	± 10 % at 0 ... 6 mm water film height on sleek ground ¹¹

14.2.5 Relative humidity at road temperature

Measuring principle	passive, calculated out of absolute air humidity and road surface temperature
Measuring range	0 ... 100%
Resolution	0.1 %

¹⁰ The road condition model is subject to constant improvement. Please check regularly on the availability of firmware updates.

¹¹ Tests for checking the water film height can be carried out on even ground made from sleek not water absorbing material with a minimum reflectivity of 0.5 i.e. 50% of the energy is being reflected. With a distance of 1 -2 m to the MARWIS-UMB the test ground has to be at least 25 x 25 cm in size.

14.2.6 Relative humidity

Measuring principle	capacitive
Measuring range	0 ... 100%
Resolution	0.1 %
Precision	3 % at 40 km/h (25 mph) ¹²

14.2.7 Ambient temperature

Measuring principle	NTC
Measuring range	-40 ... 70 °C
Resolution	0,1 K
Precision	± 0,5 °C from 40 km/h (25 mph) on ¹³

14.2.8 Friction

Measuring range	0 ... 1
Resolution	0.01

14.2.9 Ice percentage

Measuring range	0 ... 100 %
Resolution	1 %

14.2.10 Snow Height

Measuring principle	optical
Measuring range	0 ... 50 mm
Resolution	0.01 mm

¹² In a stable state, i.e. the definite value has been reached and the environment conditions are not subject to strong variations as e.g. when driving in a landscape with quick changes of wood and open space

¹³ If the vehicle is standing still the sensor heating influences the temperature measurement

14.3 Drawings

14.3.1 MARWIS-UMB with short protective housing

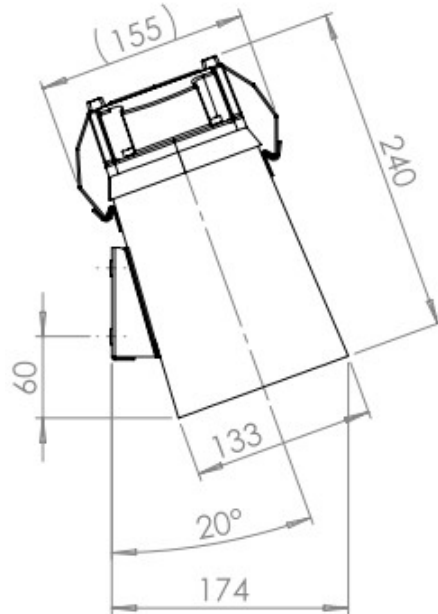

Illustration 26: MARWIS-UMB with short protective housing

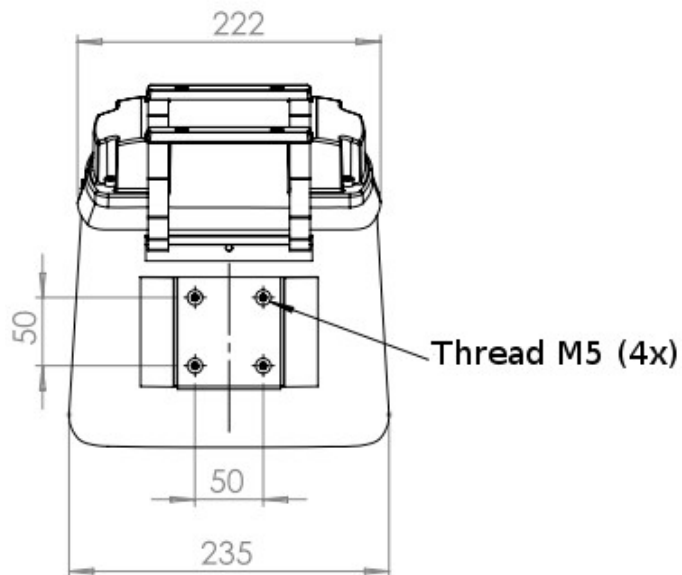

Illustration 27: MARWIS-UMB with short protective housing

14.3.2 MARWS-UMB with long protective housing

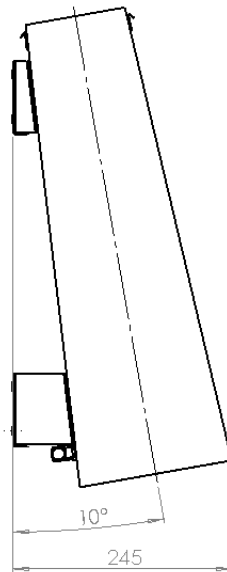

Illustration 28: Long protective housing – lateral view

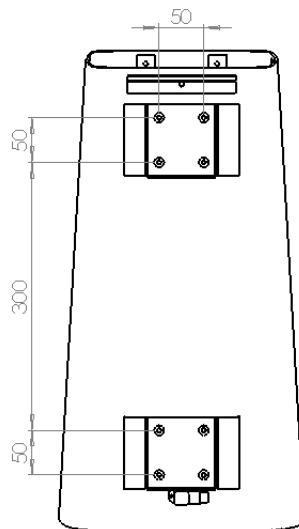

Illustration 29: Long protective housing – back view

15 Declaration of Conformity

15.1 EC Certificate of Conformity

Product: Mobile Road Sensor
Type MARWIS-UMB (Order No. 8900.Uxx)

We herewith certify that the above mentioned equipment complies in design and construction with the below mentioned Directives of the European Union

2011/65/EU RoHS-Directive

2014/53/EU Radio Equipment Directives

Applied harmonised standard:

EN 50591:2010 Technical Documentation

EN 62368-1 Electrical Safety

EN 301489-17 Electromagnetic Compatibility standard for radio equipment

15.2 FCC Compliance statement (US)

Product: Mobile Road Sensor
Type MARWIS-UMB (Order No. 8900.Uxx)

This device contains equipment with the FCC ID: PVH0946.

This device complies with part 15 of the FCC Rules.

Operation is subject to the following two conditions:

- (1) This device may not cause harmful interference, and
- (2) this device must accept any interference received, including interference that may cause undesired operation.

Changes and modifications not expressly approved by manufacturer could void the user's authority to operate the equipment.

15.3 IC Compliance statement (CA)

Product: Mobile Road Sensor
Type MARWIS-UMB (Order No. 8900.Uxx)

This device contains equipment with the IC ID: 5325A-0946.

This device complies with Industry Canada licence-exempt RSS standard(s). Operation is subject to the following two conditions:

- (1) This device may not cause interference, and
- (2) this device must accept any interference received, including interference that may cause undesired operation of the device.

Le présent appareil est conforme aux CNR d'Industrie Canada applicable aux appareils radio exempts de licence. L'exploration est autorisée aux deux conditions suivantes:

- (1) l'appareil ne doit pas produire de brouillage, et
- (2) l'utilisateur de l'appareil doit accepter tout brouillage radioélectrique subi, même si le brouillage est susceptible d'en compromettre le fonctionnement.

16 Disturbances

16.1 Possible errors occurring on the MARWIS-UMB

Error descriptions	Cause / remedy
Device does not allow polling or does not respond	<ul style="list-style-type: none"> • Check status-LED • Check supply voltage • Check interface connection • incorrect device-ID → check ID; devices are delivered with ID 1.
Device delivers implausible values	<ul style="list-style-type: none"> • Check status-LED • Check for compliance with the sensor installation instructions • Has the device been commissioned correctly? Repeat if necessary • Has the correct adaption profile been selected?
Device transmits error value 2bH (43d)	Error in measurement; value cannot be determined
Device transmits error value 24h (36d)	A channel was requested that is not available on this device.
Device transmits error value 28h (40d)	Device is in initialization phase after start-up → wait until first measurement is complete
Device transmits error value 31h (49d)	Faulty adaption; carry out an adaption on representative dry ground
Device transmits error value 50h (80d)	Device is being operated above the specified measuring range.
Device transmits error value 51h (81d)	Device is being operated below the specified measuring range.
Device transmits error value 55h (85d)	The device is unable to execute a valid measurement due to the ambient conditions.
Device transmits an error value which is not listed here.	There may be several reasons for this behaviour → contact the manufacturer's technical support team.

16.2 Interfering factors which can influence the measurement result

- Lengthwise oriented road markings, tarmac seams
Due to their longitudinal orientation these disturbances can adopt an all but static character. Disturbances from road markings which lie crosswise towards the direction of travel are noted shorter when running over them and can therefore be filtered out for the resulting value.
- Tunnel lighting
- Longer persisting disturbances (like road markings, tarmac seams, manhole covers....) due to the vehicle not moving
- Extreme rainfall
- Cast shadow (in sunny weather, shadow e.g. from trees, quick alternation between sunny and shady locations)
- Heat from exhaust fumes

- Dirt on the MARWIS-UMB front glass pane, e.g. due to spume on wet roads
- Very dark road surface (new blacktop – MARWIS-UMB)

17 Disposal

17.1 Within the EU

The device must be disposed of in accordance with European Directives 2002/96/EC and 2003/108/EC (waste electrical and electronic equipment). Waste equipment must not be disposed of as household waste! For environmentally sound recycling and the disposal of your waste equipment please contact a certified electronic waste disposal company.

17.2 Outside the EU

Please comply with the applicable regulations for the proper disposal of waste electrical and electronic equipment in your respective country.

18 Repair / Corrective Maintenance

Please arrange for any faulty equipment to be checked and, if necessary, repaired by the manufacturer exclusively. Do not open the equipment and do not under any circumstances attempt to carry out your own repairs.

In the event of a repair please contact:

OTT HydroMet Fellbach GmbH

Gutenbergstraße 20
70736 Fellbach
Germany

Phone: +49 711 51822-0

Hotline: +49 711 51822-52

Fax: +49 711 51822-41

E-Mail: met-info@otthydromet.com

Or your local distributor.

18.1 Technical Support

Our hotline is available for technical questions via the following e-mail address:

met-support@otthydromet.com

You can also consult frequently asked questions at www.lufft.com

(menu header: Support → FAQs).

19 Appendix

19.1 Channel List Summary

The channel assignment described here applies to online data requests in UMB protocol

UMB Channel				Measurement Variable (float32)	Measuring Range		
act	Min	Max	avg		Min	Max	unit
Road surface temperature							
100				Road surface temperature	-40.0	70.0	°C
105				Road surface temperature	-40.0	158.0	°F
Dew point temperature							
120				Dew point temperature	-50.0	60.0	°C
125				Dew point temperature	-58.0	140.0	°F
Relative humidity at road temperature							
200				Relative humidity at road temperature	0.0	100.0	%
Water film height							
600				Water film height	0.0	6000.0	µm
605				Water film height	0.0	78.7	mil
610				Water film height	0.0	6.0	mm
Water film height on surface¹⁴							
601				Water film height on surface	0.0	6000.0	µm
606				Water film height on surface	0.0	78.7	mil
611				Water film height on surface	0.0	6.0	mm
Snow height							
612				Snow height	0.0	50.0	mm
Road condition							
900				Road condition (uint8)	0 dry 1 damp 2 wet 3 ice-covered 4 snow-/ice-covered 5 chemically wet 6 water + ice 8 snow-covered 99 undefined		
Ice percentage							
800				Ice percentage	0.0	100.0	%
Friction							
820				Friction	0.0	1.0	none
Device status							
4000					0	1	

¹⁴ Channels 601, 606 and 611 do not consider the water in the pores of the road surface.

Bit 0	RESERVED		
Bit 1	Supply voltage status	0	Supply voltage in range
		1	Low voltage detected
Bit 2	Flash status	0	Flash OK
		1	Error on reading / writing to onboard flash
Bit 3	NIR status	0	NIR measurement OK
		1	Error in NIR measurement (see UMB Channel 4001 for details)
Bit 4	Pyro status	0	Pyro measurement OK
		1	Error in pyrometer measurement
Bit 5	TFF status	0	TFF (t/h.r.) measurement OK
		1	Error in TFF (t/h.r.) measurement
Bit 6	Heater temperature measurement status	0	Internal heater temp. measurement OK
		1	Error measuring heater temperature (Heating will be disabled)
Bit 7	RS485 status	0	RS485 communication OK
		1	Error in RS485 communication
Bit 8	Bluetooth status	0	Bluetooth module up and running
		1	Error on Bluetooth communication
Bit 9 - 31	RESERVED		
Measurement status			
4001		0	1
Bit 0	Operating temperature	0	Device temperature in operating range
		1	Invalid operating temperature (status LED: orange)
Bit 1	NIR timeout	0	NIR measurement OK
		1	Timeout error during NIR measurement
Bit 2	Monitor error	0	Monitor measurement OK
		1	Error at monitor measurement (LED defective)
Bit 3	NIR measured value	0	NIR value OK
		1	NIR value invalid
Bit 4 – 7	RESERVED		
Bit 8	Invalid adjustment profile	0	Adjustment profile valid
		1	Invalid adjustment profile selected; WFH measurement impossible
Bit - - 30	RESERVED		
Bit 31	General error	0	No error
		1	Unspecified, general error

19.2 Communication in binary protocol

Only one example of an online data request is described in this operating manual. Please refer to the current version of the UMB protocol for all commands and the exact operation mode of the protocol (available for download at www.lufft.com)



Note: Communication with the sensor takes place in accordance with the master-slave principle, i.e. there must only be ONE requesting unit in a network.

19.2.1 Framing

The data frame is constructed as follows:

1	2	3-4	5-6	7	8	9	10	11... (8 + len) optional	9 + len	10 + len 11+ len	12 + len
SOH	<ver>	<to>	<from>	<len>	STX	<cmd>	<verc>	<payload>	ETX	<cs>	EOT

- SOH Control character for the start of a frame (01h); 1 byte
- <ver> Header version number, e.g.V 1.0 <ver> = 10h = 16d; 1 byte
- <to> Receiver address , 2 bytes
- <from> Sender address, 2 bytes
- <len> Number of data bytes between STX and ETX; 1 byte
- STX Control character for the start of payload transmission (02h); 1 byte
- <cmd> Command; 1 byte
- <verc> Version number of the command; 1 byte
- <payload> data bytes; 0 – 210 bytes
- ETX Control character for the end of payload transmission (03h); 1 byte
- <cs> Check sum, 16 bit CRC; 2 bytes
- EOT Control character for the end of the frame (04h); 1 byte
- Control characters: SOH (01h), STX (02h), ETX (03h), EOT (04h).

19.2.2 Addressing with Class and Device ID

Addressing takes place by way of a 16 bit address. This breaks down into a Class ID and a Device ID.

Address (2 bytes = 16 bit)			
bits 15 – 12 (upper 4 bits)		bits 11 – 8 (middle 4 bits)	bits 7 – 0 (lower 8 bits)
Klassen-ID (0 bis 15)		Reserve	Geräte-ID (0 - 255)
0	Broadcast		0 Broadcast
10	Mobile road sensor		1 – 255 Available
15	Master or control devices		

ID = 0 is provided as broadcast for classes and devices. Thus it is possible to transmit a broadcast on a specific class. However, this only makes sense if there is only one device of the respective class on the bus, or in case of a command, e.g. reset.

19.2.3 Example for creating addresses

If e.g. a MARWIS-UMB shall be addressed with Device ID 001 this works as follows:

Class ID for MARWIS-UMB is 10d = Ah

Device ID is e.g. 001d = 01h

By putting together the class ID and the device ID the resulting address is A001h = (40961d)

19.2.4 Example online data query

Recording of a binary request with "online data query" (**23h**) as an example for retrieving the current road surface temperature (channel **100**)

Request 23h_{10h}[<channel>²]

<channel>² designates the channel number

Response 23h_{10h}[00h, <channel>², <type>, <value>ⁿ]

<type> designates the data type of the output; the length of <value> depends on it

<value>ⁿ the requested value

Comment: The specifications of the channel numbers, which are needed for transmission as well as the transferred value and its format can be found in the device description.

Request

01 10 01 A0 01 F0 04 02 **23 10 64 00** 03 BE F8 04

Response

01 10 01 F0 01 A0 0A 02 **23 10 00 64 00 16 C3 D8 C2 41** 03 BA 2C 04

Interpretation of the response:

<status> = 00h device ok. (≠ 00h is an error code)

<channel>² 0064h = 100d = road surface temperature

<type> = 16h = float (4 bytes, IEEE format)

<value>ⁿ = 41C2D8C3h = 2.43558406829834E+0001 = 24,36°C

19.2.5 Example online data query multiple channels

Recording of a binary request with “online data query multiple channels” (**2Fh**) for reading the current road surface temperature (channel **100**) and road condition (channel **900**) = **2** channels

Request $2Fh_{10h} [\langle \text{number} \rangle, \langle \text{channel} \rangle^{2 \times \langle \text{number} \rangle}]$

$\langle \text{number} \rangle$ number of the requested channels

$\langle \text{channel} \rangle^2$ designates the channel numbers; channel **100** and channel **900**

Response $2Fh_{10h} [00h, \langle \text{number} \rangle, \{ \langle \text{sub-len} \rangle, 00h, \langle \text{channel} \rangle^2, \langle \text{type} \rangle, \langle \text{value} \rangle^{n \times \langle \text{number} \rangle} \}]$

$\langle \text{sub-len} \rangle$ designates the number of bytes following in this sub-telegram; if the subsequent status byte displays, for example 'Value Overflow', $\langle \text{type} \rangle$ and $\langle \text{value} \rangle^n$ are omitted and the next channel follows

$\langle \text{type} \rangle$ designates the data type of the output; the length of $\langle \text{value} \rangle$ depends on it

$\langle \text{value} \rangle^n$ the requested value

Comment: The specifications of the channel numbers, which are needed for transmission as well as the transferred values and their formats can be found in the device description. A maximum of 20 channels can be requested.

Request

01 10 01 A0 01 F0 07 02 **2F 10 02 64 00 84 03** 03 C1 26 04

Response

01 10 01 F0 01 A0 13 02 **2F 10 00 02 08 00 64 00 16 CB 3D A5 41 05 00 84 03 10 01** 03 3F 77 04

19.2.6 Example online data query multiple channels V1.1

Description: This command allows to poll several channels with one call. For each channel one sub-telegram is delivered. A new feature is that there are 2 request telegrams for this call. In the first one (1st call) the requested channels are defined and stored internally, with the other one (from the 2nd call on) the channels which were requested in the first call are delivered again. The answers are identical on both calls. The second call is recommended if the same values are requested again and again at a high measuring frequency.

1st Call

Request $2Fh_{11h} [\langle \text{number} \rangle, \langle \text{channel} \rangle^{2 \times \langle \text{number} \rangle}]$

$\langle \text{number} \rangle$ number of the requested channels

$\langle \text{channel} \rangle^2$ gibt die Kanalnummern an

From 2nd call on:

Request $2Fh_{11h} \text{ 00h}$

Response: $2Fh_{11h} [00h, \langle \text{number} \rangle, \{ \langle \text{sub-len} \rangle, 00h, \langle \text{channel} \rangle^2, \langle \text{type} \rangle, \langle \text{value} \rangle^{n \times \langle \text{number} \rangle} \}]$

$\langle \text{number} \rangle$ number of channels requested in the 1st call

$\langle \text{sub-len} \rangle$ designates the number of bytes following in this sub-telegram; if the subsequent status byte displays, for example 'Value Overflow', $\langle \text{type} \rangle$ and $\langle \text{value} \rangle^n$ are omitted and the next channel follows

$\langle \text{type} \rangle$ designates the data type of the output; the length of $\langle \text{value} \rangle$ depends on it

<value>ⁿ requested value

Example: Retrieval of 3 measurement values

Channel 100 (0064h): Road temperature in °C

Channel 600 (0258h): water film height in µm

Channel 900 (0384h): Road condition

1st Request:

01 10 01 A0 00 F0 09 02 2F 11 03 64 00 58 02 84 03 03 69 24 04

Response:

01 10 00 F0 01 A0 1C 02 2F 11 00 03 08 00 64 00 16 8F BB AA 41 08 00 58
02 16 57 97 E1 42 05 00 84 03 10 00 03 D8 1A 04

Subsequent requests:

01 10 01 A0 00 F0 03 02 2F 11 00 03 24 29 04

Response:

01 10 00 F0 01 A0 1C 02 2F 11 00 03 08 00 64 00 16 5D 67 AD 41 08 00 58
02 16 D1 D1 E1 42 05 00 84 03 10 00 03 BD 25 04

19.3 CAN Protocol (Version 1.0)

19.3.1 General remarks

All Marwis measuring channels can communicate over the CAN interface. Each value will be sent in its own CAN telegram.

In order to transfer a measured value it is either possible to send a remote telegram which will cause the value to be transferred once or to configure a trigger so that the value is sent automatically time and time again. In this latter case the system will check once every 10 ms if a value is supposed to be transferred. The configured triggers of the CAN data transmission are stored permanently, i.e. need to be configured only once when commissioning a MARWIS-UMB.

Each end of the CAN bus should be terminated by a 120 Ohm resistance.

19.3.2 Pin assignment

Pin assignment of the CAN interface on the 8 pole screw plug socket

Pin 1: CAN-High

Pin 4: CAN-Low

19.3.3 CAN-Parameter

The bitrate is 500 kBps.

Extended CAN-IDs (EID) are used.

19.3.4 Data format and byte order in the communication protocol

LONG: LowLowByte LowHighByte HighLowByte HighHighByte

INT: LowByte HighByte

FLOAT: Acc. to IEEE format (4bytes)

19.3.5 Data transmission

19.3.5.1 CAN-ID

Every value will have its own CAN ID. The default values correspond to the UMB value numbers. Since extended CAN IDs are used, the IDE bit is set in addition.

Examples:

Value	Value number (dez. / hex)	11 Bit Identifier (hex)	IDE	18 Bit Identifier (hex)	RTR	CAN-ID (extended)
Road temperature in °C	100d = 0x0064h	0x000	1	0x00064	0	0x00000064
Water film height in µm	600d = 0x0258h	0x000	1	0x00258	0	0x00000258
Road state	900d = 0x0384h	0x000	1	0x00384	0	0x00000384

19.3.5.2 Transmission format

The first data byte contains a status byte (see chapter 19.3.8) which indicates if a valid value is available. If the status is not OK no more data will follow.

If the status is OK (0x00h) it will be followed by the second data byte which specifies the data type in which the value is released (see chapter 19.3.9).

Depending on the data type 1 – 4 byte with measured values will follow from the third data byte on.

Examples:

11 Bit Identifier (hex)	IDE	18 Bit Identifier (hex)	RTR	Data Length Code	Data byte (hex)			Description
					1 Status	2 Typ	3 - 6 Messwert	
0x000	1	0x00064	0	1	0x54	-		Road temperature: no valid value
0x000	1	0x00258	0	6	0x00	0x16	0x00 0x00 0x00 0x00	Water film height is 0
0x000	1	0x00384	0	3	0x00	0x10	0x01	Road state: 1 (humid)

19.3.6 Remote Query

Marwis supports remote value queries. Following the CAN specifications the CAN ID corresponds to the CAN ID which is used for transmitting the corresponding value with additionally set RTR bit.

The required value is transferred instantly one time only.

Examples:

Value	Value number (dez. / hex)	11 Bit Identifier (hex)	IDE	18 Bit Identifier (hex)	RTR	CAN-ID (extended)
Road temperature in °C	100d = 0x0064h	0x000	1	0x00064	1	0x00000064
Water film height in µm	600d = 0x0258h	0x000	1	0x00258	1	0x00000258
Road state	900d = 0x0384h	0x000	1	0x00384	1	0x00000384

19.3.7 Configuration of a trigger

If a value is supposed to be transferred several times, a trigger can be configured which defines under which circumstances the value is supposed to be sent. Every value can have a trigger of its own.

In the default settings no values will be transferred.

19.3.7.1 CAN-ID

The configuration of every value trigger has its own CAN ID. The default settings correspond to the CAN IDs of the value transfer with additionally set lowest value bit of the 11 bit identifier.

Examples:

Value	Value number (dez. / hex)	11 Bit Identifier (hex)	IDE	18 Bit Identifier (hex)	RTR	CAN-ID (extended)
Road temperature in °C	100d = 0x0064h	0x001	1	0x00064	0	0x00040064
Water film height in µm	600d = 0x0258h	0x001	1	0x00258	0	0x00040258
Road state	900d = 0x0384h	0x001	1	0x00384	0	0x00040384

To get the CAN-ID:

The CAN-ID is set together by 18 bit + 11 bit identifier. Example road temperature:

	11 Bit	18 Bit
binär	0 0000 0000 01	00 0000 0000 0110 0100
hexadezimal	0x00 0x04	0x00 0x64

19.3.7.2 Trigger format

The first data byte of the trigger telegram indicates the trigger type. Depending on the type there will be possible parameters that are indicated from the 2nd data byte on.

Trigger	Data Length Code	Data byte (hex)		Parameter	
		1 Type	2 – 5 Parameter	Data type	Description
none	1	0x00	-	-	-
time	5	0x01	4 Byte	unsigned long	Intervall in ms
difference	1	0x02	-	-	-
minimum	2 - 5	0x03	1 – 4 Byte	Same as value	Limit value
maximum	2 - 5	0x04	1 – 4 Byte	Same as value	Limit value

Trigger type = 0:

In case no trigger is specified the corresponding value will not be transferred.

Trigger type = 1:

The time trigger will have the value transferred in the specified interval. Take into account that the trigger check takes place only once every 10 ms so that it makes sense to specify an interval which is a multiple of 10 ms. Other intervals will be brought up to a round figure, e.g. a specified interval of 111 ms will lead to a value transfer every 120 ms.

Trigger type = 2:

The trigger “difference” will have the value transferred each time the current value differs from the previous one. This trigger only makes sense for measuring data whose value changes rarely, e.g. system states.

Trigger type = 3:

Trigger type = 4:

The triggers “miniumum” and “maximum” will have the corresponding value transferred only if it exceeds or falls below the specified limit value. The limit value has to be described in the same data format and with the same unit that are used for the transfer of the measured value.

Examples:

11 Bit Identifier (hex)	IDE	18 Bit Identifier (hex)	RTR	Data Length Code	Data byte (hex)		Description
					1 Typ	2 – 5 Parameter	
0x001	1	0x00064	0	1	0x00		The road temperature is not transmitted (any more) Die Fahrbahntemperatur wird nicht (mehr) übertragen
0x001	1	0x00258	0	5	0x01	0x64 0x00 0x00 0x00	The water film height is transmitted once every 100 ms (100d = 0x64h)
0x001	1	0x00384	0	1	0x02		The road state is transmitted each time its value changes

19.3.8 Status and error codes

Each value telegram contains a status byte which indicates if the transmitted value is ok or which error in the device prevents the value from being detected / transmitted.

Codes:

<status>	Define	Description
00h (0d)	OK	Kommando successful, no error
24h (36d)	UNGLTG_KANAL	Invalid channel; CAN ID not assigned to any channel
28h (40d)	BUSY	Device not ready, e.g. initialising, calibrating
29h (41d)	LOW_VOLTAGE	Undervoltage
2Ah (42d)	HW_ERROR	Hardware error
2Bh (43d)	MEAS_ERROR	Error in the measurement
2Ch (44d)	INIT_ERROR	Error in the device initialisation
2Dh (45d)	RTOS_ERROR	Error in the operating system
30h (48d)	E2_DEFAULT_KONF	Error in the configuration. Defaultl configuration was loaded.
31h (49d)	E2_CAL_ERROR	Error in the adjustment / the adjustment is invalid. No measurement possible.
32h (50d)	E2_CRC_KONF_ERR	CRC error when loading the configuration. Default configuration was loaded.
33h (51d)	E2_CRC_KAL_ERR	CRC error when loading the adjustment data; no measurement possible.
34h (52d)	ADJ_STEP1	Adjustment step 1
35h (53d)	ADJ_OK	Adjustment OK
36h (54d)	KANAL_AUS	Channel deactivated

<status>	Define	Description
50h (80d)	VALUE_OVERFLOW	Measured value (+Offset) are out of the specified range.
51h (81d)	VALUE_UNDERFLOW	
52h (82d)	CHANNEL_OVERRANGE	Measured value (physically) is out of the measuring range (e.g. ADC overrange)
53h (83d)	CHANNEL_UNDERRANGE	
54h (84d)	DATA_ERROR	Data error in the measured values or no valid data available.
55h (85d)	MEAS_UNABLE	Device / sensor cannot carry out a valid measurement due to ambient conditions.
F0h - FEh	Do not use!!	Reserved range e.g. for z.B. LCOM
FFh (255d)	UNBEK_ERR	Unknown error

19.3.9 Data types

This protocol uses the following data types for the measured values:

<type>	Type Name	Define	Bytes	Range
10h (16d)	unsigned char	UNSIGNED_CHAR	1	0 ... 255
11h (17d)	signed char	SIGNED_CHAR	1	-128 ... 127
12h (18d)	unsigned short	UNSIGNED_SHORT	2	0 ... 65.535
13h (19d)	signed shor	SIGNED_SHORT	2	-32.768 ... 32.767
14h (20d)	unsigned long	UNSIGNED_LONG	4	0 ... 4.294.967.295
15h (21d)	signed long	SIGNED_LONG	4	-2.147.483.648 ... 2.147.483.647
16h (22d)	float	FLOAT	4	$\pm 1.18E-38$... $\pm 3.39E+38$ (7 digits)
17h (23d)	double	DOUBLE	8	$\pm 2.23E-308$... $\pm 1.79E+308$ (15 digits)

Remark: float and double in IEEE format

**G. LUFFT Mess- und
Regeltechnik GmbH**

Lufft Germany:

Fellbach Office:

Postal Address:
Gutenbergstrasse 20
D-70736 Fellbach

Address:

P.O. Box 4252
D-70719 Fellbach
Tel.: +49 (0)711 51822-0
Fax: +49 (0)711 51822-41
www.lufft.com
info@lufft.de

Berlin Office:

Oderstr. 59
D-14513 Teltow
Tel.: +49 (0)711 51822-831
Fax: +49 (0)711 51822-944

a passion for precision · passion pour la précision · pasión por la precisión · passione per la precisione ·

Lufft North America:

Lufft USA, Inc.

820 E Mason St #A
Santa Barbara, CA 93103
Tel.: +01 919 556 0818
Fax: +01 805 845 4275
E-Mail: sales@lufftusainc.com
www.lufft.com

Lufft China:

Shanghai Office:

Lufft (Shanghai)
Measurement & Control
Technology Co., Ltd.
Room 507 & 509, Building No.3,
Shanghai Yinshi Science and
Business Park,
No. 2568 Gudai Road,
Minhang District,
201199 Shanghai, CHINA
Tel: +86 21 5437 0890
Fax: +86 21 5437 0910
E-Mail: china@lufft.com
www.lufft.cn

Beijing Office:

B501 Jiatai International Mansion
No. 41 East 4th Ring Road,
Chaoyang District,
100025 Beijing, CHINA
Tel: +86 10 65202779
Fax: +86 10 65202789
E-Mail: china@lufft.com

