

Installation instructions
**Air drying unit for Bubble
Sensor Ott CBS 500**

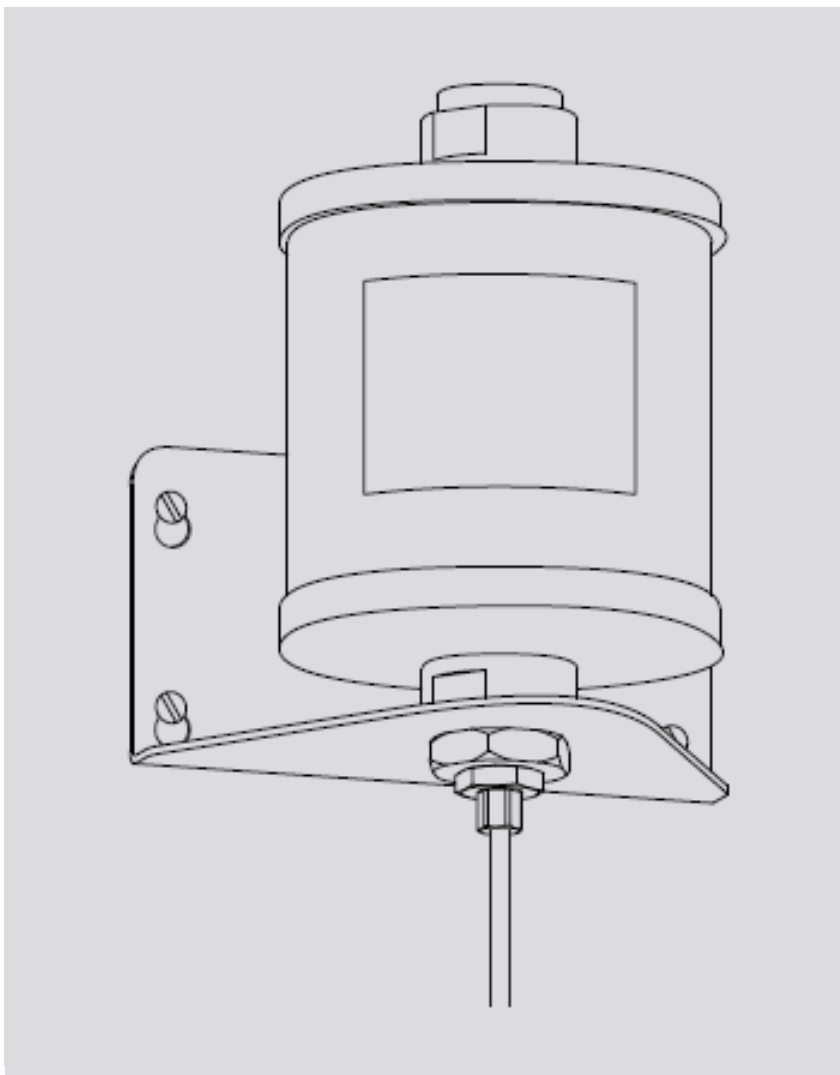

English

1 Scope of supply

- ▶ **Air drying unit**
 - 1 air drying unit with 400 gram drying medium, air humidity indicator and mounting bracket for wall mounting
 - 2 m connection tube
 - 1 screw-in connection with sealing ring
 - 4 wood screws 6x80 with wall plugs S8
 - 1 installation instructions

2 Order numbers

- | | | |
|-------------------------------|---|----------------|
| ▶ Air-drying unit | Air drying unit for Ott CBS 500 bubble sensor with 30 meter measuring range | 63.200.030.3.2 |
| ▶ Consumable materials | Drying medium refill pack, 400 gram | 97.100.320.9.5 |

3 Introduction

Due to the high bubble pressure, the Ott CBS 500 bubble sensor with 30 meter measuring range requires dried intake air. Otherwise, there is the danger, particularly with high humidity in the surrounding air and with temperature differences along the measuring tube, that water condenses in the measuring tube and the measuring tube is blocked by the formation of water drops. In the same way, under unfavorable conditions, icing can occur inside the Ott CBS 500.

In order to dry the intake air, the Ott CBS 500 is provided with an air-drying unit. The air-drying unit is filled with a strongly hygroscopic drying medium that reliably reduces the humidity of the air sucked in from the surroundings. The air-drying unit is additionally equipped with an air humidity indicator (SMD – Humitector). This shows the relative air humidity inside using four colored fields. If a specific air humidity is reached, e.g. 20 %, the color of the relevant colored field changes from blue to pink. Once the absorptive capacity of the drying medium has been reached, replacement is fast and simple.

The air-drying unit can also be used in an Ott CBS 500 with 15 meter measuring range. This is appropriate in cases where the surrounding air has constantly high humidity and/or with large temperature differences along the course of the measuring tube.

4 Installation

Please ensure that the following points are noted during installation

- ▶ The connection tube must be kept dry!
- ▶ Do not install the air-drying unit in hermetically sealed control cabinets!
- ▶ Only install in a vertical position (see Figure)!
- ▶ Install in an area that has as much protection against humidity as possible!
Do not expose the air-drying unit to rain or dripping water!
- ▶ Leave the transport seal on the air-drying unit until installation!

How to install the air-drying unit:

- Attach the aluminum bracket for the air-drying unit to a suitable surface using at least 2 screws (wood screws and wall plugs supplied). Do not fully tighten the screws to allow the air-drying unit to be detached for maintenance (slots).
- Separate the Ott CBS 500 from the electrical supply (pull out screw terminal strip).
- Carefully screw out the intake filter of the Ott CBS 500 using a screwdriver (size 9). If necessary, hold the hex nut still with an open-ended wrench (size 13)! The intake filter is no longer needed.
- Screw the screw-in connection with sealing ring into the Ott CBS 500 and tighten firmly by hand.
- Remove the transport seal from the air-drying unit.
- Push the cap nut onto the connection tube.
- Push the connection tube onto the Ott CBS 500 and onto the nipple of the screw-in connector of the air-drying unit as far as it goes.
- Screw on the cap nut and tighten firmly by hand.
- Reconnect electrical supply.

Fig. 1: Connection schematic of the air drying unit on the Ott CBS 500.

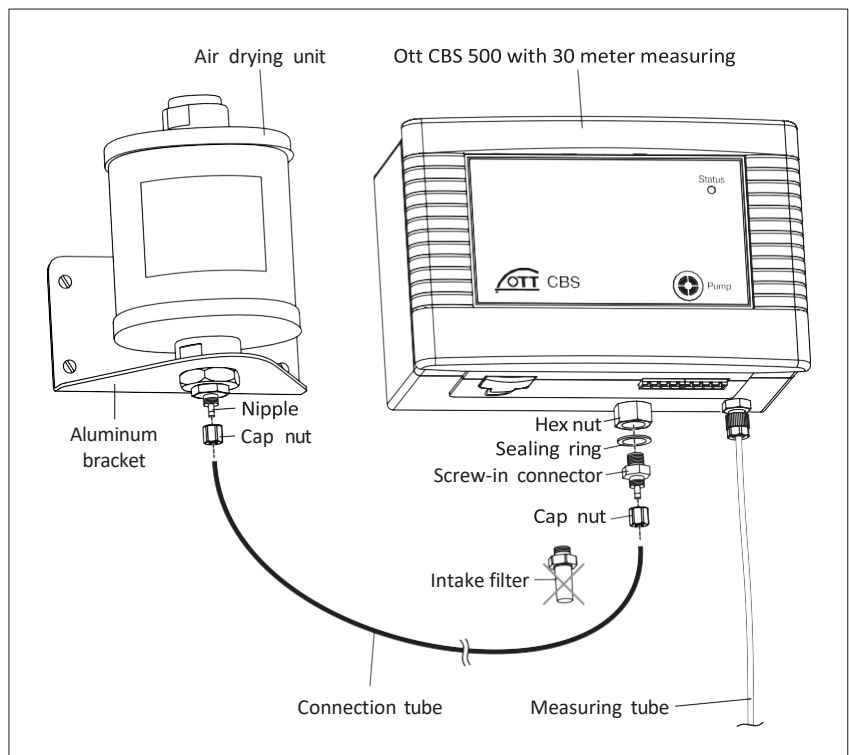

5 Maintenance

- Regularly check the air humidity indicator: at least every 12 months: the drying medium should be replaced once the "30 %" color field has colored. If the "40 %" field is also colored, the drying medium must be replaced immediately.

Fig. 2: Humidity indicator on the air-drying unit.

The inspection periods given are only a rough recommendation. They depend heavily on the local conditions at the measurement station and should be adapted in the light of individual experience!

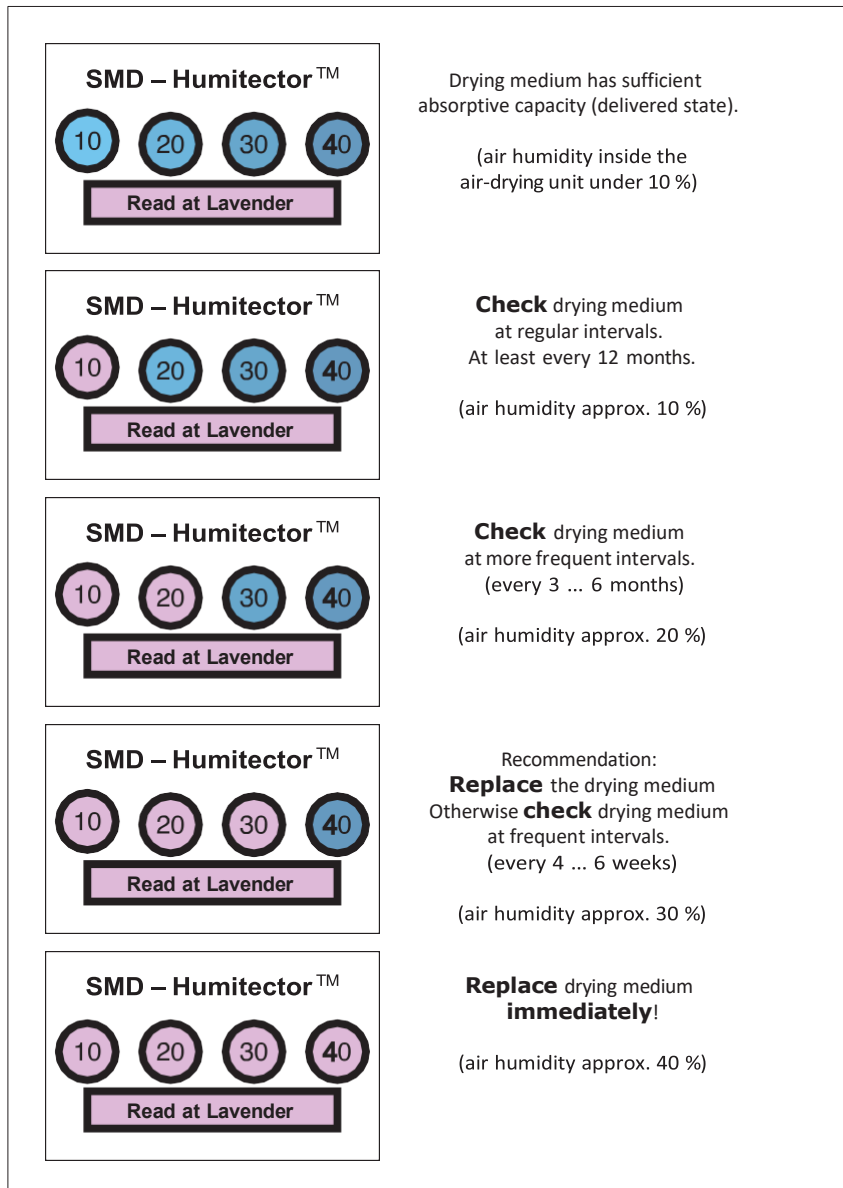



Safety instructions

Caution: Avoid the drying medium contacting the skin or eyes during replacement!
Do not breathe in any dust that occurs!
The drying medium can cause irritation of the skin, eyes and mucous membranes.

Safety recommendation: wear suitable goggles and protective gloves!

If required, we can provide a safety data sheet for the drying medium used (alkali alumino silicate).

How to replace the drying medium:

- Separate the Ott CBS 500 from the electrical supply (pull out screw terminal strip).
- Remove the aluminum bracket for the air-drying unit from the fastening screws.
- Unscrew the red screw cap.
- Pour out the used drying medium. The drying medium can be disposed of in normal household waste.
- Cut off the corner of the drying medium refill pack and pour the drying medium into the air-drying unit up to approx. 1 cm under the filling opening.
- Replace the screw cap immediately and tighten lightly by hand.
- Hang the air-drying unit on the fastening screws again.
- Reconnect electrical supply.

Note: The air humidity indicator regenerates within about 60 minutes after replacing the drying medium (all color fields colored blue again).

6 Technical data

Weight	approx. 1.2 kg
Housing material	Plastic
Protection class	IP 43
Mounting bracket	Aluminum
Drying medium	Molecular sieve (alkali aluminosilicate)
Connection tube length	2 m
Dimensions	See figure

Fig. 3: Dimensions of the Ott CBS 500 air drying unit.

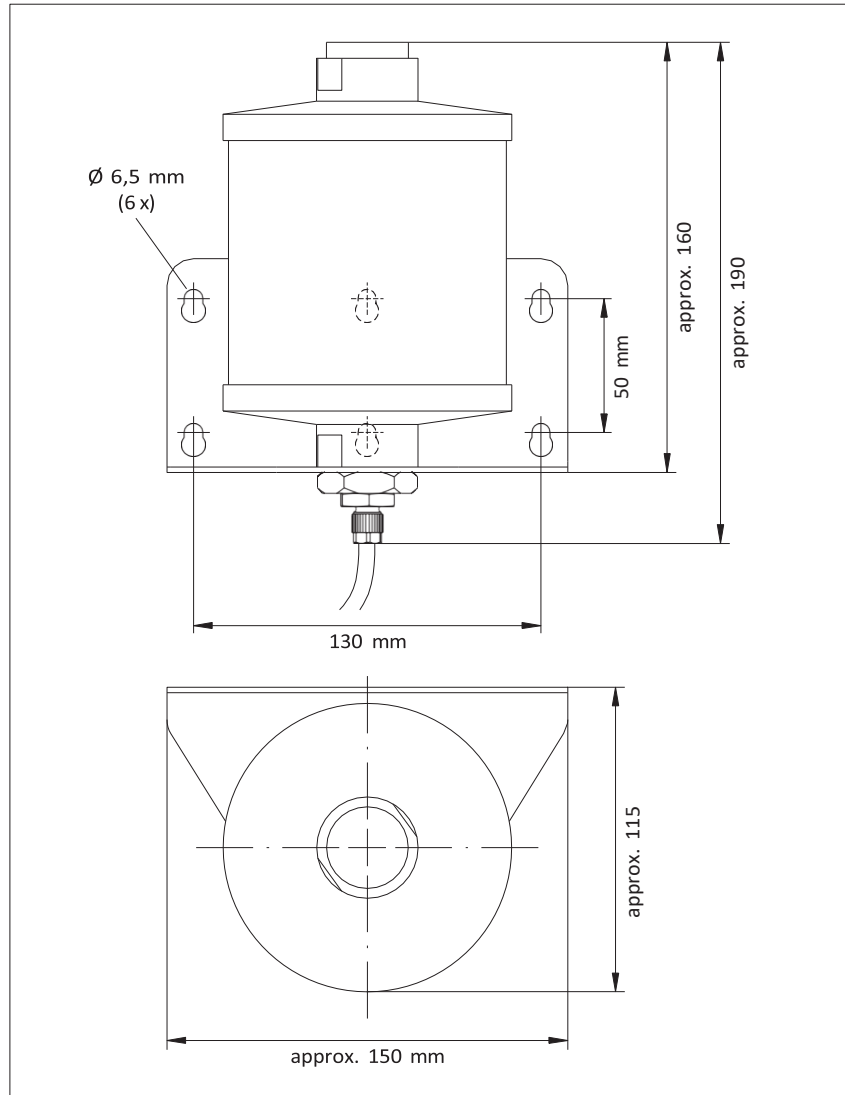

We reserve the right to make technical changes and improvements without notice.

Document number
63.200.030.B.E 02-0626

OTT Hydromet GmbH

Ludwigstrasse 16
87437 Kempten · Germany
Tel. +49 831 5617-0
Fax +49 831 5617-209

info@ott.com · www.ott.com