

Datalogger XLink 2000

Operational Manual

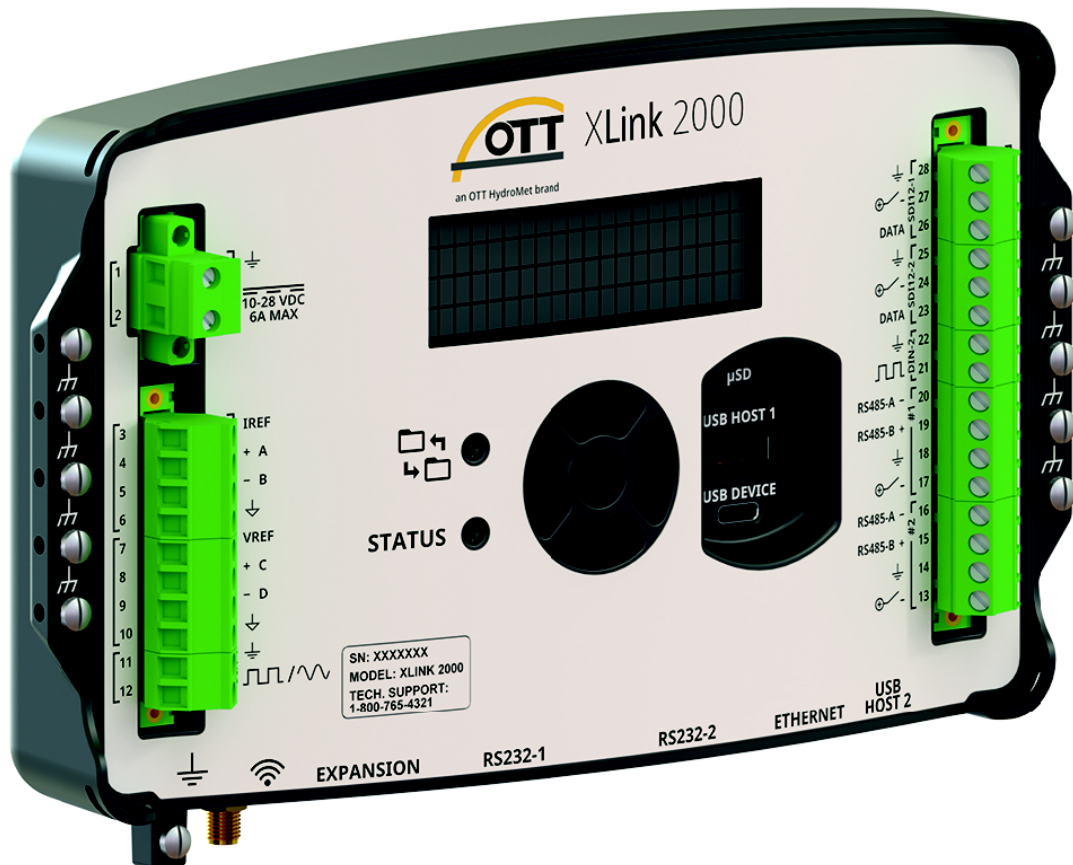

Copyright © OTT HydroMet GmbH

OTT HydroMet GmbH
Ludwigstraße 16
87437 Kempten
Germany

+49 831 5617-0
euinfo@otthydromet.com
www.otthydromet.com

All rights reserved.

All content is the intellectual property of OTT HydroMet. Reprinting, duplication and translation (even as excerpts) are only permitted with the prior written consent of OTT HydroMet.

Subject to technical change.

Table of contents

1	Scope of supply	6
2	Order numbers and variant code	7
2.1	Product variants	7
2.2	Accessories	7
3	About this manual	8
3.1	Other applicable documents and software	8
3.2	General signs and symbols	8
3.3	Explanation of warnings	9
4	General safety instructions	10
4.1	Intended use	10
4.2	Potential misuse	10
4.3	Personnel qualification	10
4.4	Operator obligations	10
4.5	Personnel obligations	10
4.6	Correct handling	10
4.7	Installation and maintenance	11
4.8	Certification	11
4.8.1	CE	11
4.8.2	FCC & ISED	11
5	Product description	13
5.1	Design and function	13
5.2	Product overview	14
5.2.1	Status LEDs	15
5.3	Symbols on the product	15
6	Transport, storage, and unpacking	17
6.1	Transport	17
6.2	Storage	17
6.3	Unpacking	17
7	Installation	18
7.1	Mechanical installation	18
7.1.1	Required tools and aids	18
7.1.2	Requirements of the installation site	18
7.1.3	Installing device	18
7.2	Electrical installation	19
7.2.1	Electrical connections	19

7.2.2	Connecting power supply _____	19
7.2.3	Connecting to earth ground point _____	20
7.2.4	Connecting sensors with resistive load (2-wire) _____	20
7.2.5	Connecting sensors with potentiometer _____	20
7.2.6	Connecting sensors with resistance measuring bridge _____	21
7.2.7	Connecting sensors with resistive load (4-wire) _____	21
7.2.8	Connecting 4 - 20 mA analog sensors _____	22
7.2.9	Connecting sensors with SDI-12 interface _____	22
7.2.10	Connecting sensors with RS-485 interface _____	22
7.2.11	Connecting sensors with RS-485 interface and Modbus _____	23
7.2.12	Connecting sensors with RS-232 interface and Modbus _____	23
7.2.13	Connecting sensors with frequency output _____	23
7.2.14	Connecting sensors with pulse output _____	23
8	Commissioning _____	25
8.1	Downloading and running LinkComm _____	25
8.2	Downloading LinkComm _____	25
8.3	Running LinkComm on Windows _____	25
8.4	Connecting LinkComm to the data logger _____	25
8.5	Working offline _____	26
8.6	Station view _____	27
8.7	Making station-related settings _____	27
8.8	Adding an input device _____	28
8.9	Configuring an input device _____	28
9	Operation _____	30
9.1	Operating XLink with LinkComm _____	30
9.1.1	Setting date and time _____	30
9.1.2	Activating connections for external removable storage media _____	31
9.1.3	Activating protection against unauthorized operation _____	31
9.1.4	Creating and managing users _____	32
9.1.5	Creating and managing actions _____	33
9.1.6	Setting up notification functions _____	34
9.1.7	Configuring serial interfaces for Modbus protocol _____	35
9.1.8	Downloading, displaying and saving data _____	36
9.1.9	Using service and main menu functions _____	38
9.2	Setting up remote data transmission _____	39
9.2.1	Configuring communication devices _____	40
9.2.2	Configuring a network server _____	41
9.2.3	Configuring a telemetry schedule _____	41
9.3	Operating XLink on site with LCD display and navigation pad _____	43
9.3.1	Entering pin _____	43
9.3.2	Viewing station information _____	44
9.3.3	Examining measurements _____	44
9.3.4	Taking measurements _____	44
9.3.5	Entering control values _____	45
9.3.6	Scaling measurements _____	46

9.3.7	Connecting external removable storage media _____	47
9.3.8	Configuring Wi-Fi connection _____	47
9.3.9	Resetting to factory settings _____	48
10	Maintenance _____	49
10.1	Maintenance schedule _____	49
10.2	Updating firmware _____	49
11	Troubleshooting _____	50
11.1	Error elimination _____	50
12	Repair _____	52
12.1	Customer support _____	52
13	Notes on disposing of old devices _____	53
13.1	Disposing integrated lithium coin cell _____	53
14	Technical data _____	54
14.1	Dimensions and weight _____	54
14.2	Electrical data _____	54

1 Scope of supply

The following items are included with delivery:

- Data logger
- Wi-Fi antenna (RP-SMA connector)
- information sheet
- Factory acceptance test certificate

2 Order numbers and variant code

2.1 Product variants

Order number	Description
XLink2000-CA-0-0	XLink 2000-Canada Region
XLink2000-CA-M-0	XLink 2000-Canada Region, with DIN rail
XLink2000-EU-0-0	XLink 2000-EU Region
XLink2000-EU-M-0	XLink 2000-EU Region, with DIN rail
XLink2000-US-0-0	XLink 2000-US Region
XLink2000-US-M-0	XLink 2000-US Region, with DIN rail

2.2 Accessories

Order number	Description
6161-1000	MULTITECH RS-232 cell modem, 2G/3G/4G LTE FDD, Global (EU, US, Canada)

3 About this manual

3.1 Other applicable documents and software

The following documents contain further information on installation, maintenance and calibration:

- Operating instructions of sensors

The following documents and software can be downloaded at www.otthydromet.com:

- LinkComm (from V 1.00.0)
- Firmware (from V 4.1.0)

The following App can be downloaded from iTunes or Google Playstore:

- Link Comm for mobile devices for iOS or Android

3.2 General signs and symbols

The signs and symbols used in the operational manual have the following meaning:

Practical tip



This symbol indicates important and useful information.

Action

- ✓ Prerequisite that must be met before performing an action.
 - ▶ Step 1
 - ⇒ Intermediate result of an action
 - ▶ Step 2
 - ⇒ Result of a completed action

List

- List item, 1st level
 - List item, 2nd level

3.3 Explanation of warnings

To avoid personal injury and material damage, you must observe the safety information and warnings in this manual. The warnings use the following danger levels:

WARNING

WARNING

This indicates a potentially hazardous situation. If the hazardous situation is not avoided, it may result in death or serious injuries.

CAUTION

CAUTION

This indicates a potentially hazardous situation. If the hazardous situation is not avoided, it may result in moderately serious or minor injuries.

NOTICE

NOTE

This indicates a situation from which damage may arise. If the situation is not avoided, products may be damaged.

4 General safety instructions

4.1 Intended use

The data controller is used to measure, log, calculate and transmit data in hydrometry, meteorology and environmental monitoring.

The intended use of the data logger is the cyclical determination, processing and storage of environmental parameters and the transmission of this data via various communication channels.

4.2 Potential misuse

Any use of the product that does not comply with the intended use, be this intentional or negligent, is forbidden by the manufacturer.

- ▶ Use the product only as described in the operational manual.

4.3 Personnel qualification

The equipment described in this manual must be installed, operated, maintained and repaired by qualified personnel only.

- ▶ Obtain training from OTT HydroMet if necessary.

4.4 Operator obligations

The installer is responsible for observing the safety regulations. Unqualified personnel working on the product can cause risks that could lead to serious injury.

- ▶ Have all activities carried out by qualified personnel.
- ▶ Ensure that everybody who works on or with the product has read and understood the operational manual.
- ▶ Ensure that safety information is observed.
- ▶ File the operational manual together with the documentation of the entire system and ensure that it is accessible at all times.

4.5 Personnel obligations

To avoid equipment damage and injury when handling the product, personnel are obliged to the following:

- ▶ Read the operational manual carefully before using the product for the first time.
- ▶ Pay attention to all safety information and warnings.
- ▶ If you do not understand the information and procedure explanations in this manual, stop the action and contact the service provider for assistance.
- ▶ Wear the necessary personal protective equipment.

4.6 Correct handling

If the product is not installed, used and maintained correctly, there is a risk of injury. The manufacturer does not accept any liability for personal injury or material damage resulting from incorrect handling.

- ▶ Install and operate the product under the technical conditions described in the operational manual.
- ▶ Do not change or convert the product in any way.
- ▶ Do not perform any repairs yourself.
- ▶ Get OTT HydroMet to examine and repair any defects.
- ▶ Ensure that the product is correctly disposed of. Do not dispose of it in household waste.

4.7 Installation and maintenance

Opening of the device can cause damage to the device.

- ▶ Never open the data logger.
- ▶ All sensors, communication devices, power supply, contacts and additional components are connected via plug-in screw terminal strips and plug connectors on the outside of the device.

4.8 Certification

4.8.1 CE

The equipment meets the essential requirements of RED 2014/53/EU.

4.8.2 FCC & ISED

The OTT Hydromet Corp. XLink 2000 complies with the limits for a Class B digital device under FCC Part 15 of the FCC Rules and Regulations and Telecommunications Policy ICES-003 Issue 7 of Innovation, Science and Economic Development (ISED) Canada.

Model	Description
XLink2000-EU-...	The equipment meets the essential requirements of EMC Directive 2014/30/EU and RED 2014/53/EU
XLink2000-US-...	Contains FCC ID: SQG-LWB5PLUS
XLink2000-CA-...	Contains IC ID: 3147A-LWB5PLUS

Unintentional radiator

FCC (US)

FCC Part 15, Class "B" Limits

This device complies with part 15 of the FCC Rules. Operation is subject to the following two conditions:

1. This device may not cause harmful interference.
2. This device must accept any interference received, including interference that may cause undesired operation.

Changes or modifications to this equipment not expressly approved by the party responsible for compliance could void the user's authority to operate the equipment.

IC (CA)

Canadian Radio Interference-Causing Equipment Regulation, ICES-003, "Class B"

This Class B digital apparatus meets all requirements of the Canadian Interference-Causing Equipment Regulations.

Intentional radiator WIFI-module

FCC (US)

FCC Part 15C Statement intentional radiator

This device complies with part 15 of the FCC Rules. Operation is subject to the following two conditions:

1. This device may not cause harmful interference.
2. This device must accept any interference received, including interference that may cause undesired operation.

i Unauthorized modification or changes to this wireless communication equipment will void the right to use it. Changes or modifications to this unit not expressly approved by the party responsible for compliance will void the user's authority to operate the equipment. Any change to the equipment will void the FCC grant.

Contains FCC ID: SQG-LWB5PLUS

IC (CA)

Canadian Radio Interference-Causing Equipment Regulation, ICES-001

This device complies with Industry Canada license-exempt RSS standard(s). Operation is subject to the following two conditions:

1. This device may not cause harmful interference.
2. This device must accept any interference, including interference that may cause undesired operation of the device.

Contains IC ID: 3147A-LWB5PLUS

Intentional radiator Cellular-module

FCC (US)

FCC Part 15C Statement intentional radiator

This device complies with part 15 of the FCC Rules. Operation is subject to the following two conditions:

1. This device may not cause harmful interference.
2. This device must accept any interference received, including interference that may cause undesired operation.

i Unauthorized modification or changes to this wireless communication equipment will void the right to use it. Changes or modifications to this unit not expressly approved by the party responsible for compliance will void the user's authority to operate the equipment. Any change to the equipment will void the FCC grant.

Contains FCC ID: RI7LE910CXWWX

IC (CA)

Canadian Radio Interference-Causing Equipment Regulation, ICES-001

This device complies with Industry Canada license-exempt RSS standard(s). Operation is subject to the following two conditions:

1. This device may not cause harmful interference.
2. This device must accept any interference, including interference that may cause undesired operation of the device.

Contains IC ID: 5131A-LE910CXWWX

5 Product description

5.1 Design and function

The XLink 2000 is an IP-capable (Internet Protocol) data logger.

The device has been designed for hydrometry, meteorology, and environmental monitoring, and provides the following functions:

- Make measurements from sensors monitoring the environment.
- Perform special calculations.
- Record data into non-volatile memory.
- Transmit data to automated receiving systems.

The data logger is equipped with the following input channels: two RS-485 interfaces, two SDI-12 interfaces, two pulse/status inputs, two RS-232 interfaces, four analog interfaces. The device has a switched power output and reference voltage outputs. There are three USB host/device ports, a microSD slot and an Ethernet interface (RJ-45). For operation on site, the device has an LCD display and navigation pad.

The low power consumption of the data logger allows for reliable operation via a solar panel system.

In combination with an external cell modem, both remote data transmission and remote parameterization via the cellular network and LAN are possible.

Local communication with the device can take place either via a USB cable connection or via Wi-Fi.

5.2 Product overview

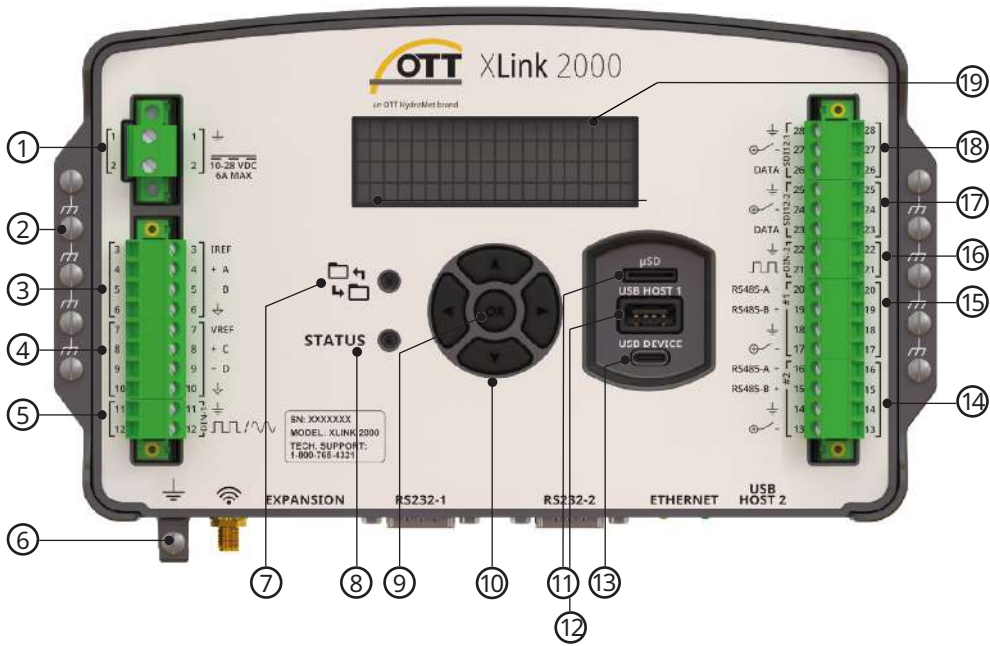

XLink 2000 connections and buttons on the front of the device

- | | | | |
|----|--|----|---------------------------------------|
| 1 | Power or battery | 11 | Micro SD slot |
| 2 | Connection braided shield (optional) | 12 | USB-A host 1 |
| 3 | Analog outputs A/B | 13 | USB-C device |
| 4 | Analog outputs C/D | 14 | RS-485 interface 2 |
| 5 | Pulse/frequency input | 15 | RS-485 interface 1 |
| 6 | Earth ground | 16 | Pulse input 2 |
| 7 | LED Wi-Fi hotspot | 17 | SDI-12 interface 2 |
| 8 | LED <i>STATUS</i> | 18 | SDI-12 interface 1 |
| 9 | Navigation pad confirmation button <i>OK</i> | 19 | LCD display (4 lines x 20 characters) |
| 10 | Navigation pad direction buttons | | |

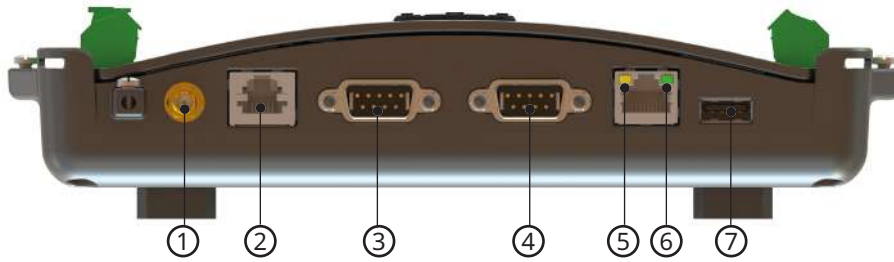

XLink 2000 connections on the underside of the device

- | | | | |
|---|--------------------|---|--------------------------|
| 1 | Wi-Fi antenna | 5 | Ethernet Interface LED A |
| 2 | Extension bus | 6 | Ethernet Interface LED B |
| 3 | RS-232 Interface 1 | 7 | USB-A host 2 |
| 4 | RS-232 Interface 2 | | |







5.2.1 Status LEDs

The status LEDs give information on how the device is operating. There are two multi-colored LEDs on the front of the device, and a yellow and green LED on the Ethernet interface. The following table describes the different colors and states of the LEDs.

Status	LED on device	LED Status on device	LED A (Link Status)	LED B (Traffic)
Device is ready for operation	–	Green light continuously	–	–
Device has an operating error	–	Red light continuously	–	–
Deactivated Wi-Fi connection	LED is off	–	–	–
Active Wi-Fi connection	Blue blink every second (1 Hz)	–	–	–
Active connection (link) to network component	–	–	Yellow light continuously	–
Transmitting and receiving activity via the Ethernet interface	–	–	–	Green flash
Ethernet interface deactivated or incorrectly configured	–	–	LED permanently off	LED permanently off

5.3 Symbols on the product

Symbol	Meaning
	Direct current

Symbol	Meaning
	Protective earth ground Connection to an earth ground electrode for lightning protection of internal components
	Digital ground Connection to the digital sensor ground, negative terminals of the batteries and the solar panel
	Signal ground Connection to analog sensor ground
	Chassis ground
	With this symbol, the manufacturer declares the conformity of the product with the applicable EU directives.
	Do not dispose of in the trash.
	

6 Transport, storage, and unpacking

6.1 Transport

- ▶ Transport the product always in its original packaging.
- ▶ Ensure that the product is not mechanically stressed during transport.

6.2 Storage

- ▶ Store within specified temperature ranges.
- ▶ Store in dry area.
- ▶ Store in original box where possible.

6.3 Unpacking

- ▶ Carefully remove the product from the packaging.
- ▶ Check that the delivery is complete and undamaged.
- ▶ If you find any damage or if the delivery is incomplete, then immediately contact your supplier or manufacturer.
- ▶ Keep the original packaging for any further transportation.

7 Installation

7.1 Mechanical installation

7.1.1 Required tools and aids

The following tools and aids are required:

- small flathead screwdriver

7.1.2 Requirements of the installation site

The following requirements apply to the installation site:

- Sufficient protection from moisture for an IP 40 device
- Protection from direct sunlight
- Proper space for the electrical cables and optional Wi-Fi antenna
- Temperature range -40 °C to +70 °C

7.1.3 Installing device



Risk of explosion due to sparking and electrostatic charge!

When operating the device in an explosive atmosphere, there is a risk of ignition of this atmosphere. An explosion caused by this carries the risk of serious damage to property and personal injury.

- ▶ Never operate the device in potentially explosive atmospheres (e.g. in sewers). The device has no EX protection (explosion protection)!

It is recommended to mount the device inside a ventilated and lockable metal switch cabinet or on a suitable, weather-protected surface.

- The range of the integrated Wi-Fi hotspot outdoors is max. 100 m (without physical barriers between transmitter and receiver), indoors max. 25 m. If the data logger is installed in a closed metal control cabinet, the cabinet's door must be open to ensure a stable wireless connection.

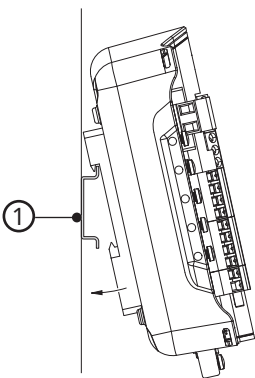

1 DIN rail

- ✓ The DIN rail (min. length 17 cm) is pre-assembled at the installation site.
- ▶ Install the device on the DIN rail.
- ▶ Hook the DIN rail adapter into the DIN rail on the back of the housing.

- ▶ Press the bottom of the housing against the DIN rail until the DIN rail adapter audibly clicks into place.

If in case the device must be removed again:

- ▶ Power down the device.
- ▶ Unplug all wiring connectors.
- ▶ Identify the spring-loaded tab or clip on the bottom of the data logger.
- ▶ Insert a flathead screwdriver into the eyelet or slot of the locking tab.
- ▶ Push the clip down to disengage it from the DIN rail.
- ▶ Pivot the bottom of the data logger away from the rail and lift it up to remove it completely.

7.2 Electrical installation

7.2.1 Electrical connections

All ground and equipotential connection pins are connected internally inside the device.

Switched supply voltage is applied to the connection pins 13, 17, 24 and 28 (10 - 28 V DC).

All screw terminal strips are pluggable. If necessary, they can be removed for installation.

Both fine-wired (flexible) and single-wired (rigid) electrical conductors can be connected to the screw terminal strips. It is recommended to use wire end ferrules for fine-wired conductors.

For specific values, see Electrical data [▶ 54].

- ▶ Route the connection cables, so that there are not subject to any mechanical load (e.g. in a cable conduit).
- ▶ If necessary, use a suitable strain relief (e.g. fix the conductor to one of the device corners using a cable tie).

7.2.2 Connecting power supply

- ▶ Connect the battery or power source (10 - 28 V DC) to the device across the terminals 1 and 2. The battery cable must have an inline fast fuse to handle current up to 6.3 A.



- ▶ Keep the cable length as short as possible, see Electrical data [▶ 54].
- ▶ Ensure that the power supply is properly rated.
- ▶ Ensure that all wires are properly attached to the terminal strips.
- ▶ Only use an electrically isolated safety extra-low voltage for a power supply from the public power grid.
- ▶ Always provide strain relief for the conductors for the power supply (e. g. fix the conductor to one of the corners of the appliance with cable ties).

7.2.3 Connecting to earth ground point

NOTICE

Damage due to surges!

If the earth ground point is not connected properly, this may result in surges that can damage the device.

- ▶ Connect the earth ground point to a suitable ground at the site.
 - ▶ Do not rely on AC power ground connections as they are not always properly grounded.
-
- ▶ Use a yellow/green grounding cable.
 - ▶ Connect the grounding cable to the earth ground point of the device.
 - ▶ Connect the grounding cable to the equipotential bonding bar, a foundation grounding or rod grounding.

7.2.4 Connecting sensors with resistive load (2-wire)

Sensors with resistive load (2-wire) can connect as shown below.

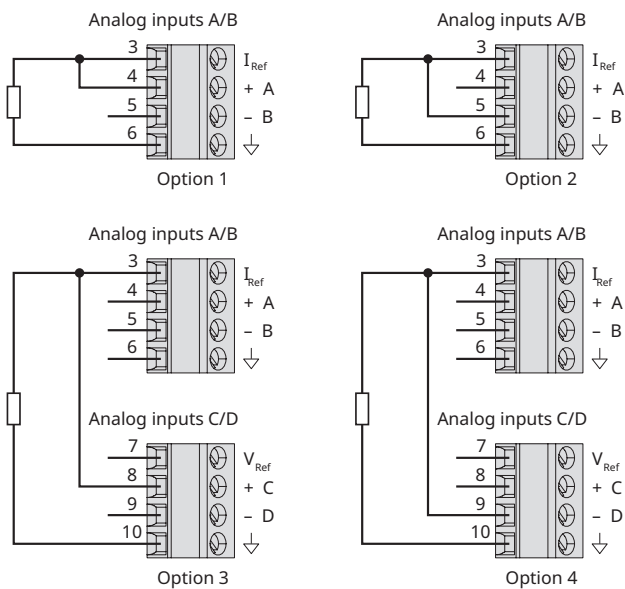

i For more information on sensor installation, refer to the operating instructions of the respective sensor.

7.2.5 Connecting sensors with potentiometer

Sensors with potentiometer can connect as shown below.

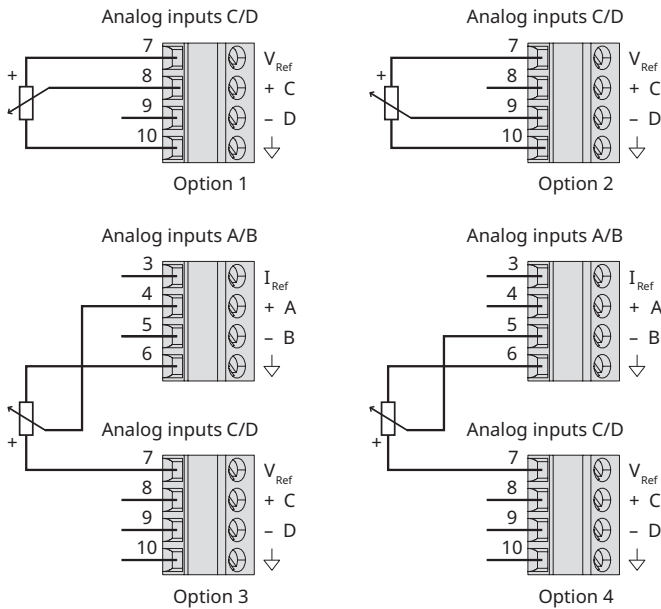

i For more information on sensor installation, refer to the operating instructions of the respective sensor.

7.2.6 Connecting sensors with resistance measuring bridge

Sensors with resistance measuring bridge can connect as shown below.

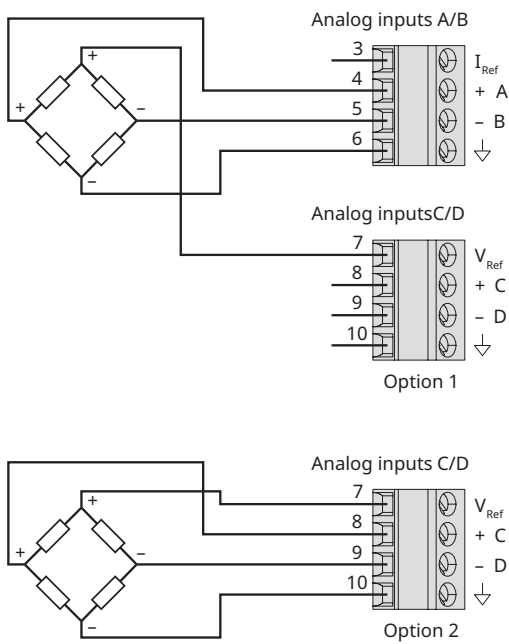

i For more information on sensor installation, refer to the operating instructions of the respective sensor.

7.2.7 Connecting sensors with resistive load (4-wire)

Sensors with resistive load (4-wire) can connect as shown below.

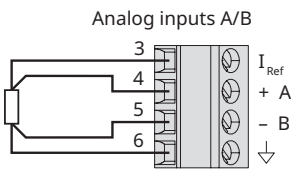

i For more information on sensor installation, refer to the operating instructions of the respective sensor.

7.2.8 Connecting 4 - 20 mA analog sensors

One sensor can connect directly to the 4 – 20 mA input as shown below. The other sensor can connect either to connection 13 or 17.

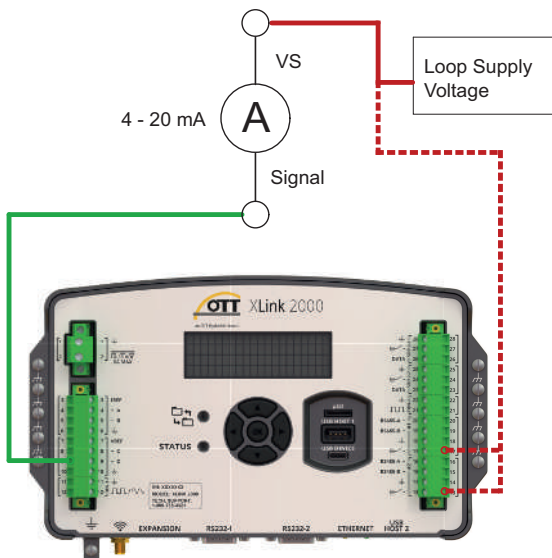

Connecting analog sensors

i For more information on sensor installation, refer to the operating instructions of the respective sensor.

7.2.9 Connecting sensors with SDI-12 interface

Sensors with SDI-12 interface can connect as shown below.

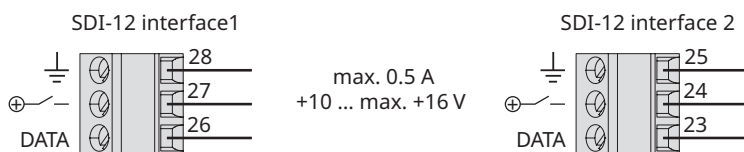

i For more information on sensor installation, refer to the operating instructions of the respective sensor.

7.2.10 Connecting sensors with RS-485 interface

Sensors with RS-485 interface can connect as shown below. The connections 13, 14, 17 and 18 are only required if the sensor is supplied with power by the device.

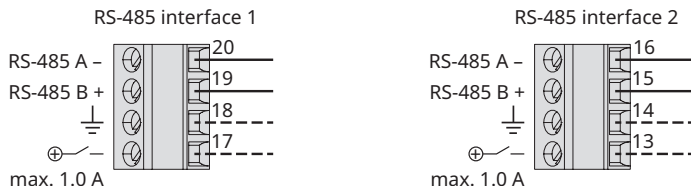

i For more information on sensor installation, refer to the operating instructions of the respective sensor.

7.2.11 Connecting sensors with RS-485 interface and Modbus

Sensors with RS-485 interface and Modbus can connect as shown below.

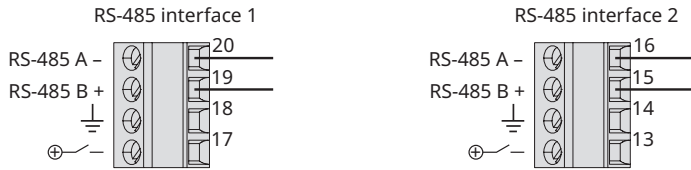

i For more information on sensor installation, refer to the operating instructions of the respective sensor.

7.2.12 Connecting sensors with RS-232 interface and Modbus

Sensors with RS-232 interface and Modbus can connect as shown below.

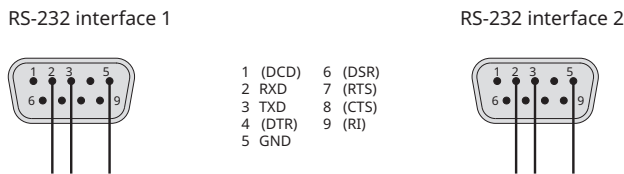

i For more information on sensor installation, refer to the operating instructions of the respective sensor.

7.2.13 Connecting sensors with frequency output

Sensors with frequency input can connect as shown below.

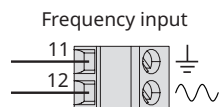

i For more information on sensor installation, refer to the operating instructions of the respective sensor.

7.2.14 Connecting sensors with pulse output

Sensors with pulse output can connect as shown below.



i For more information on sensor installation, refer to the operating instructions of the respective sensor.

8 Commissioning

8.1 Downloading and running LinkComm

LinkComm is an application used to view status and configure OTT HydroMet data loggers.

LinkComm is used to:

- Check status and measurement data
- Set up configuration
- Download the log and graph the data
- Perform diagnostics (e.g. send a command, set the time)
- Upgrade the firmware

8.2 Downloading LinkComm

LinkComm can be installed on PC and MAC. Mobile versions are available in the respective app stores.

Install LinkComm on PC or MAC as follows:

- ▶ Download the required version of LinkComm: www.otthydromet.com/en/software_firmware
- ▶ Unzip LinkComm to its own folder.
- ▶ Run *LinkComm.exe*.

Install the mobile version as follows:

- ▶ Open the Apple App Store or Google Play Store.
- ▶ Search on LinkComm.
- ▶ Select *Install*.

8.3 Running LinkComm on Windows

LinkComm may be run directly from the unzipped folder.

- ▶ To run LinkComm, select *LinkComm.exe*.

8.4 Connecting LinkComm to the data logger

Communication between the data logger and a PC or mobile device takes place optionally via:

- a USB-C cable connection (on site)
- a Wi-Fi connection (on site)
- a LAN connection (on site or via remote access)

i The range of the integrated Wi-Fi hotspot outdoors is max. 100 m (without physical barriers between transmitter and receiver), indoors max. 25 m. If the data logger is installed in a closed metal control cabinet, the cabinet's door must be open to ensure a stable wireless connection.

- ▶ Start LinkComm.
 - ⇒ When LinkComm is opened for the first time, the stations list view appears and New Station is selected by default.
- ▶ Specify the *Station type* "OTT XLink 2000".

- ▶ Select the **New Station** button.
- ▶ Select connection type *USB*.
- ▶ Connect the PC to the data logger via the USB-C cable.
- ▶ If there are entries in the fields *User Name* and *Password*, delete these entries.
- ▶ Select the **Connect** button.
 - ⇒ The software establishes a connection to the data logger and opens a window for entering the serial number of the device.
- ▶ Enter the serial number (see type plate of the device) and click **Send**.
 - ⇒ A window opens for assigning user name and password.
- ▶ Enter the desired user name and password.
- ▶ Enter the password a second time to confirm.
- ▶ Click the **Add User** button.
 - ⇒ The operating software creates a new, initial user with Administrator access authorization and reads the factory configuration.
 - ⇒ The software opens the overview window *Dashboard*.

When LinkComm is connected again (standard), proceed with the following steps:

- ▶ Click the **New Station** button.
 - ⇒ Alternatively, if the desired data logger is already saved in the list of stations (via the main menu, *Save Station ...*):
- ▶ Then click on the button of the saved data logger.
- ▶ Select the desired *Connect Type*:

Parameter	Description
WLAN of Station	Connect the PC to the Wi-Fi of the OTT XLink 2000.
TCP/IP	Enter either the IP address or the name of the host. The required TCP port is "22".
USB	Connect the PC to the OTT XLink 2000 via the USB-C cable.

- ✓ The user must be created with required rights, see chapter Creating and managing users [▶ 32].
- ▶ Enter the user name and corresponding password (click on the eye symbol behind the input field to display the password).
- ▶ If required, activate the checkbox *Get recent data on connect* (the last measured values of the last seven days).
- ▶ Select the **Connect** button.
 - ⇒ The software establishes a connection to the data logger and reads the current configuration and last measured values.
 - ⇒ The software opens the overview window *Dashboard*.

8.5 Working offline

When choosing the **Work Offline** button in the stations list view, instead of the **Connect** button, LinkComm enters offline mode. In this mode, LinkComm does not try to communicate with the device over the network. This mode is useful for making changes to setups that are later loaded into a station.

-  Changes made in offline mode are not saved in the data logger.

8.6 Station view

After LinkComm is connected to a station, the station view appears.

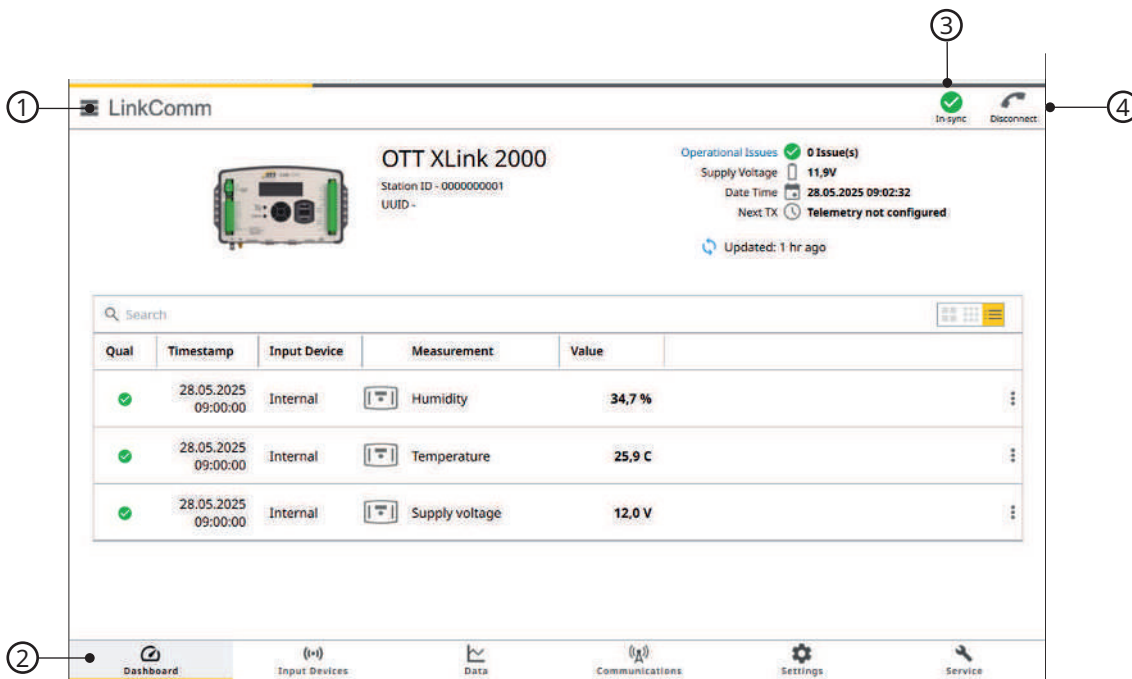

Dashboard of LinkComm for XLink2000 factory configuration (with internal sensors, without external sensors)

- | | | | |
|---|-----------|---|-----------------------------|
| 1 | Main menu | 3 | Setup status button |
| 2 | Tabs | 4 | Disconnect / Connect button |

8.7 Making station-related settings

The *System Properties* tab can be used to make changes to the station-related settings.

- ▶ Select the **Settings** button.
- ▶ Select the *System Properties* tab.
- ▶ Make settings for the station:

Parameter	Description
Station name	Station name; max. 40 characters (alphanumeric). Default setting: "Xlink 2000"
Station ID	Station ID; max. 10 characters (alphanumeric). Default setting: "0000000001"
UUID	Universally Unique Identifier; optional; enables a unique identifier to be added to the station; max. 64 characters (alphanumeric). In connection with the file format "ZRXP", this field is used to enter the "REX-CHANGE" number (software "WISKI" of company Kisters).
Local time offset	Time difference between the station and Coordinated Universal Time (UTC)

- ▶ Optionally, set the location via the *Station Location* tab.
- ▶ Save the station information via the main menu, *Save Station ...* .

8.8 Adding an input device

Sensors and cameras connected to the data logger must be added as an input device in the configuration.

 Input devices can be displayed in the software in two different views - as a list or in tile form.

- ▶ Click on the **Input Devices** button.
 - ⇒ A window opens with an overview of all existing input devices.
- ▶ Click on **Add device** and select the type of new input device from the list that appears.
 - ⇒ A window for detailed selection of input devices opens.
- ▶ Select the specific model of the input device.

The operating software offers a variety of standard configurations for input devices from different manufacturers. To make the search easier, the selection can be narrowed down to a specific manufacturer. If a desired device is not available, the *Generic sensor ...* variant can be used as an alternative.

- ▶ Click on the **Select** button.
 - ⇒ The software adds a new entry to the overview of input devices.

8.9 Configuring an input device

 For the configuration of the input device, refer to the operating instructions of the corresponding sensor.

The following procedure serves as an example and is based on a sensor with an SDI-12 interface. With minor adjustments, it also applies to other sensor types.

- ▶ Select the new input device in the list.
- ▶ Alternatively, click on  and select **Settings**
 - ⇒ A window for configuring the input device opens.
- ▶ For general settings for this sensor select *Power Settings*.
 - ⇒ If required: connection of the supply voltage can be entered.
- ▶ Enter the required preheating time of the sensor.
- ▶ Go to the section *SDI-12 Configuration* for SDI-12 settings.
 - ⇒ A menu will show-up, where address and interface can be entered.
- ▶ If necessary, send SDI-commands to the sensor using the **SDI-12 Test**, **SDI-12 Extended** and **Change Address** buttons.
- ▶ Go to *Measurement Configuration 1* for common settings for all measured values of this sensor.
 - ⇒ Polling interval, time offset of the first polling interval to 0 o'clock and SDI-12 command used for measurement can be entered.
 - ⇒ If required, the **Measure** button starts an instantaneous value measurement.
- ▶ If no preconfigured measurement is available for this sensor, click on **Add Measurement**.
 - ⇒ The operating software creates a new measurement.
- ▶ Click on the desired measured value in the list of measurements.
 - ⇒ A window for configuring this measured value opens.
- ▶ Select the *Settings* tab.

- ▶ Make settings for this measured value (SDI-12 parameter of this measured value, number of decimal places, unit, output value when an error occurs).
- ▶ Add further measurement configuration for this sensor if required: click on **Add Measurement**.

If required, an input device can be deleted:

- ▶ In the list, select the input device and click on **Delete**.
- ▶ Confirm the security prompt with **Delete**.

9 Operation

9.1 Operating XLink with LinkComm

The following sections describe how to perform some common functions with an XLink station. This requires that the station is powered on, LinkComm is running, and there is a connection to the station via USB, RS-232, or Wi-Fi.

Setting date and time is required for commissioning. The further sections are optional settings for commissioning.

 An overview of the LinkComm interface can be found in the section Station view [▶ 27].

9.1.1 Setting date and time

 The internal clock of the data logger is a real-time clock with high accuracy. It runs from the time of production of the device. In the event of an interruption in the supply voltage, a built-in lithium button cell takes over the power supply to the real-time clock. The date and time are set using LinkComm.

In addition, the data logger can use the "SNTP Time Sync" function to automatically synchronize the date and time via a connected cell modem with Internet access. In this case, it uses the so-called Coordinated Universal Time (UTC), whereby the local time of the measuring point is adjusted via a set local time offset. The automatic time synchronization checks the date and time once a day and corrects the values if necessary.

To configure automatic time synchronization or set the date and time manually, proceed with the following steps:

- ▶ Start LinkComm.
- ▶ Establish a connection to the data logger, see chapter Connecting LinkComm to the data logger [▶ 25].
- ▶ Click on the **Settings** button.
- ▶ Select the *System Properties* tab.

Configure automatic time synchronization (optional):

- ✓ A cell modem is connected and the required modem settings have been made, see chapter Configuring communication devices [▶ 40].
- ▶ Activate the "SNTP Time Sync" switch and enter at least one address of a server for time synchronization, e.g. "0.europe.pool.ntp.org".
- ▶ Select the local time offset of the measuring point in relation to Coordinated Universal Time.
- ▶ Click on the yellow warning triangle.
 - ⇒ A window for sending the configuration to the data logger opens. (The yellow warning triangle indicates that the configuration within the software has changed.)
- ▶ Click on the **Send Configuration to Station** button.
 - ⇒ The software sends the changed configuration to the data logger.

Set date and time manually

- ▶ Click on the **Set Clock ...** button.
- ▶ Set date and time manually or activate the checkbox *Set Clock Based on PC Time*.

- ▶ Click on the **Set Clock ...** button.
 - ⇒ The software sets date and time of the data logger according to the PC date and time or the manually set values.
- ▶ Click on the **Close ...** button.

9.1.2 Activating connections for external removable storage media

The data logger has three interfaces for connecting external removable storage media: a card slot for a microSD card and two USB host interfaces (USB-A sockets) for inserting USB sticks. If a microSD card or USB stick is inserted, the connection provided for this purpose must be activated, before the storage media can be used.

To activate connections for external removable storage media, proceed with the following steps:

- ▶ Start LinkComm.
- ▶ Establish a connection to the data logger, see chapter Connecting LinkComm to the data logger [▶ 25].
- ▶ Click on the **Settings** button.
- ▶ Select the *System Properties* tab.
- ▶ Activate the switch for the required connections in the *Removable Storage* section.
- ▶ Click on the yellow warning triangle.
 - ⇒ A window for sending the configuration to the data logger opens. (The yellow warning triangle indicates that the configuration within the operating software has changed.)
- ▶ Click on the **Send Configuration to Station** button.
 - ⇒ The software sends the changed configuration to the data logger.
- ▶ If required, click on the **Browse SD Card/USB Host...** button to view the contents of the storage medium.

9.1.3 Activating protection against unauthorized operation

To prevent unauthorized access to the data logger on site, the device can be secured with a pin. In this case, the pin must be entered when the navigation pad is operated, see chapter Entering pin [▶ 43].

To activate protection against unauthorized device operation, proceed with the following steps:

- ▶ Start LinkComm.
- ▶ Establish a connection to the data logger, see chapter Connecting LinkComm to the data logger [▶ 25].
- ▶ Click on the **Settings** button.
- ▶ Select the *System Properties* tab.
- ▶ Activate the switch *Activate PIN* in the *Display* section.
- ▶ Enter a PIN of at least six digits in the *PIN* field (digits only).
- ▶ In the *Timeout (s)* input field, enter the desired time period in seconds after which the device should be locked again after the last operating activity.
- ▶ Click on the yellow warning triangle.
 - ⇒ A window for sending the configuration to the data logger opens. (The yellow warning triangle indicates that the configuration within the operating software has changed.)
- ▶ Click on the **Send Configuration to Station** button.
 - ⇒ The software sends the changed configuration to the data logger.

9.1.4 Creating and managing users



When establishing a communication connection between the data logger and a PC or mobile device, a user name and an associated password must be entered. Each user name is automatically assigned a corresponding access authorization. Any number of users can be created and their user data managed via the user administration of the data logger. The *Administrator* access authorization is required for these activities.

An initial user is created, when establishing a connection to the data logger for the first time.

To create and manage additional users, proceed with the following steps:

- ▶ Start LinkComm.
- ▶ Establish a connection to the data logger, see chapter Connecting LinkComm to the data logger [▶ 25].
- ▶ Click on the **Settings** button.
- ▶ Select the *User* tab.
- ▶ To create an additional user, click on **Add User**.
 - ⇒ A window for entering the user data opens.
- ▶ Enter user name and temporary password (for the first login).
- ▶ To confirm, enter the password a second time.
- ▶ Select the desired access authorization for this user:

Parameter	Description
Viewer	No changes possible
Configuration	Device configuration can be changed
Administrator	Unrestricted administrator use

- ▶ Click on the **Add user** button.
 - ⇒ The software creates a new user and enters the new user in the list of users.
- ▶ At first login: change the password for the new user.
- ▶ To change access authorization: click on  and select **Change Access**
 - ⇒ A window for changing the access authorization opens.
- ▶ Select different access authorization.
- ▶ Click on the **Change Access ...** button.
 - ⇒ The device's settings are updated.
- ▶ To change the password: click on  and select **Change Password**
 - ⇒ A window for entering the new password opens.
- ▶ Enter a new password.
- ▶ Click on the **Change Password ...** button.
 - ⇒ The device's settings are updated.

If required, a user can be deleted:

- ▶ Select a user in the list.
- ▶ Click on  and select **Delete**.

- ▶ Confirm the security prompt with **Delete**.

9.1.5 Creating and managing actions

The data logger can automatically execute a previously configured action when certain events occur.

The following actions are available:

- Change the query interval of a measurement (temporarily).
- Temporarily change the transmission interval of a configured data transmission. Three additional, limit-controlled time intervals are available for this purpose.
- Perform an instantaneous value measurement.
- Take a photo or video.
- Change the status of the switched supply voltages (connection pins 13, 17, 24 and 28).
- Send a message (SMS text message, e-mail, alarm message via OTT protocol to the OTT Hydras 3 user software, alarm message to an HTTP/HTTPS/FTP/SMTP server).
- Execute a configured data transmission.

Possible triggering events are:

- System-related processes
- Defined conditions of a measured value (limit value event) or
- Defined conditions of a calculated value (limit value event)

An action is either created as described below or directly in the configuration of an input device. Both variants are linked: an action created under *Input Devices* appears in the list of actions under *Settings* – and vice versa. Conditions that start an action and are based on measured values or calculated values must always be defined under *Input devices*. They are then already predefined and available for the following work steps. Conditions that result from system-related processes must be configured under *Actions*.

To create or change an action, proceed with the following steps:

- ▶ Start LinkComm.
- ▶ Establish a connection to the data logger, see chapter Connecting LinkComm to the data logger [▶ 25].
- ▶ Click on the **Settings** button.
- ▶ Select the *Actions* tab.
- ▶ To create an action, click on **Add Action**.
 - ⇒ The software adds a new entry to the list of actions.
- ▶ Click on the new action in the list.
- ▶ Alternatively, click on  and select **Settings**.
 - ⇒ A window opens to configure the action.
- ▶ Click on **Add Condition** button.
- ▶ Select the type of condition from the following: *System Event*, *Measurement Condition* or *Calculation Condition*.
 - ⇒ The software adds a new condition.
- ▶ Accept predefined condition of an input device or calculation (type: *Measurement Condition* or *Calculation Condition*) or select *Source* (type: *System Event*).
- ▶ If required add further condition(s).

- ▶ Enter a (short) description of the action, select the action type and make the specific settings required.
- ▶ Click on < **Actions** to return to the list of actions.
- ▶ To change an action, click on the action to be changed in the list.
- ▶ Alternatively, click on  and select **Settings**.
- ▶ Change the action, refer to the steps described above.

If required, an action can be deleted:



- ▶ Select an action in the list.
- ▶ Click on  and select **Delete**.
- ▶ Confirm the security prompt with **Delete**.
- ▶ Click on the yellow warning triangle.
 - ⇒ A window for sending the configuration to the data logger opens. (The yellow warning triangle indicates that the configuration within the operating software has changed.)
- ▶ Click on the **Send Configuration to Station** button.
 - ⇒ The software sends the changed configuration to the data logger.



9.1.6 Setting up notification functions

To enable the data logger to send a message within an action, a notification path must be configured and a recipient for the message must be created, see previous chapter *Creating and managing actions* [▶ 33].

In so-called recipient groups, a message can be sent to several recipients at the same time if required.

To create or change a recipient, recipient group or notification path, proceed with the following steps:

- ▶ Start LinkComm.
- ▶ Establish a connection to the data logger, see chapter *Connecting LinkComm to the data logger* [▶ 25].
- ▶ Click on the **Communications** button.
- ▶ Select the *Notifications* tab.
- ▶ To create notifications, click on the **Add Notification Group** button.
 - ⇒ The software adds a new entry to the list of notification paths.
- ▶ Click on the new notification group in the list.
- ▶ Alternatively, click on  and select **Settings**.
 - ⇒ A window opens to configure the notification group.
- ▶ Enter the name of the notification group.
- ▶ To create destinations, click on the **Add Destination** button.
- ▶ Click on the **Create new destination** button.
 - ⇒ The software adds a new entry to the list of destinations.
- ▶ Click on the new destination in the list.
- ▶ Alternatively, click on  and select **Settings**.
 - ⇒ A window opens to configure the destination.
- ▶ Enter the name of the destination, phone number, and/or email and any notes.

- ▶ Click on the yellow warning triangle.
 - ⇒ A window for sending the configuration to the data logger opens. (The yellow warning triangle indicates that the configuration within the operating software has changed.)
- ▶ Click on the **Send Configuration to Station** button.
 - ⇒ The software sends the changed configuration to the data logger.
- ▶ To change notification groups, select the *Destinations* list.
- ▶ Click on the destination to be changed.
- ▶ Alternatively, click on  and select **Settings**.
 - ⇒ A window opens to configure the destination.
- ▶ Toggle on or off **Notification Groups**.
- ▶ To change destinations, select the *Notification Groups* list.
- ▶ Click on the group to be changed.
- ▶ Alternatively, click on  and select **Settings**.
 - ⇒ A window opens to configure the destination.
- ▶ Click on the **Add Destination** button.
- ▶ Click on the **Create new destination** button.
- ▶ Alternatively, click on  to remove a destination.
- ▶ Click on the yellow warning triangle.
 - ⇒ A window for sending the configuration to the data logger opens. (The yellow warning triangle indicates that the configuration within the operating software has changed.)
- ▶ Click on the **Send Configuration to Station** button.
 - ⇒ The software sends the changed configuration to the data logger.

If required, a notification group or destination can be deleted:

- ▶ Select the notification group or destination from the list.
- ▶ Click on  and select **Delete**.
- ▶ Confirm the security prompt with **Delete**.
- ▶ Click on the yellow warning triangle.
 - ⇒ A window for sending the configuration to the data logger opens. (The yellow warning triangle indicates that the configuration within the operating software has changed.)
- ▶ Click on the **Send Configuration to Station** button.
 - ⇒ The software sends the changed configuration to the data logger.

9.1.7 Configuring serial interfaces for Modbus protocol

The data logger enables the connection of devices or sensors with Modbus protocol via the RS-485 and RS-232 serial interfaces. The transmission parameters of the serial interfaces can be configured according to the individual requirements of the connected sensors or devices. This has no effect on other devices connected to the appropriate interface, such as cell modems.

To configure the serial interfaces, proceed with the following steps:

- ▶ Start LinkComm.



- ▶ Establish a connection to the data logger, see chapter Connecting LinkComm to the data logger [▶ 25].
- ▶ Click on the **Settings** button.
- ▶ Select the *Serial Ports* tab.
- ▶ Set the required transmission parameters of the interface (only for interfaces that are actually intended for connecting devices or sensors with Modbus protocol).
- ▶ Click on the yellow warning triangle.
 - ⇒ A window for sending the configuration to the data logger opens. (The yellow warning triangle indicates that the configuration within the operating software has changed.)
- ▶ Click on the **Send Configuration to Station** button.
 - ⇒ The software sends the changed configuration to the data logger.

9.1.8 Downloading, displaying and saving data

To download data (on site), proceed with the following steps:

- ▶ Start LinkComm.
- ▶ Establish a connection to the data logger, see chapter Connecting LinkComm to the data logger [▶ 25].
- ▶ Click on the **Data** button.
- ▶ Select the desired *Span*; set *Start Time/End Time*, if required.
- ▶ If required, click on the **Options ...** button and activate the *Include Events* checkbox.
 - ⇒ If the checkbox is activated, the software also downloads all events saved in a System Log and Service Log file, e.g. control value entries.
- ▶ Click on the **Download** button.
 - ⇒ The software downloads the data from the data logger to the PC or mobile device.
 - ⇒ Possibly the **Download** button is marked with *******, then the data displayed, does not (no longer) correspond to the selected time period.
- ▶ Then click on the **Download** button again.

To display data, proceed with the following steps:

- ✓ The data to be displayed had already been downloaded, see above.
- ▶ Click the view **Graph**.
 - ⇒ The software displays all measured values graphically.
- ▶ If required, click on  and activate or deactivate the checkbox for the desired measured values.
 - ⇒ The software scales the y-axis of the graphical display automatically, depending on the activated measured values.
- ▶ Click the view **Table** or **Table (grouped)**.
 - ⇒ The software displays all measured values in tabular form.
- ▶ If required, click on  and activate or deactivate the checkbox for the desired measured values.
- ▶ Click the view **Images**.
 - ⇒ The software displays a list with information about the available images.
- ▶ Click on the **Refresh** button.
- ▶ Select the desired images and click on the **Download** button.
 - ⇒ The software downloads the image files to the PC.

- ▶ Click on the **Image Files** button.
 - ⇒ The software opens a window with the storage location of the image files.
- ▶ Select images and open them with any app, e.g. Window Photo Viewer.
- ▶ Click the view **Events**.
 - ⇒ The software displays the content of the System Log file as a text file in table format.
- ▶ Click on the **Log Files ...** button.
 - ⇒ A Window Explorer window opens with the downloaded log files (txt, oml and csv; oml files only, if *Include Events* checkbox was selected during download).

To save data, proceed with the following steps:

- ▶ Click the view **Table** or **Table (grouped)**.
- ▶ Click on  and activate or deactivate the checkbox for the desired measured values.
- ▶ Optionally, when using the cvs-file format: click on the **Options ...** button.
 - ⇒ A window for configuring the cvs format opens.
- ▶ Make the required settings and click on **Close**.
- ▶ Click on the **Save File ...** button.
 - ⇒ A window for selection of the data format opens.
- ▶ Select the data format:

Data format	Description
CSV	structured text file in CSV-format (Comma-Separated Values)
MIS	OTT-specific file format (ASCII) for automatic import into the measured value database of the OTT Hydras 3 application software
OTTML	OTT-specific file format (OTT Markup Language) based on the markup language "XML" (Extensible Markup Language) Info data is available in OTTML and is explicitly provided for display and evaluation of data in the OTT Hydras 3 application software.
ZRXP	application-specific file format (software "WISKI" of the company Kisters).

- ▶ Click on the **OK** button.
 - ⇒ A window for setting file name, storage location and file extension opens.
- ▶ Make the required settings and click on **Save**.
 - ⇒ The software saves the selected measured values in a corresponding file (file format: *.cvs, *.mis, *.oml, *.zrxp).
- ▶ Click the view **Graph**.
- ▶ Click on  and activate or deactivate the checkbox for the desired measured values.
- ▶ Click on the **Save Image ...** button.
 - ⇒ A window for setting file name and storage location opens.
- ▶ Make the required settings and click on **Save As**
 - ⇒ The software saves the selected graph in a corresponding image file (file format: *.png).
- ▶ Click the view **Events**.

- ▶ Click on the **Save File ...** button.
 - ⇒ A window for setting file name, storage location and file extension (for special cases) opens.
- ▶ Make the required settings and click on **Save**.
 - ⇒ The software saves the events in a corresponding file (file format: **.oml*; can be changed to **.xml* or **.txt*).

9.1.9 Using service and main menu functions

There are various additional functions in LinkComm for operation, communication monitoring and troubleshooting.

To use the service functions, proceed with the following steps:

- ▶ Start LinkComm.
- ▶ Establish a connection to the data logger, see chapter Connecting LinkComm to the data logger [▶ 25].
- ▶ Click on the **Service** button.
- ▶ Select the appropriate tab from the menu.

Service tab	Tab/button	Description
<i>Diagnosis</i>	<i>Available Memory</i>	Available data volume of the internal storage, the microSD card and external storage media on the USB host interfaces.
	<i>Communication status</i>	Number of successful and failed data transmissions.
	<i>Operational Issues</i>	Detailed information on serious malfunctions of the data logger. In most cases, such events require on-site intervention to rectify the fault.
	Terminal button	Shows the communication flow between the operating software and the data logger. In addition, special commands can be sent to the data logger. This function is intended for very experienced and appropriately trained users and for OTT HydroService!
	Data Flow ... button	Shows the communication data flow between the operating software and the data logger. This function is intended for very experienced and appropriately trained users and for OTT HydroService!
	SDI-12 Command ... button	Provides a window for sending SDI-12 commands and configuring the SDI-12 interfaces for testing and maintenance purposes.
	Reset Power ... button	Shows the current status of the switched supply voltages (connection pins 13, 17, 24 and 28) in a separate window and enables these to be switched off individually for 3 seconds.
	Set to Defaults ... button	It is possible to reset the entire OTT XLink 2000 to factory settings or to delete certain sections individually.
	Reboot button	Reboots the OTT XLink 2000 (this disconnects the active communication connection).
<i>Support</i>		In this section there are contact options for OTT HydroMet technical support or a local contact person, helpful links to the device manual and other online resources as well as a function for exporting diagnostic information from the data logger.
<i>Firmware</i>		This tab provides information about the firmware version currently installed on the OTT XLink 2000 and checks whether a newer version is available. For detailed information, see chapter Updating firmware [▶ 49].

Service tab	Tab/button	Description
<i>System Logs</i>		The buttons on this tab are used to download log files from the data collector for any period of time and then display them by event type. The events can be saved in sequence in various customizable file formats.
<i>Station Info</i>		This window shows general information about the station and contains various technical details about the configuration of the data logger. An active communication connection is terminated, once this tab is entered.

To use the main menu functions, proceed with the following steps:

- ▶ Open the main menu.
- ▶ Select the appropriate tab from the menu.

Tab	Description
<i>Import Database ...</i>	Imports all stations (OTT XLink 2000 configurations) contained in a *.ldz file (database file) into the operating software.
<i>Export Database ...</i>	Exports all stations saved in the operating software (OTT XLink 2000 configurations) to a *.ldz file. This can be used for data backup and transfer of a large number of configurations.
<i>About ...</i>	Displays the version of the LinkComm operating software and other information.
<i>Options ...</i>	Opens a window for setting various LinkComm options: <ul style="list-style-type: none"> – Language: Language of the LinkComm user interface (German, English, French, Spanish) – Downloads: Specifies the location of the downloaded log files (log files) – Theme: Appearance of the LinkComm user interface – Other: Optionally activate <i>Hydromet Cloud Warnings</i> and "<i>Show Active FTP Warnings</i>".
<i>Event Log ...</i>	Shows the communication data flow between the operating software and the data logger. This function is intended for very experienced and appropriately trained users and for OTT HydroService!
<i>Contact Support ...</i>	For questions or concerns regarding LinkComm, customer service at www.otthydromet.com can be contacted.
<i>Send Feedback ...</i>	A window will open to submit suggestions for improvement and give feedback on the user-friendliness of the LinkComm operating software.
<i>Exit</i>	Exits the operating software (not available in the LinkComm apps for Android and iOS)

When a communication connection is active, the main menu is expanded to include the *Getting Settings from Station ...* function, and when the configuration has been changed but not yet synchronized, it is expanded to include the *Send Settings to Station ...* function.

- ▶ To add a newly created station to the list of available stations, use the *Save Station* function in the main menu.

9.2 Setting up remote data transmission

The following sections describe the setup of remote data transmission and are optionally required for commissioning.

9.2.1 Configuring communication devices

- ⓘ If remote data transmission is to take place via the cellular network, one or two cell modems must first be added during commissioning and the communication devices must be configured according to the individual requirements.

The data logger has a maximum of four communication devices for remote data transmission and for setting the operating parameters:

- 1 integrated Ethernet interface (LAN)
- 1 integrated Wi-Fi hotspot
- max. 1 external cell modem (connected to RS-232-1 or RS-232-2)

To add an optional cell modem and configure the communication devices, proceed with the following steps:

- ▶ Start LinkComm.
- ▶ Establish a connection to the data logger, see chapter Connecting LinkComm to the data logger [▶ 25].
- ▶ Click on the **Communication** button.
- ▶ Select the *Communication Devices* tab.
- ▶ If required, click on **Add Device** and select *Cell Modem* to add a cell modem as communication device.
- ▶ Click on the desired communication device in the list.
- ▶ Alternatively, click on  and select **Settings**
 - ⇒ A window for configuring the operating parameters opens.
- ▶ Configure the required operating parameters of the communication device.

If a communication device is not switched on continuously (*Always on*), but an incoming communication connection should still be possible at certain times, it is possible to add and configure a schedule:

- ▶ Click on **Add Schedule**.
- ▶ Click on the desired schedule in the list.
- ▶ Alternatively, click on  and select **Settings**
 - ⇒ A window for configuring the schedule opens.
- ▶ Configure the desired schedule.

If required, a communication device can be deleted:

- ▶ Click on  and select **Delete**.
- ▶ Confirm the confirmation prompt with **Delete**.

- ⓘ If the Ethernet interface or an external cell modem is not continuously switched on (*Always on*), the data logger automatically activates the corresponding interface when a data transmission is pending.

An external cell modem can be connected either directly to a power supply or via the switched power supply of the data logger (pin 13 and pin 17 + ground). In the latter case, the data logger also automatically activates the switched power supply when a data transmission is pending.

9.2.2 Configuring a network server

For remote data transmission, the data logger requires at least one network server as a receiver for the data to be transmitted. The data logger supports the following transmission protocols:

- Hypertext Transfer Protocol (HTTP)
- Hypertext Transfer Protocol Secure (HTTPS)
- File Transfer Protocol (FTP)
- File Transfer Protocol over TLS (FTPS)
- Secure File Transfer Protocol (SFTP)
- Simple Mail Transfer Protocol (SMTP)

 If remote data transmission should be used, at least one network server must be created during commissioning and configured according to the individual requirements.

To add and configure a network server, proceed with the following steps:

- ▶ Start LinkComm.
- ▶ Establish a connection to the data logger, see chapter Connecting LinkComm to the data logger [▶ 25].
- ▶ Click on the **Communication** button.
- ▶ Select the *Server* tab.
- ▶ Click on **Add Server** and select the desired server type from the list.
 - ⇒ The operating software creates a new server.
- ▶ Click on the newly created server in the list.
- ▶ Alternatively, click on  and select **Settings**
 - ⇒ A window for configuring the operating parameters opens.
- ▶ Configure the required operating parameters of the server.

If required, a server can be deleted:

- ▶ Click on  and select **Delete**.
- ▶ Confirm the confirmation prompt with **Delete**.

 By selecting the server type (HTTP/S, FTP/S, SFTP, SMTP), the operating software sets the corresponding port to a default value. If required this setting can be overwritten. (Default values: HTTP: 80; HTTPS: 443; FTP: 21; FTPS: 990; SFTP: 22; SMTP: 587.) By activating the **Use Secure Protocol** button, the transfer protocol is changed to HTTPS for the HTTP server type and to FTPS for the FTP server type.

If the **Activate Proxy Server** button is activated, the data logger establishes the connection to the receiving server via an HTTP proxy server. The settings for this proxy server can be changed in the operating parameters of the cell modem used.

9.2.3 Configuring a telemetry schedule

The data logger enables time-controlled remote data transmission either via the integrated Ethernet interface or an externally connected cell modem. Multiple schedules with different receivers and communication channels can be flexibly configured.

To add and configure a telemetry schedule, proceed with the following steps:

- ▶ Start LinkComm.
- ▶ Establish a connection to the data logger, see chapter Connecting LinkComm to the data logger [▶ 25].
- ▶ Click on the **Communication** button.
- ▶ Select the *Telemetry Schedules* tab.
- ▶ Click on **Add Transmission** and select the desired communication device from the list.
 - ⇒ The operating software creates a new transmission.
- ▶ Click on the newly created transmission in the list.
- ▶ Alternatively, click on  and select **Settings ...** .
 - ⇒ A window for configuring the operating parameters opens.
- ▶ Go to the *Transmission* section: set or select name, content type and desired data transmission format.
- ▶ Go to the *Schedule* section: set the transmission interval and time offset to 0 o'clock.
- ▶ If required, go to *Limit value intervals* and select the changed transmission interval. This interval is used automatically as soon as a limit value is reached. The general transmission interval can be changed temporarily via three additional, limit value-controlled time intervals.
- ▶ Enter server information.
- ▶ Activate the buttons for the measured values to be transferred in the selection list.

If required, a telemetry schedule can be deleted:



- ▶ Click on  and select **Delete**.
- ▶ Confirm the security prompt with **Delete**.

If required, monitor and test telemetry status

The operating software provides several functions for monitoring and testing a configured remote data transmission. There is an info box and five buttons at the bottom of the configuration window for this purpose (these only appear when connected to the station):

Button	Description
Refresh	refreshes the telemetry status of the OTT XLink 2000 displayed in the info box
Clear Counts	deletes the telemetry status displayed in the info box and resets the transmission counters to "0"
Transmit Now	starts an immediate data transmission (in addition to and independent of the defined schedule)
Test TX - OTTML	sends an empty OTT-ML file to the selected server to test the transmission path
Tx Diagnostics	displays diagnostic information on data transmission in a separate window

If an error has occurred during data transmission, a yellow warning triangle () is displayed with *Telemetry Status* above the info box.

- ▶ To acknowledge the error, press the **Clear Counter** button.
 - ⇒ The display changes from  to .

9.3 Operating XLink on site with LCD display and navigation pad

For on-site operation, the data logger is equipped with an LCD display (4 lines x 20 characters) and a navigation pad, see chapter Product overview [▶ 14]. The navigation pad includes four direction buttons and a confirmation button, which allow easy navigation through the menus and the entry of characters. (The user interface of the display is only available in English).

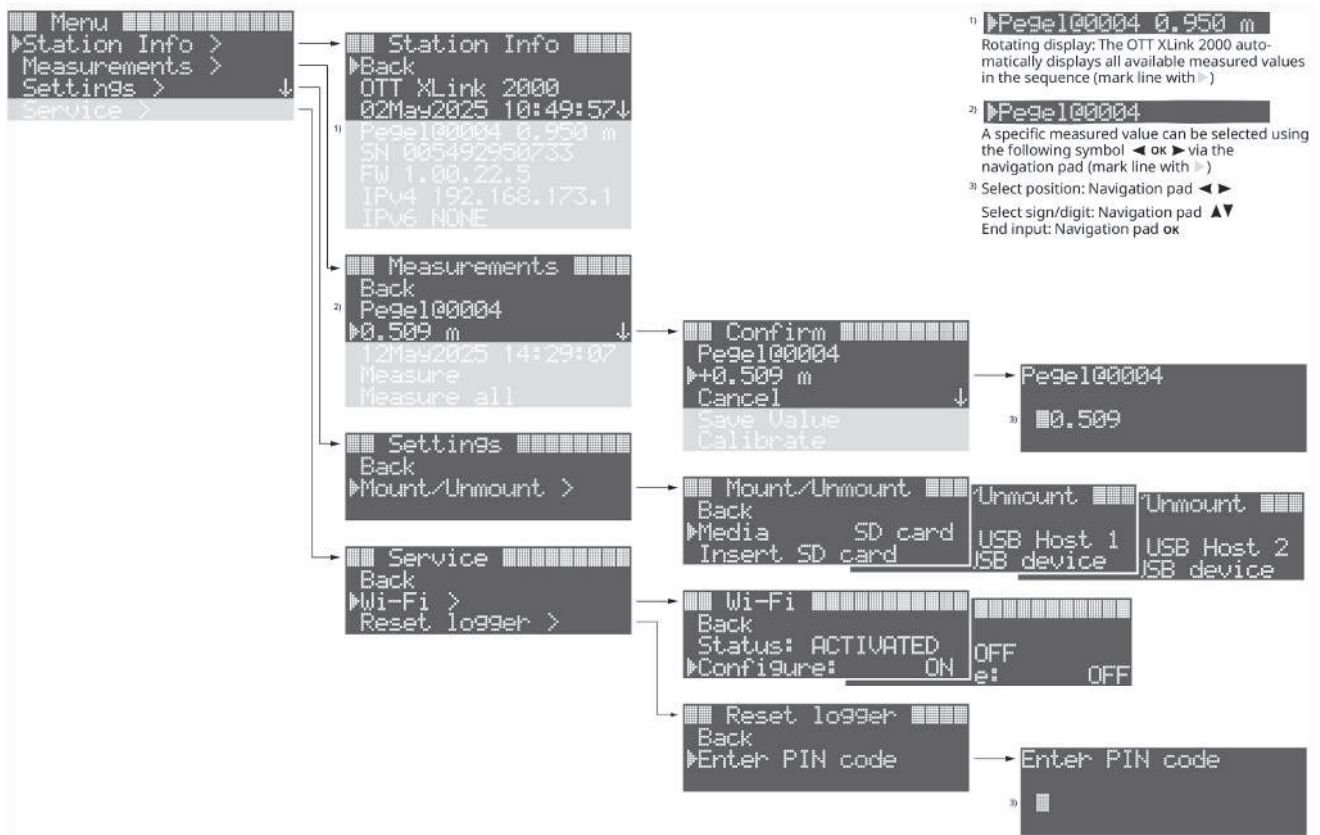

Menu structure of the LCD display

i The LCD display deactivates automatically 5 minutes after the last operating activity on the navigation pad.

The following sections describe the menu functions available on the LCD display of the data logger.

9.3.1 Entering pin

If protection against unauthorized device operation is activated in LinkComm, a pin has to be entered before it is possible to operate the navigation pad, see chapter Activating protection against unauthorized operation [▶ 31].

- ▶ Select *Enter PIN code* by pressing **OK** on the navigation pad.
 - ⇒ The display changes to the field to enter the pin code.
- ▶ Enter the six-digit pin code as defined in LinkComm.
- ▶ Press **OK**.
- ▶ In case of incorrect pin code, you have two further attempts to enter the pin.
 - ⇒ After three incorrect attempts, the device is permanently locked:
- ▶ Start LinkComm.
- ▶ Deactivate the protection against unauthorized device operation in the administrator access.
- ▶ Observe the timeout period after which the device locks itself again automatically.

9.3.2 Viewing station information

The *Station Info* menu function displays general information about the station and the last measured values.

- ▶ If required, enter the six-digit pin, see above.
- ▶ Select *Station Info* by pressing **OK** on the navigation pad.
 - ⇒ The display changes to the submenu with the following values:
 - station name
 - date and current time of the device
 - in rotating display: all measured values of the last query interval (name + ID + measured value)
 - serial number of the device
 - currently installed firmware version of the device
 - IPv4 Internet address (optional, Ethernet interface deactivated with *NONE*)
 - IPv6 Internet address (optional, Ethernet interface deactivated with *NONE*)
- ▶ Press the arrow keys UP ▲ and DOWN ▼, to display the lines above or below the current line.
- ▶ To return to the main menu, select *Back* and press **OK**.

9.3.3 Examining measurements

The *Measurements* menu displays the latest data from each measurement.

- ▶ If required, enter the six-digit pin.
- ▶ Use the arrow keys UP ▲ and DOWN ▼ and select *Measurements*.
- ▶ Select *Measurements* by pressing **OK** on the navigation pad.
 - ⇒ The display changes to the submenu.
- ▶ Use the arrow keys UP ▲ and DOWN ▼ to select the line with the measured values.
- ▶ Use the arrow keys LEFT ◀ and RIGHT ▶ to select the desired measured value.
 - ⇒ The display shows the measured value of the last query interval in the line below.
- ▶ If required, press DOWN ▼ to scroll down to display date and time of this measured value.
- ▶ To display another value, use the arrow keys UP ▲ and DOWN ▼ to scroll back to the line with the measured values.
- ▶ Use the arrow keys LEFT ◀ and RIGHT ▶ to select the next measured value.
 - ⇒ The display shows the measured value of the last query interval in the line below.
- ▶ To return to the main menu, select *Back* and press **OK**.

9.3.4 Taking measurements

In the *Measurements* menu, the *measure* item can take an instantaneous value measurement and then display the measurement result. This is either possible for a single measured value or for all measured values of the data logger.

- ▶ If required, enter the six-digit pin.
- ▶ Use the arrow keys UP ▲ and DOWN ▼ and select *Measurements*.
- ▶ Select *Measurements* by pressing **OK** on the navigation pad.
 - ⇒ The display changes to the submenu.
- ▶ To measure a single value, use the arrow keys UP ▲ and DOWN ▼ to select the line with the measured values.

- ▶ Use the arrow keys LEFT ◀ and RIGHT ▶ to select the desired measured value.
 - ⇒ The display shows the measured value of the last query interval in the line below.
- ▶ Use the arrow keys UP ▲ and DOWN ▼ and select *Measure*.
- ▶ Press **OK**.
 - ⇒ The data logger carries out an instantaneous value measurement of this measured value.
 - ⇒ The data logger updates the displayed value, and the date and time.
- ▶ To display another value, use the arrow keys UP ▲ and DOWN ▼ to scroll back to the line with the measured values.
- ▶ Use the arrow keys LEFT ◀ and RIGHT ▶ to select the next measured value.
- ▶ To measure, see steps described above.
- ▶ To measure all values, use the arrow keys UP ▲ and DOWN ▼ and select *Measure All*.
- ▶ Press **OK**.
 - ⇒ The data logger carries out an instantaneous value measurement of all values.
- ▶ Use the arrow keys UP ▲ and DOWN ▼ and select the line with the measured values.
- ▶ Use the arrow keys LEFT ◀ and RIGHT ▶ to select the desired measured value.
 - ⇒ The display shows the measurement result, and the date and time.
- ▶ Use the arrow keys LEFT ◀ and RIGHT ▶ to select the next measured value.
 - ⇒ The display shows the measurement result, and the date and time.
- ▶ To return to the main menu, select *Back* and press **OK**.

9.3.5 Entering control values

In the *Measurements* menu, manually determined control values can be entered via *Save Value*. This is possible for all measured values of the data logger.

- ▶ If required, enter the six-digit pin.
- ▶ Use the arrow keys UP ▲ and DOWN ▼ and select *Measurements*.
- ▶ Select *Measurements* by pressing **OK** on the navigation pad.
 - ⇒ The display changes to the submenu.
- ▶ Use the arrow keys UP ▲ and DOWN ▼ to select the line with the measured values.
- ▶ Use the arrow keys LEFT ◀ and RIGHT ▶ to select the desired measured value.
 - ⇒ The display shows the measured value of the last query interval in the line below.
- ▶ Use the arrow key DOWN ▼ and select the line with the desired measured value.
- ▶ Press **OK**.
 - ⇒ The display changes to a submenu for entering a control value.
- ▶ Use the arrow key DOWN ▼ to scroll to the line with the desired measured value.
- ▶ Press **OK**.
- ▶ Enter a control value.
- ▶ Use the arrow keys UP ▲, DOWN ▼ and RIGHT ▶ to enter the control value (including sign).
- ▶ Press **OK**.
 - ⇒ The display switches back to the submenu for confirming the control value.
- ▶ Use the arrow key DOWN ▼ to select *Save Value*.

- ▶ Press **OK**.
 - ⇒ The data logger saves the entered control value in the measured value memory.
- ▶ To enter further control values, use the arrow keys UP ▲ and DOWN ▼ to scroll back to the line with the measured values.
- ▶ Use the arrow keys LEFT ◀ and RIGHT ▶ to select the next measured value.
- ▶ To enter a value, see steps described above.
- ▶ To return to the main menu, select *Back* and press **OK**.

9.3.6 Scaling measurements

In the *Measurements* menu, reference values can be entered via the *Calibrate* menu. The data logger calculates an offset from the difference between the instantaneous and reference values. This offset is stored in the measurement module under processing and is subsequently used to scale the measured values for all further measurements.

- ✓ The configuration of a measured value that is to enable the entry of a reference value must contain the "Offset" procedure under *Processing*.
 - ▶ If required, enter the six-digit pin.
 - ▶ To obtain a current measured value for the offset calculation, first start an instantaneous value measurement, see chapter Taking measurements [▶ 44].
 - ▶ Use the arrow keys UP ▲ and DOWN ▼ and select *Measurements*.
 - ▶ Select *Measurements* by pressing **OK** on the navigation pad.
 - ⇒ The display changes to the submenu.
 - ▶ Use the arrow keys UP ▲ and DOWN ▼ to select the line with the measured values.
 - ▶ Use the arrow keys LEFT ◀ and RIGHT ▶ to select the desired measured value.
 - ⇒ The display shows the measured value of the last query interval in the line below.
 - ▶ Use the arrow key DOWN ▼ and select the line with the desired measured value.
 - ▶ Press **OK**.
 - ⇒ The display changes to a submenu for entering a reference value.
 - ▶ Use the arrow key DOWN ▼ to scroll to the line with the desired measured value.
 - ▶ Press **OK**.
 - ▶ Enter a reference value.
 - ▶ Use the arrow keys UP ▲, DOWN ▼ and RIGHT ▶ to enter the reference value (including sign).
 - ▶ Press **OK**.
 - ⇒ The display switches back to the submenu for confirming the reference value.
 - ▶ Use the arrow key DOWN ▼ to select *Calibrate*.
 - ▶ Press **OK**.
 - ⇒ The data logger calculates an offset from the difference between the instantaneous and reference values and transfers this to the measuring module.
 - ⇒ The data logger saves the entered reference value in the measured value memory.
 - ▶ To enter further reference values, use the arrow keys UP ▲ and DOWN ▼ to scroll back to the line with the measured values.
 - ▶ Use the arrow keys LEFT ◀ and RIGHT ▶ to select the next measured value.
 - ▶ Continue with the steps described above.

- ▶ To return to the main menu, select *Back* and press **OK**.

9.3.7 Connecting external removable storage media

To use a micro SD card or another removable storage medium on the USB host interfaces, the respective storage medium must be "mounted" in the file system of the data logger when connecting it and "unmounted" before removing it.



- ✓ The interface to which the storage medium is connected must always be enabled in advance using LinkComm, see chapter Activating connections for external removable storage media [▶ 31].
- ▶ If required, enter the six-digit pin.
- ▶ Use the arrow keys UP ▲ and DOWN ▼ and select *Settings*.
- ▶ Press **OK**.
 - ⇒ The display changes to the submenu.
- ▶ Use the arrow keys UP ▲ and DOWN ▼ and select *Mount/Unmount*.
- ▶ Press **OK**.
 - ⇒ The display changes to the submenu.
- ▶ Use the arrow keys UP ▲ and DOWN ▼ and select *Media*.
- ▶ Use the arrow keys LEFT ◀ and RIGHT ▶ to select micro SD card or USB host interface 1/2.
- ▶ To mount the storage medium: insert the storage medium into the card slot (micro SD card) or the USB host interface 1/2 (USB A socket).
- ▶ Use the arrow keys UP ▲ and DOWN ▼ and select *Mount*
- ▶ Press **OK**.
 - ⇒ The data logger mounts the selected storage medium.
- ▶ To unmount the storage medium: use the arrow keys UP ▲ and DOWN ▼ and select *Unmount*
- ▶ Press **OK**.
 - ⇒ The data logger unmounts the selected storage medium.
- ▶ Remove the storage medium.
- ▶ To return to the main menu, select *Back* two times and press **OK**.

9.3.8 Configuring Wi-Fi connection

The data logger has an integrated Wi-Fi hotspot for establishing a communication connection on site. The Wi-Fi hotspot can either be activated permanently or temporarily (using a schedule) in LinkComm or alternatively, the Wi-Fi hotspot can be activated or deactivated directly on the device if required.

To activate/deactivate the Wi-Fi hotspot directly on the device, proceed with the following steps:

- ✓ The Station Wi-Fi communication device must always be enabled in advance using LinkComm, see chapter Configuring communication devices [▶ 40].
- ▶ If required, enter the six-digit pin.
- ▶ Use the arrow keys UP ▲ and DOWN ▼ and select *Service*.
- ▶ Press **OK**.
 - ⇒ The display changes to the submenu.
- ▶ Use the arrow keys UP ▲ and DOWN ▼ and select *Wi-Fi*.

- ▶ Press **OK**.
 - ⇒ The display changes to the submenu.
- ▶ Use the arrow keys UP ▲ and DOWN ▼ and select *Configure*.
- ▶ Use the arrow keys LEFT ◀ and RIGHT ▶ and select *ON* or *OFF*.
 - ⇒ The data logger activates or deactivates the Wi-Fi hotspot.
 - ⇒ The display shows *Status: ACTIVATED* or *Status: OFF*.
- 
- ⇒ With activated Wi-Fi hotspot, the LED  flashes blue.
- ▶ To return to the main menu, select *Back* two times and press **OK**.

To activate/deactivate the Wi-Fi hotspot through LinkComm, proceed with the following steps:

- ▶ Start LinkComm.
- ▶ Establish a connection to the data logger, see chapter Connecting LinkComm to the data logger [▶ 25].
- ▶ Click on the **Communication** button.
- ▶ Select the *Communication Devices* tab.
- ▶ Click the Station Wi-Fi button to the right to turn on.
- ▶ Select *Settings*.
 - ⇒ A window for configuring the operating parameters opens.
- ▶ Configure the required operating parameters of the Station Wi-Fi.

9.3.9 Resetting to factory settings

The data logger can be reset to factory settings. If necessary, the measured values can be readout and the previous configuration exported before the reset.

For resetting the data logger a four-digit PIN is required, which corresponds to the last four digits of the device's serial number, see type plate or *Station Info* menu, see chapter Viewing station information [▶ 44].

- ▶ If required, enter the six-digit pin.
- ▶ Use the arrow keys UP ▲ and DOWN ▼ and select *Service*.
- ▶ Press **OK**.
 - ⇒ The display changes to the submenu.
- ▶ Use the arrow keys UP ▲ and DOWN ▼ and select *Reset Logger*.
- ▶ Press **OK**.
 - ⇒ The display changes to the submenu.
- ▶ Use the arrow keys UP ▲ and DOWN ▼ and select *Enter PIN code*.
- ▶ Press **OK**.
- ▶ Use the arrow keys UP ▲, DOWN ▼ and RIGHT ▶ and enter the four-digit PIN.
- ▶ Press **OK**.
 - ⇒ The data logger resets to factory settings and restarts.
- ▶ To return to the main menu, use UP ▲ and DOWN ▼ two times, select *Back* and press **OK**.

10 Maintenance

10.1 Maintenance schedule

The frequency of cleaning is dependent upon the local weather and environmental conditions.

The following maintenance works are recommended for all devices:

Interval	Activity	Performed by
Minimum once per year	<ul style="list-style-type: none">▶ Clean the device carefully using a brush with soft bristles, if necessary.▶ Do not use water or liquid cleaning agents on the device.	Operator
Minimum once per year	<ul style="list-style-type: none">▶ Check if the system LED is flashing red or an error message is displayed.	Operator
Annually	<ul style="list-style-type: none">▶ Check all electrical connections.▶ Check all cables for damage.▶ Check the instrument mounting.	Operator
5 years	<ul style="list-style-type: none">▶ Replace the backup battery real-time clock.	OTT HydroMet

10.2 Updating firmware

If required, the OTT XLink 2000 firmware (operating software) can be updated. This can be useful, for example, if devices were delivered at different times and should receive the same firmware version. The update is carried out via LinkComm. LinkComm independently checks in the background whether a new firmware version is available on the OTT HydroMet server. An update can be carried out both via a local communication connection or via remote access.

- ✓ The communication connection must not be interrupted.
 - ✓ Do not start any other programs or apps during the copying process.
 - ✓ The power supply must not be interrupted.
 - ▶ Start LinkComm.
 - ▶ Establish a connection to the data logger, see chapter Connecting LinkComm to the data logger [▶ 25].
 - ▶ Click on the **Service** button.
 - ▶ Select the *Firmware* tab.
 - ⇒ LinkComm checks which firmware is currently installed and whether a newer version is available. The following storage locations are checked:
1. the OTT HydroMet server (prerequisite: the PC must have an Internet connection)
 2. the directory *.../Documents/LinkComm/Firmware* on the PC
 - ▶ If the latest firmware is on the OTT HydroMet server, click on the **Download and Install** button.
 - ▶ If the latest firmware is only to be downloaded to the PC and not installed, click on  and then **Download**.
 - ▶ If the latest firmware is already on the PC, click the **Install** button.
 - ▶ Confirm the security prompt with *Next*.
 - ⇒ The software carries out the update automatically in five steps.
 - ⇒ A separate window in the software shows the progress of the update.
 - ▶ Click on the **Close** button once the update completes.

11 Troubleshooting

11.1 Error elimination

Error	Possible cause	Corrective action
Sensor failure	<p>SDI-12 sensor: Error is recorded when the SDI-12 sensor does not reply to the measure and to the data commands</p> <p>Analog sensor: Error is recorded when analog to digital converter cannot read the input, such as input voltage being out of range or not being connected</p>	<ul style="list-style-type: none"> ▶ Check the sensor wiring. ▶ Replace the sensor.
Meas interval too short	<p>Error is recorded when the station missed a scheduled measurement: likely due to measurement taking longer than <i>Meas Interval</i> to complete - e.g. system should measure every 5 seconds, but sensor takes 10 seconds to complete</p> <p><i>Equations</i> are enabled and the <i>Meas Interval</i> is short (once a second or once every two seconds). The system may take several seconds to compute a lengthy equation and cannot complete a measurement as quickly and the system realizes that more than one measurement interval has been passed between two subsequent measurements</p>	<ul style="list-style-type: none"> ▶ Increase the measurement interval.
Sampling too short	<p>Sensor response time is longer than the sampling interval; for SDI-12 readings e.g., the error occurs, if a sensor requires 10 seconds to produce a reading and the sampling interval is 10 seconds</p>	<ul style="list-style-type: none"> ▶ Increase the sampling interval.
Averaging too short	<p>The averaging interval is shorter than the sampling interval or than the sensor reply time</p>	<ul style="list-style-type: none"> ▶ Increase the averaging interval or decrease the sampling interval.
Bad setup	<p>Error is recorded to indicate one of the following:</p> <ul style="list-style-type: none"> – The equation processor reported an error. This can be a divide by 0 or syntax error – The meta measurement referenced an inappropriate measurement – The SDI-12 command was set to an invalid value – The SDI-12 sensor did not provide enough data values in the result (<i>check SDI-12 Param</i>) 	<ul style="list-style-type: none"> ▶ Check the equation. ▶ Check the meta measurement setup. ▶ Check the SDI-12 command. ▶ Check the SDI-12 parameter.

Error	Possible cause	Corrective action
Time not set	The system does not have valid time	<ul style="list-style-type: none"> ▶ Set the clock. ▶ Alternatively, if a cell or Iridium modem is installed, wait for the system to get network time.
Battery low	The system considers any battery voltage below 10.00 V to be an error, indicating that the battery needs to be changed. The system does not make any measurements or transmissions when the voltage is too low	<ul style="list-style-type: none"> ▶ Replace the battery, or provide a sufficient power supply.
Transmission failures	<p>Error is recorded to indicate one of the following:</p> <ul style="list-style-type: none"> – Two or more consecutive transmissions fail – More than 25 % of total transmissions fail – No measurements are set up to be included in the transmission data 	<ul style="list-style-type: none"> ▶ Check the status to find the reason for the failures.
Hardware failure	Any hardware issues noted since boot up. The hardware error is also placed in the log with a code and indicates a serious problem with the device.	<ul style="list-style-type: none"> ▶ Contact the OTT HydroMet customer service representatives.
Device transmits an unknown – error value		<ul style="list-style-type: none"> ▶ Check if the error can be cleared with the LinkComm Clear button on the service tab under operational issues. ▶ If the error cannot be cleared, then contact the technical support department of OTT HydroMet.

12 Repair

12.1 Customer support

- ▶ Have repairs carried out by OTT HydroMet service personnel.
- ▶ Only carry out repairs yourself, if you have first consulted OTT HydroMet.
- ▶ Contact your local representative: www.otthydromet.com/en/contact-us
- ▶ Include the following information:
 - instrument model
 - instrument serial number
 - details of the fault or problem
 - examples of data files
 - readout device or data acquisition system
 - interfaces and power supplies
 - history of any previous repairs or modifications
 - pictures of the installation
 - overview of the local environment conditions



OTT HydroMet repair service

13 Notes on disposing of old devices

Member States of the European Union

In accordance with the German Electrical and Electronic Equipment Act (ElektroG; national implementation of EU Directive 2012/19/EU), OTT HydroMet takes back old devices in the Member States of the European Union and disposes of them in the proper manner. The devices that this concerns are labeled with the following symbol:



- ▶ For further information on the take-back procedure contact OTT HydroMet:

OTT HydroMet GmbH
Ludwigstraße 16
87437 Kempten
Germany
phone: +49 831 5617 430
email: hydroservice@ott.com

All other countries

- ▶ Dispose of the product in the proper manner following decommissioning.
- ▶ Observe the country-specific regulations on disposing of electronic equipment.
- ▶ Do NOT dispose of the product in household waste.

13.1 Disposing integrated lithium coin cell

The data logger contains an integrated lithium coin cell (type: CR2032) as a buffer battery for the real-time clock. Before disposing of the device, the coin cell must be removed and disposed of separately:

- ▶ Remove all screw terminal strips.
- ▶ Loosen and remove the four hexagon socket screws on the back of the device.
- ▶ Loosen and remove the four hexagon socket screws on the display circuit board.
- ▶ Remove the display circuit board.
- ▶ Remove the lithium coin cell from the holder.
- ▶ Properly dispose of the coin cell.

14 Technical data

14.1 Dimensions and weight

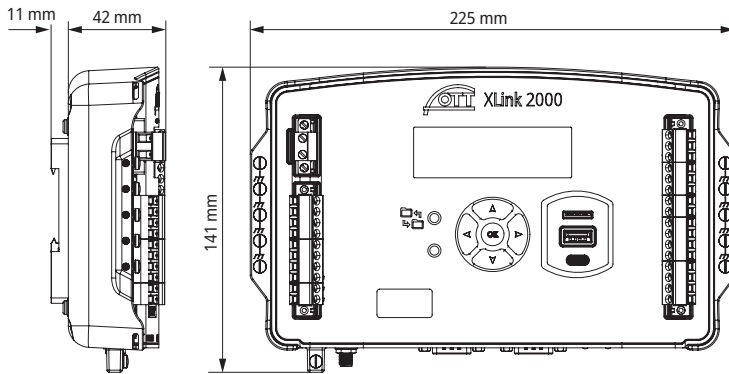

XLink 2000

Specification	Value
Instrument weight	1000 g (2.2 lbs)
Packaging weight (device incl. Wi-Fi antenna and packaging)	1300 g (2.9 lbs)
Dimensions housing	225 mm x 131 mm x 42 mm (8.86 in x 5.18 in x 1.65 mm)
Dimensions unpacked (incl. screw terminal strip, connectors and mounting)	225 mm x 141 mm x 53 mm (886 in x 5.55 in x 2.1 in)
Packaging dimensions	333 mm x 222 mm x 70 mm (13.11 in x 8.74 in x 2.76 in)

14.2 Electrical data

Specification	Value
Protection type	IP40
Operating temperature range	-40 °C to +70 °C
Storage temperature range	-40 °C to +70 °C
Humidity range (non-condensing)	0 to 100 %
Max. cable length (with 1.0 mm ²) with 12 V	max. 9 m
Max. cable length (with 1.0 mm ²) with 24 V	max. 65 m
Power consumption	max. 6 A
Cross-section of conductor for power supply	min. 1.0 mm ² (AWG 17)
Recommended conductor cross-section for grounding cable	4.0 mm ² (AWG 11)
Connection capacity of screw terminal strips: one conductor, rigid or flexible	0.2 mm ² to 2.5 mm ² (AWG 24 - AWG 12)
Connection capacity of screw terminal strips: two conductors (same cross-section), rigid	0.2 mm ² to 1.0 mm ² (AWG 24 - AWG 17)

Specification	Value
Connection capacity of screw terminal strips: two conductors (same cross-section), flexible	0.2 mm ² to 1.5 mm ² (AWG 24 - AWG 15)
Stripping length conductor	7 mm
Supply voltage (in standard applications)	10 – 28 V DC; typical 12 V DC/24 V DC
Supply voltage (via USB-C interface)	5 V DC; exclusively for device configuration via a PC
Power consumption @ 12 V DC, active	40 mA (data logger only)
Power consumption @ 12 V DC, sleep mode	< 25 mA
Analog inputs	
Voltage input unbalanced	
Number	4
Input range	0 – 0.025 V; 0 – 5 V
Accuracy	±0.05 % FS
Resolution	0.6 µV
Voltage input differential	
Quantity	2
Differential input range	± 5 V (each input must not exceed the input range of the unbalanced voltage input)
Accuracy	±0.05 % FS
Resolution	0.6 µV
Further analog inputs	<ul style="list-style-type: none"> – sensors with ohmic resistance; 3-/4-wire connection – platinum temperature sensors – sensors with resistance measuring bridge; 4-wire connection – sensors with potentiometer; 3-wire connection – stage discharge recorder SDR – analog wind speed sensors (cup anemometer)
4 - 20 mA input	
Number	1
Range	0 - 22 mA
Accuracy @ 25 °C	0.1 % error at FS
Precision voltage reference	
VREF	2.5 V
Accuracy	±0.002 V
Digital inputs	
Digital/frequency input	
Number	2
Type	1 pulse input
Sensors possible to connect	<ul style="list-style-type: none"> – sensors with pulse output (DC voltage signal) – sensors with frequency output (AC voltage signal) – status sensor – wind speed sensors (cup anemometers) with frequency output

Specification	Value
	<ul style="list-style-type: none"> - wind direction sensors with frequency output - tipping bucket rain gauge
Frequency	max. 10 kHz
DV voltage range	3 – 28 V
Additional function	Optional debouncing of the input signal
Internal sensors	<ul style="list-style-type: none"> - refer to temperature of the device housing - relative humidity in the device housing - level of supply voltage
Outputs	
Number	5
Type	<ul style="list-style-type: none"> - switched supply voltage: SDI-12 (2 x); RS-485 (2 x) - VREF (1 x)
Overcurrent protection	
SDI-12	0.5 A
RS-485	1.0 A
VREF	10 mA
Interfaces	
SDI-12 interface	
Quantity	2 (electrically independent of each other)
Interface design	SDI-12 specification version 1.4
Overcurrent protection (Pin 24 + 27)	yes; 0.5 A
RS-485 interface	
Quantity	2
Protocol	SDI-12 via RS-485; Modbus, Lufft UMB
RS-232 interface (EIA-485)	
Quantity	2
Connectors	D-Sub; 9-pin; male
Transmission speed	<ul style="list-style-type: none"> - Modbus: max 115.200 Bit/s - cell modem: max 1 Mbit/s
Ethernet interface	
Number	1
Power over Ethernet	no
Plug connector	RJ-45
Transmission speed	up to 1 Gbit/s Ethernet
Compatibility IP cameras	compatible with IP cameras with REST-API (HTTP/HTTPS)
Extension bus	
Number	1
Plug connector	RJ-25
Interfaces for external data storage	<ul style="list-style-type: none"> - 2 x USB-A Host - slot for microSD card

Specification	Value
Interfaces for local communication connection	USB-C device
Data storage	
Available data storage for measured values	8 GB
Reserved for operating system	2 GB
Sample interval	1 second to 24 hours
Data communication	
Transmission interval	1 minute to 24 hours
Communication channels	Ethernet LAN, cell, Wi-Fi
IP communication protocols	FTP, FTPS, SFTP, HTTP, HTTPS
Encryption (SSL)	TLS 1.3
Cipher suites	all algorithms supported
Clock	
Type	battery-buffered real-time clock
Accuracy	±16 seconds/month (at -40°C to +70°C)
Type of buffer battery	CR 2032; 3 V
Buffer battery lifetime	5 years
Configurable settings and options	
Station information	Location of the measuring site including photo, map and notes (this information is stored exclusively in the LinkComm software)
Measured value processing	<ul style="list-style-type: none"> - Scaling - Offset - Min/Max values - Mean value - Sum - Median - Delta storage
Event-driven actions	See actions below
User profiles	<i>Administrator, Configurator, Viewer</i>
Trigger conditions and actions	
Measured value processing	Compare measured values with defined limit values
System events	<ul style="list-style-type: none"> - Restart - Communication error - Enter control values
Event-driven actions	<ul style="list-style-type: none"> - Change configuration - Change date and time - Update firmware - Wake up data logger - Perform measurement - Change polling interval

Specification	Value
	<ul style="list-style-type: none">- Change data transmission interval- Take photo/video- Perform data transmission- Send notification- Control switched supply voltage
LED displays	
Device status	green, red
Status Wi-Fi	off, blue



Contact Information

