

Operating instructions
IP Datalogger
OTT netDL 500
OTT netDL 1000

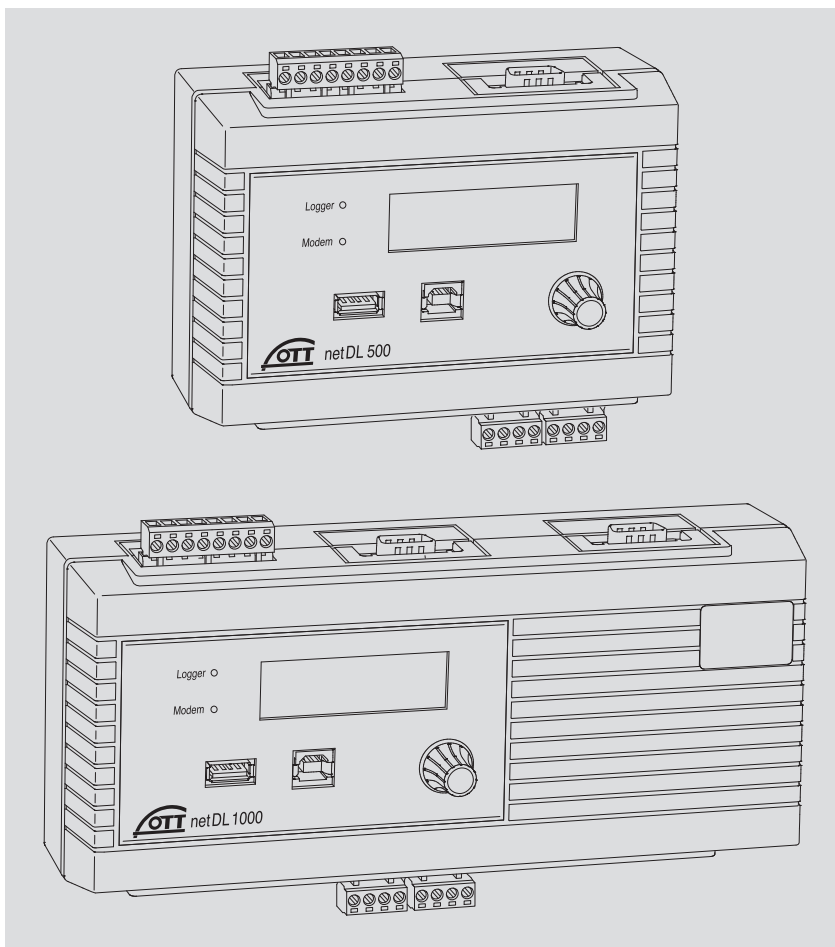

We reserve the right to make technical changes and improvements without notice.

Table of contents

1	Scope of supply	5
2	Ordering numbers and version code	5
3	General safety information	9
4	About these operating instructions	10
5	Introduction	11
5.1	Overview of the OTT netDL IP datalogger	13
6	Overview: Starting up the OTT netDL unit	16
7	Installing the OTT netDL unit	17
7.1	Attaching the datalogger	17
7.2	Overview of the locations of the screw terminal strips and RS-232 interfaces	19
7.3	Connecting sensors having an RS-485 interface (2-wire)	20
7.4	Connecting sensors having an SDI-12 interface	21
7.5	Connecting sensors having a pulse output	21
7.6	Connecting equipment having a status output	21
7.7	Connecting sensors having a voltage output	22
7.8	Connecting sensors having a current output	22
7.9	Connecting the Pt 100 temperature sensor	23
7.10	Connecting sensors having a potentiometer (5 kOhms)	23
7.11	Connecting sensors having an RS-232 interface	24
7.12	Connecting switching contacts	24
7.13	Connecting 4-20 mA outputs	25
7.14	Connecting status outputs	26
7.15	Connecting the power supply to the OTT netDL unit	26
7.16	Connecting the radio antenna and inserting the SIM card	27
7.17	Connecting external communication equipment	28
7.18	Connecting an Ethernet LAN or DSL router	29
7.19	IP coupling	29
7.20	Connecting the USB device interface	31
7.21	Connecting the USB host interface	31
7.22	Connecting the IP camera	32
7.23	Connecting the satellite transmitter	34
8	Setting OTT netDL operating parameters	36
8.1	Installing the OTT Data Logger Operating Program	36
8.2	Establishing the PC/OTT netDL communication link (on site)	36
8.3	Introduction: Setting OTT netDL operating parameters	38
9	Operating/configuring the OTT netDL unit on site	39
9.1	Detecting and displaying instantaneous values(Observer function)	39
9.2	Entering observer texts(extended Observer function)	41
9.3	Scaling instantaneous values/stored values (set offset)	42
9.4	Displaying/setting date and time	43
9.5	Entering manual values into a manual sensor	43
9.6	Displaying information on Internet transmissions	44
9.7	Displaying information on connections	45
9.8	Displaying system information	46
9.9	Starting the voice announcer (on site)	47
9.10	Using a USB stick with the OTT netDL	47
10	LED indicators	50

11 Reading out measured data on site	51
12 Updating the OTT netDL firmware	52
13 Overview: Alarm and action management	53
14 Protecting the OTT netDL unit using a password	54
15 Setting date and time	55
16 Deleting the data memory	55
17 Creating and printing the terminal connection	56
18 Creating and printing a device view	56
19 OTT-SDI Transparent mode	57
20 Voice announcer functionality overview	59
21 Error messages	60
21.1 Internal error messages	60
21.2 External error messages	60
21.3 Sensor error messages	60
21.4 Error messages of the processing modules	61
22 Maintenance	62
23 Repair	62
24 Notes about the disposal of used units	63
25 Technical data	64
Appendix A – OTT netDL 500 / OTT netDL 1000 Declaration of Conformity	68
Appendix B – Special application: connecting four sensors with voltage-/ power output to an analog input card	69
B.1 Input combination "0/4-20 mA, internal supply"+"0-5/10 V"	70
B.2 Input combination "0/4-20 mA, external supply"+"0-5/10 V"	70
B.3 Input combination "0/4-20 mA, external supply" +"0-50 mV/1.25 V"	71
B.4 Input combination 2 x "0-5/0 V"	71
B.5 Input combination 2 x "0/4-20 mA, external supply"	72

1 Scope of supply

- ▶ **OTT netDL 500**
OTT netDL 1000
 - 1 IP datalogger incl. 4 physical input channels (1 x RS-485, 1 x SDI-12, 2 x pulse/status (OTT netDL 1000: 4 x), 2 switching outputs, RS-232 interface (OTT netDL 1000: 2 x), USB host/USB device interface, Ethernet interface (RJ-45; OTT netDL 1000), power supply/ground connector, 4 MB measurement memory, LCD display, 2 status LEDs and jog shuttle; incl. two (OTT netDL 500) or three (OTT netDL 1000) slots for expansion cards; optional cellular modem (version code "B...", "C..." and "D...")
 - 1 universal power supply connector kit
 - 1 operating instructions
 - 1 factory acceptance test (FAT) certificate

2 Ordering numbers and version code

- | | | |
|-------------------------|--|--|
| ▶ OTT netDL 500 | IP datalogger
incl. two slots for expansion cards <ul style="list-style-type: none">- Standard version- as "A.." + cellular modem GSM/GPRS- as "A.." + cellular modem GSM/GPRS including audio codec module* for voice announcer- as "A.." + cellular modem GSM/GPRS/UMTS/HSPA+ | 55.553.001.9.0
A ..
B ..
C ..
D .. |
| ▶ OTT netDL 1000 | IP datalogger
incl. three slots for expansion cards <ul style="list-style-type: none">- Standard version- as "A..." + cellular modem GSM/GPRS- as "A..." + cellular modem GSM/GPRS including audio codec module* for voice announcer- as "A..." + cellular modem GSM/GPRS/UMTS/HSPA+ | 55.552.001.9.0
A ...
B ...
C ...
D ... |
- * digital encoder/decoder for audio devices

▶ Hardware Expansions	Analog input card	.1
	2 inputs for analog input signals	
	– 0-20 mA / 4-20 mA	
	– 0-50 mV / 0-1.25 V / 0-5 V / 0-10 V	
	– Potentiometer, 5 kOhms	
	– Pt 100	
	Analog input card, galvanically isolated	.2
	Same input signals as for analog input card (see above)	
	RS-232 input card	.3
	for OTT sensors with RS-232 interface	
	Output card	.4
	Galvanically isolated output signals	
	– 2 outputs (4-20 mA)	
	– 4 status outputs (4 x 1 bit; 100 mA)	
	Barometric input card	.5
	For connecting a maximum of two pressure probes containing Keller absolute pressure cells	
	Absolutdruckmesszellen der Firma Keller	
▶ Software Expansions	Voice announcer functionality; default*	56.SLA.01M.O.1
	– Standard voice files may be individually compiled for the desired announcer text	
	Voice announcer functionality; custom*	56.SLA.01M.O.2
	– Custom announcer texts incl. factory setting provided by OTT	
	120 Channels*	55.552.309.9.3
	enables the creation of max. 120 logical channels (default: 40)	
External IP devices*	55.552.308.9.3	
– connection for IP camera (webcam)		
– IP coupling of several OTT netDL 1000		
External fieldbus*	56.SLA.01M.O.4	
enables the connection of the OTT netDL 500 / 1000 to an external fieldbus with protocol converter UNIGATE CL by "Deutschmann"		
– for PROFINET Standard		
– for PROFIBUS Standard		
– for Modbus RTU Standard		
PLC Siemens SIMATIC S7*	56.SLA.01M.O.3	
enables the connection of the OTT netDL 1000 to the programmable logic control Siemens SIMATIC S7 via Ethernet interface		

* included in the scope of delivery or for subsequent activation by registration code (serial number required)

► **Version code**

OTT netDL 500

- Device versions:	A...; B...; C...; D...				
- without expansion card:	.00				
- with one expansion card:	.10	.20	.30	.40	.50
- with two expansion cards:	.11	.22	.33	.44	.55
	.12	.23	.34	.45	
	.13	.24	.35		
	.14	.25			
	.15				

OTT netDL 1000

- Device versions:	A...; B...; C...; D...				
- without expansion card:	.000				
- with one expansion card:	.100	.200	.300	.400	.500
- with two expansion cards:	.110	.220	.330	.440	.550
	.120	.230	.340	.450	
	.130	.240	.350		
	.140	.250			
	.150				
- with three expansion cards:	.111	.222	.333	.444	.555
	.112	.223	.334	.445	
	.113	.224	.335	.455	
	.114	.225	.244		
	.115	.233	.245		
	.122	.234	.255		
	.123	.235			
	.124	.244			
	.125	.245			
	.133	.255			
	.134				
	.135				
	.144				
	.145				
	.155				

Examples

OTT netDL 1000 standard version;
 2 RS-232 input cards, 1 barometric input card
 Ordering number: 55.552.001.9.0
 Version code: A335

OTT netDL 500 standard version + cellular modem GSM/GPRS;
 1 analog input card, 1 output card
 Ordering number: 55.553.001.9.0
 Version code: B14

► **Accessories**

OTT netDL/PC data transfer cable 1.5 meters, 9-pin Sub-D socket/9-pin Sub-D plug	97.961.069.9.5
Modem connection cable 1.8 meters, 9-pin Sub-D socket/9-pin Sub-D socket	97.961.068.9.5
USB connection cable – USB connector type A to USB connector type B, 3 m	97.970.065.9.5
Flat antenna for cellular modem for GSM/GPRS/UMTS/HSPA+ – with 0.5 m connection cable – with 1.0 m connection cable – with 1.5 m connection cable	97.980.131.9.5 97.980.132.9.5 97.980.133.9.5
Resistor set for analog input card Metalfilm precision resistors for extension from two to four voltage/current inputs; ±0.1 % tolerance; 0.125 watts; 4 x 50 Ω; 2 x 10 kΩ; 2 x 100 kΩ	55.552.089.9.2
Resistor set for sensors with Modbus protocol Pull-up/Pull-down resistors for connection of special Modbus sensors to the RS-485 input; ±1 % tolerance; 0.6 watts; 1 x 1.2 kΩ; 1 x 2.7 kΩ Pull-up: 2.7 kΩ between RS-485 B and +12 V Pull-down: 1.2 kΩ between RS-485 A and GND	55.552.091.9.2
Protocol converter (Deutschmann) for connection to an external fieldbus; preconfigured; connection to OTT netDL 500 / 1000 via RS-232 interface – UNIGATE CL-PROFINET – UNIGATE CL-PROFIBUS DP – UNIGATE CL-RS (Modbus RTU)	97.970.103.9.5 97.970.125.9.5 97.970.104.9.5
Protocol converter connection cable 1.3 meters, 9-pin Sub-D-socket/ open cable ends (3 wires)	55.552.110.4.2
External cellular modem 3G EU-version; GSM/GPRS/UMTS/HSPA+	97.970.129.9.5
External cellular modem 4G EU-version; GSM/GPRS/UMTS/HSPA+/LTE	97.970.130.9.5
USB stick "OTT Hydromet Software" – with USB interface driver – with OTT Data Logger Operating Program – with standard configurations for OTT netDL 500 and 1000 – with backup file of supplied firmware version	56.575.001.9.7

3 General safety information



- ▶ Read these operating instructions before using the OTT netDL for the first time! Become completely familiar with the installation and operation of the OTT netDL and its accessories!
- ▶ Note any additional information on dangers given within the individual work steps.
- ▶ Only use the OTT netDL and its accessories in the manner described in these operating instructions.
- ▶ Make sure that the installation site is sufficiently protected against moisture (IP 41 type of protection)!
- ▶ Select the installation site so that the ambient temperature never exceeds or falls below the allowable temperature range of -40 °C to $+70\text{ °C}$ (for device versions B..., C... and D... : -30 °C to $+70\text{ °C}$)!
- ▶ Install the OTT netDL in a closed control cabinet or in a fire protection cabinet! If the power supply of OTT netDL is a low power source (LPS), this is not necessary.
- ▶ Do not open the OTT netDL unit! Sensors, communication equipment, power supply, switching contacts, or additional components are connected only through the screw terminal strips/9-pin Sub-D connectors accessible from outside.
- ▶ Operate an OTT netDL unit with built-in cellular modem (device versions B..., C... and D...) only with the radio antenna connected.
Minimum clearance between antenna and unit or people: 20 cm!
- ▶ Before connecting the power supply, check that all wires are properly attached to the screw terminal strips and/or 9-pin Sub D connectors.
- ▶ It is essential to comply with the electrical limits given in the "Technical Data" section.
- ▶ Connect the OTT netDL only to a power supply providing less than 28 V_{DC} . Protect the feed line of the supply voltage with a safety fuse (10 A / fast)!
- ▶ Always use a galvanically isolated safety extra-low voltage (SELV) for mains supply.
- ▶ Do not make any changes or retrofits to the OTT netDL!
- ▶ Have a defective OTT netDL checked and repaired by the OTT repair center. Under no circumstances carry out any repairs yourself.



Please note: With a nearly full data memory in the OTT netDL unit, it may take a few minutes after an interruption of the operating voltage until communication is possible again!

Federal Communications Commission (FCC) Approval

Note: This equipment has been tested and found to comply with the limits for a Class A digital device, pursuant to part 15 of the FCC Rules. These limits are designed to provide reasonable protection against harmful interference when the equipment is operated in a commercial environment. This equipment generates, uses, and can radiate radio frequency energy and, if not installed and used in accordance with the instruction manual, may cause harmful interference to radio communications. Operation of this equipment in a residential area is likely to cause harmful interference in which case the user will be required to correct the interference at his own expense.

4 About these operating instructions

These operating instructions (revision "04-0917") cover the OTT netDL software versions

- ▶ OTT netDL firmware (operating system) from **V 3.02.0**
- ▶ OTT Data Logger Operating Program from **V 3.02.0**

The version of the operating program can be found via the "Info" feature in the "Help" menu.

Fig. 1: Info panel of the OTT netDL operating program showing the current release number.

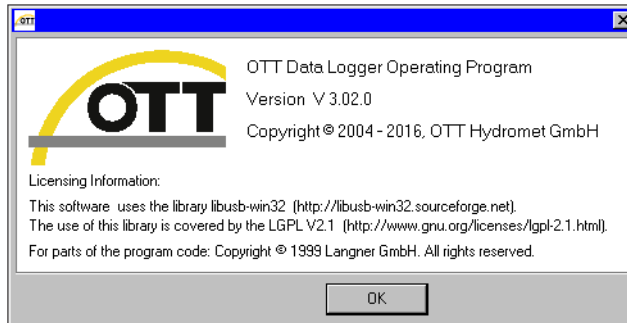

The version of the OTT netDL firmware is found in the master data window (refer to online help) after the OTT netDL configuration has been read into the operating program.

In Chapter 12 "Updating the OTT netDL firmware" you will find a description on how to update the OTT netDL firmware.

5 Introduction

The OTT netDL unit is an Internet protocol (IP) enabled datalogger that is especially designed for hydrometry, meteorology and environmental measuring technology. It is available in two models: OTT netDL 500 and OTT netDL 1000.

Fig. 2: OTT netDL IP datalogger

Top: OTT netDL 500
Bottom: OTT netDL 1000

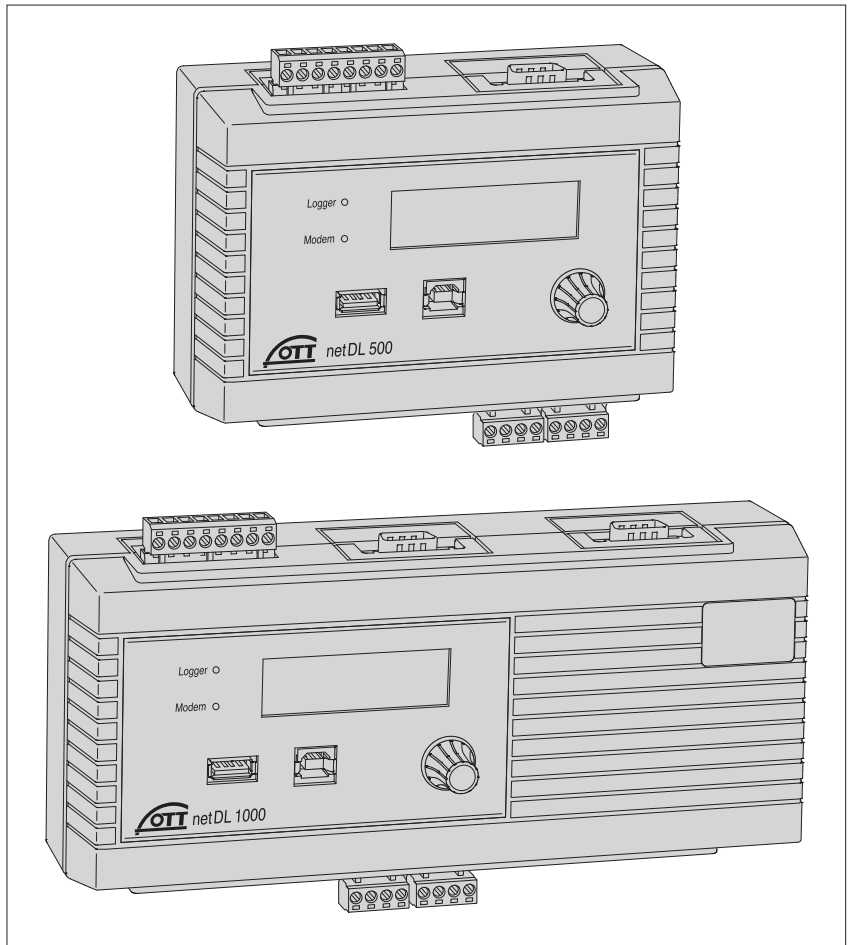

The standard version of each datalogger provides four physical input channels, an LCD display, and a jog shuttle. (The jog shuttle is a special operating button that can be rotated and pressed.) On request, the OTT netDL is available including different expansion cards (OTT netDL 500: 2 slots; OTT net DL 1000: 3 slots) and a built-in cellular modem. Additionally, OTT netDL 1000 has an Ethernet interface as well as a second serial interface.

Plug-in screw terminal strips allow easy connection of sensors and power supply without having to open the unit. Two LEDs show the operating states of the datalogger as well as of the cellular modem.

Configuration and parametrization are carried out using the "OTT Data Logger Operating Program" PC software. This software allows the system to be conveniently and flexibly tailored to a wide range of measurement requirements of a station.

All inputs are equipped with an internal overvoltage protection. The very low power consumption allows the unit to be operated with solar power without problem.

Using the internal or external cellular modem, remote data communication as well as remote parametrization may be done over the cellular network.

The remote data communication can be optionally carried out via a dial-up telephone connection, by SMS text messages, or using transmission services GSM, GPRS, UMTS or HSPA. The OTT netDL 1000 unit also provides remote data communication through the Ethernet interface. Similarly, remote data communication may be carried out via a satellite transmitter or a cable modem.

Furthermore, the OTT netDL has individually configurable alarm and action management: If particular events occur, OTT netDL independently generates an alarm and sends this via a modem e.g. to a control center. It is also possible to control external devices via switching contacts.

For both OTT netDL models, optional voice announcer functionality is available. It allows measured values and alarm messages to be announced through a dial-up connection. This functionality requires a voice-enabled modem (analog or ISDN) or the internal cellular modem (C... version code) to be used. Depending on the particular requirements, OTT will configure custom announcer texts or provide standard voice modules for individually compiling the announcer texts. When an external analog modem is used, measured values may also be announced on site.

Fig. 3: Datalogger front panels with the status LEDs, USB interfaces (left: Host; right: Device), and the plug-in screw terminal strips.

The figure shows the OTT netDL 500 unit including two expansion cards and internal cellular modem and the OTT netDL 1000 standard version without any expansion cards.

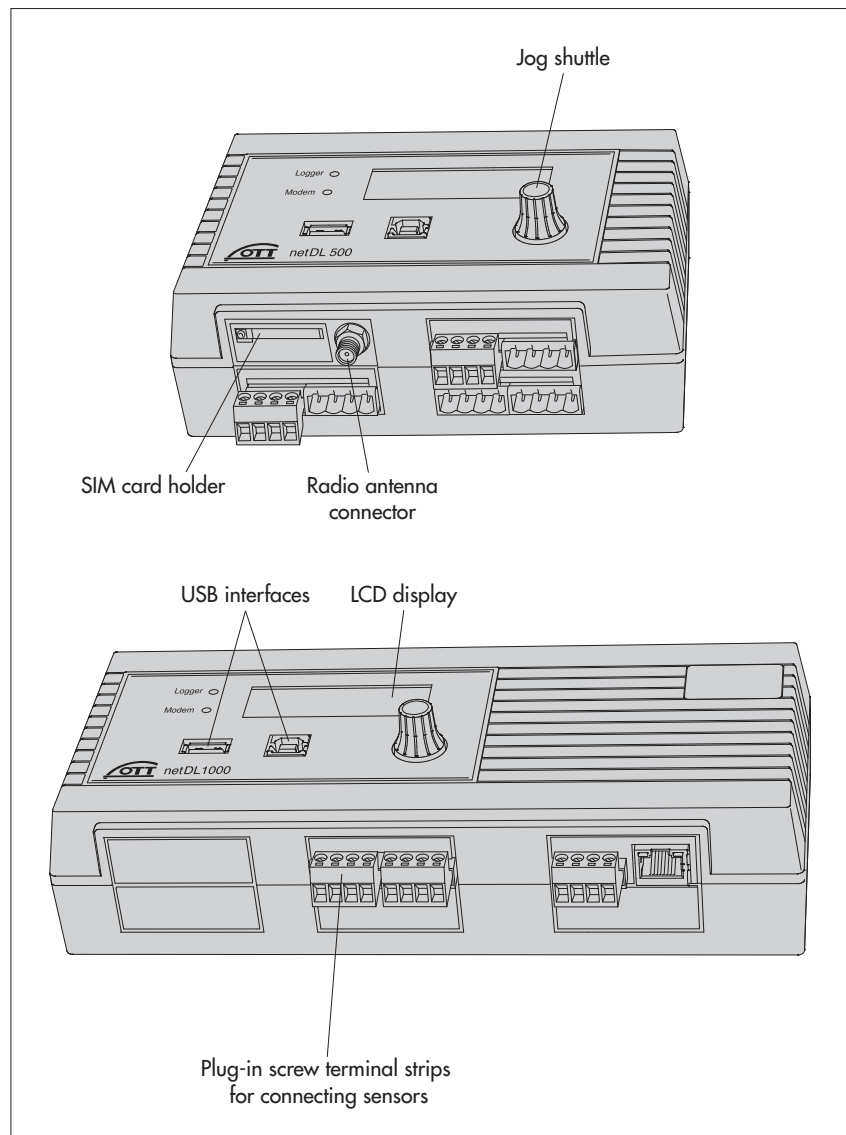
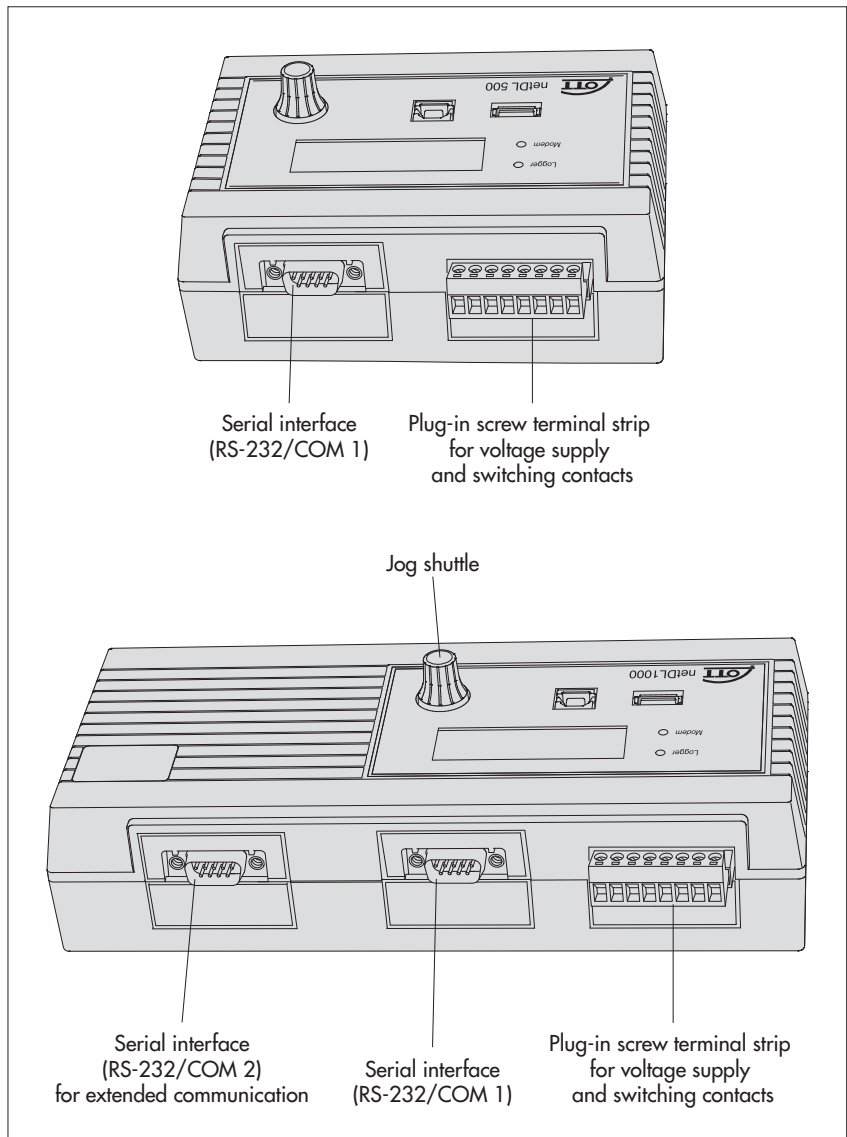

Fig. 4: Datalogger rear panels including the screw terminal strips for power supply and switching contacts.



5.1 Overview of the OTT netDL IP datalogger

Sensor inputs

- ▶ RS-485 interface (e.g. OTT RLS radar sensor, OTT Parsivel², third-party sensors providing Modbus communication protocol)
- ▶ RS-232 interface (OTT protocol, e.g. Nimbus bubble sensor) *
- ▶ SDI-12 interface (e.g. Hydrolab HL4, Hydrolab HL7)
- ▶ IP sensor (via Ethernet interface; webcam, OTT netDL 1000 IP coupling)
- ▶ Sensors in an external PROFINET or PROFIBUS DP fieldbus via UNIGATE CL protocol converter (Deutschmann)
- ▶ OTT Parsivel² Spectrum via RS-485 interface
- ▶ Pulse input
- ▶ Status input (2 x 1 bit)
- ▶ 0-50 mV, 0-1.25 V, 0-5 V, 0-10 V voltage input *
- ▶ (0) 4-20 mA input (current loop) *
- ▶ Pt 100 (temperature sensor) *
- ▶ 5 kOhm potentiometer *

* only with hardware expansion "Analog input card" / "RS-232 input card"

- ▶ Supply voltage (internal)
- ▶ Signal strength cellular network
- ▶ Monitoring switching output
- ▶ Monitoring status output
- ▶ Monitoring 4-20 mA output

Communication interfaces

- ▶ RS-232 interface
- ▶ USB host interface
- ▶ USB device interface
- ▶ Ethernet interface (OTT netDL 1000)
- ▶ Terminal mode
- ▶ OTT-SDI transparent mode

Sensor protocols

- ▶ SDI-12
- ▶ SDI-12 via RS-485
- ▶ Modbus RTU via RS-485

Data formats

- ▶ OTT protocol
- ▶ OTT Binary (XL)
- ▶ MIS (ASCII)
- ▶ OTT ML (XML)
- ▶ CSV
- ▶ ZRXP / ZRXP 3.0 (Kisters AG)
- ▶ Crex-Code (satellite communication)
- ▶ Custom built (satellite communication)

IP communication protocols

- ▶ FTP (File Transfer Protocol)
- ▶ HTTP (Hypertext Transfer Protocol);
- ▶ HTTPS (Hypertext Transfer Protocol Secure); SSL 3.0 / TLS 1.0, 1.1, 1.2)
- ▶ Socket (Stream or datagram socket)
- ▶ SMTP (Simple Mail Transfer Protocol)

Outputs

- ▶ Potential-free switching output (with output card)
- ▶ Voltage output for supply of sensors (switched U_{bat})

The outputs switch e.g. modem, sensor supply, or alarm devices (potential-free switching output via relay).

- ▶ 4-20 mA output

Measured value processing

- ▶ Sample interval; internal/external
- ▶ Mean calculation
- ▶ Totals formation
- ▶ Scaling "ax + b"
- ▶ Two-point scaling
- ▶ Delta storage
- ▶ Definition of a sensor delay time
- ▶ Extreme value collection (minimum/maximum)
- ▶ Filter functions
- ▶ Extreme value recording
- ▶ Linearization table
- ▶ Arithmetic function
- ▶ Dewpoint calculation

- ▶ "Q"-calculation
- ▶ Tendency determination
- ▶ Date value capturing
- ▶ Virtual terminal/virtual sensor (logical channels)
- ▶ Alarm-/action management: Limit monitoring (threshold/gradient); status action

Reading out/data transmission

- ▶ Reading out on site via RS-232 and USB interface
- ▶ Reading out via modem
- ▶ Independent data transmission via modem, terminal adapter, satellite transmitter or IP communication protocols
- ▶ ISDN D channel data transmission possible (X.31)
- ▶ Comprehensive action management (transmission of alarm messages, control of switching outputs, change of sample-/storage interval, voice announcer, data transmission, ...)

Operating/display elements

- ▶ LCD display
- ▶ Jog-Shuttle
- ▶ LED (logger, modem)

Optional: Voice announcer functionality (internal/external)

- ▶ General text
- ▶ Pause
- ▶ Instantaneous value
- ▶ Stored value
- ▶ Stored value time
- ▶ Tendency
- ▶ Date values
- ▶ Encoded value/status
- ▶ Virtual terminal
- ▶ Virtual terminal time
- ▶ Retry

Optional: 120 channels

enables the creation of max. 120 logical channels (default: 40)

Optional: External IP devices

- ▶ Connection for IP camera (webcam)
- ▶ IP coupling of several OTT netDL 1000

Optional: External fieldbus

enables the connection of the OTT netDL 500 / 1000 to an external fieldbus with-protocol converter UNIGATE CL by "Deutschmann"

- for PROFINET Standard
- for PROFIBUS Standard
- for Modbus RTU Standard

Optional: PLS Siemens SIMATIC S7

enables the connection of the OTT netDL 1000 to the programmable logic control Siemens SIMATIC S7 via Ethernet interface

6 Overview: Starting up the OTT netDL unit

Starting up an OTT netDL unit is done in a maximum of 10 steps:

	Refer to chapter
1. Device versions "B...", "C..." and "D...": Inserting the SIM card	7.16
2. Attaching the datalogger	7.1
3. Connecting sensors	from 7.2
4. Connecting switching contacts*	7.12
5. Connecting 4-20 mA outputs*	7.13
6. Connecting status outputs*	7.14
7. Connecting the power supply	7.15
8. Device versions "B...", "C..." and "D...": Connecting the radio antenna	7.16
9. Installing and connecting external communication equipment*	7.17
10. OTT netDL 1000: Connecting an Ethernet LAN or DSL router*	7.18
11. Configuring the datalogger and setting operating parameters (also refer to the online help of the operating program)	8

* Only if required

7 Installing the OTT netDL unit

7.1 Attaching the datalogger

Requirements of the intended installation site:

- ▶ Sufficient protection from moisture (IP 41 protection type).
- ▶ Properly determined space for the electrical cables.
- ▶ The following operating temperature ranges are kept:
 - Device version A... : -40 °C up to +70 °C
 - Device versions B..., C... and D... : -30 °C up to +70 °C
- ▶ Standard top hat rail (TS 35) mounted at installation site.
- ▶ Closed control cabinet or fire protection cabinet.
(not required if the power supply of OTT netDL is a low power source)

The dimensions of the OTT netDL can be found in Fig. 6.



Please note: Do not open the OTT netDL unit during installation! There are no adjustment or operating elements or connecting means inside the housing.

- Engage the OTT netDL unit into the top hat rail as shown in Figure 5 (left). Press the underside of the OTT netDL unit against the top hat rail until it clicks into place.

Fig. 5: Fastening the OTT netDL unit to the top hat rail (left)/removing it from the rail (right).

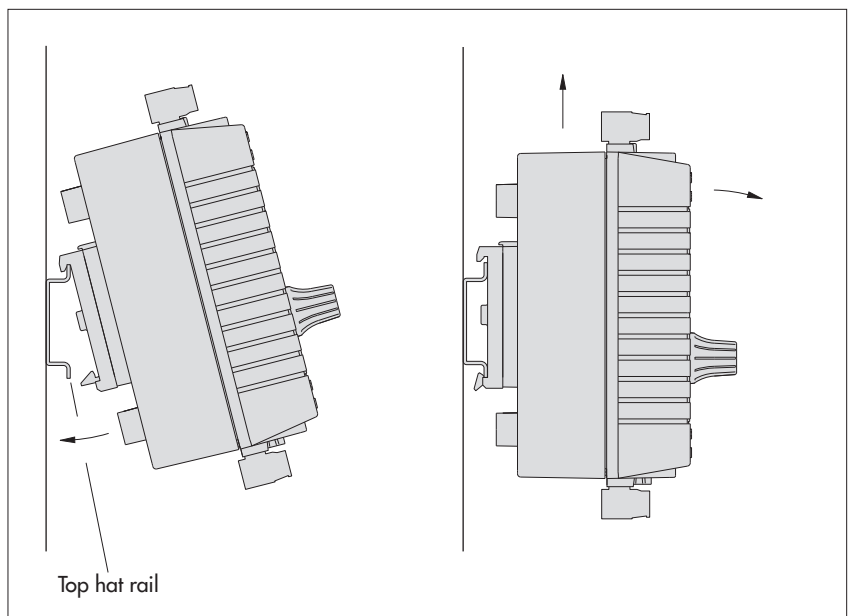

- Removing the OTT netDL unit: Carefully push the unit a few millimeters upward, slightly tilt the underside towards your body, and then remove it from the top hat rail, refer to Figure 5 (right).

Fig. 6: OTT netDL unit dimensions;
Top: OTT netDL 500
Bottom: OTT netDL 1000

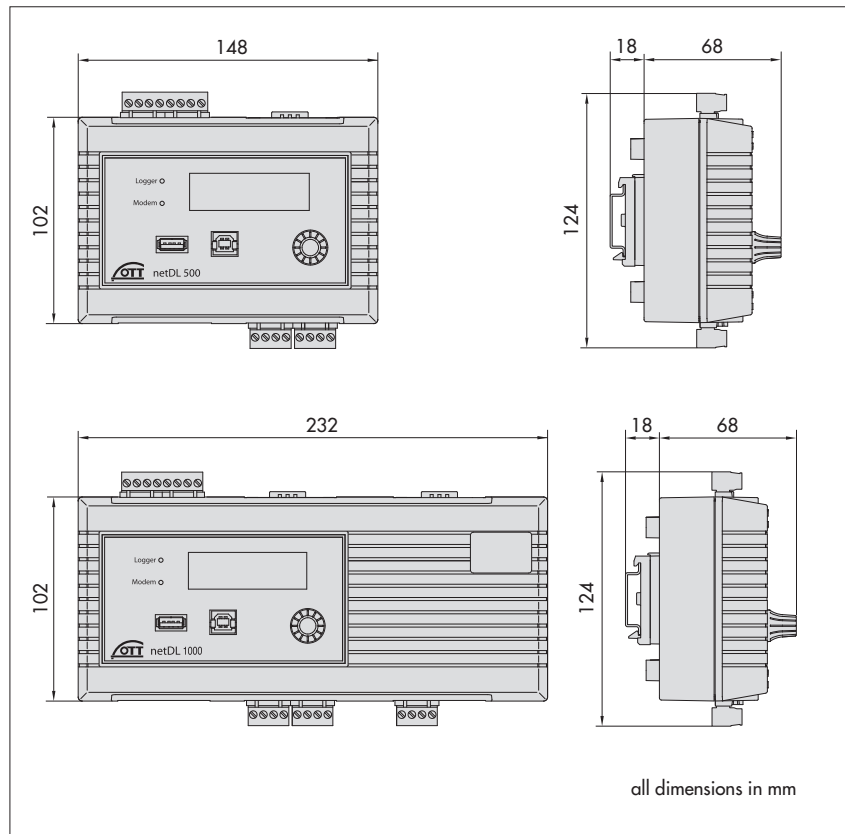

7.2 Overview of the locations of the screw terminal strips and RS-232 interfaces

Fig. 7: Available positions for the plug-in screw terminal strips.

The figure shows the OTT netDL 1000 unit without expansion cards.

Factory configuration
(without expansion cards):
OTT netDL 500: C, D + O-P
OTT netDL 1000: C-E + O-P

The specific configuration of your unit including expansion cards as well as the positions of the screw terminal strips/RS-232 interfaces can be obtained from the Factory Acceptance Test (FAT) Certificate attached.

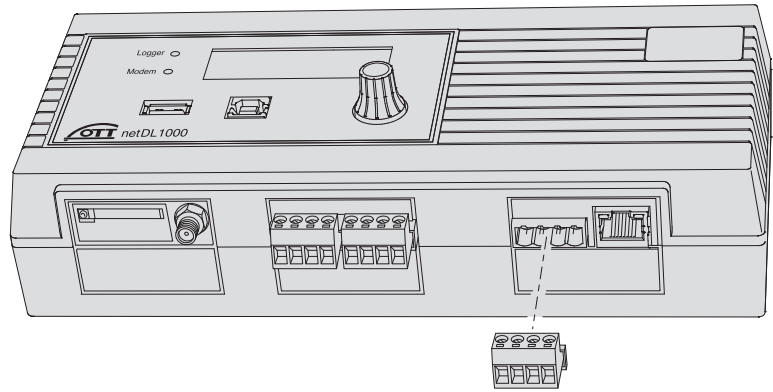

OTT netDL ...	500	1000	
Voltage supply/ switching contacts¹⁾ Screw terminal strip	N	N	
Connection of sensors Screw terminal strip	C, D + G ... K ²⁾	C ... E + G ... M ²⁾	
4-20 mA outputs Screw terminal strip	S-T; U-V	S-T; U-V; W-X	
Status outputs Screw terminal strip	G-H; J-K	G-H; J-K; L-M	
RS-232 interfaces Communication COM 1 COM 2 Serial sensor input ³⁾	O-P - G-H; J-K	O-P Q-R G-H; J-K; L-M	
			1 DCD 6 DSR 2 RXD 7 RTS 3 TXD 8 CTS 4 DTR 9 RI 5 GND

¹⁾ max. 5 A

²⁾ G ... K + G ... M only with expansion cards

³⁾ only with RS-232 input card

7.3 Connecting sensors having an RS-485 interface (2-wire)

Fig. 8: Connecting RS-485 interface sensors to the OTT netDL unit (e. g. OTT Parsivel² (Spectrum) Present Weather Sensor, OTT RLS radar sensor, or third-party sensors providing Modbus communication protocol). Possible communication protocols: SDI-12 via RS-485, OTT protocol, or Modbus.

If multiple sensors are to be connected to an OTT netDL unit, it is to be done using an RS-485 bus topology. Different communication protocols are not allowed to be used on the same RS-485-bus!

Further information can be found in the operating instructions of the respective sensor.

The GND connection represented by the dashed line is necessary only in case the sensor and the OTT netDL unit are supplied from different power supplies.

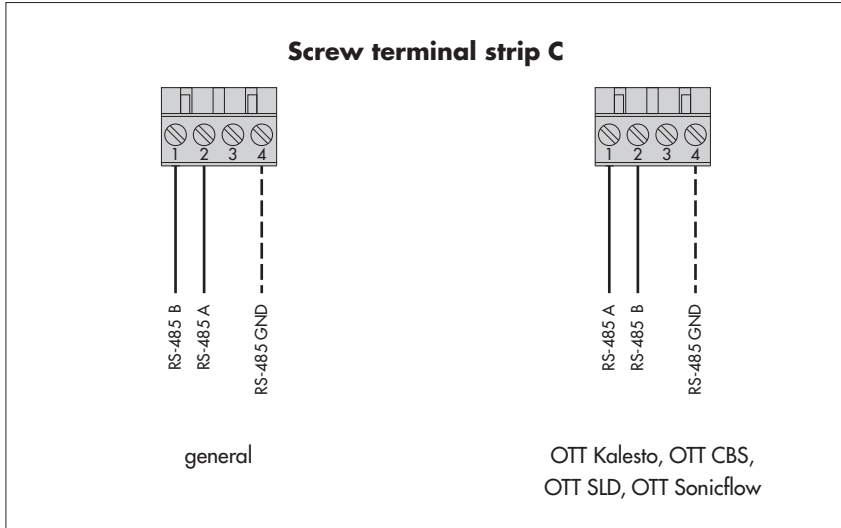

Note

- Some sensors using the Modbus communication protocol (e. g. Hach Solitax sc Sonden, ICPCON M-7015 analog module) require Pull-up/Pull-down resistors (see accessories) for connection to the RS-485 interface.

Abb. 9: Connecting the side looking doppler OTT SLD unit to the OTT netDL using the RS-485-interface (SDI-12 via RS-485).

The GND connection represented by the dashed line is necessary only in case the OTT SLD and the OTT netDL unit are supplied from different power supplies.

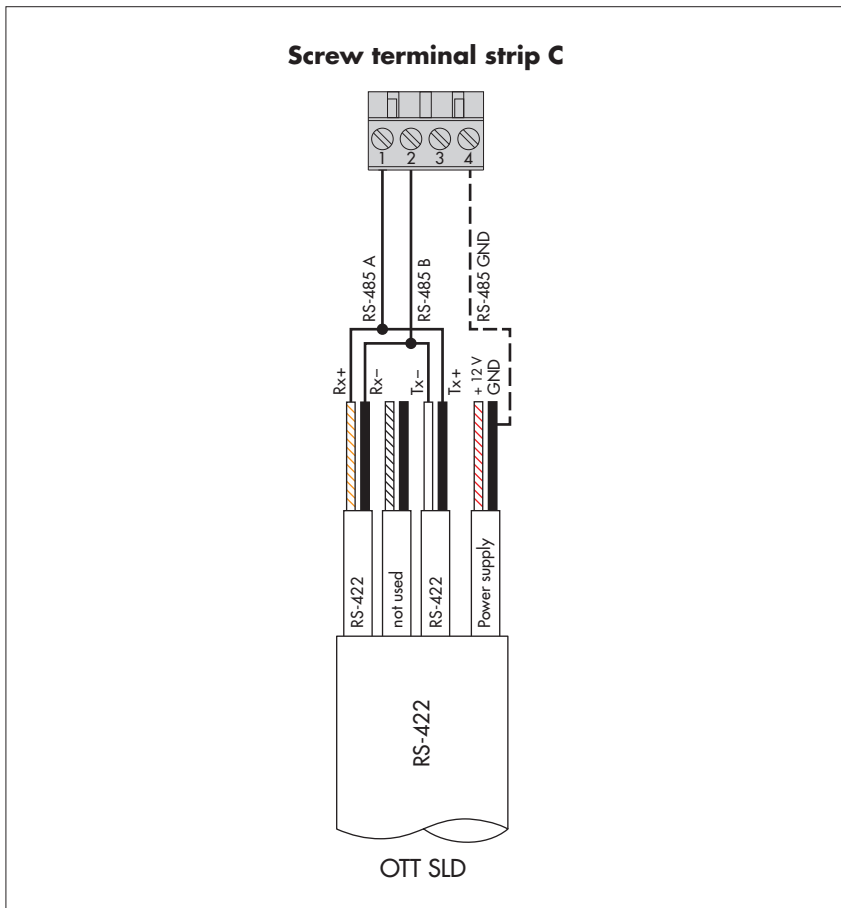

7.4 Connecting sensors having an SDI-12 interface

Fig. 10: Connecting sensors with SDI-12 interface to the OTT netDL unit (e.g. Hydrolab HL4/HL7). If multiple sensors are to be connected to an OTT netDL unit, it is to be done using an SDI-12 bus topology.

Further information can be found in the operating instructions of the respective sensor.

A sensor with SDI-12 protocol via RS-485 interface (e.g. OTT RLS radar sensor) is to be connected as shown in Chapter 7.3!

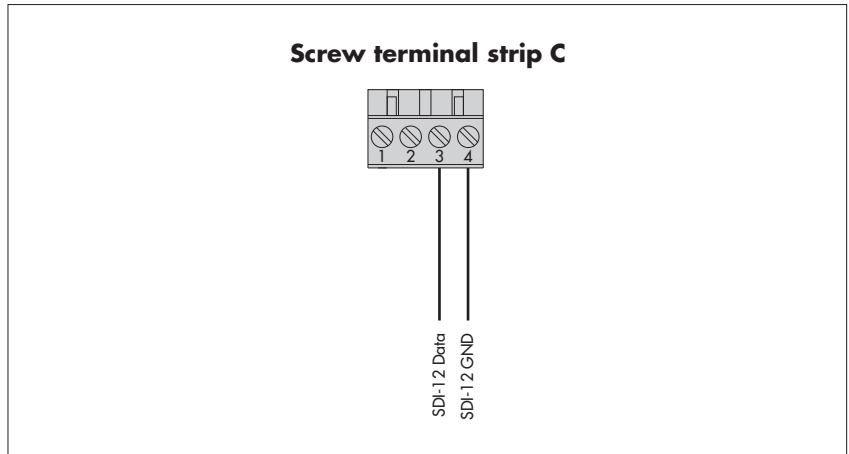

7.5 Connecting sensors having a pulse output

Fig. 11: Connecting sensors with pulse output to the OTT netDL unit (e.g. OTT Pluvio precipitation sensor or OTT Parsivel Present Weather Sensor).

The OTT netDL 500 unit has two (D 1-2, D 3-4) and the OTT netDL 1000 unit has four (D 1-2, D 3-4, E 1-2, E 3-4) pulse inputs that are independent from each other.

Further information can be found in the operating instructions of the respective sensor.

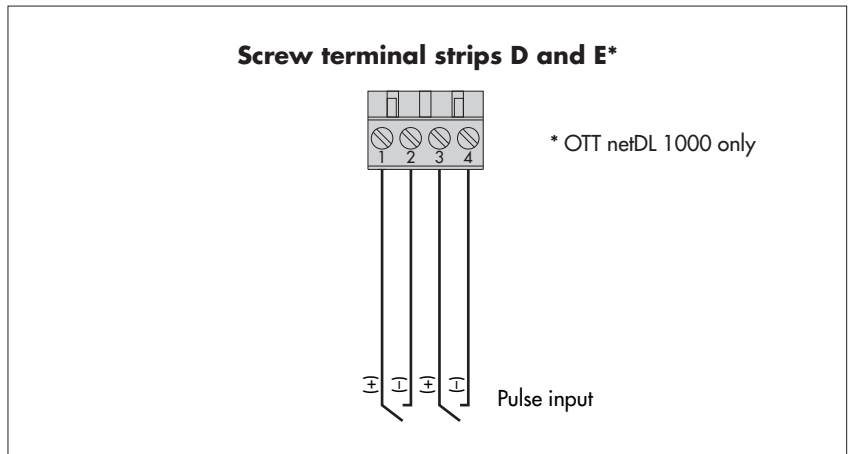

7.6 Connecting equipment having a status output

Fig. 12: Connecting devices to the OTT netDL unit that have a status output (e.g. door contact).

The OTT netDL 500 unit has two (D 1-2, D 3-4) and the OTT netDL 1000 unit has four (D 1-2, D 3-4, E 1-2, E 3-4) status inputs that are independent from each other.

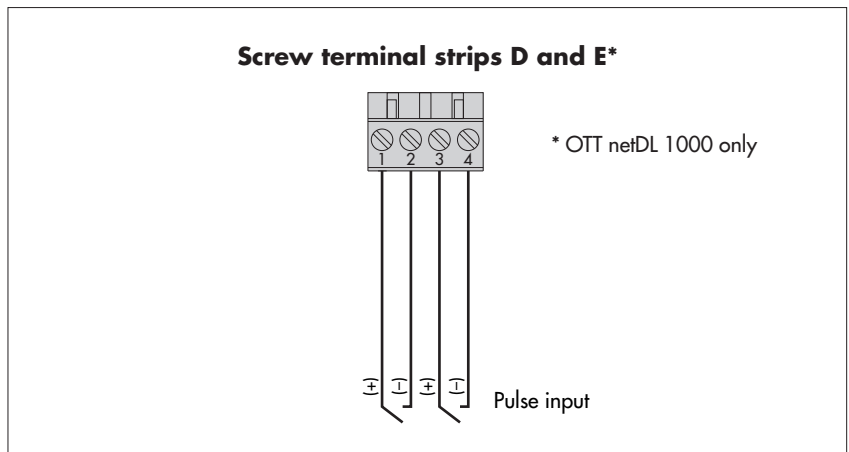

7.7 Connecting sensors having a voltage output *

Fig. 13: Connecting sensors to the OTT netDL unit that have a voltage output (e.g. OTT ODS 4 K).

Further information can be found in the operating instructions of the respective sensor.

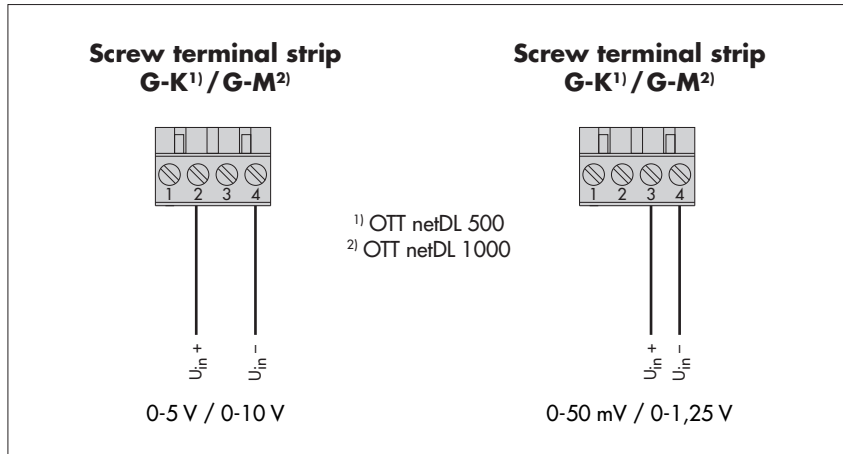

7.8 Connecting sensors having a current output *

Fig. 14: Connecting sensors to the OTT netDL unit that have a current output (e.g. OTT SE 200 shaft encoder or OTT PLS pressure probe).

Further information can be found in the operating instructions of the respective sensor.

Please note:

- For version 1: Do **not** supply the sensor externally!
- For version 2: **Additionally** supply the sensor externally!

With an OTT netDL supply voltage of higher than 24 V (28 V max.): A sensor connected in accordance with version 1 must be suitable for voltages higher than 24 V!

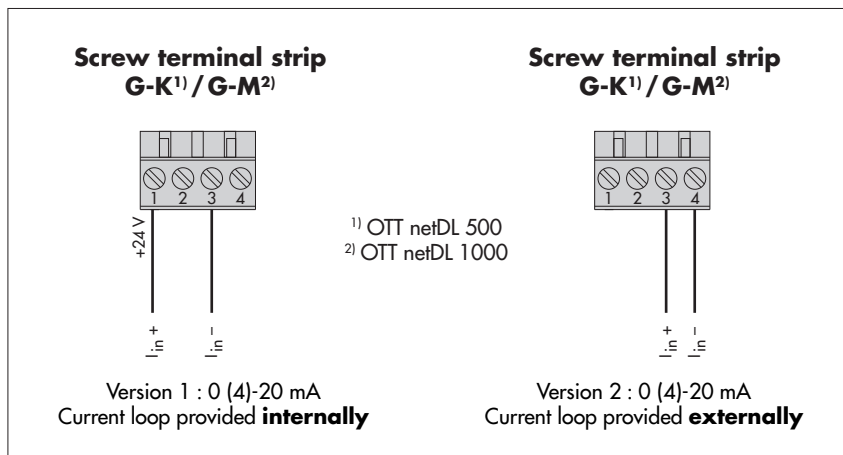

Please note: after each measurement the OTT netDL interrupts the current loop (due to secondary effects, there is still a constant rest current of approx. 9 mA). If other elements (e.g. display) belong to the current loop you have to close the current loop with an external resistance (R_{burden}) and configure the OTT net DL for a sensor with voltage output.

* OTT netDL with hardware expansion analog input card (refer to Chapter 2 "Ordering numbers and version code")

7.9 Connecting the Pt 100 temperature sensor *

Fig. 15: Connecting a Pt 100 temperature sensor to the OTT netDL unit.

Further information can be found in the operating instructions of the respective sensor.

Note: the colours of the connection cables depend on the used sensor. Colours indicated refer to specifications in the relevant standards.

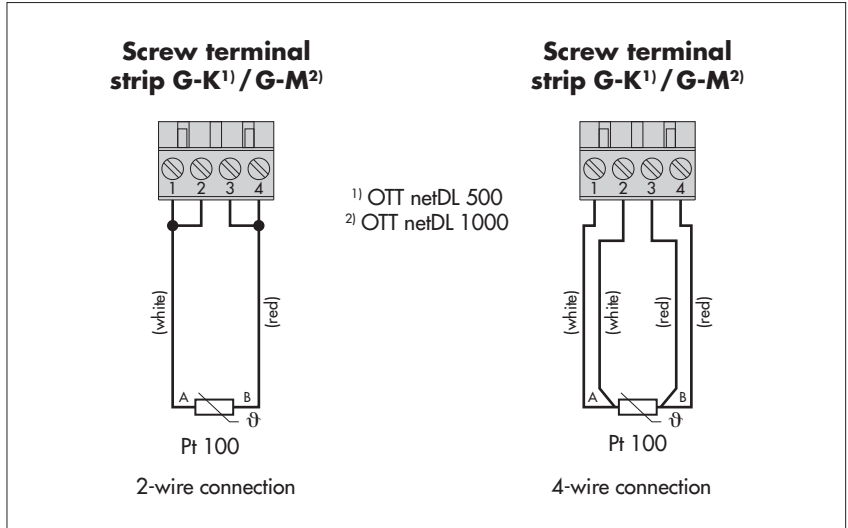

7.10 Connecting sensors having a potentiometer (5 kOhms) *

Fig. 16: Connecting sensors with potentiometer (5 kOhm typ.; max. 5.5 kOhm) to the OTT netDL unit.

The measurement value output is performed in values from 0 to 120 % of the nominal value of the potentiometer.

This requires a subsequent "2-point-scaling" of the measured value.

Further information can be found in the operating instructions of the respective sensor.

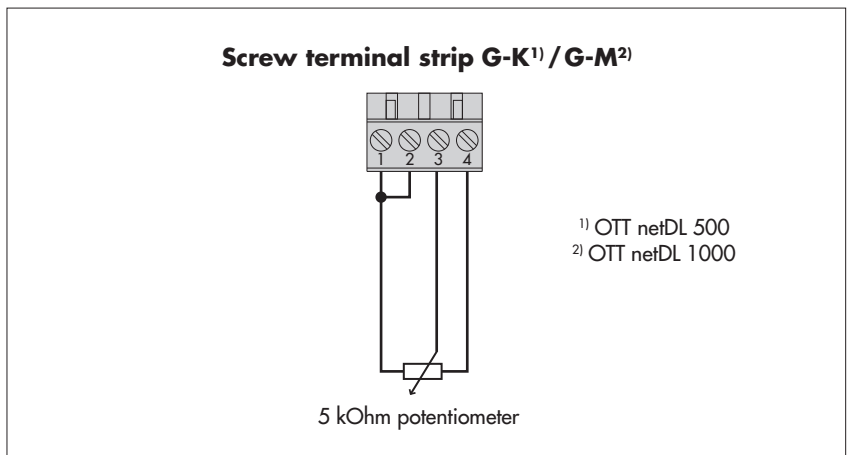

* OTT netDL with hardware expansion analog input card (refer to Chapter 2 "Ordering numbers and version code")

7.11 Connecting sensors having an RS-232 interface *

Fig. 17: Connecting sensors with RS-232 interface to the OTT netDL unit (e.g. OTT Nimbus bubble sensor).

A variety of sensors with RS-232 interface require a connection using only pins 2, 3, and 5.

Further information can be found in the operating instructions of the respective sensor.

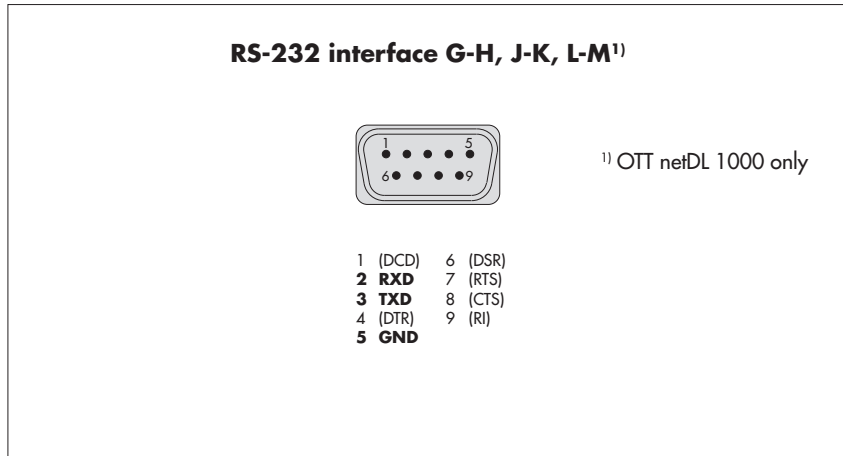

7.12 Connecting switching contacts

Fig. 18: Connecting the OTT netDL switching contacts.

Please note the maximum current capacity!

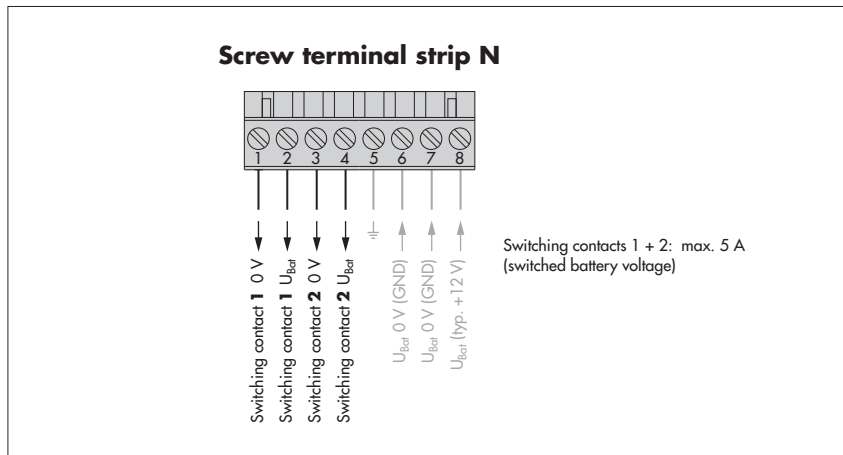

* OTT netDL with hardware expansion RS-232 input card
(refer to Chapter 2 "Ordering numbers and version code")

7.13 Connecting 4-20 mA outputs *

Fig. 19: Connecting the OTT netDL 4-20mA outputs.

Left: Connection schematic with **external** supply of the current loop.

Right: Connection diagram with **internal** supply of the current loop.

Make absolutely sure that the burden (R_{Burden}) in the current loop is correctly dimensioned!

Refer to Figure 21.

With the internally powered current loop, take into account that the actual supply voltage (U_{bat}) may be lower than the rated supply voltage.

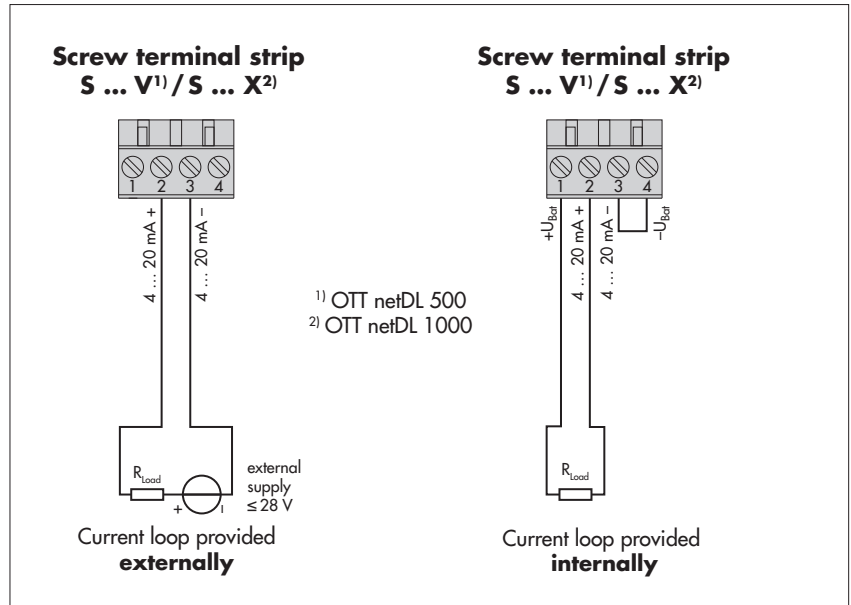
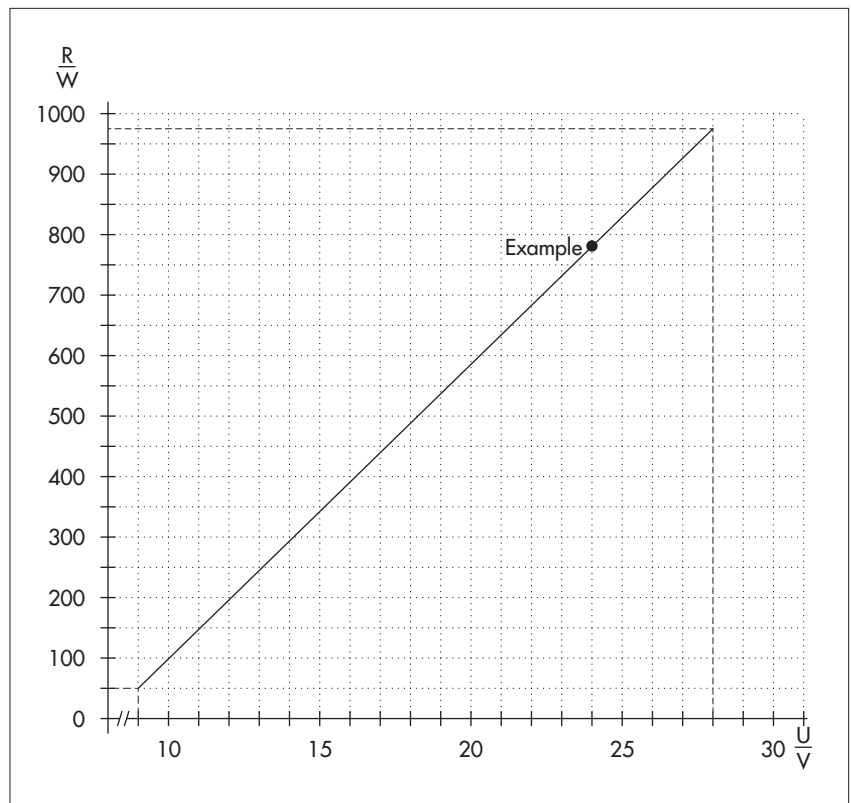

Fig. 20: Diagram for determining the maximum load resistance vs. supply voltage.

The load resistance (burden + ohmic resistance of the connection leads) connected to the OTT netDL unit must not exceed a specific maximum value. This value depends on the level of the supply voltage. When the load resistance is higher, the output current can no longer be evaluated. Smaller load resistances are allowed.

Example: 24 Volt supply voltage
→ max. load resistance 780 ohm. For a load resistance of up to 780 ohm, the OTT netDL unit provides output current based on the measured value.

Minimum supply voltage: 9 V
Maximum supply voltage: 28 V



* OTT netDL with hardware expansion "output card"
(refer to Chapter 2, "Order numbers and version code")

7.14 Connecting status outputs *

Fig. 21: Connecting the OTT netDL status outputs.

Please note the maximum current capacity!

The two outputs are galvanically isolated from each other and from the datalogger (optical couplers).

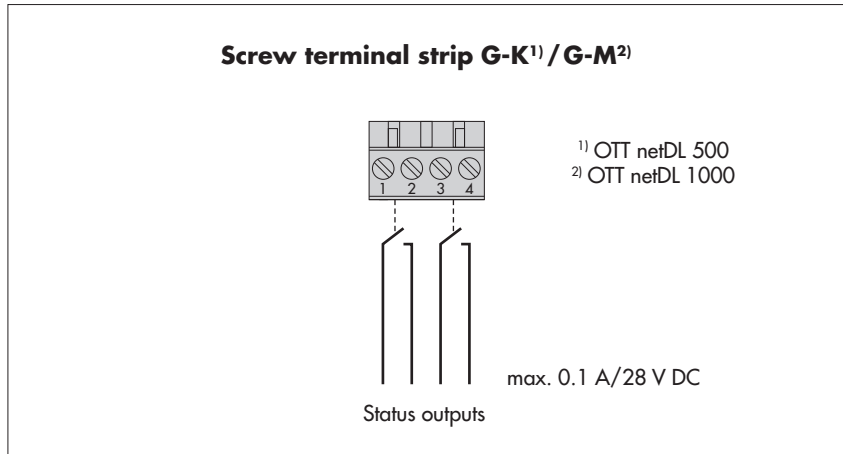

* OTT netDL with hardware expansion "output card"
(refer to Chapter 2 "Ordering numbers and version code")

7.15 Connecting the power supply to the OTT netDL unit

Fig. 22: Connecting voltage supply, e.g. to an OTT PCU 12 power control unit. The OTT PCU 12 is the OTT standard voltage supply.

Alternatively to PCU terminal 1 (load disconnect at a battery voltage of ≤ 7.5 V), terminal 2 can also be used (load disconnect at a battery voltage of < 10.5 V).

Please note: A battery must always be connected to the OTT PCU 12!

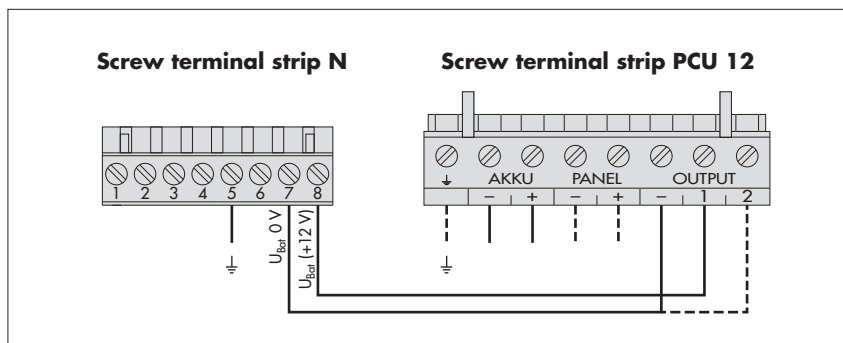

7.16 Connecting the radio antenna and inserting the SIM card (only device versions "B...", "C..." and "D...")

For the OTT netDL device versions "B...", "C..." and "D...", a radio antenna (accessory) is to be connected to the internal cellular modem and a SIM card obtained from the cellular radio provider to be inserted into the unit.

How to connect a radio antenna:

- Put the SMA plug of the radio antenna (accessory) onto the antenna socket and slightly tighten the lock nut by hand.
- Select an appropriate place for mounting the radio antenna (M16 center bolt, isolating washer and 23 mm across flat width nut).

Before mounting, please note the following:

- Minimum clearance between antenna and OTT netDL unit and people: 0.2 m;
- Do not mount the antenna inside a metal control cabinet.
- In case of poor cellular network coverage at the installation site, consider using a mast (including lightning protection equipment).
- If the accessory antenna is not used, the maximum antenna gain is 3.7 dBi.

Fig. 23: Connecting the radio antenna to the OTT netDL unit (figure shows the OTT netDL 500 unit, proceed the same way for the OTT netDL 1000 unit).

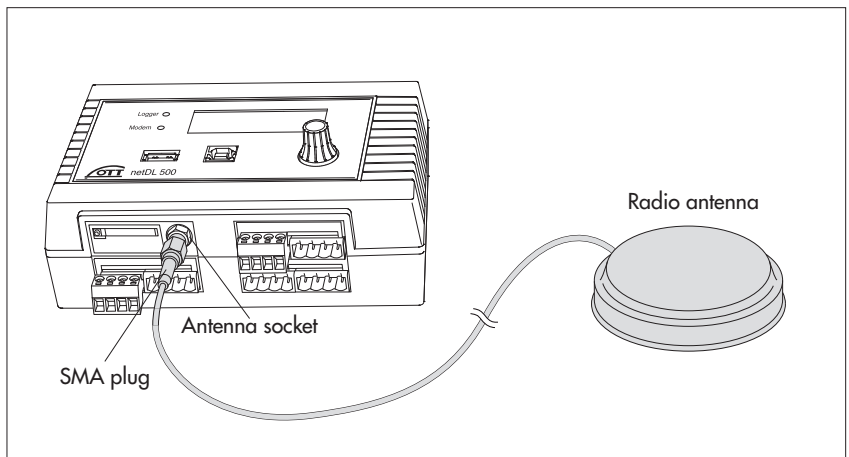

How to insert an SIM card:

- Using a sharp object (e. g. a ball pen or a pencil), press the yellow eject button.
- Completely pull out the SIM card holder.

Fig. 24: Inserting an SIM card into OTT netDL unit (figure shows the OTT netDL 500 unit, proceed the same way for the OTT netDL 1000 the unit).

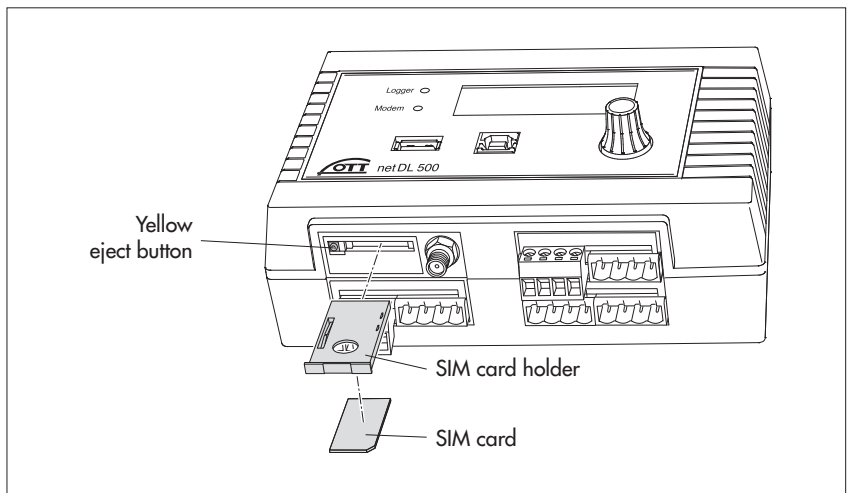

- Insert the SIM card into the SIM card holder.
While doing so, please note the following:
 - The gold-colored contacts of the SIM card are facing down. The beveled edge of the SIM card is located in the front on the right-hand side!
 - Do not touch the gold-colored contacts!
- With the SIM card inserted, completely push the SIM card holder into the OTT netDL unit, until it engages.

7.17 Connecting external communication equipment

If requested, a serial cable modem, a cellular modem, or a satellite communication unit can be connected to the OTT netDL unit.

- Connect the RS-232 interface of the OTT netDL unit to a modem/satellite communication unit using a commercially available modem connection cable (accessory).
- Optional: Connect the supply voltage of the modem using switching contacts 1 or 2 (screw terminal strip N 1-2 or N 3-4). (The modem is not permanently powered → reduces the current consumption of the station. The OTT netDL unit enables power to the modem at specified time windows and/or when data transfer is due.)

Note

- ▶ An external voice-enabled modem for the voice announcer is always to be connected to the COM 1 serial interface (refer to Fig. 4). When the COM 1 serial interface is configured for the voice announcer, you cannot use this interface for establishing a communication link.

Fig. 25: Modem connection cable.

(9-pin Sub-D socket to 9-pin Sub-D connector; PIN 2 and PIN 3 each directly connected; for position(s) of the RS-232 interface(s) on the OTT netDL unit, refer to Fig. 4; for pin assignment of the RS-232 interface, refer to Fig. 7).

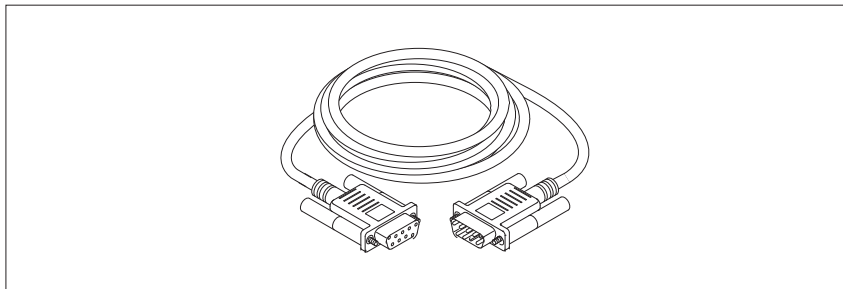
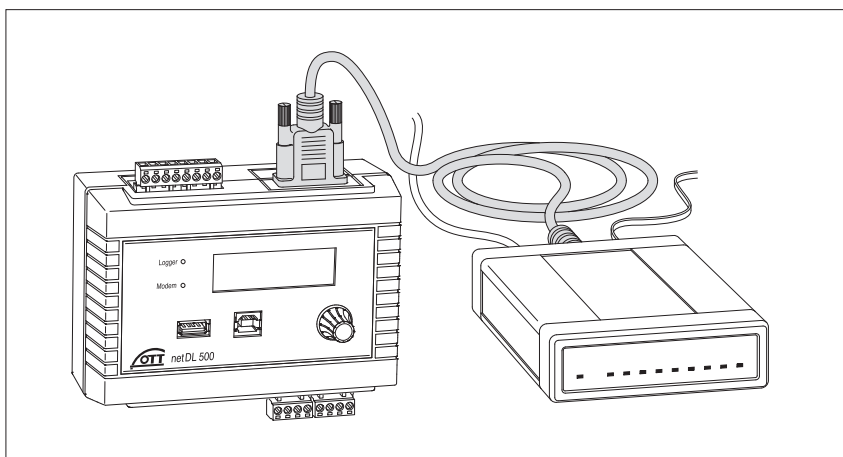

Fig. 26: Connecting serial modem to the OTT netDL unit via modem connection cable (figure shows the OTT netDL 500 unit, proceed the same way for the OTT netDL 1000 the unit).



7.18 Connecting an Ethernet LAN or DSL router

Through a built-in Ethernet interface, the OTT netDL 1000 unit may be connected to an Ethernet LAN (web access through a Local Area Network) or to a DSL router (web access using a modem connected to a digital subscriber line (DSL)).

- Connect the built-in Ethernet interface to an Ethernet LAN or DSL router using an RJ-45 patch cable (1-to-1 pin assignment from CAT 3 on).

Fig. 27: Connecting Ethernet LAN or DSL router to the OTT netDL 1000. The two LEDs indicate the status of the Ethernet interface; refer to Chapter 10

Max. length of RJ-45 patch cable (Cat 5/6): 100 m!

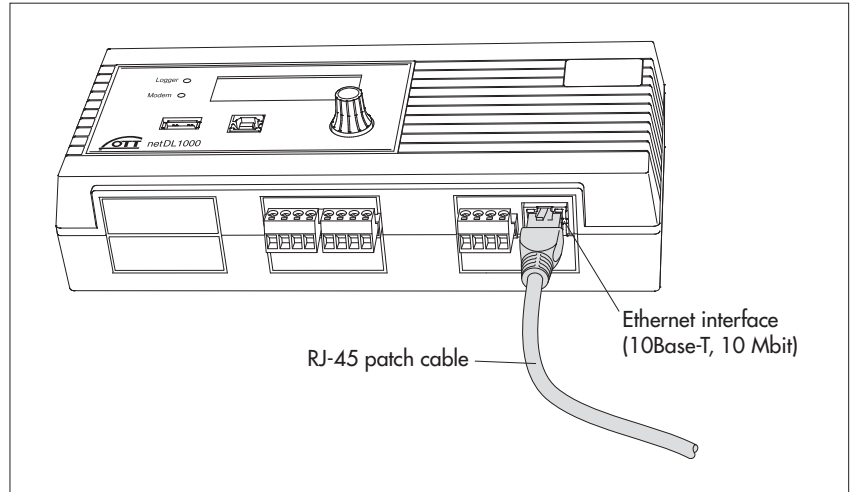

7.19 IP coupling

It is possible to connect two (or more) OTT netDL 1000 via the integrated Ethernet-interface. This requires the software expansion "External IP devices". In this case communication and data transmission is done via internet protocol over a Local or Wide Area Network (LAN/WAN). This enables decentralized monitoring of measured data at sites which cover a large area and centralised data processing by an OTT netDL 1000.

IP coupling in one LAN

Fig. 28: IP coupling of two OTT netDL 1000 in one LAN.

Max. length RJ-45 patch cable (Cat 5/6): 100 m!

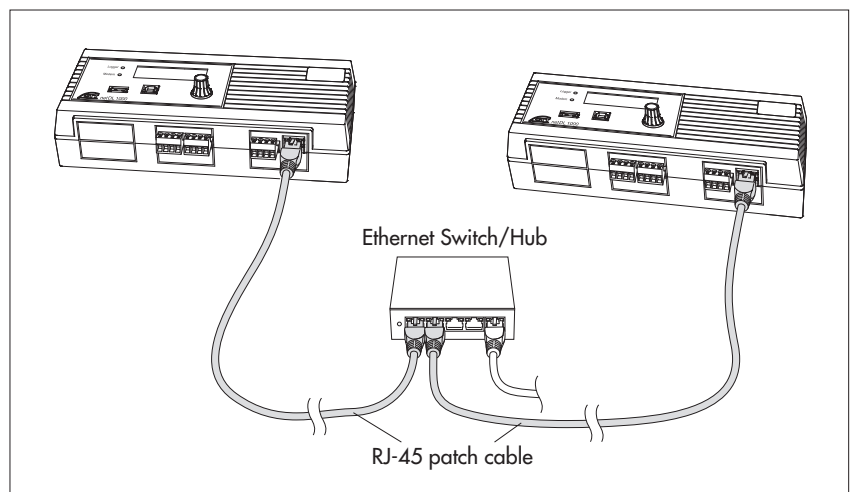

- Connect the integrated Ethernet interface via a RJ-45 patch cable (assignment 1:1; from CAT 3) of each OTT netDL 1000 with an Ethernet switch or hub.

IP coupling in one WAN

Fig. 29: IP coupling of two OTT netDL 1000 in one WAN.

Max. length RJ-45 patch cable (Cat 5/6): 100 m!

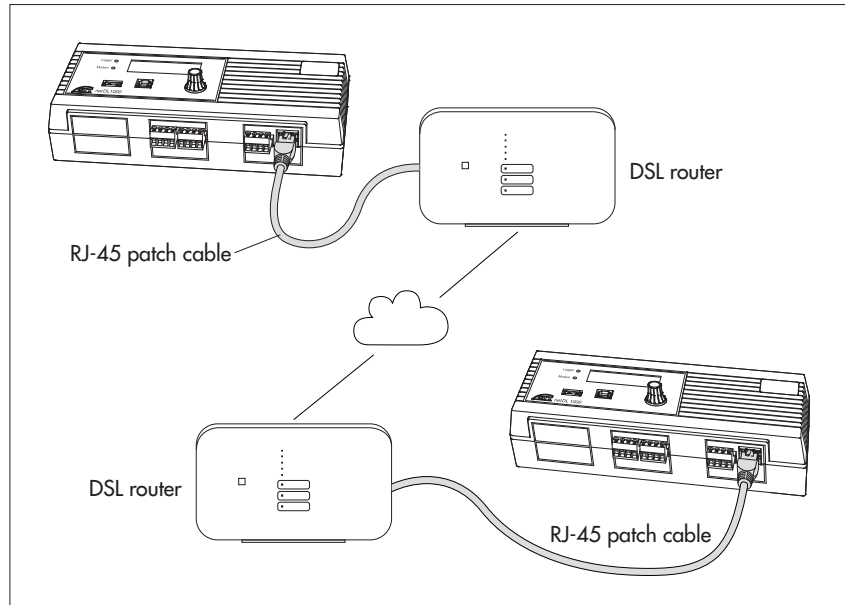

- Connect the integrated Ethernet interface via a RJ-45 patch cable (assignment 1:1; from CAT 3) of each OTT netDL 1000 with a DSL router (or alternative Internet access).

Special case: direct IP coupling

It is not recommended to make a direct IP coupling of two OTT netDL 1000 though it is technically possible!

- Connect the integrated Ethernet interfaces of the OTT netDL 1000 via a RJ-45 cross cable (crossed wires; from CAT 3) directly.

7.20 Connecting the USB device interface

For setting the OTT netDL operating parameters or for retrieving measured data from an OTT netDL unit, you must establish a temporary communication link to a PC. You may also establish this communication link using a USB connection cable and the USB device interface of the OTT netDL unit (refer to Chapter 8.2).

- Connect the USB cable to a USB socket of the PC (USB connector type A).
- Connect the USB cable to the USB device interface of the OTT netDL unit (USB connector type B).

Fig. 30: Connecting the USB cable to the OTT netDL unit.

(Figure shows the OTT netDL 1000 unit; proceed the same way for the OTT netDL 500 unit.)

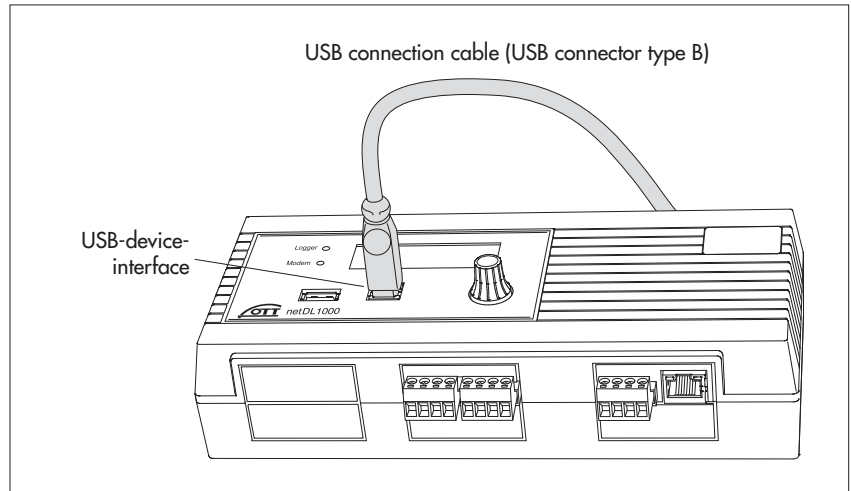

7.21 Connecting the USB host interface

OTT netDL provides the possibility to connect a USB stick to the USB host interface. This allows for a variety of functions:

- ▶ Read data (measured values), event log (events), device configuration and diagnosis information into USB stick
- ▶ Updating of firmware and device configuration via USB stick

For more information regarding the use of a USB stick with the OTT netDL, see Chapter 9.10.

- Connect the USB stick to the USB host interface of the OTT netDL (USB connector type A).

Fig. 31: connecting USB stick to USB host-interface of OTT netDL.

(Picture shows OTT netDL 1000; proceed in the same way with OTT netDL 500.)

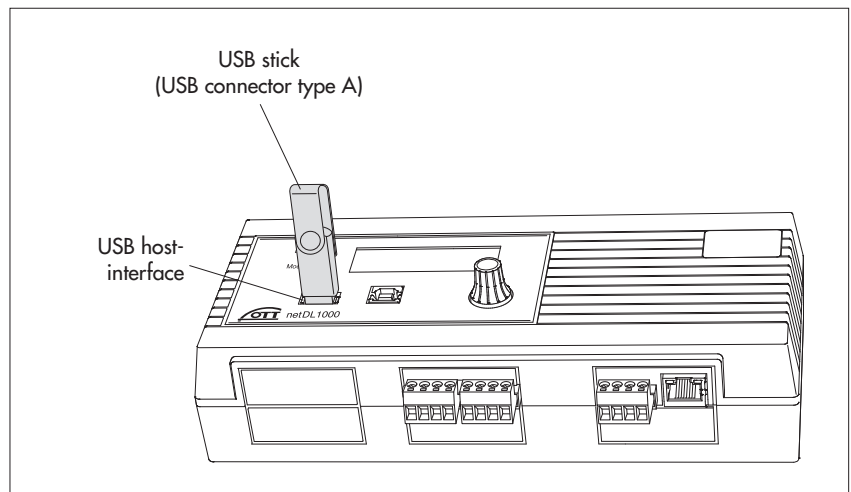

7.22 Connecting the IP camera

It is possible to connect an IP camera via the integrated Ethernet interface of the OTT netDL, for example to get a visual overview of the situation at a measuring site. This requires the software expansion "External IP devices".

Power supply is provided via separate connection cable

- Connect the IP camera to the OTT netDL as shown in Fig. 32. Connection to the Ethernet interface requires a RJ-45 cross cable (crossed wires; from CAT 3), power supply of the camera requires a two-wire connection cable (adjust wire cross-section to cable length); power consumption of the camera which OTT offers as accessory: max. 6 W).

Fig. 32: Connecting the IP camera to the OTT netDL 1000 with a separate connection cable for the power supply.

The picture shows power supply of the camera via the separate connection cable which is connected to terminal "N" (switch contact 1 or 2) (switched power supply of the camera; max. 12 V!).

Note: "Lag time" of the switch contact must be set to min. 40 seconds!

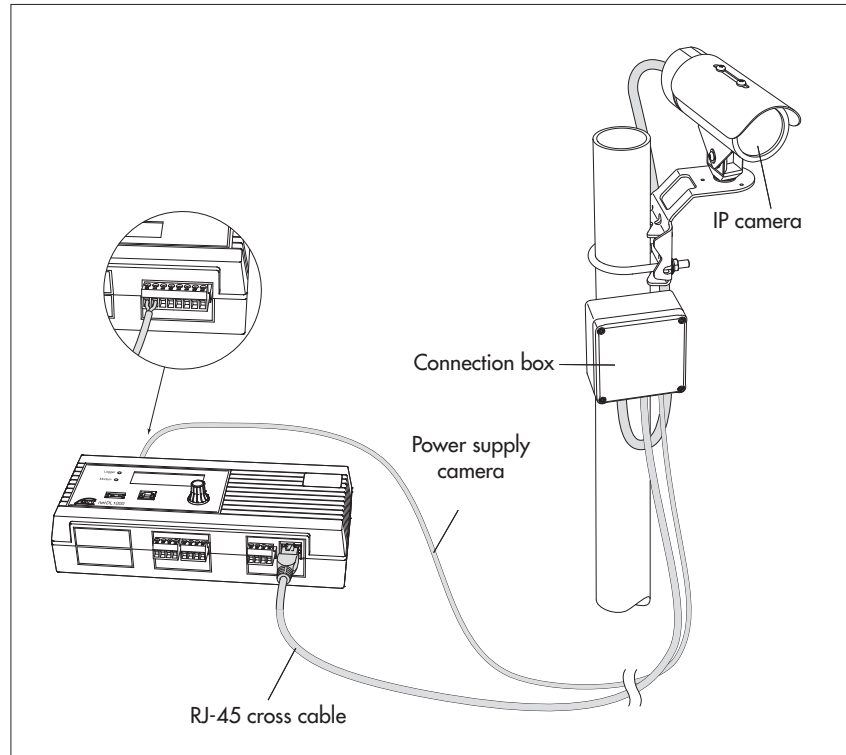

Power supply via "Power over Ethernet (PoE)*"

- Connect the IP camera as shown in Fig. 33 to the OTT netDL. Connection of the camera and the OTT netDL to the PoE injector via a RJ-45 patch cable (wiring 1:1; from CAT 3). Instead of a PoE injector it is also possible to use a PoE-ready Ethernet switch.

* Power supply via Ethernet cable

Fig. 33: Connecting the IP camera to the OTT netDL 1000 via "Power over Ethernet".

The picture shows power supply of the PoE injectors via terminal "N" (switch contact 1 or 2) of the OTT netDL (switched power supply).

Note: "Lag time" of the switch contact must be set to min. 40 seconds!

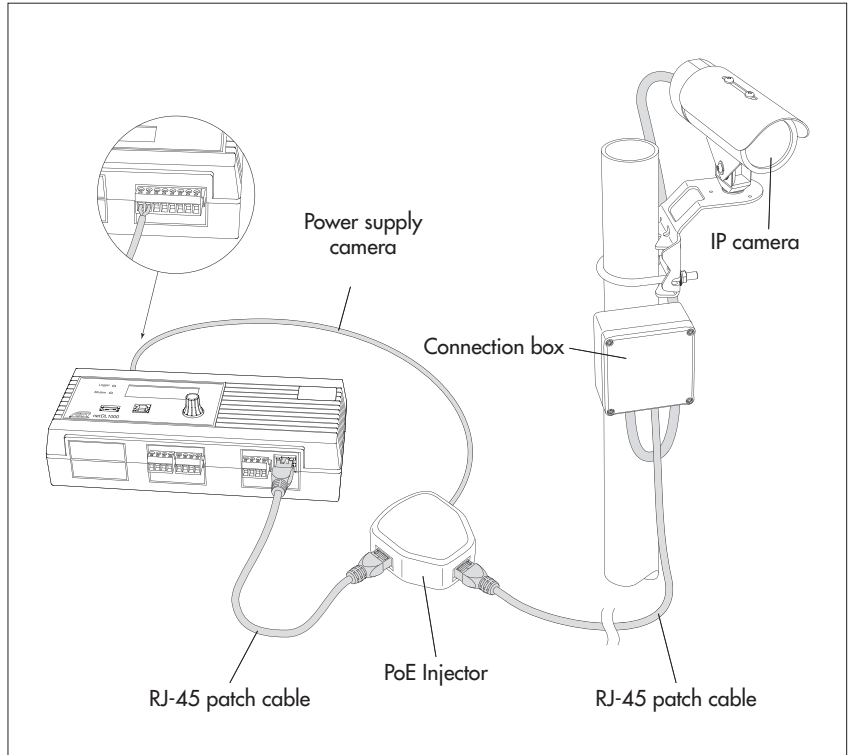

7.23 Connecting the satellite transmitter

The combination with a satellite transmitter SUTRON SL3-XMTR-1 enables data transmission which is time synchronised by GPS via the geostationary weather satellites GOES and Meteosat. Together with the sensors connected to the data-logger, this constitutes the so-called "Data Collection Platform (DCP)".

- Connect the satellite transmitter SUTRON SL3-XMTR-1 and the accessories to the OTT netDL as shown in Fig. 34. Furthermore, please follow the operating instructions of the satellite transmitter!

A GPS antenna and the connection cable satellite transmitter/OTT netDL are included in the scope of delivery of the satellite transmitter SUTRON SL3-XMTR-1.

Please note: to use a DCP you will need an authorization issued by the operator organizations EUMETSAT or NOAA/NESDIS as well as the assigned transmission parameters and transmission times.

Data transmissions are not permitted

- if you do not have an authorization;
- with unauthorized transmission parameters/transmission times!

Fig. 34 (on the right): connection example of satellite transmitter SUTRON SL3-XMTR-1 to OTT netDL 500 or OTT netDL 1000 (inside a metal control cabinet).

In this example the overvoltage protection serves also as bulk head connector for the antenna connection cable. The GPS antenna must be placed outside the control cabinet!

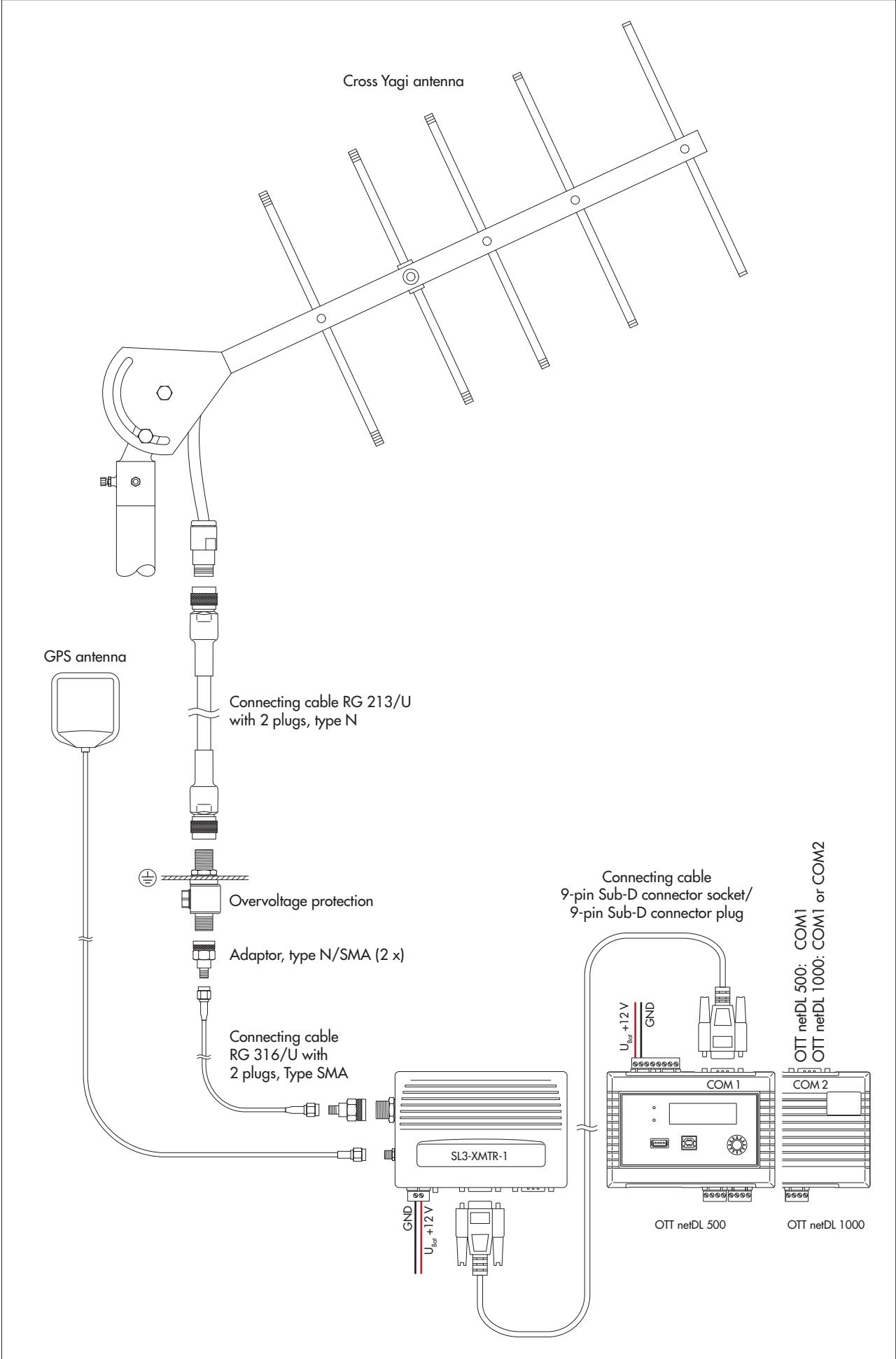

8 Setting OTT netDL operating parameters

To set the OTT netDL operating parameters, you need the "OTT Data Logger Operating Program" (WBSLA0.exe) PC software. This set-up file of this operating program is found on the USB stick "OTT Hydromet Software" (accessory). Alternatively, you will find it on the website "www.ott.com/resources" for download (free of charge).

Hardware and software requirements: Up-to-date standard PC with RS-232 interface or USB interface (desktop/tower or notebook design); operating system: Windows Vista™ or later.

Additional (accessories):

- ▶ OTT netDL/PC data transfer cable (see accessories; null modem cable)
- ▶ USB connection cable
- ▶ RJ-45 crossover cable for direct connection between PC and OTT netDL
- ▶ RJ-45 patch cable for connection via switch or router

8.1 Installing the OTT Data Logger Operating Program

How to install the OTT Data Logger Operating Program

- Start the set-up file "Setup_DataloggerOP_Vxxxx_DE.exe" (on USB stick or download from website; see above).
- Follow the installation instructions on the screen.

8.2 Establishing the PC/OTT netDL communication link (on site)

In the Chapters 8 and 11 to 19, the establishment of a communication link between the OTT netDL and a PC is a pre-requisite for the following steps. The following description illustrates the setup of this communication link and its variations.

How to set up a communication link using a data transfer cable

- Connect the data transfer cable (9-pin Sub-D socket to 9-pin Sub-D socket; pins 2 and 3 each crossed) to a serial interface of the PC (e.g. COM 1).
- Connect the data transfer cable to the serial communication interface of the OTT netDL (COM 1 or COM 2 (OTT netDL 1000 only); refer to Fig. 4).
- Start the OTT netDL operating program.
- In the OTT netDL operating program, select the serial interface (COM1, COM2) and transmission speed (typically: 115200 bps) used in the "RS232/V.24" communication path.

Note

- ▶ When the COM 1 serial interface is configured for the voice announcer, you cannot use this interface for establishing a communication link.

How to set up a communication link using a USB connection cable

Requirements: USB interface drivers are installed (see below).

- Connect the USB connection cable to a USB socket of the PC (USB connector type A).
- Connect the USB connection cable to the USB device interface of the OTT netDL (USB connector type B; refer to Fig. 29).
- Start the operating program.
- In the operating program, select the "USB" communication path.

If required: Installing the USB interface driver

For establishing a communication link over the USB interface, the PC requires a dedicated USB interface driver (on USB stick or download form website; see earlier section). This USB interface driver must be installed, when the communication link is established for the first time.

You may use the USB interface driver on any current standard PC that is fitted with a USB interface and on which a Microsoft Windows Vista™ or higher operating system is run.

The procedure described here is based on the Microsoft Windows Vista™ operating system. With minor changes, it applies to the other Windows operating system versions as well.

How to install the USB interface driver:

- Log on to the PC with administrator rights.
- Connect the OTT netDL unit to a USB interface of the PC → the PC detects the new hardware and displays the message*: "Found New Hardware – OTT netDL" → the "Found New Hardware Wizard" opens.
- Select "No, not this time".
- Select "Next".
- Select "Install from a list or specific location (Advanced)".
- Select "Next".
- Insert USB stick "OTT Hydromet Software" into the USB interface of the PC.
- Select "Search for the best driver in these locations" and "Search removable media (CD-ROM, ...)". Alternatively (if you have downloaded the driver from the Internet) select the driver manually.
- Select "Next".
- The wizard will install the USB interface driver onto the PC.
- After completion of the installation process, the following message will appear: "The wizard has finished installing the software for: OTT netDL".
- Select "Next". Now a communication link via the USB interface may be established.

* In the notification area of the taskbar

How to set up a communication link using an RJ-45 crossover cable

The OTT netDL must be configured accordingly (IP-address, ...); see online help of the operating program.

- Connect the RJ-45 crossover cable to an Ethernet interface of the PC.
- Connect the RJ-45 crossover cable to the Ethernet interface of the OTT netDL unit.
- Start the operating program.
- In the operating program, select the "IP Connection" communication path.

Notes

- ▶ Change the language for the operating program as required:
Press the F3 function key (multiple times) until the required language appears.
- ▶ For more information on setting up a communication link (also from remote), please refer to the online help of the operating program.



Please note: With a nearly full data memory in the OTT netDL unit, it may take a few minutes after an interruption of the operating voltage until communication is possible again!

8.3 Introduction: Setting OTT netDL operating parameters

How to set the OTT netDL operating parameters using a PC:

- Establish the PC/OTT netDL communication link (refer to Chapter 8.2).
- If you have not already done so: Connect the OTT netDL unit to operating voltage. After a few seconds, the OTT netDL unit is ready to use (the LCD display shows various messages and then turns off).
- Start the operating program.
- In the "Device" menu, select the "netDL 500/1000" option.
- Read the current OTT netDL configuration into the operating program: In the "netDL 500/1000" menu, select the "Read" option or click the "Read" button*
→ The operating program reads the current (factory default) OTT netDL configuration and displays it in the operating program main window:

Fig. 35 Main window of the operating program.

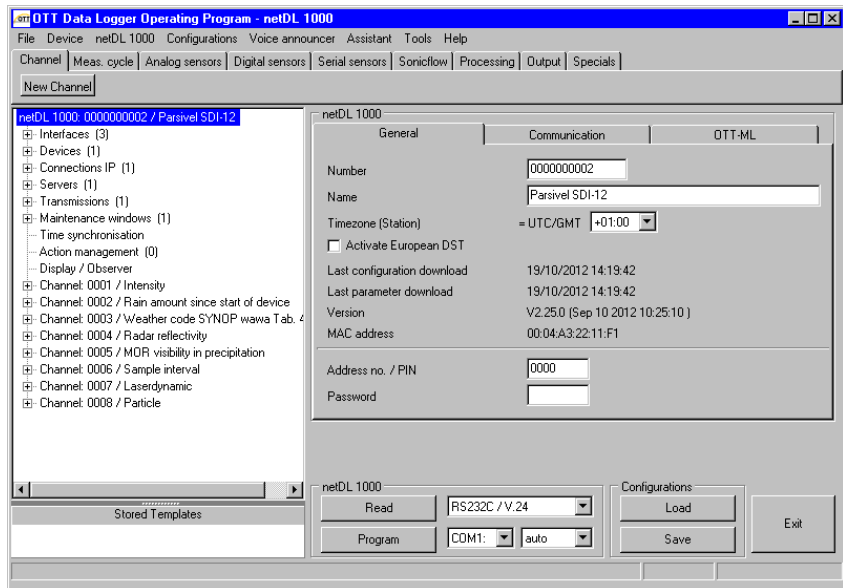

- Now make the adjustments according to your specific requirements:
 - Master data
 - Interfaces
 - Devices
 - Connections IP
 - Server
 - Transmissions
 - Maintenance window
 - Time synchronization
 - Action management
 - Display/Observer
 - Channel-related function
 - Voice announcer (optional)
- Click on the "Program" button.
- Acknowledge the message "Warning: Reset OTT netDL and delete data memory additionally?" by selecting "Yes" (recommended for initial installations). The OTT netDL is now completely configured and parametrized and starts processing the measuring and communicating jobs.

For detailed information on how to set the OTT netDL operating parameters, please refer to the online help of the operating program.

* When the communication link uses a USB cable and several OTT netDL units are connected to the PC at the same time: First select the desired unit in the selection window and then select "OK".

9 Operating/configuring the OTT netDL unit on site

For operating the unit on site, OTT netDL is equipped with a backlit LCD display (4 rows x 20 characters) and a "jog shuttle". The jog shuttle is a special operating button that can be rotated and pressed.

The following functions can be called with the jog shuttle:

- ▶ Determine and display instantaneous values (Observer function)
 - with input of a check value (manual value),
 - without input of a check value (manual value).
- ▶ Enter observer texts (extended Observer function)
- ▶ Scale instantaneous values/stored values (set offset)
- ▶ Display/set date and time
- ▶ Enter manual values into a manual sensor
- ▶ Display information on transmissions
- ▶ Display information on connections
- ▶ Display system information
- ▶ Start voice announcer (optional)
- ▶ With an USB stick connected to the OTT netDL:
 - Read data (measured values), event log (events), device configuration, diagnosis information;
 - Update firmware, device configuration

Meaning of the function symbols on the LCD display

- ! "Enter observer text" / "Enter manual value into manual sensor"
- "continue"
- ↵ "enter"
- ⏪ "cancel" / "exit" / "back"

9.1 Detecting and displaying instantaneous values (Observer function)

Requirements

- ▶ The configuration of a channel that is to determine and display an instantaneous value must include the "Instantaneous value" function block (refer to online help).
- ▶ If additional check values are to be entered, the "Observer manual input" option in the "Instantaneous value" (OTT netDL Firmware 2.11.0 and earlier: "Display/Observer" function block) function block must be activated (refer to online help).

How to determine and display instantaneous values without entering a check value (manual value):

- Press jog shuttle twice. (Between the first and second presses, the LCD display shows the OTT netDL firmware version.) The OTT netDL unit activates the LCD display and shows the selection menu (if password protection for the LCD display is active → enter the four-digit password first; refer to online help).
- Press jog shuttle (Observer). The LCD display shows the station name, the station number, the current time and, after 2 seconds, the level of the voltage supply.
- Press jog shuttle (→). The LCD display shows the screw terminal strip used, the sensor name/number and the instantaneous value of the first channel (sensor).
- To show the instantaneous values of additional channels, press jog shuttle once each time (→). After the instantaneous value of the last channel has been shown, the LCD display shows the instantaneous value of the first channel again.
- To end the display of the instantaneous values, rotate jog shuttle to ⏪ and press (max. twice); then rotate jog shuttle to End and press. If the jog shuttle is not used for three minutes, the LCD display shuts off automatically.

How to determine and display instantaneous values when entering a check value (manual value):

- Press jog shuttle twice. (Between the first and second presses, the LCD display shows the OTT netDL firmware version.) The OTT netDL unit activates the LCD display and shows the selection menu (if password protection for the LCD display is active → enter the four-digit password first; refer to online help).
- Press jog shuttle (Observer). The LCD display shows the station name, the station number, the current time and, after 2 seconds, the level of the voltage supply.
- Press jog shuttle (→). The LCD display shows the screw terminal strip used and the sensor name/number as well as the instantaneous value of the first channel (sensor). If the "Suppress display of instantaneous value before input" option in the "Instantaneous value" (OTT netDL Firmware 2.11.0 and earlier: "Display/Observer" function block) function block is activated, the OTT netDL unit suppresses the instantaneous value by means of asterisks.
- Rotate jog shuttle to ←.
- Press jog shuttle (←). The check value is now to be entered by character from right to left. The character to be changed in each case is shown inverted (white on black background) and flashing.
- Rotate jog shuttle until required character appears.
- Press jog shuttle to jump to the next character position, etc.
- Confirm the entry: Press jog shuttle (←). (Cancel: Rotate jog shuttle to ← and press). The OTT netDL unit now determines the current instantaneous value of the first channel (sensor) and shows it on the LCD display (during measurement, the LCD display shows the Observer message).
- To enter the check value and show the instantaneous values of additional channels, rotate jog shuttle to → each and press. Then return to step 4 and repeat. After the instantaneous value of the last channel has been shown, the LCD display shows the instantaneous value of the first channel again (it is not necessary to enter a check value again).
- To end the display of the instantaneous values, rotate jog shuttle to ← and press (max. twice); then rotate jog shuttle to End and press. If the jog shuttle is not used for three minutes, the LCD display shuts off automatically.

Notes

- ▶ The "Observer" function initiates an instantaneous value measurement. Until this measurement is complete, the display refers to the last stored value (or the instantaneous value last displayed, whichever is the most recent). On the display, this is identified with an "ε" after the channel number (sensor number). After completing the measurement, the new measured value appears without additional identification.
- ▶ The OTT netDL stores each call of the "Observer" function in the info channel together with date and time. After "Read" and "Accept", this information can be displayed in the evaluation window of a sensor in the Hydras 3 application software using the "Info Data | Station | Display" option (observer registration general).
- ▶ If the "Observer Manual input" option in the "Display/Observer" function block is activated, the OTT netDL also stores the check value entered as well as the currently measured instantaneous value (if other channels are configured, this also applies to the instantaneous values of these channels). These values can be displayed in the evaluation window of a sensor after being "Read" and "Accept" to the Hydras 3 application software using the "Info Data | Sensor | Display" function (observer registration with check value).

9.2 Entering observer texts (extended Observer function)

Requirements

- ▶ The "Extended observer (store and transmit number)" option in the "Display/Observer" function block is activated (refer to online help).
- ▶ In the "Display/Observer" function block, observer texts are stored (refer to online help).

How to enter observer texts for the station:

- Press jog shuttle twice. (Between the first and second presses, the LCD display shows the OTT netDL firmware version.) The OTT netDL activates the LCD display and shows the selection menu (if password protection for the LCD display is enabled → first enter the four-digit password; refer to online help).
- Press jog shuttle (Observer). The LCD display shows the station name, the station number, the current time and, after 2 seconds, the level of the voltage supply.

... For the measurement site:

- Rotate jog shuttle to !.
- Press jog shuttle in order to begin the entry of the observer texts.
- When a "Manual sensor" is present in the configuration of the OTT net DL unit (the LCD first shows a selection window): press the jog shuttle (Observer).
- Rotate jog shuttle until the required number/text appears and then press. (The numbers are not necessarily sorted in ascending order. The row numbers of the table entries of the observer texts are decisive; refer to online help). By selecting the number 0000, freely editable texts can be entered (see below).
- Confirm the entry: Press jog shuttle (+). (Cancel: Rotate jog shuttle to ← and press.)
- Finish entering observer text: ("Manual sensor" present: first rotate jog shuttle to the Exit position and press) rotate jog shuttle to ← and press; then rotate jog shuttle to the Exit position and press. If the jog shuttle is not used for three minutes, the LCD display shuts off automatically.

... For a channel (sensor):

- Press jog shuttle (→). The LCD display shows the screw terminal strip used, the sensor name/number as well as the instantaneous value of the first channel (sensor).
- Change to the next channel if required: Press (several times) jog shuttle (→). After the last channel has been shown, the LCD display shows the first channel again.
- Rotate jog shuttle to the ! position.
- Press jog shuttle to begin entering the observer texts.
- Rotate jog shuttle until the required number/text appears and then press. (The numbers are not necessarily sorted in ascending order. The row numbers of the table entries of the observer texts are decisive; refer to online help). By selecting the number 0000, freely editable texts can be entered (see below).
- Confirm the entry: Press jog shuttle (+). (Cancel: Rotate jog shuttle to ← and press.)
- Finish entering observer text: rotate jog shuttle to ← and press (twice); then rotate jog shuttle to Exit position and press. If the jog shuttle is not used for three minutes, the LCD display shuts off automatically.

How to enter freely editable text:

- Select number 0000 (see above).
- Press jog shuttle (←) to begin with text entry. The text is now entered character by character from left to right. Each character to be entered is shown inverted (white on black background) and flashing.
- Rotate jog shuttle until required alphanumeric character appears.
- Press jog shuttle to confirm the character and to move to the next position
- Press jog shuttle
- Rotate the jog shuttle until the next desired character appears etc.
- Eingabe bestätigen: Rotate jog shuttle to ← and press.

9.3 Scaling instantaneous values/stored values (set offset)

Prerequisites

- ▶ The configuration of a channel that is to be scaled must include the "Instantaneous value" function block (refer to online help).
- ▶ The "Observer manual input" and "Calculate manual input value with scaling" options must be enabled in the "Instantaneous value" function block (for OTT netDL Firmware 2.11.0 and earlier: "Display/Observer" function block), (refer to online help).
- ▶ Changing an instantaneous value in the display is only available for channels for which the "Scaling $y=ax + b$ " or "2-point scaling" function block has been created during configuration (refer to online help). Changing an instantaneous value will affect the scale of that channel (offset). The OTT netDL unit records instantaneous value changes in the "Info channel" of a sensor (evaluation using Hydras 3).

How to change (scale) an instantaneous value:

- Press jog shuttle twice. (Between the first and second press, the LCD display shows the OTT netDL firmware version.) The OTT netDL unit activates the LCD display and shows the selection menu (if password protection for the LCD display is enabled → enter the four-digit password first; refer to online help).
- Press jog shuttle (Observer). The LCD display shows the station name, the station number, the current time, and after 2 seconds the level of the voltage supply.
- Press jog shuttle (→). The LCD display shows the screw terminal strip used, the sensor name/number as well as the instantaneous value of the first channel (sensor). When the "Suppress display of instantaneous value before input" option in function block "Instantaneous value" is enabled (for OTT netDL Firmware 2.11.0 and earlier: "Display/Observer" function block), the OTT netDL first suppresses the instantaneous value by means of asterisks.
- Rotate jog shuttle to ←.
- Press jog shuttle (←). The new value is now entered number by number from right to left. The number to be changed in each case is shown inverted (white on black background) and flashing.
- Rotate jog shuttle until required number appears.
- Press jog shuttle to move to the next number position etc.
- Confirm entry: Press jog shuttle (←). (Cancel: Rotate jog shuttle to ← and press). The OTT netDL unit now determines the scaled instantaneous value of the first channel (sensor) and displays this value on the LCD display (during measurement, the LCD display shows the *Parameter changed* message).
- To scale additional channels, rotate jog shuttle to → and press for each channel. Then return to step 4 and repeat. After the instantaneous value of the last channel has been shown, the LCD display shows the instantaneous value of the first channel again.
- Finish displaying instantaneous values, rotate jog shuttle to ← and press (max. twice); then rotate jog shuttle to the *Exit* position and press. When the jog shuttle is not used for three minutes, the LCD display shuts off automatically.

9.4 Displaying/setting date and time

How to set the date and time:

- Press jog shuttle twice. (Between the first and second presses, the LCD display shows the OTT netDL firmware version.) The OTT netDL unit activates the LCD display and shows the selection menu (if password protection for the LCD display is active → enter the four-digit password first; refer to online help).
- Rotate jog shuttle to **Settings** and press.
- Press jog shuttle (**Date/Time**) → the OTT netDL unit shows the current time and date.

How to set the date and time:

- Press jog shuttle (**←**).
- Change number: Rotate jog shuttle.
- Jump one number to the right : Press jog shuttle. After moving to the seconds, the OTT netDL shows **←** and **→**.
- Set date/time (store): Press jog shuttle (**←**). (Cancel: rotate jog shuttle to **↵** and press.)
- Finish display: Rotate jog shuttle to **↵** and press; then rotate jog shuttle three times to the **Exit** position and press. When the jog shuttle is not used for three minutes, the LCD display shuts off automatically

Alternatively, the date and time can be set via the operating program: "OTT netDL menu, "Date / time" function.

Note

- ▶ The operating program may partly or fully disable the date and time setting option.

9.5 Entering manual values into a manual sensor

Requirements

- ▶ The configuration of a channel that is to allow the entry of manual values must include the "Manual Sensor" function block (refer to online help).

How to enter manual values:

- Press jog shuttle twice. (Between the first and second presses, the LCD display shows the OTT netDL firmware version.) The OTT netDL unit activates the LCD display and shows the selection menu (if password protection for the LCD display is active → enter the four-digit password first; refer to online help).
- Press jog shuttle (**Observer**). The LCD display shows the station name, the station number, the current time and, after 2 seconds, the level of the voltage supply.
- Rotate jog shuttle to **!** and press.
- When the **Extended observer** feature is enabled in the OTT netDL configuration (the LCD display first shows a selection window): Rotate jog shuttle to **Manual Sensor** and press.
- The LCD display shows the first sensor for manual input. Rotate jog shuttle to **←**. To enter manual values of additional channels, press jog shuttle (**→**).
- To start manual input, press jog shuttle (**←**).
- The manual value is now entered by character from right to left. The character to be changed in each case is shown inverted (white on black background) and flashing.
- Rotate jog shuttle until required character appears.

- Press jog shuttle to jump to the next character position, etc.
- After entering the manual value, the time applicable to it is entered from left to right. The character to be changed in each case is shown inverted (white on black background) and flashing: The OTT netDL shows the current time as the default.
- Rotate jog shuttle until required character appears.
- Press jog shuttle to jump to the next character position, etc.
- Confirm the entry: Press jog shuttle (←). (Cancel: Rotate jog shuttle to ⏪ and press.)
- To enter manual values of additional channels, rotate jog shuttle to → and press. Then return to step 5 and repeat. After the last manual value has been entered, the LCD display shows the first channel again.
- Finish entering manual values: Rotate jog shuttle to ⏪ and press (twice); then rotate jog shuttle to the Exit position and press ("Manual sensor" present: Rotate jog shuttle to ⏪ and press; then rotate jog shuttle to the Exit position and press; then repeat complete procedure). If the jog shuttle is not used for three minutes, the LCD display shuts off automatically.

Note

- ▶ The OTT netDL unit saves a manual sensor in the same way as a normal aperiodic sensor, together with measured value, date and time.

9.6 Displaying information on Internet transmissions

A transmission is a remote data transfer that is configured in the Bedienprogramm and which the OTT netDL unit independently executes over a specified communication path. The LCD display shows information only through the "Internet" communication path!

How to display information on Internet transmissions:

- Press jog shuttle twice. (Between the first and second presses, the LCD display shows the OTT netDL firmware version.) The OTT netDL unit activates the LCD display and shows the selection menu (if password protection for the LCD display is active → enter the four-digit password first; refer to online help).
- Rotate jog shuttle to Information and press.
- Press jog shuttle (Transmissions).
 - The LCD display shows information on the first transmission:
 - Line 1: Name of the transmission;
 - Line 2: Interface and unit through which the data transmission takes place;
 - Line 3: Date and time of the last transmission through this communication path.
- Show other transmissions: Rotate jog shuttle to → and press.
- Exit display: Rotate jog shuttle to ⏪ and press; then rotate Jog shuttle twice to End and press. If the jog shuttle is not used for three minutes, the LCD display shuts off automatically.

9.7 Displaying information on connections

A connection is a communication path that is specified in the operating program and used for remote data transfer (GPRS data transfer over cellular radio modem or Ethernet or internet connection).

How to display information on connections:

- Press jog shuttle twice. (Between the first and second presses, the LCD display shows the OTT netDL firmware version.) The OTT netDL unit activates the LCD display and shows the selection menu (if password protection for the LCD display is active → enter the four-digit password first; refer to online help).
- Rotate jog shuttle to **Information** and press.
- Rotate jog shuttle to **Connections** and press.
- Optionally
 - press jog shuttle (**Modem**) or
 - rotate jog shuttle (**Network Info**) and press or
 - rotate jog shuttle (**LAN**) and press (only for OTT netDL 1000).

... for modem links (→ Modem)

- Optionally
 - Press jog shuttle (**IP connections**) or
 - Rotate jog shuttle to **Modem Status** and press.
- For IP connections: optionally
 - Press jog shuttle (**Saved status**) or
 - Rotate jog shuttle to **Current state** and press.
 - The LCD display shows information on the IP-connection:
 - Line 1: Network operator, Signal strength;
 - Line 2: IP address;
 - Line 3: Date and time of the last status logging.
- For Modem status: optionally
 - Press jog shuttle (**Modem - COM 1**) or
 - Rotate jog shuttle to **Modem - COM 2** and press (only for OTT netDL 1000) or
 - Rotate jog shuttle to **internal Modem** and press.
 - The LCD display shows information on the modem status:
 - Line 1: Name of modem (device);
 - Line 2: Network operator (optional);
 - Line: CSQ: (signal strength), GPRS: (1 = available; 0 = unavailable).
- Press jog shuttle (**End**).

... for modem links (→ Network Info)

the LCD display directly indicates the network operator, signal strength and the receivable mobile radio standard of the internal cellular modem.

- Press jog shuttle (**End**).

... for LAN connections (→ LAN)

- Optionally
 - Press jog shuttle (**Saved status**) or
 - Rotate jog shuttle to **Current state** and press (the LCD display will show the **Connection successfully established** message until the OTT netDL has determined the current status)
 - The LCD display shows information on the connection:
 - Line 1: Transmission speed of Ethernet interface
 - Line 2: IP address;
 - Line 3: Date and time of the last status logging.
- Press jog shuttle (**End**).
- Show other connections: Rotate jog shuttle to → and press.
- Exit display: Rotate jog shuttle to the **Exit** position and press multiple times. If the jog shuttle is not used for three minutes, the LCD display shuts off automatically

Note

- ▶ If the OTT netDL is unable to establish a connection, the LCD display shows " " and "-----,-----,-----,-----".

9.8 Displaying system information

Upon request, the OTT netDL shows the last 10 events recorded (event log) as well as the particular device version (Systeminfo).

How to display the event log:

- Press jog shuttle twice. (Between the first and second presses, the LCD display shows the OTT netDL firmware version.) The OTT netDL unit activates the LCD display and shows the selection menu (if password protection for the LCD display is active → enter the four-digit password first; refer to online help).
- Rotate jog shuttle to **Information** and press.
- Rotate jog shuttle to **System** and press.
- Press jog shuttle (**Event Log**).
- The LCD display shows information on the first event:
 - Line 1: Function, instance
 - Line 2: Type, code
 - Line 3: Date and time of the event
- Show information on the event in clear text → Rotate and jog shuttle to select the line 1 or 2, and press.
- Exit clear text display: Press jog shuttle (**End**).
- Display information on next event: Rotate jog shuttle to **→** and press.
- Show other events: Rotate jog shuttle to **→** and press.
- Exit display: Rotate jog shuttle to **←** and press; then rotate Jog shuttle three times to **End** and press. If the jog shuttle is not used for three minutes, the LCD display shuts off automatically.

How to display the device version:

- Press jog shuttle twice. (Between the first and second presses, the LCD display shows the OTT netDL firmware version.) The OTT netDL unit activates the LCD display and shows the selection menu (if password protection for the LCD display is active → enter the four-digit password first; refer to online help).
- Rotate jog shuttle to **Information** and press.
- Rotate jog shuttle to **System** and press.
- Rotate jog shuttle to **Systeminfo** and press.
- The LCD display shows information on the system:
 - Line 1: Type and position of the expansion card/display/mainboard/modem
 - Line 2: Hardware revision
 - Line 3: Software revision.
- Display other system information: Rotate jog shuttle to **→** and press.
- Exit display: Rotate jog shuttle to **←** and press; then rotate Jog shuttle three times to **End** and press. If the jog shuttle is not used for three minutes, the LCD display shuts off automatically.

9.9 Starting the voice announcer (on site)

When an external analog voice-enabled modem is connected to the OTT netDL unit and the voice announcer feature is enabled, measured values may be announced by voice on site.

For more information on the voice announcer functionality, please refer to Chapter 20.

How to start the voice announcer:

- Press jog shuttle twice. (Between the first and second press, the LCD display shows the OTT netDL firmware version.) The OTT netDL unit activates the LCD display and shows the selection menu (if password protection for the LCD display is enabled → enter the four-digit password first; refer to online help).
- Rotate jog shuttle to **Information** and press.
- Rotate jog shuttle to **System** and press.
- Rotate jog shuttle to **Voice announcer** and press → the OTT netDL launches the on-site voice announcer. The voice announcements may be heard through the built-in speaker of the analog modem connected.
- Finish voice announcer: Rotate jog shuttle three times to the **Exit** position and press. If the jog shuttle is not used for three minutes, the LCD display shuts off automatically.

Note

- ▶ The "Voice announcer" menu item will be available only when announcer texts are programmed in the OTT netDL unit.

9.10 Using a USB stick with the OTT netDL

The OTT netDL provides a USB host interface on the front (see Chapter 7.21). The following functions are possible with a USB stick connected to this interface:

- ▶ Read data (measured values), event log (events), device configuration and diagnosis informationen
- ▶ Update firmware and device configuration

USB stick requirements

- ▶ File system: FAT or FAT32
- ▶ Memory: 1 to 64 Gigabyte
- ▶ The following directories must exist on the stick: "[drive letter]:\OTT\config-files", "... \data-files", "... \firmware-files", "... \log-files" and "... \voice-files". The OTT netDL will create these directories automatically when the USB stick is used for the first time.



Please note:

- ▶ It is not possible to use the USB host and the USB device interface in parallel!
- ▶ Do not remove the USB stick before the LCD display is off.

How to activate the USB stick:

- Connect USB stick to the USB host interface on the front of the OTT netDL; see Fig. 31.
- Press jog shuttle twice. (Between the first and second press, the LCD display shows the OTT netDL firmware version.) The OTT netDL unit activates the LCD display and shows the selection menu (if password protection for the LCD display is enabled → enter the four-digit password first; refer to online help).

- Rotate jog shuttle to *Settings* and press.
- Press jog shuttle (*USB-A (Host)*) → the LCD display first shows various status messages and then the following options menu:
 - Data
 - System
 - Service
 - Exit

How to read out data (measured values):

- Activate USB stick (see above).
- Press jog shuttle (*Data*).
- Press jog shuttle (*Read data*) → the LCD display shows an options menu with the possible data formats:
 - OTT-ML Data
 - MIS Data
 - File Data¹⁾
 - Exit .
- Rotate jog shuttle to required data format and press.
- Set number of days required (1 to 399): rotate and press jog shuttle.
- Press jog shuttle (*Execute*) → the OTT netDL will copy the required days into the directory "... \data-files" on the USB stick (file suffixes corresponding to data format: ".OML", ".MIS", ".PWS"); the LCD display will show various status messages.
- Exit display: Rotate jog shuttle several times to *Exit* and press. If the jog shuttle is not used for three minutes, the LCD display shuts off automatically.

¹⁾ Measured values (spectre datasets) of the Present Weather Sensor OTT Parsivel² ; file suffix: ".PWS"

How to read out the event log (events):

- Activate the USB stick; see "How to activate the USB stick:".
- Press jog shuttle (*Data*).
- Rotate jog shuttle to *Read Events* and press.
- Set number of days required (1 to 399): rotate and press jog shuttle
- Press jog shuttle (*Execute*) → the OTT netDL will copy the event log of the days required into the directory "... \data-files" on the USB stick (file suffix ".OML"); the LCD display will show various status messages.
- Exit display: Rotate jog shuttle several times to *Exit* and press. If the jog shuttle is not used for three minutes, the LCD display shuts off automatically.

Notes

- ▶ The OTT netDL permanently stores all events that occurred (events) in the data memory (OTT-ML format).
- ▶ It is also possible to display the last ten events that occurred; see Chapter 9.8.

How to read out diagnosis information:

- Activate the USB stick; see "How to activate the USB stick:".
- Rotate jog shuttle to *Service* and press.

- Press jog shuttle (Read: Diagnosis) → the OTT netDL will copy several diagnosis log files into the directory "... \log-files" on the USB stick (files suffix: ".log"); the LCD display will show various status messages.
- Exit display: Rotate jog shuttle several times to End and press. If the jog shuttle is not used for three minutes, the LCD display shuts off automatically

Notes

- ▶ The OTT netDL stores diagnosis information only temporarily. After restart of the device (voltage interruption) diagnosis information will be lost!
- ▶ Diagnosis information is primarily intended for the OTT Hydroservice. In case of malfunctions it will support the cause analysis.

How to read out the configuration and to update the configuration/firmware:

- Activate USB stick; see "How to activate the USB stick:".
- Rotate jog shuttle to System and press → the LCD display shows an options menu with the available functions:
 - Update: Config
 - Read: Config
 - Update: Firmware
 - Exit

... update the configuration



Please note: the measured values stored in the OTT netDL will get irrevocably lost when the configuration is updated! If necessary, remember to read out the measured values before starting an update!

- Press jog shuttle (Update: Config).
- Rotate jog shuttle to desired configuration and press. The configuration must be in the directory "... \config-files" on the USB stick (file suffix ".bin")!
- Press jog shuttle (Continue) to confirm confirmation prompt → the OTT netDL loads the selected configuration, deletes the data memory and then restarts the OTT netDL; the LCD display shows various status messages.

... read out the configuration

- Rotate jog shuttle to Read: Config and press → the OTT netDL copies the actual configuration into the directory "... \config-files" on the USB stick (files suffix ".bin"); the LCD display shows various status messages.

... update the firmware

- Rotate jog shuttle to Update: Firmware and press.
- Rotate jog shuttle to desired firmware and press. the firmware must be in the directory "... \firmware-files" on the USB stick (file suffix ".bin")!
- Press jog shuttle (Continue) to confirm safety inquiry → the OTT netDL loads the selected firmware and then restarts the OTT netDL; the LCD display shows various status messages..

Note

- ▶ For more information regarding the firmware updates see Chapter 12.

10 LED indicators

For indicating different operating states, the OTT netDL unit front panel has two multi-color LEDs:

- ▶ "Logger" LED
 - Flashes green; frequency: once every 2 seconds (0.5 Hz)
 - datalogger active
 - Flashes green; frequency: once per second (1 Hz)
 - IP data communication active
 - Flashes red; frequency: once per second (1 Hz)
 - IP data communication failed
 - Off
 - datalogger in sleep mode
- ▶ "Modem" LED
 - Continuously illuminates green
 - internal modem is powered
 - Flashes orange; frequency: once per second (1 Hz)
 - internal modem tries to login into cellular network
 - Flashes orange; frequency: once every 2 seconds (0.5 Hz)
 - internal modem logged in into cellular network
 - Off
 - internal modem in sleep mode

On the OTT netDL 1000 unit, the RJ-45 socket is provided with two additional LEDs for checking the Ethernet interface (refer to Figure 28):

- ▶ LED A (Link Status) - Continuously illuminated
 - Link to an Ethernet LAN or DSL router is established
- ▶ LED B (Traffic) - Flashing
 - Transmitting and receiving activities over the Ethernet interface are taking place.

When both LEDs are permanently off, the Ethernet interface may be in sleep mode. Using the *Information | Connections | LAN | Current state* feature (operate/set the OTT netDL on site), you may temporarily enable the Ethernet interface (refer to Chapter 9.7).

11 Reading out measured data on site

To retrieve measured data from an OTT netDL unit, a PC with the "Hydras 3 Application Software (Basic)" is required.

How to retrieve measured data on site:

- Connect the RS-232 interface port of the OTT netDL unit (if it is used: disconnect the connection cable to the external communication device. When the COM 1 interface is configured for voice announcer, data can no longer be read through this interface) to the PC serial interface using the RS-232 data transfer cable, **or** connect the USB interface port (device) of the OTT netDL to the USB interface of the PC (host) using a USB cable.
- Start Hydras 3.
- In the tree view of OTT Hydras 3, select the respective station, and in the "Communication" menu, select the "Read/Operate" option.
- In the "Hydras 3 – Communication" window, "OTT netDL" type, "Read: Standard (selective)", select the "RS232C/V.24, COM1 (or COM2), 115200Bd, 8N1" **or** "USB" communication path.
The protocol type is preset to "OTT Protocol (Hydrosens, ...)".
- Select the required sensors or "All sensors".
- Select the required read period or "All".
- Select the "Start" button → OTT Hydras 3 copies the measurement data from the OTT netDL to the PC. The data is then available for further use in the raw data pool.
- Disconnect the RS-232 data transfer cable and – as applicable – reconnect the connection cable to the external communication device **or** remove the USB cable.

Note

- ▶ For reading measurement data through the USB interface of the OTT netDL, OTT Hydras 3 release 2.90.0 (or higher) is required!

Fig. 36: Reading out measured data on site.

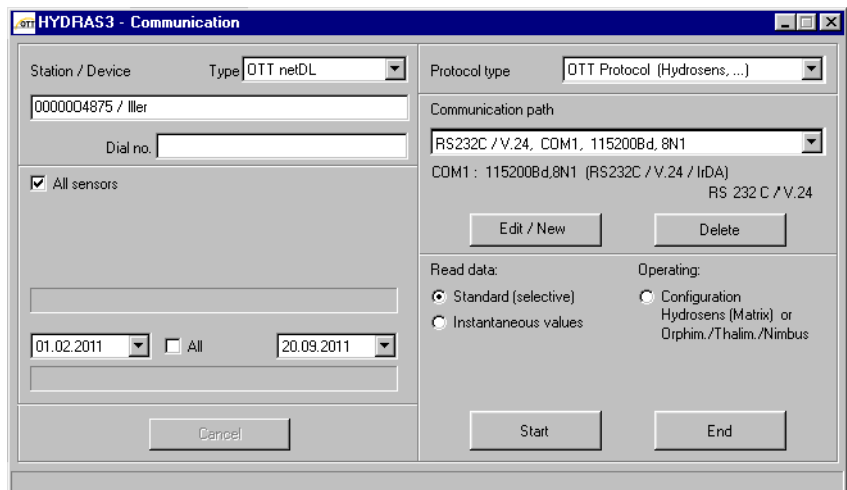

Moreover, you may retrieve the measured data through remote data transfer using a modem. For detailed information, refer to the online help of the operating program.

Alternatively you may read out the measured data to a USB stick which is connected to the OTT netDL; see Chapter 9.10

12 Updating the OTT netDL firmware

The operating program provides the option of updating the OTT netDL firmware (operating system). By continuously developing the operating system, you will thus be provided with the extended functionality for the OTT netDL, even with the same hardware.

By accessing the OTT website (www.ott.com; "myOTT" section) from time to time, stay informed on the current version of the OTT netDL firmware.

How to update the firmware:

- Download the new version of the firmware (file: e.g. "5555230293_03020_netDL.bin") from the website.
- Move the "5555230293_XXXXX_netDL.bin" file into the installation directory of the operating program.
- Establish the PC/OTT netDL communication link (refer to Chapter 8.2).
- In the "OTT netDL ..." menu, select the "New program code" option.
- Select the current update file and then click on the "Open" button. (The operating program automatically changes to its installation directory.)
- Acknowledge the confirmation by selecting "Yes" → The operating program copies the new firmware to the OTT netDL unit (LCD display: "Update in progress"). Then the OTT netDL will restart and automatically resume processing its measuring and communicating jobs.



Please note: During update, make sure that the communication link is not aborted (e.g. by accidentally answering calls on the data transfer cable). If the communication link is aborted, the firmware will no longer be executable! In the same way, no other programs should be started or files opened during the copying process!

Notes

- ▶ The measured values saved in the OTT netDL are not lost after an update.
- ▶ Alternatively you may update the firmware also via a USB stick which is connected to the OTT netDL; see Chapter 9.10

13 Overview: Alarm and action management

The OTT netDL is capable of automatically generating an alarm or performing an action, if certain events occur. These alarms or actions may be triggered by different conditions:

- ▶ Threshold of a limit: A predefined value is underrun or exceeded.
- ▶ Gradient limit: Fast rise or drop of a defined value within a certain period of time.
- ▶ Change in status: The input signal at a status input has changed.

The following actions and alarm messages are available:

- ▶ Control external devices through the power supply switching contact (switched U_{bat}).
- ▶ Send an SMS message containing an alarm message. If the cellular radio network operators provide respective services, the SMS messages may be sent as an e-mail or telefax as well.
- ▶ Send an alarm message via OTT protocol to the OTT Hydras 3 application software.
- ▶ Send an alarm message to an HTTP/HTTPS/FTP/SMTP server.
- ▶ Temporarily change the transmitting interval of a configured data transfer. For this, there are five additional time intervals available that are controlled by limits.
- ▶ (Temporarily) change the sampling and storage interval of a channel.
- ▶ Establish the dial-up connection and start the voice announcer (alarm message).

If required, individual actions may be grouped. Thus, an event may trigger several actions/alarms.

For detailed information on the alarm and action management, refer to the online help of the operating program.

14 Protecting the OTT netDL unit using a password

To protect an OTT netDL against unauthorized configuration or entry of operating parameters, you may lock the OTT netDL unit using a password. This only applies to the interaction with the operating program.

How to protect the OTT netDL against unauthorized operation:

- Establish the PC/OTT netDL communication link (refer to Chapter 8.2).
- Read the current OTT netDL configuration into the operating program: In the "netDL 500/1000" menu, select the "Read" option or click on the "Read" button.
- In the tree view, select "netDL 500/1000".
- Enter an eight-digit (max.) password into the "Password" input box.
Allowable characters: 0-9, A-Z.
- Click on the "Program" button.
- Acknowledge the message "Warning: Reset the netDL and delete data memory additionally?" by selecting "No" → The OTT netDL unit is now protected against unauthorized operation.

Please note: Keep the password in a safe place. If the password is lost, you can no longer configure or parametrize the OTT netDL unit. In such a case, please contact OTT HydroService.

How to unlock the OTT netDL for operating:

- In the "netDL 500/1000" menu, select the "Enter password" option.
- Enter password.
- Click on the "OK" button.
- Acknowledge the " Password accepted! OTT netDL unlocked" message by selecting "OK".
- Click the "Read" button → The operating program reads the current OTT netDL configuration.

15 Setting date and time

The internal clock of the OTT netDL is a highly accurate realtime clock. If the supply voltage is interrupted, the installed lithium battery provides the voltage supply for the realtime clock. Date and time are set using the operating program (or through the LCD display and jog shuttle, refer to Chapter 9 "Operating/configuring the OTT netDL unit on site").

How to set the date and time

- Establish the PC/OTT netDL communication link (refer to Chapter 8.2).
- In the "netDL 500/1000" menu, select the "Date/time" option → The operating program opens the "netDL 500/1000 – date/time" window and retrieves both date and time of the OTT netDL unit.
- Click the "Set date/time" button → The operating program sets the OTT netDL date and/or the OTT netDL time according to the PC time/the PC date and/or according to the date/time set in the selection box.
- If necessary: Click the "Refresh" button → The operating program retrieves the OTT netDL date and time again.
- Click the "Exit" button.



Please note: If the PC is in Daylight Saving Time mode (identified by "DST" on the PC), the operating program will automatically use the standard time without taking into account the daylight saving time (standard time). To obtain continuous time series, it is reasonable not to use the daylight saving time on the OTT netDL unit. (The OTT netDL does not have an automatic daylight saving time feature.)

16 Deleting the data memory



Please note: The measured values stored in the OTT netDL are permanently lost when deleting the data memory! Where necessary, retrieve the measured values before deleting (refer to Chapter 11).

How to delete the data memory

- Establish the PC/OTT netDL communication link (refer to Chapter 8.2).
- In the "netDL 500/1000" menu, select the "Delete data memory" option.
- Acknowledge the message "Warning: Are you sure you want to delete data memory?" by selecting "Yes" → The operating program deletes the entire data memory of the OTT netDL (all measured value channels including the info channel). Deleting the data memory takes about 30 seconds.

Then the OTT netDL unit resumes determining and storing the measured values of all channels available, using the individually set sample interval.













17 Creating and printing the terminal connection diagram

For documentation purposes, the operating program provides the option of printing a terminal connection diagram. This terminal connection diagram is based on the configuration that is saved in the tree view of the OTT netDL. Additionally, the connection diagram includes images of the front panel and rear side of the OTT netDL model that is required for this configuration.

How to create and print a terminal connection diagram:

- Establish the PC/OTT netDL communication link (refer to Chapter 8.2).
- Read the current OTT netDL configuration into the operating program: In the "netDL 500/1000" menu, select the "Read" option or click on the "Read" button. (Alternatively: create a new configuration in the operating program. Step 1 can be omitted in this case.)
- In the "File" menu, select the "Print Connection diagram" option → The print preview window opens and shows the connection diagram.
- Click the printer icon  → The operating program prints the terminal connection diagram.

Buttons in the print preview window:

-  Optimum size; show whole page of connection diagram
 -  Show connection diagram at 100% scale
 -  Scale connection diagram to screen width
 -  Go to first page of the connection diagram
 -  Go to previous page of the connection diagram
 -  Go to next page of the connection diagram
 -  Go to last page of the connection diagram
 -  Printer setup (standard Windows dialog)
 -  Print the connection diagram
 -  Save connection diagram as "QuickReport" file (*.QRP)
 -  Open saved connection diagram ("QuickReport" file)
-  Schließen Close print preview window

18 Creating and printing a device view

Using the "Device view" feature of the operating program, you may determine, view, and print the present model of the OTT netDL unit (front and a rear side).

How to create and print a device view:

- Establish the PC/OTT netDL communication link (refer to Chapter 8.2).
- Select „netDL 500/1000“, "Device view" feature → the print preview window opens and shows the front and rear views of the OTT netDL.
- Select the printer icon  → the operating program prints the device view. For an explanation of the buttons in the print view window, please refer to Chapter 17.

19 OTT-SDI Transparent mode

For maintenance or calibration operations on a sensor with SDI-12 interface, the OTT netDL unit has a so-called "Transparent mode". Using a mode in the operating program that is similar to terminal emulation, it is possible to directly communicate with the sensor via the OTT netDL. For this purpose, various SDI-12 commands are available. In this case, the OTT netDL transfers the commands to the sensor, activates it, and returns the responses of the sensor to the terminal window.

Further information on the available commands of an SDI-12 sensor can be found in the operating instructions of the sensor.

Alternatively, the "OTT SDI-12 Interface" software is available. Using this software, you may send SDI-12 commands to a sensor fitted with an SDI-12 interface in a very convenient manner. The software clearly displays the response in plain text the sensor sends upon receiving an SDI-12 command.

How to use the OTT-SDI Transparent mode:

- Establish the PC/OTT netDL communication link (refer to Chapter 8.2)
- Start the terminal emulation: In the "netDL 500/1000" menu, select the "Terminal mode" option.
- Wake the OTT netDL unit up: **A**<Enter key> (several times, if required). Return value: **?08**
- Start the OTT-SDI Transparent Mode: **CL/SDI/TRANSP**<Enter> (sensor is connected to screw terminal strip C, terminals 3/4) or **CL/OTTS-DI/TRANSP**<Enter> (sensor is connected to screw terminal strip C, terminal 1/2) → command prompt for SDI-12 commands appears: SDI-12>
- Gewünschtes SDI-12-Kommando eingeben (omit the ! Character at the end of an SDI-12 command, it will be automatically added by the operating program). The sensor will return an appropriate response.
- OTT-SDI Transparent mode : **quit**<Enter>.
- Exit terminal mode: Press ESC key.

Fig. 37: Terminal emulation (terminal mode) in the operating program with two exemplary commands used in OTT-SDI Transparent mode.

```
netDL 500 - Terminal mode (USB)
A
A
?08
CL/OTTS-DI/TRANSP

OTT-SDI Transparent Mode Start!
(Leave this mode with the command 'quit<cr>')
Do not enter ! at SDI command end
OTT-SDI>OM0
00022<cr><lf>
OTT-SDI>
0<cr><lf>
OTT-SDI>0D0
0+0.060+22.8<cr><lf>
OTT-SDI>quit

OTT-SDI Transparent Mode End!

DONE

CL/DEVICE
ESC to exit
```

Please note:

- ▶ Note case sensitivity.
- ▶ Upon incorrect entries, the sensor returns an **< Error >**.
- ▶ If communication is faulty, end terminal mode (ESC button), wait 5 seconds, then restart terminal mode.
- ▶ If the OTT netDL is in measuring mode (e.g. the sample interval of a sensor is active), the response from the sensor is delayed.

How to launch the "OTT SDI-12 Interface" software:

- Establish the PC/OTT netDL communication link (refer to Chapter 8.2).
- In the "Tools" menu, select the "SDI Interface" feature → the operating program starts the separate "OTT SDI-12 Interface" software. Through the OTT netDL unit, the software establishes a communication link to the SDI-12 sensor. Then the software provides a selection of SDI-12 commands that match the sensor type connected.
- Select the required SDI-12 command.

For more information on the "OTT SDI-12 Interface", please refer to the separate online help.

20 Voice announcer functionality overview

The voice announcer for measured values and alarm messages through a dial-up connection can be used in three different ways:

- ▶ Through a voice-enabled analog modem (recommended model: devolo MicroLink™ 56k i); connected to the COM 1 serial interface port or
- ▶ Through a voice-enabled ISDN terminal adapter (recommended model: Stollmann TA+ODD); connected to the COM 1 serial interface port or
- ▶ Through the OTT netDL internal cellular modem (version code "C...").

The recommended external communication devices (modem/terminal adapter) are available from OTT as accessories. They meet all necessary requirements and have been thoroughly tested in conjunction with the OTT netDL unit.

Furthermore, the OTT netDL must be enabled for using the voice announcer feature in factory. For this, two options are available:

- ▶ OTT provides an OTT netDL unit that is configured for the voice announcer. In such a case, you will get a questionnaire after placing the order which is used to gather all relevant announcer texts. Then these announcer texts are generated in factory and programmed into the OTT netDL unit. No further adjustments are required to be made in this case. The voice announcer feature will be available immediately after applying the supply voltage.
- ▶ OTT provides standard voice modules for individually compiling announcer texts in the operating program. Then you must program these texts into the OTT netDL unit.

When an external analog modem is used, measured values may also be announced on site.

For detailed information on the voice announcer feature, please refer to online help in the operating program.

Note

- ▶ Technical prerequisite for acknowledging a successfully transferred alarm message: The alarm message must have been sent through an analog modem or ISDN terminal adapter. (For acknowledging, you must press 1 to 3 specified keys on the called telephone.)

21 Error messages

21.1 Internal error messages

Display: **Lxx**

Internal errors arise when recording and processing measured values in the entire measurement route from the sensor to storing in memory or on the display.

- 00 – Measured value is ok
- 01 – AD conversion faulty
- 02 – Communication error
- 03 – Over/underflow
- 05 – Wire break
- 06 – Sensor type dependent
- 07 – IP communication error (IP coupling): measured value (or picture) is missing
- 08 – IP communication error (IP coupling): measured value is no longer valid
- 10 – Measured value not (yet) logged;
"ERR10" indicates missing measured values in the data memory which
 - are not yet logged temporally, or
 - could not be recorded due to a short and temporary disturbance (single measured values). As they cannot be avoided in all cases, due to technical reasons, they occur occasionally even during normal operation.

21.2 External error messages

Display: **Sxx**

External errors occur in "intelligent sensors" and are sent to the OTT netDL.

21.3 Sensor error messages

Analog input

- Internal errors:
- 01 Analog-digital conversion faulty
 - 03 over-/underflow
 - 0-1,25 V: $U_{in} < -0,1 \text{ V}$ or $U_{in} > 1,375 \text{ V}$
 - 0-10 V: $U_{in} < -0,5 \text{ V}$ or $U_{in} > 11,0 \text{ V}$
 - 0-5 V: $U_{in} < -0,5 \text{ V}$ or $U_{in} > 5,5 \text{ V}$
 - 0-50 mV: $U_{in} < -5 \text{ mV}$ or $U_{in} > 55 \text{ mV}$
 - 0-20 mA: $I_{in} < -2 \text{ mA}$ or $I_{in} > 22 \text{ mA}$
 - 4-20 mA: $I_{in} < +2 \text{ mA}$ or $I_{in} > 22 \text{ mA}$
 - Pt 100: $t < -100 \text{ °C}$ or $t > 140 \text{ °C}$
 - Potentiometer: $R < -10 \%$ or $R > 130 \%$
 - 04 Timeout during measurement
 - 05 Wire break
- External errors: None

Pulse input

- Internal errors: None
- External errors: None

Kalesto

- Internal errors:
- 01 Set minimum signal level underrun
 - 02 Communication error
 - 05 Wire break
- External errors:
- 01 Reflexion level too low
 - 02 Multiple-target situation. No measured value can be determined
 - 04 Measurement range exceeded, measured value $< 1.50 \text{ m}$ or $> 30.00 \text{ m}$
 - 08 A constant measured value cannot be determined

Sonicflow

Internal errors: 01 over-/underflow
02 Communication error
04 Wire break
05 Missing water level
External errors: 01 Signal level underrun

Parsivel

Internal errors: 02 Communication error
05 Wire break
External errors: None

SDI sensor and SDI sensor via RS-485

Internal errors: 02 Communication error
05 Wire break: Sensor not responding
External errors: 01 Communication error: Sensor sending fewer (or no)
measured values than indicated
02 Communication error: Sensor sending more
measured values than indicated
03 Over-/underflow: SDI sensor sending "99999"
04 Incorrect SDI-12 address

RS-232-Eingang

Internal errors: 02 Communication error
03 over-/underflow
04 Timeout during measurement
05 Wire break
06 A forwarded error message of the connected
"intelligent" sensor is present
External errors: None

21.4 Error messages of the processing modules

Linearization table

Internal errors: 03 Table limits exceeded/underrun
("☑ No extrapolation" feature enabled)
External errors: None

Q calculation

Internal errors: 03 Table limits exceeded/underrun
("☑ No extrapolation" feature enabled)
External errors: None

22 Maintenance

The OTT netDL has a battery-backed realtime clock. Thus the clock continues to run with high accuracy, even if power supply fails. The backup battery has a service life of approximately 10 years. To some extent, its service life depends on the time of storage without power supply connected as well as on the existing ambient temperatures.

To ensure correct time under all conditions, we suggest having the backup battery replaced in factory every 5 years.

For battery replacement, please contact the OTT repair center, refer to Chapter 23.

The OTT netDL unit does not require any other maintenance.



Never open the housing of the OTT netDL! There are no adjustment or control elements inside the housing!

23 Repair

■ In case of device failure, please contact the repair center of OTT:

OTT Hydromet GmbH
Repaircenter
Ludwigstrasse 16
87437 Kempten · Germany
Phone +49 831 5617-433
Fax +49 831 5617-439
repair@ott.com

Please note: Have a faulty OTT netDL unit checked and/or repaired only by the OTT repair center. Never attempt to repair the unit yourself! Any repairs or attempted repairs carried out by the customer will void any warranty.

24 Notes about the disposal of used units



Within the member countries of the European Union

In accordance with the European Union guideline 2002/96/EC, OTT takes back old devices within the member countries of the European Union and disposes of them in an appropriate way. The devices concerned by this are marked with the symbol shown aside.

- For further information on the return procedure, please contact your local sales contact. You will find the addresses of all sales partners in the internet on "www.ott.com". Please take into consideration also the national implementation of the EU guideline 2002/96/EC of your country.

For all other countries

- Dispose of the OTT netDL properly after taking out of service.
- Observe the regulations applicable in your country for the disposal of electronic devices.
- Never put the OTT netDL into the normal household waste.

Materials used

Refer to Chapter 25 "Technical data".

25 Technical data

Supply voltage	+9 to +28 V _{DC} ; typ. +12 V _{DC}
Power consumption (at 12 V _{DC})	
active	approx. 25 mA to 400 mA (depending on configuration) Examples: – Modem inactive, measuring mode: < 30 mA (OTT netDL 500, Pt100) – Modem active, measuring mode: < 60 mA (OTT netDL 500, Pt100: maintenance window active) – Modem + LAN active, measuring mode: < 400 mA (OTT netDL 1000; 2 x 4-20 mA internal supply, galvanically isolated; 2 x Pt100; output card; maintenance window active) < 10 mA
Sleep mode, pulse active	< 250 µA
Sleep mode	36 V ¹⁾
Input protection levels	
Display	Graphic DOT matrix, 122 x 32 pixels, monochrome, background lighting, operating temperature: -20 °C - +70 °C
Clock	
Type	Battery-backed realtime clock
Accuracy	±8 seconds/month (at +25 °C)
Backup battery type	CR 2032; 3 V
Life of backup battery	10 years (replacement after 5 years recommended)
Communication interfaces	– 1 x RS-232-C; OTT netDL 1000: 2 x – USB host + USB device – OTT netDL 1000: Ethernet 10 Mbit (RJ-45)
IP communication	– Internal TCP/IP stack (HTTP, FTP, SMTP, SNMP, ...) – Internal web server – TCP/IP communication over GPRS, Ether- net/DSL and PPP over PSTN – Encrypted data transfer via SSL 3.0 / TLS 1.0, 1.1, 1.2 (HTTPS; key lengths 512 to 2048 Bit; ECDH/DH algorithms are not supported)
Internal cellular modem	
Device versions "B..." / "C..."	GSM/GPRS 900/1800, 850/1900 MHz;
Device version "D..."	GSM/GPRS; UMTS/HSPA+ 900/1800, 850/1900 MHz; 800/850, 900, AWS 1700, 1900, 2100 MHz
Antenna	External, with SMA connector, allowable antenna gain (including cable): 3.71 dBi max.; minimum clearance between antenna and persons and unit > 20 cm!

Length of connection cables

USB host + USB device interface	max. 3 m
RS-232-C interface	max. 3 m
Radio antenna	max. 3 m

¹⁾ Protection against externally applied voltage (static) on the inputs

Inputs (depending on configuration)

Pulse input	
Frequency	0-50 Hz
Debouncing	8-100 ms (adjustable)
Min. pulse duration	> 8 ms
Max. contact resistance	10 kOhms
Voltage	5-28 V
Max. contact load	< 500 μ A (per contact)
Status input	
Frequency	0-50 Hz
Max. contact resistance	10 kOhms
Voltage	5-28 V
Max. contact load	< 500 μ A (per contact)
Analog input	
A/D converter resolution	24 bits
Input ranges "Voltage"	0-50 mV; 0-1.25 / 5 / 10 V
R_i with reference to ground	4 MOhms typ. / 100 kOhms typ.
R_i with floating voltages	> 100 MOhms
Accuracy	0.1 % of full scale
Resolution	0-50 mV: 50 μ V; rest: 1 mV
Measuring time	< 350 msec
Galvanic isolation (optional)	500 V
Input ranges "Current"	0-20 mA; 4-20 mA
R_i	50 Ohms typ. / 400 Ohms max.
Accuracy	0.1 % typ. / max. 0.3 % of full scale
Resolution	1 μ A
Measuring time	< 350 msec
Supply voltage for external sensors	typ. 24 V; max. 28 V at supply voltage > 24 V
Max. output current	25 mA
Galvanic isolation (optional)	500 V
"Potentiometer" input range	0-5.5 kOhms
Accuracy	1000 ppm of full scale
Resolution	100 ppm
Measured value output	0 to 120 % (of nominal value of potentiometer)
Measuring time	1000 msec
Wire break detection at	typ. >13 kOhms
"Pt 100" input range	-40 - +85 $^{\circ}$ C
Accuracy	\pm 0.1 K (-40 - +70 $^{\circ}$ C; w/o cable)
Resolution	0.01 K
Measuring time	850 msec
Galvanic isolation (optional)	500 V

Input RS-232 interface	OTT protocol (instantaneous value, last saved value, time synchronization; pins 2, 3 + 5)																																								
Protocol																																									
Pin assignments	<table> <thead> <tr> <th>Pin</th> <th>Signal</th> <th></th> <th>Direction</th> </tr> </thead> <tbody> <tr> <td>1</td> <td>Carrier Detect</td> <td>DCD</td> <td>In</td> </tr> <tr> <td>2</td> <td>Receive Data</td> <td>RxD</td> <td>In</td> </tr> <tr> <td>3</td> <td>Sent Data</td> <td>TxD</td> <td>Out</td> </tr> <tr> <td>4</td> <td>Data Terminal Ready</td> <td>DTR</td> <td>Out</td> </tr> <tr> <td>5</td> <td>Ground</td> <td>GND</td> <td>GND</td> </tr> <tr> <td>6</td> <td>Data Set Ready</td> <td>DSR</td> <td>In</td> </tr> <tr> <td>7</td> <td>Request To Send</td> <td>RTS</td> <td>Out</td> </tr> <tr> <td>8</td> <td>Clear To Send</td> <td>CTS</td> <td>In</td> </tr> <tr> <td>9</td> <td>Ring Indicate</td> <td>RI</td> <td>In</td> </tr> </tbody> </table>	Pin	Signal		Direction	1	Carrier Detect	DCD	In	2	Receive Data	RxD	In	3	Sent Data	TxD	Out	4	Data Terminal Ready	DTR	Out	5	Ground	GND	GND	6	Data Set Ready	DSR	In	7	Request To Send	RTS	Out	8	Clear To Send	CTS	In	9	Ring Indicate	RI	In
Pin	Signal		Direction																																						
1	Carrier Detect	DCD	In																																						
2	Receive Data	RxD	In																																						
3	Sent Data	TxD	Out																																						
4	Data Terminal Ready	DTR	Out																																						
5	Ground	GND	GND																																						
6	Data Set Ready	DSR	In																																						
7	Request To Send	RTS	Out																																						
8	Clear To Send	CTS	In																																						
9	Ring Indicate	RI	In																																						
Worst case timeout per measured value	55 sec																																								

Input RS-485 interface	OTT protocol; SDI-12 via RS-485; Modbus
Protocol	
Interface layout	2-wire, half-duplex
Transfer speed	1 200 to 57 600 bps
Line termination	Yes, 120 ohm

Input SDI-12 interface	SDI-12 specifications, V 1.3
Protocol	
Interface layout	SDI-12 specifications, V 1.3

Outputs (depending on configuration)

Switching output	
Voltage	max. 16 V _{DC}
Leakage current	< 1 μA / 28 V _{DC}
Current capacity	max. 5 A (no fuse provided, external fuse required)
Status output:	
Voltage	max. 28 V _{DC}
Leakage current	< 1 μA / 28 V _{DC}
Current capacity	max. 100 mA
Load disconnect (short-circuit disconnect)	at 200 mA
4-20 mA output (galvanically isolated)	
External supply	9-28 V _{DC}
Accuracy	< ±0.1 % of full-scale at 25 °C +10 ppm/K
Resolution	16 bit
Burden	<350 Ohms (referenced to 9 V _{DC} supply)
Ripple (20 mA)	<100 μA RMS
Burden dependency	< 1 ‰
Potential	Floating (galvanically isolated)
Isolation	500 V
Loop monitoring	Configurable

Data memory

Storage capacity available for measured values	30.8 MB
Number of measured values that can be stored	approx. 1,100 000
Data storage type	Ring buffer (FIFO)
Number of logical channels	
Standard	40
with software expansion "120 Channels"	120
Operating system	RTOS, modified for minimum current consumption

Mechanical limits

Overall dimensions (L x W x H)	
OTT netDL 500	148 mm x 124 mm x 68 mm
OTT netDL 1000	232 mm x 124 mm x 68 mm
Weight	
OTT netDL 500	Approx. 0.400 kg (depending on configuration)
OTT netDL 1000	Approx. 0.650 kg (depending on configuration)
Housing material	ABS
Protection class	IP 41
Temperature range	
Operating temperature	-40 °C to +70 °C (internal modem: -30 °C to +70 °C)
Storage temperature	-50 °C to +85 °C
Relative humidity	5 % - 95 % (non-condensing)
FCC ID	
Device versions "B..." / "C..."	RI7GE910
Device version "D..."	RI7HE910

Appendix A – OTT netDL 500 / OTT netDL 1000 Declaration of Conformity

If required, you can download the current version of the declaration of conformity for the OTT netDL 500 / OTT netDL 1000 from our website as a PDF file: "www.ott.com/resources".



Appendix B – Special application: connecting four sensors with voltage-/power output to an analog input card

The hardware expansions "Analog input card" and "Analog input card, galvanically isolated" both have **two** separate inputs for analog input signals (one input per screw terminal; see Chapter 7.7 to 7.10).

If more than 4 (OTT netDL 500) or 6 (OTT netDL 1000) analog inputs are required, it is also possible to connect two sensors with voltage-/power output to one screw terminal. The precondition is an additional input wiring with external resistors (indirect current measurement over shunt resistor or voltage measurement over voltage divider; not for input combination "B.1").

For this action, **four** inputs per analog input card are available (→ max. number of analog inputs: OTT netDL 500: 8; OTT netDL 1000: 12).

The following input combinations are possible:

- ▶ "0 / 4-20 mA, internal supply" + "0-5 / 10 V" (B.1)
- ▶ "0 / 4-20 mA, external supply" + "0-5 / 10 V" (B.2)
- ▶ "0 / 4-20 mA, external supply" + "0-50 mV / 1,25 V" (B.3)
- ▶ 2 x "0-5 / 10 V" (B.4)
- ▶ 2 x "0 / 4-20 mA, external supply" (B.5)

With temperature sensors (Pt 100) and sensors with potentiometer, the connection of two sensors to one screw terminal is not possible. These sensors require all four connections of the screw terminal.

Please note:

- ▶ Always set the same screw terminal for channel 1 and 2 in the OTT netDL configuration (operating program) (e.g.: "G")!
- ▶ Use only precision resistors with $\pm 0,1$ % tolerance (see accessories) for the external wiring.
- ▶ If the "analog input card, galvanically separated" is used: there is no galvanic separation between the two inputs (exception: input combination "B.1")! The galvanic separation between the inputs and the OTT netDL and also between the two screw terminals is always safe.

B.1 Input combination "0/4-20 mA, internal supply"+ "0-5/10 V"

Settings in the OTT netDL configuration (operating program):

- Channel 1** Measuring mode: "I 0-20mA int." or "I 4-20mA int."
Scaling: not required
- Channel 2** Measuring mode: "U 0-5V" or "U 0-10V"
Scaling: not required

Fig. B1: One sensor with voltage- and one with power output (internal supply) connected parallel to a screw terminal of the OTT netDL (analog input card).

The connection to the other screw terminal of the analog input card is done in the same way.

Please note: do **not** connect additional external supply to the sensor!

If the voltage supply of the OTT netDL is higher than 24 V (max. 28 V): the connected sensor must be suitable for voltages higher than 24 V!

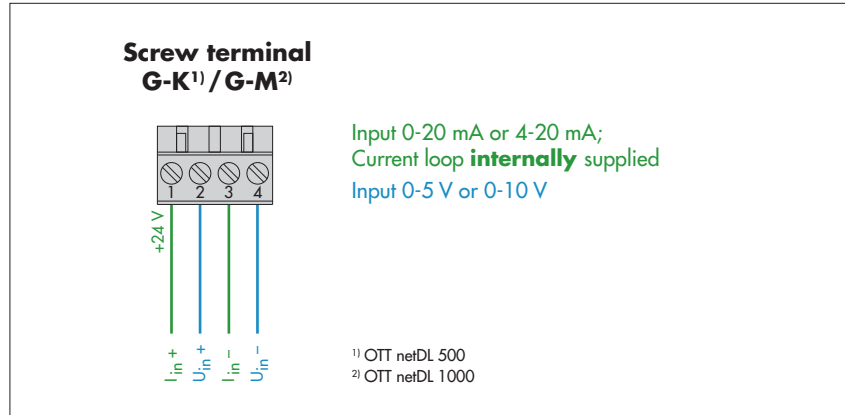

B.2 Input combination "0/4-20 mA, external supply"+ "0-5/10 V"

Settings in the OTT netDL configuration (operating program):

- Channel 1** Measuring mode: "U 0-1.25V" (→ indirect power measurement)
Scaling: "y = ax + b" with a = 20 and b = 0
- Channel 2** Measuring mode: "U 0-5V" or "U 0-10V"
Scaling: not required

Fig. B2: One sensor with voltage- and one with power output (external supply) connected parallel to a screw terminal of the OTT netDL (analog input card).

The connection to the other screw terminal of the analog input card is done in the same way.

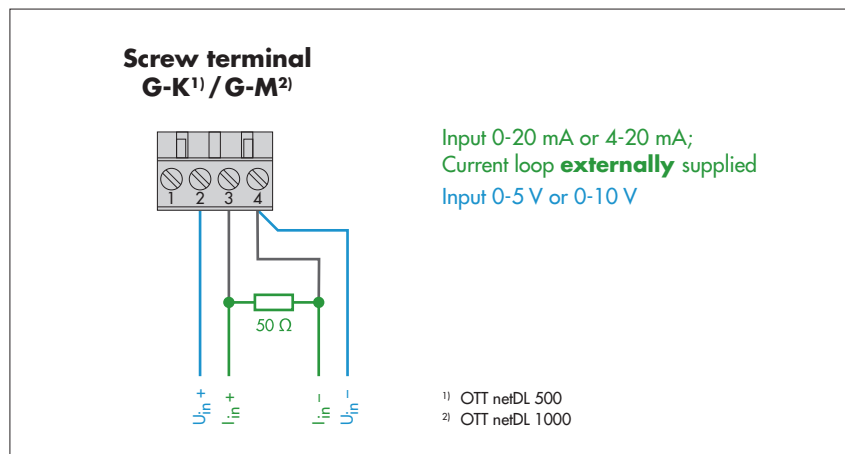

B.3 Input combination "0/4-20 mA, external supply" + "0-50 mV/1.25 V"

Settings in the OTT netDL configuration (operating program):

- Channel 1** Measuring mode: "U 0-50mV" or "U 0-1.25V"
Scaling: not required
- Channel 2** Measuring mode: „U 0-5V“ (→ indirect power measurement)
Scaling: "y = ax + b" with a = 20 and b = 0

Fig. B3: One sensor with voltage- and one with power output (external supply) connected parallel to a screw terminal of the OTT netDL (analog input card)

The connection to the other screw terminal of the analog input card is done in the same way.

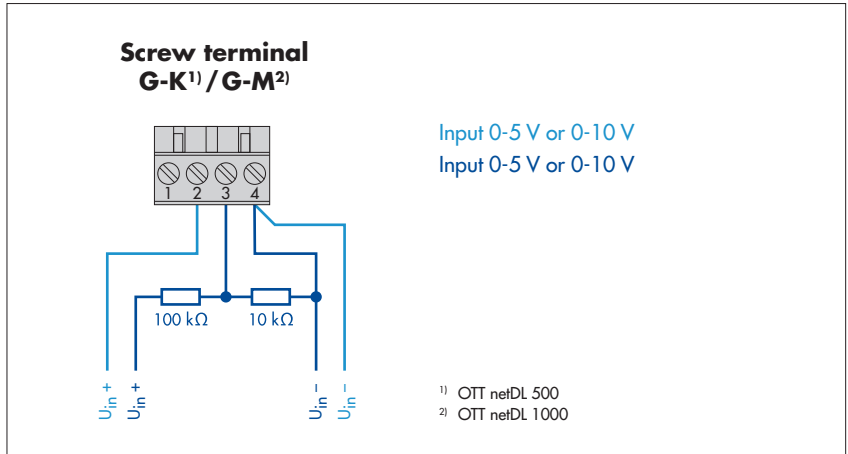

B.4 Input combination 2 x "0-5/0 V"

Settings in the OTT netDL configuration (operating program):

- Channel 1** Measuring mode: "U 0-5V" or "U 0-10V"
Scaling: not required
- Channel 2** Measuring mode: "U 0-1.25V" (→ measurement via voltage divider)
Scaling: "y = ax + b" with a = 11 and b = 0

Fig. B4: two sensors with voltage output connected parallel to a screw terminal of OTT netDL (analog input card).

The connection to the other screw terminal of the analog input card is done in the same way.

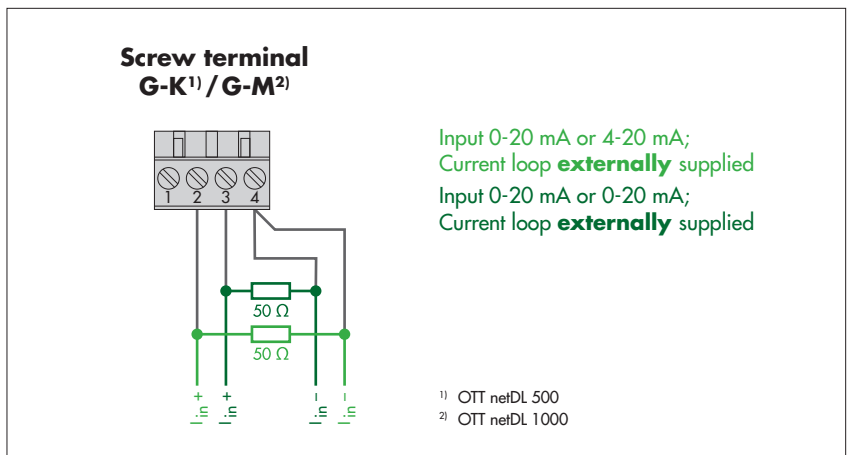

B.5 Input combination 2 x "0/4-20 mA, external supply"

Settings in the OTT netDL configuration (operating program):

- Channel 1** Messmode: "U 0-1.25V" (→ indirect current measurement)
Scaling: "y = ax + b" with a = 20 and b = 0
- Channel 2** Measuring mode: "U 0-5V" (→ indirect current measurement)
Scaling: "y = ax + b" with a = 20 and b = 0

Fig. B5: two sensors with power output (external supply) connected parallel to a screw terminal of the OTT netDL (analog input card).

The connection to the other screw terminal of the analog input card is done in the same way.

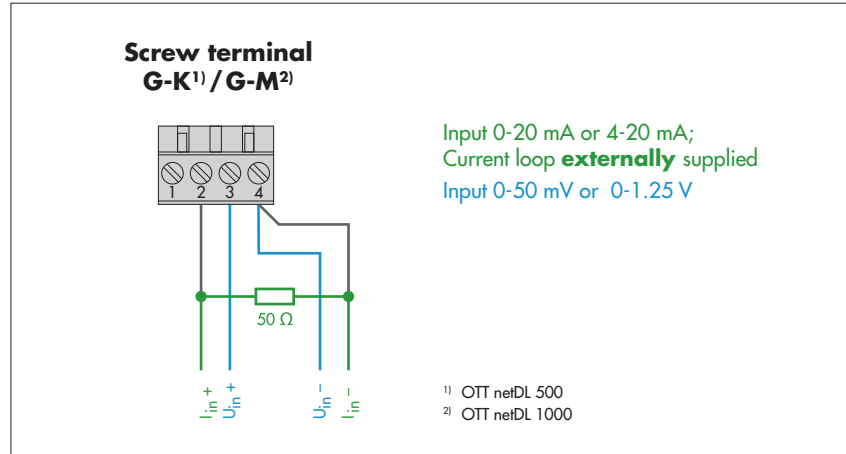

Document number
55.552.001.B.E 04-0917



OTT Hydromet GmbH

Ludwigstrasse 16
87437 Kempten · Germany
Phone +49 831 5617-0
Fax +49 831 5617-209

info@ott.com · www.ott.com