

Accubar® Constant Flow Bubble Gauge/Recorder 56-0133 and Dual Orifice Bubble Gauge/Recorder 56-0134

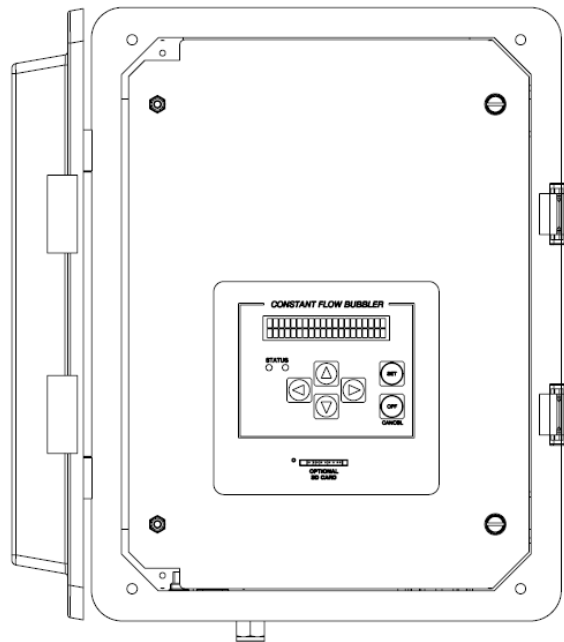

OPERATIONS & MAINTENANCE MANUAL

Part No. 8800-1167
Revision – 1.83.1
May 9th, 2023

Table of Contents

INTRODUCTION	6
FEATURES	6
DUAL ORIFICE BUBBLER.....	7
DUAL ORIFICE BUBBLER ADDITIONAL FEATURES	7
UNPACKING.....	8
PNEUMATIC FEATURES SINGLE ORIFICE BUBBLER	8
PNEUMATIC FEATURES DUAL ORIFICE BUBBLER.....	9
CABLING	10
TERMINAL BLOCK.....	10
POWER CONNECTIONS.....	10
SDI-12 CONNECTIONS	10
DB9 CONNECTOR.....	11
RS-485 CONNECTOR	11
QUICK INSTALL.....	12
STANDALONE QUICK INSTALL	12
QUICK INSTALL WITH A LOGGER.....	12
SETUP AND OPERATION	13
PRINCIPLES OF BUBBLER OPERATION	13
PRESSURE MAINTENANCE.....	13
PURGE	14
BLOCKAGE DETECTION	15
LEAK TEST	15
STARTING THE BUBBLER.....	16
DUAL ORIFICE BUBBLER CONFIGURATION	16
ACCUBAR PRESSURE SENSOR.....	17
DQAP	25
WATER TEMPERATURE	27
SUSPENDED SEDIMENT.....	29
LOGGING.....	29
SD CARD INTERFACE.....	31
SETUP.....	32
CONNECTING BUBBLER TO A LOGGER	32
CONNECTING AN EXTERNAL SENSOR.....	32
BUBBLER TIME.....	33
BATTERY VOLTAGE	33
PASSWORD	34
PASSIVE SENSOR MODE	34
FLOW CALCULATIONS.....	34
PUMP WATCHDOG.....	34
FASTTRACK	35
FRONT PANEL INTERFACE	36
NAVIGATING THE MENUS.....	36
TURNING DISPLAY ON/OFF.....	36
CONTRAST.....	36
VIEWING CURRENT DATA.....	37
FRONT PANEL MENU TREE	38
SDI-12 SENSOR OPERATION	41
SDI-12 REFERENCE.....	41

RS232 COMMAND LINE INTERFACE.....	53
RS232 SETUP.....	53
MACHINE TO MACHINE COMMUNICATION.....	53
VIEWING WATER LEVEL.....	53
DOWNLOADING THE LOG.....	54
AUTO OUTPUT.....	55
RS232 COMMAND REFERENCE.....	55
SETUP TRANSFER VIA HYPERTERMINAL.....	60
CONNECTING A MODEM.....	60
RS-485.....	63
INSTALLATION.....	64
MOUNT THE ENCLOSURE.....	64
TUBING/ORIFICE INSTALLATION.....	64
ELECTRICAL CONNECTIONS.....	65
BUBBLER SETUP.....	65
CHECK FOR LEAKS.....	65
PURGE LINE.....	65
FIELD CALIBRATION.....	65
FACTORY CALIBRATION.....	66
HOSTILE CONDITIONS.....	66
TROUBLESHOOTING AND MAINTENANCE.....	68
TROUBLESHOOTING.....	68
HARDWARE ERROR CODES.....	70
MAINTENANCE.....	71
FIRMWARE UPGRADE.....	74
METHODS FOR UPGRADE:.....	74
GPS.....	76
TIMEKEEPING.....	76
GPS INSTALLATION AND SETUP.....	76
GPS POSITIONING.....	77
GPS OPERATION.....	77
GPS ERRORS.....	77
JUMPERS.....	77
RJ45 TO RS232 CONNECTOR.....	78
MODBUS.....	79
MODBUS MENU OPTIONS.....	79
MODBUS FUNCTION CODES.....	80
APPENDIX A – SPECIFICATIONS FOR THE BUBBLER.....	85
56-0133-XX SINGLE ORIFICE BUBBLER.....	85
56-0134-XX DUAL ORIFICE BUBBLER.....	86
WATER TEMPERATURE.....	87
APPENDIX B– SUTRON CUSTOMER SERVICE POLICY.....	89
APPENDIX C– COMMERCIAL WARRANTY.....	90
SUTRON MANUFACTURED EQUIPMENT.....	90
NON-SUTRON MANUFACTURED EQUIPMENT.....	90
REPAIR AND RETURN POLICY.....	90

EXTENDED WARRANTY AND ON-SITE MAINTENANCE.....90

Introduction

The Sutron Accubar ® Continuous Flow (CF) Bubble Gauge/Recorder (part number 56-0133-25-1) is a self-contained, precision device for measuring water levels. The device combines into a single package a pump, tank, manifold, control board, front panel (display and keypad), Accubar sensor, SDI-12 and RS232 interfaces, and enclosure for the purpose of measuring water levels using long established bubble gauge principles.

The Sutron Accubar ® Constant Flow (CF) **Dual Orifice** Bubble Gauge/Recorder (part numbers 56-0134-25-1, -2 and -3) is an enhanced version that is capable of providing redundant measurements, measuring water level in two separate bodies of water, accurately measuring water density, or providing an extended range of water level measurement.

The Accubar CF Bubbler is ideally suited for making water level measurements in rivers, streams, reservoirs, tidal, oceans and industrial areas.

The Bubbler is both a logger and a sensor. It is capable of operating standalone, or connected to another logger. In addition, the Bubbler can be used in conjunction with another water level pressure sensor.

The log inside Bubbler is capable of holding more than 300 000 readings, and allows the recording of status and water level data. The Bubbler has an SDI-12 interface as well as RS232/RS485 so it can provide data to data loggers or communications equipment.

A front panel allows the user to setup the operating parameters, monitor performance, perform tests, and examine the log.

The RS232 port supports a simple command line mode compatible with HyperTerminal and other communications programs. It allows full access to setup, status and data of the Bubbler. The interface makes it easy to connect the Bubbler to a modem or radio.

Features

- Self-contained needing only external power and outlet tubing
- Long-life desiccant (up to 1 year depending on local humidity and user set flow rate)
- User-settable bubble rate for varied field conditions
- Built-in, precision Accubar ® sensors with auto-zero for even higher accuracy
- Accuracy 0-20ft 0.01 ft, 20-57.5 ft. 0.05% reading.
- User-configured averaging to filter out waves.
- User-settable auto purge to keep the outlet clear of debris
- User-settable measurement and logging
- Built-in Flash log for 300,000 readings
- Stand-alone operation or operation with other loggers/communications via SDI-12, RS232 and RS485.
- Swing-out panel for easy maintenance.
- Front panel allows full access to setup, status and data
- Provides redundant data storage when connected to a logger
- FastTrack mode to improve operation at locations where the level changes rapidly
- NEW: DQAP processing of water level data

Dual Orifice Bubbler

The Sutron Accubar® Constant Flow (CF) Dual Orifice Bubble Gauge/Recorder (part numbers 56-0134-25-1, -2 and -3) is an enhanced version that is capable of providing redundant measurements, measuring water level in two separate bodies of water, accurately measuring water density, or providing an extended range of water level measurement.

The Dual Orifice Bubbler can do everything that the single Bubbler can and more.

The most obvious difference between the single and dual orifice units is that the Dual Orifice Bubbler can maintain pressure in **two** lines. Internally, the Dual Bubbler is equipped with an additional tank, an additional restrictor pressure sensor, an enhanced manifold, and an optional second Accubar® sensor.

Sutron offers four versions of the Dual Orifice Bubbler:

- **56-0134-25-1** Accubar Constant Flow, Dual Orifice Bubbler Gauge/Recorder with single Accubar® sensor rated to 25psi.
- **56-0134-25-2** Accubar Constant Flow, Dual Orifice Bubbler Gauge/Recorder with dual Accubar® sensors rated to 25psi.
- **56-0134-25-3** Accubar Constant Flow, Dual Orifice Bubbler Gauge/Recorder with one Accubar® water level sensor and one Accubar® water density sensor
- **56-0134-50-2** Accubar Constant Flow, Dual Orifice Bubbler Gauge/Recorder with dual Accubar® sensors rated to 50psi.

The -1 and -2 versions can make separate measurements in two locations. The device monitors and manages the pressure on each orifice line independently of the other so that pressures in one line do not affect the operation of the other line. They can be used to make measurements in separate channels or bodies of water or within the same area as redundant sensors. The sensors can even be installed in a vertical orientation to provide an extended range measurement with up to 50 PSI total range.

The -25-1 version with a single sensor switches the sensor between the two lines when measurements are made. The switch in lines causes a delay of up to a minute to allow the pressures in the lines to settle.

The -25-2 version adds to the -25-1 an additional Accubar® sensor to eliminate the need to switch between lines. Each line can be measured simultaneously.

The -25-3 version adds to the -25-1 a special Accubar® sensor gauge to accurately measure the density. This sensor is 3 times more accurate at measuring density than it is to measure it using separate precision sensors.

The -50-2 version is just like the -25-2 but with Accubar® sensor rated to 50psi. This allows for measurements at greater depths and obsoletes the extended range configuration of the 25psi versions.

Dual Orifice Bubbler Additional Features

- User-settable bubble rate for varied field conditions, separate for each line
- User-set configuration for single, dual orifice lines and extended range operation (-1, -2 only)
- Built-in, precision dual Accubar® sensors (-2 and -3 only)
- Density measurement with 0.1% accuracy (-3 only)

Unpacking

Remove the Bubbler from the shipping container and visually inspect the unit for signs of damage during shipment. Report any such damage to the factory immediately to ensure a prompt response and resolution. Retain one shipping container in the event a factory return is necessary.

Please note that if a return is required, a return material authorization (RMA) number is required. To get this RMA number, call the Sutron Customer Service Department at 703 406 2800.

Pneumatic Features Single Orifice Bubbler

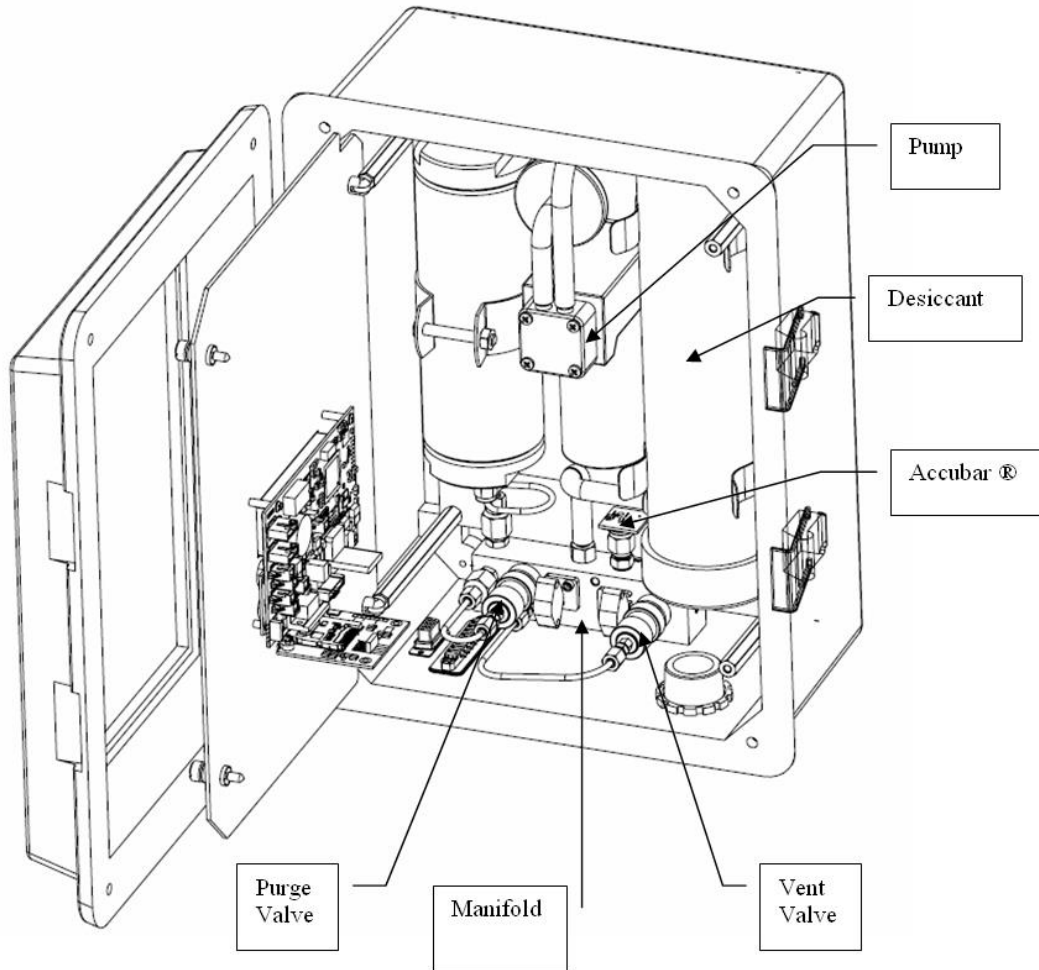

Pneumatic Features Dual Orifice Bubbler

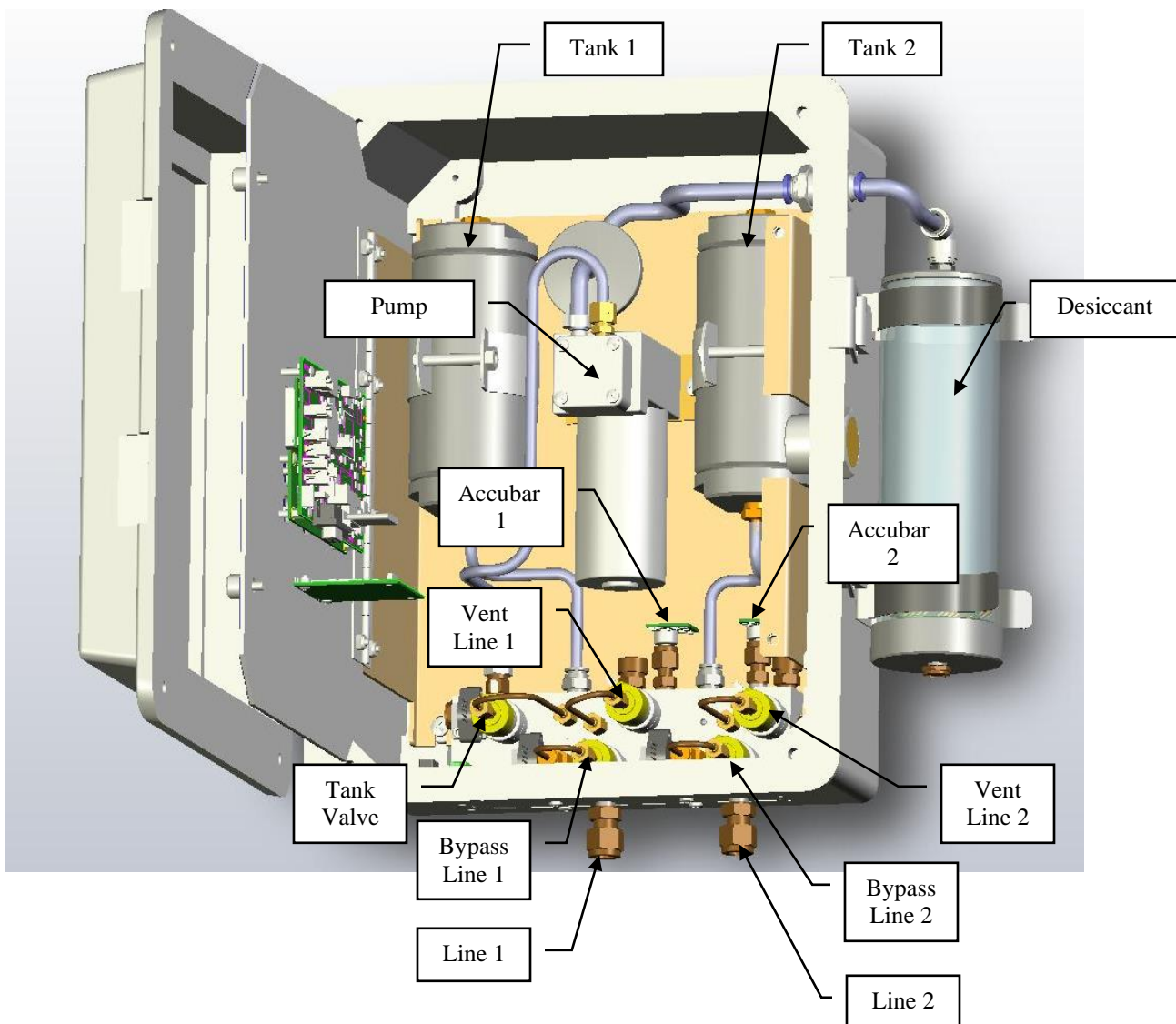

Cabling

Terminal Block

Terminal Block	Description	Notes
1	Earth	Earth
2	DATA	SDI-12
3	N/C	NOT USED
4	GND	SDI-12
5	RS485 A	RS485 A
6	RS485 B	RS485 B
7	+12V	Power 12V (4 amps)
8	GND	Power Ground



Power Connections

The CF Bubbler requires external +12V power to operate. The most common power source for the Bubbler is a lead-acid battery. **Connect the battery to pins 7 and 8 of the external terminal strip.** Use wire that is at least 20 gauge and no longer than 5 feet. If you need longer wires to the battery, use a lower gauge wire. Make sure the power connections (7 and 8) go straight to the battery.

When using the CF Bubbler with a Satlink or other telemetry device, be sure to still connect the battery directly to the Bubbler's power connections.

Note: you cannot connect the power to switched or protected voltages on most data loggers because the Bubbler uses too much power (around 4 amps at 12V) when it runs the pump.

For details on Bubbler [battery voltage](#) please refer to page 33.

SDI-12 Connections

The SDI-12 interface is a three wire interface with connections for GND, Power and Data. However, most SDI-12 interfaces on data recorders cannot provide the 4 amps power needed to operate the bubbler pump. Therefore, ***do not*** connect the bubbler to the logger SDI +12V. Bubbler GND (Terminal 8) and +12V (Terminal 7) ***must always*** be connected directly to a battery or other high current source. If there are two batteries/power sources in the system, the grounds of these systems ***must be*** connected together.

Connect the SDI Data line on the bubbler (pin 2) to the SDI Data line on the data logger. You may also connect the SDI GND line on the bubbler (pin 4) to the SDI GND line on the data recorder. The sensor is shipped to respond to SDI-12 address 0. The section [SDI-12 Sensor Operation](#) has details on the SDI-12 protocol and supported commands.

Note, if you are operating standalone, you do not need anything connected to the SDI-12 connections.

Some older bubblers labels Terminal 3 as SDI +12V. Do not use this connection. The bubbler should only be powered using terminals 7 and 8. Newer units have removed this labeling/wiring to avoid confusion when installing a unit.

DB9 Connector

The Bubbler comes with a DB9F connector for connection to RS-232 devices. The DB9F can be connected to the serial port on most PCs using a straight cable. A null modem adapter is needed to connect to most PDAs and [modems](#). There is a [command line interface](#) that allows communication via RS-232 (page 53).

The following table shows the pin assignments in the DB9F connector.

DB9F Pin	Name	Notes
1	N/C	No Connection
2	RXD	Data from CF Bubbler
3	TXD	Data to the CF Bubbler
4	DTR	Signal to the CF Bubbler
5	Ground	
6	DSR	Signal from unit, asserted as long as unit has power
7	RTS	Request to Send, signal to the CF Bubbler
8	CTS	Clear to Send, signal from the CF Bubbler
9	VOUT	Jumper J8 selectable for 5V (default) or VBAT (100ma max) - this line is usually NOT passed by a null modem

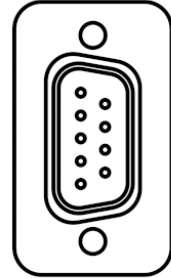

RS-485 Connector

The Bubbler can be interfaced to via RS485 A and RS485 B connections on the front panel using the SDI-12 protocol.

The Bubbler only supports the SDI-12 protocol over the RS485 connection. No settings need to be changed to use SDI-12 over RS-485. The Bubbler does not support connections over both the RS485 and the SDI-12 lines at the same time.

MODBUS over RS485 is NOT supported.

Quick Install

- [Mount the enclosure](#) vertically
- [Install](#) the orifice line(s) in the desired location(s)
- [Connect power](#)
- Do a [leak test](#)
- Connect orifice line(s) to bubbler and [Purge](#) the line(s)
- Customize settings:
 - Setup the [orifice configuration](#) (Dual Orifice Bubbler only)
 - Setup the [bubble rate](#)
 - Change station name
 - [Set the water level](#)
 - Set [level units](#)
 - Change [automeasure](#) schedule

For [complete installation details](#), please turn to page 63.

Standalone Quick Install

The Bubbler starts measuring and collecting data as soon as it is powered up. By default, the Bubbler will measure and log water level every 15 minutes; each reading is averaged for 10 seconds. All of these settings and more can be changed – please [refer to page](#) 24 to learn more about how the unit measures.

Quick Install with a Logger

Bubbler can be connected to other devices via either SDI-12, RS-485 and RS232.

- For SDI-12 operation, connect the SDI data line on the Bubbler to a SDI logger and setup the logger to periodically collect data from the sensor. The first parameter of the M! command will provide the water level. For more details on SDI-12, please refer to the [SDI-12 Sensor Operation](#) section of the manual.
- If connecting using the RS232 port, the data can be polled from the Bubbler, or it can be automatically output by the Bubbler. Setup the connected device (which may be a logger, a modem, or even a direct connection to a PC running HyperTerminal) for 115200 baud, 8 data bits, no parity (the baud rate can be changed via the front panel [Setup > Other Settings > Baud Rate](#)).
 - To poll for data, have the connected device issue a carriage return, wait for prompt, issue the ASCII command “![MEAS](#)” followed by a carriage return, and capture the returned data. The first data item returned is the water level.
 - To capture data, setup the Bubbler for *auto output* via the front panel [Setup->Other Settings->Auto Output](#). Once setup, the Bubbler will periodically output the water level in ASCII.

Please refer to the section [RS232 Command Line Interface](#) on page 53 for more details.

Redundant Data Collection

- Connect the Bubbler via SDI-12 to a logger and setup the logger to get data from the Bubbler.
- Provide a power supply to the Bubbler (via the Battery connector).
- With this setup, if the logger malfunctions, the Bubbler will keep on collecting data.

Setup and Operation

Principles of Bubbler Operation

The Accubar CF Bubble is ideally suited for making water level measurements in rivers, streams, reservoirs, tidal, oceans and industrial areas.

A bubble gauge operates by generating pressure in a line sufficient to produce bubbles out the end of tube placed in the water. When the rate of bubbles is sufficiently small, the pressure in the line is static so that the pressure at the orifice is the same as the pressure at the other end of the tube in the instrument itself. A sensor can then measure the pressure without having to install the sensor in the water.

Pressure Maintenance

Since air is always leaving the tank, the system will need to periodically operate the pump, just to keep the user pressures in the system balanced. Also, as the water level rises, the pump operates to balance the system at a higher pressure. As the water level goes down, the pump is not operated allowing the system to balance at a lower pressure as surplus air simply escapes through the line.

Bubble Rate

The bubble rate is the measure of the amount of air going down the orifice line per unit of time. The Sutron Bubbler supports two units for bubble rate: Bubbles per minute (BPM) and Standard Cubic Centimeters per Minute (SCCM). The higher the bubble rate, the more air will flow down the line.

The Bubbler rate can be configured by the user: use [Station Setup > Bubbler Setup > Bubble Rate](#), SDI -12 [XBF](#), or BUBBLE RATE command line.

The Dual Orifice Bubbler has two independent bubble rate settings, one for each line.

The correct bubble rate is station dependent.

- **Sites measuring a deeper water level will require a higher bubble rate.**

If the bubble rate is too low, the Bubbler will not be able to overcome the pressure exerted by the water onto the air in the orifice line. This will result in no bubbles going out and an erroneous water level reading.

A rapidly rising water level will not be immediately detected by the Bubbler. If a fast reaction time to water level changes is required, a higher bubble rate will be needed.

- **Sites with rapidly changing water levels will require a higher bubble rate.**

The higher the bubble rate, the more power the Bubbler will require.

The bubble rate for a site with slowly changing levels is typically 60 bubbles per minute out of a 1/8 ID tube. This corresponds to a flow of about 5 standard cubic centimeters per minute (SCCM). The main device in the CF bubbler that governs the flow is a flow restrictor installed in the manifold. This flow restrictor is designed to give a specific flow based on the differential pressure it sees. For example, if there is a differential of 5 PSI across the restrictor, the flow will be 6 SCCM. At 10 PSI, the flow will be 12 SCCM. The way the bubbler maintains the flow at the desired value is to monitor this differential pressure and increase the pressure when it falls out of limit. The bubbler does this by turning on a pump to add pressure to a tank.

The Dual Orifice Bubbler is equipped with two restrictor sensors and two tanks.

Note: the setting of the bubble rate is identical to how the bubble rate is set in conoflo type bubble gauges that have been used for many years.

Pump Run Time

The Bubbler tracks the cumulative pump on time. That is the total amount of time that the pump has been running. It is possible to reset the pump run time.

Both the single and the Dual Orifice Bubbler are equipped with a single pump. The Dual Orifice Bubbler has two tanks and operates a valve in order to select which tank is being filled by the pump.

To view the pump run time, go to [Diagnostic > Pump Run Time](#), or. To reset the pump run time, press SET when viewing it via front panel, or type `DIAGNOSTIC 0` via command line.

Bubbler Internal Sensors

The Bubbler uses several internal sensors to maintain pressure. There is a tank sensor, which measures the air pressure inside the tank, and a restrictor sensor, which measures the pressure drop across the internal restrictor. The sensors' upper limit is 72.5PSI (upper limit is 101PSI for 50psi units).

The Dual Orifice Bubbler is equipped with two restrictor sensors but only one tank sensor. Which tank's pressure is measured by the tank sensor is determined by the valve which selects what tank is being filled by the pump. Unlike the single Bubbler, the Dual Orifice Bubbler will not always be able to provide tank pressure to the user. If the Bubbler is busy filling tank 2, tank 1 pressure will be unavailable.

Tank pressure can be found on the top level of the front panel menu. Both restrictor and tank pressure can be seen on the [Diagnostic](#) menu, via [SDI-12 M8](#) and via [INTERNAL](#) command.

Purge

The purpose of the purge is to clear the orifice line of any obstructions, such as dirt and silt.

Purging turns on the pump and builds to *purge pressure* (default 50 PSI for 25PSI units/ 70PSI for 50PSI units) and then opens the restrictor bypass valve to force the pressurized air to the outlet. The pump will continue to run for *purge duration*, turn off, and allow the pressure to bleed out the line.

To change purge pressure and duration, go to [Station Setup > Bubbler Setup](#), or type `PURGE PRESSURE` and `PURGE DURATION` via command line.

To start a purge, use [Diagnostic > Purge](#), [SDI-12 M9](#), [PURGE NOW](#) command line.

The Dual Orifice Bubbler can purge each line independently. Purge information for each line is stored separately.

During a purge, the Accubar will not be able to measure water level. This is because the pressure in the orifice line is not caused by the water, but by the Bubbler itself. You may see missing Accubar data or data marked 'Reading old' during a purge.

AutoPurge

A purge may be done automatically by the Bubbler. It can be done periodically, whenever the Bubbler detects a blockage, and whenever initiated by the user.

If a Dual Orifice Bubbler is setup for an AutoPurge, it will purge line 1 first, and purge line 2 a short while afterwards. If a blockage is detected, only the blocked line will be purged.

If you would like for the Bubbler to periodically purge, enable *AutoPurge* ([Station Setup > Bubbler Setup > AutoPurge Enable](#) or type `AUTOPURGE ENABLE`). To tell the Bubbler how often to purge, use the *AutoPurge Interval* setting.

Blockage Detection

Blockage detection refers to the Bubbler's ability to automatically detect when the orifice line is blocked and initiate a purge, thus cleaning the line of the blockage. For example, if the line fills up with sand or silt, it could prevent the water level sensor from properly measuring the water level. The Bubbler can detect that condition and automatically purge the line of obstruction.

When the orifice line is blocked, the pressure inside the line will build up. Initially, the Bubbler will think that the water level is rising and compensate by increasing the tank pressure. If this continues, the pressure in the line will increase to its upper limit and the system will stop pumping in order not to overpressure. To prevent this scenario, make sure to enable Bubbler's *blockage detection*.

If you would like for the Bubbler to automatically detect blockage and purge, enable *Blockage Detection* ([Station Setup > Bubbler Setup > Blockage Detection](#) or type *BLOCKAGE DETECTION*). Also setup *Blocked Flow* and *Blocked Pressure*.

This is the algorithm that detects blockage: if the pressure across the Bubbler's internal restrictor pressure sensor is less than the user set *blocked flow*, and if the pressure in the orifice line is greater than *blocked pressure*, a blockage has occurred.

What this means is that if that the pressure inside the line (*blocked pressure*) is very high and the air flow through the line (*blocked flow*) is very low, the line is blocked.

Set *blocked pressure* to a value that is higher than the highest pressure that can be caused by the water level being measured. If the *blocked pressure* is set too high, the system may never reach that pressure because the system tries not to overpressure (it will not operate the pump if the pressure is too high).

Set *blocked flow* to a small value like 2PSI (which roughly corresponds to 2SCCM). The flow sensor is accurate to +/- 1PSI, and minimum flow is 5PSI (about 5SCCM). A small value indicates that not enough air is flowing through the line.

For example, if *blocked pressure* is 15PSI and *blocked flow* is 2PSI, a purge will occur if the pressure in the orifice line is greater than 15PSI and the flow is less 2PSI.

Please note that neither AutoPurge nor Blockage Detection can cause a purge more frequently than once an hour.

Whenever a line is detected as blocked the event *Line Blocked* will be logged, along with the line pressure at the time. Similarly, whenever the Bubbler decides the line has cleared, it will place a *Line Cleared* event into the log.

If a Dual Orifice Bubbler is setup for blockage detection, each line will be checked independently of the other. If a blockage is detected, only the blocked line will be purged. The note 'Line Blocked' refers to line 1. The note 'Line 2 Blocked' refers to line 2. Blockage detection *cannot* be enabled for only one of the two lines.

Leak Test

Leaks inside the Bubbler can be a source of inaccuracy and/or excessive pumping and use of desiccant. To check for leaks, you must cap the outlet or orifice and run the built-in leak test.

Sutron provides a cap with each unit that can be used to cap the outlet for the leak test. When the leak test completes, the system will display a status indicating whether the unit has passed or failed the leak test along with a score.

A Dual Orifice Bubbler can run leak tests on each line independently. Leak test information for each line is stored separately.

To start a leak test, use [Diagnostic > Leak Test](#), or [LEAK TEST](#) via command line.

Starting the Bubbler

The Bubbler starts operating as soon as power is applied. The display will turn on. If an Accubar is installed, measurement will commence and the front panel will be updated with a water level reading. While the bubbler is operating, the status LED will flash occasionally to let you know that the bubbler is operational.

Green LED	flashes every five seconds to indicate the Bubbler is operating normally
Red LED	flashes if the Bubbler has encountered a problem

Dual Orifice Bubbler Configuration

This section refers to the Dual Orifice Bubbler, which is an enhanced version of the CF Bubbler that is capable of providing redundant measurements, measuring water level in two separate bodies of water, accurately measuring water density, or providing an extended range of water level measurement.

The setting *Orifice Config* setting determines how the dual orifice bubbler behaves. The options are Single, Dual Separate, Dual Density, and Dual Expanded Range. It is paramount that this setting be configured properly for the station.

Please remember that the Dual Orifice Bubbler comes in three versions: -1 which has only one Accubar sensor installed, -2 which has two Accubar sensors for measuring water level, and -3 which has one sensor for water level and another for density. The -1 and -2 sensors can be configured for any *Orifice Config*. The -3 can only be used in Dual Density mode. Information about the second sensor (No Accubar Found, Stage, Density) can be found in the [Diagnostics](#) menu and via the [DIAG](#) command.

To setup *Orifice Config*, use [Station Setup > Dual Orifice Setup > Orifice Config](#), or [ORIFICE CONFIG](#) command.

Single

In this mode, the Dual Orifice Bubbler acts like a single Bubbler. Only line one is utilized, and some of the power of the unit is wasted. DQAP is available only in Single mode.

Dual Separate

The device monitors and manages the pressure on each orifice line independently of the other so that pressures in one line do not affect the operation of the other line. They can be used to make measurements in separate channels or bodies of water or within the same area as redundant sensors.

In this mode, Bubbler will produce [two water level readings](#) (see page 19). Stage 1 is measured in line one, and Stage 2 is measured in line 2.

Dual Density

This mode is used when the density of the water is of interest to the user. The Bubbler will compute density and use the result in the water level computation. Please see page 19 for more on [density](#).

In this mode, the tube endings have to be installed in a vertical configuration, with line 1 above line 2. Line 2 must be the deeper line for the system to operate properly. The distance between the tubes must not change if the density reading is to be correct. Please see page 19 for more on [Orifice Separation](#).

In Dual Density mode, stage is measured on line one.

Dual Expanded Range

In order to measure water deeper than the range of a single Accubar sensor (please see [specifications](#) on page 85), the Dual Orifice Bubbler can be put into dual expanded range mode. Expanded mode can offer up to twice the range of a single Accubar.

In this mode, tube connected to **line one is placed in shallower water**, and **line two in deeper water**. The basic principle is that the Bubbler will measure water level using line one in shallower water until that line is almost out of water. Once the water level drops, the Bubbler will use the sensor in line two which is in deeper water. If the water level were to rise such that the sensor in line two in deeper water were over-pressured, the Bubbler would switch to using the sensor in line one in shallower water.

Please note that in this mode, *the Bubbler will not make any measurements until the user sets the water level*. See page 20 for more details on [Dual Expanded](#) mode.

Accubar Pressure Sensor

The Accubar is a pressure sensor inside the Bubbler. It is used to measure the pressure in the orifice line. That pressure can be translated into a water level reading.

The true reading made by the Accubar is a differential pressure – the pressure difference between atmospheric pressure and pressure in the orifice line. The Accubar is a vented sensor.

Each Accubar sensor is calibrated independently of the Bubbler. On each Accubar there is a sensor, an analog to digital converter, and a secure chip containing the calibration data. Every Accubar has a unique sensor ID.

The Dual Orifice Bubbler may come equipped with two Accubar sensors. The -1 version of the Dual Orifice Bubbler comes with only one sensor. In order to measure pressure on both lines, the -1 Dual Orifice Bubbler needs to switch the single Accubar between the two lines. Every switch will cause a delay of up to one minute as the pressures in the system are equalized prior to the measurement.

The more capable -2 version of the Dual Orifice Bubbler has two Accubar sensors, each setup to measure pressure in its own line. It can make fast water level readings with fewer disturbances to the pressure in the lines.

The -3 version of the Dual Orifice Bubbler features an Accubar sensor built to measure density via the pressure differential between the two lines. Note that both the -1 and -2 versions of the Dual Orifice Bubbler can also measure density, but not with the accuracy of the -3 version.

To view the Accubar ID, use [Diagnostic > Accubar ID](#), [SDI-12 XAI](#), or [DIAGNOSTIC](#) via command line. If there is more than one Accubar in the system, use SDI-12's XAI2 command. Over command line and front panel, both Accubar IDs will show automatically. Additionally, the function of the second Accubar (Stage or Density) will also be displayed.

The Accubar is a plug and play part, meaning that it can be easily replaced without disturbing the rest of the Bubbler system.

Disabling the Accubar and water level measurements can only be accomplished by physically disconnecting the sensor from the board. Before you disconnect the Accubar, please consider the fact that the Accubar is a very low power device that does not interfere with the pressure maintenance of the Bubbler. Plus, the Accubar will provide water level data which may be of use if the external sensor fails.

Autozero

Even though the Accubar sensor is very accurate and stable, it still exhibits a small amount of drift in the "zero". A sensor's accuracy depends completely on the stability of the zero and span. Any error in the zero becomes an error in the final water level. Even though sensors are calibrated at the factory for zero, they all

drift and introduce error into the water level. The CF Bubbler Accubar features an autozero ability that eliminates the errors due to a drift in zero resulting in more accurate water level readings.

The Bubbler will automatically autozero the Accubar at the end of a purge. The autozero will take approximately half a minute to complete. During this time, the sensor is vented to the atmosphere so that both sides of the sensor are at identical atmospheric pressure. The Bubbler can be asked to do an autozero via command line, front panel or SDI-12. Bubbler software versions older than 1.30 featured an automatic autozero every 15 minutes.

To view the Accubar autozero, use SDI-12 [V](#), or [DIAGNOSTIC](#) via command line. If [Log Daily Values](#) is enabled, the autozero result will be logged every day.

There are several ways to access the water level reading *without* the autozero: diagnostic menu called [Accubar Pressure Diagnostic](#), two SDI-12 commands ([M1](#), [M2](#)), [Modbus](#) access. Additionally, if [Log Accubar Pressure](#) is enabled, the logged pressure does not include autozero.

Measuring Water Level (Stage)

The Bubbler uses the Accubar sensor to measure water level. If no Accubar is installed, the water level will not be measured. The water level is the first reading shown on the [front panel](#) when the station is powered up.

The Accubar is a pressure sensor. It will measure the difference between the pressure in the orifice line and atmospheric pressure. Water level is computed from that pressure difference. The Bubbler will take multiple Accubar samples and compute an averaged water level from them.

Quality of Measurement

If there is a problem when measuring, the quality of the water level will be bad. If using the front panel, a bad quality is indicated with a “?” [after the reading](#). Additional details on the error may be available (see below). The [command line interface](#) will say ‘error’ and indicate the type of problem, .SDI-12 will indicate an [invalid reading](#). The red LED will blink if the last reading is invalid.

Starting with version 1.35, some bad readings may show up as -999.9. This kind of reading indicates a complete failure to make a meaningful measurement. Sometimes, the unit will be able to salvage an imperfect reading and produce a reasonable result. For example, if fewer than the expected number of samples were averaged, or if the battery voltage were low, the result may still be representative of the water level. However, if the Accubar sensor failed to measure the pressure, -999.9 would be reported as the result.

Starting with version 1.37 additional error details will be provided by the Bubbler. If there was an error in the reading, one of the following will display on command line and front panel:

- **Sensor Failure** – this means that there is either a problem with the Accubar sensor or in the communications line leading to the sensor.
- **Battery Low** – the battery voltage was under an acceptable threshold. The reading may still be correct.
- **Missing Readings** – the system did not collect the expected number of samples when averaging a stage reading. In continuous mode, the first reading after power-on is likely to have missing readings.
- **Line out of water?** – Dual Orifice Bubbler in Density mode may log this error if one of the two lines was out of water (technically, pressure in either line was less than 0.1PSI)
- **Bad Orifice Spert?** – Dual Orifice Bubbler in Density mode may log this error if the computed density is out of range of 0.9 and 1.1gm/ml. This is most likely to the system having an incorrectly setup *Orifice Separation*. The *Orifice Separation* needs to be set to the exact distance between the two lines. It can be computed by the system if the user knows the exact density of water.

Right after power up, while the Bubbler is still computing the first reading, the message ‘calculating’ will show on the front panel and command line interface. Please give the Bubbler a minute after power up to get going.

If the *Sensor Failure* is reported repeatedly, it is most likely due to failure of the Accubar sensor. In this case, the Accubar sensor may need to be [replaced](#) (see page 73).

The Dual Orifice Bubbler may be setup to produce [two water level](#) measurements – please see the section below.

Setting the Water Level

To see the water level, use the first menu shown on the [front panel](#); Via command line, use the [MEAS](#) command. Via SDI-12, use the [M command](#). If a Dual Orifice Bubbler is setup to produce two water level readings, each of the interface points just mentioned will provide the second water level reading. The front panel will provide ‘stage’ and ‘stage 2’ readings. If setup for density, the front panel will show a ‘density’ reading. The SDI-12 M and command line MEAS command will return more parameters relevant to the second reading.

Dual Orifice Bubbler Second Measurement

The Dual Orifice Bubbler may produce two readings. If [Orifice Config](#) is setup as *Dual Separate*, then Bubbler will produce two water level readings. If it is setup as *Dual Density*, Bubbler will produce one water level and one density reading.

If setup for two water level readings, the reading for line one will be labeled *stage* and the water level reading for line two will be *stage2*. If the *measurement name* has been changed from *stage*, then the second reading’s name will have ‘2’ appended to it, e.g. if *measurement name* is ‘water’ the second reading will be displayed and logged as ‘water2’.

Stage is measured in line one, and Stage 2 is measured in line two.

Please note that you may *not* setup the Bubbler to make two stage readings and a density reading.

Dual Orifice Bubbler Density

In [Orifice Config](#) *Dual Density* mode, in addition to measuring the water level in line one, the Bubbler will measure the density of water. The resultant density will be used to modify the water level reading. Density will be shown on the [front panel](#) and placed into the log. It may also be accessed via SDI-12 and command line.

In this mode, the tube endings have to be installed in a vertical configuration, with line 1 above line 2. Line 2 must be the deeper line. Stage is measured on line one while the density is measured by the differential pressure of line 1 and line 2. Please see the [installation section](#) on page 63 for more details.

Dual Orifice Bubbler has settings called *Orifice Separation* and *Separation Units*. *Orifice Separation* is the exact vertical distance between the two tube endings. The Bubbler will need to be told either the *Orifice Separation* or the current density in order to produce correct water level and density readings.

Density is computed based upon the measured pressure difference between the two orifice lines and the user settings *Orifice Separation* and *Separation Units*. Density is reported in units of gm/ml.

$$\text{Density} = (\text{Pressure Difference}) / (\text{Orifice Separation in feet}) * 2.3066587$$

Once computed, the resultant density will be included in the computation of water level.

$$\text{Water Level in feet} = (\text{Accubar Pressure in PSI} * 2.3066587) / \text{Density} \\ + \text{ [Field Calibration Offset](#) }$$

Calibrating Density

The Bubbler can help determine the correct *Orifice Separation*:

- While viewing a live density reading on the front panel, press SET.

- If your Bubbler is equipped to measure [water temperature](#), it will ask if the lines are in pure water. If so, the Bubbler can correctly determine the density based on water temperature, and it can compute the exact *Orifice Separation*.
- Alternatively, the correct density can be entered via the front panel, and the Bubbler will use that value to compute and set the *Orifice Separation*.
- Via command line, type DENSITY = 1 to set Density to 1. If your Bubbler can measure water temperature and the lines are in pure water, type DENSITY = PURE.

The -3 version of the Dual Orifice Bubbler features an Accubar sensor dedicated to measuring density. Note that both the -1 and -2 versions of the Dual Orifice Bubbler can also be setup measure density, but not with the accuracy of the -3 version. Please note that you may *not* setup the Bubbler to make two stage readings and a density reading.

Density readings are only valid if the resultant density is between 0.9 and 2.0 gm/ml. Additionally, the pressure in each line must be at least 0.1 PSI. If these conditions are not met, the Bubbler will log a 'Out of Range' error with each density reading. The front panel and command line interfaces will indicate the error.

Separation Units are units of length (feet, inches, meters, centimeters, or millimeters). They tell what units *Orifice Separation* is expressed in. Changing the *Separation Units* will not automatically change the *Orifice Separation*.

To set the density via front panel, power up the Bubbler, press the DOWN key until the density reading is shown, and then press SET. Enter the correct density and press set again. The system will use the entered value to compute the Orifice Separation. It is also possible to use SDI-12 [XS command](#) and command line [DENSITY](#) to set the density.

Optionally, one may access Orifice Separation and Separation Units directly via via [Station Setup > Dual Orifice Setup](#), via SDI-12 [XE](#), or via ORIFICE SEPARATION and SEPARATION UNITS commands.

New Log Entry Error

Please note a new log entry error: Out of range – Dual Orifice Bubbler in Density will LOG this error for either of these conditions:

- One of the two lines was out of water (technically, pressure in either line was less than 0.1PSI)
- If the computed density is in out of range of 0.9 and 2.0gm/ml. This is most likely to the system having an incorrectly setup Orifice Separation.

If your Dual Orifice Bubbler is equipped to measure water temperature, please make sure to read the section on [water temperature](#) and [suspended sediment](#).

Dual Orifice Bubbler Expanded Range Mode

In order to measure water deeper than the range of a single Accubar sensor (please see [specifications](#) on page 85), the Dual Orifice Bubbler can be put into dual expanded range mode. Expanded mode can offer up to twice the range of a single Accubar.

In this mode, tube connected to **line one is placed in shallower water**, and **line two in deeper water**. The basic principle is that the Bubbler will measure water level using line one in shallower water until that line is almost out of water. Once the water level drops, the Bubbler will use the sensor in line two which is in deeper water. If the water level were to rise such that the sensor in line two in deeper water were over-pressured, the Bubbler would switch to using the sensor in line one in shallower water. Please see the [installation section](#) on page 63 for more details.

Please note that in this mode, ***the Bubbler will not make any measurements until the user sets the water level.*** Read on for detail on how to setup the station.

Consider this example

- A lake has a high water level line of 80 feet. A standard 25PSI Accubar (see [specifications](#)) can measure up to 57 feet of water. In order to measure the full water level, a Dual Orifice Bubbler needs to be installed.
- **Line one has been placed at the 50 foot water line.** Without the filed calibration offset, line one would provide a reading of 30 feet when the water line is at the maximum of 80 feet, and a reading of 0 feet when the water line drops below 50 feet.
- Line one needs to have its **field calibration offset set to 50 feet**, indicating that whatever water level it measures it needs to add 50 feet to it. Line 1 will be able to measure the water level until it drops below 50 feet at which point the line would be physically out of the water.
- **Line two has been placed at the bottom of the lake.** In this setup, the line needs **no offset** (field cal 2 = 0). However, since a standard 25PSI Accubar can only measure up to 57 feet of water, it will not be able to provide a reading once the water level reaches 57 feet.
- The Dual Orifice Bubbler will automatically switch from using line one to using line two once the **water level drops below about 52 feet.**
- As the water level rises **above about 55 feet**, the Dual Orifice Bubbler will automatically switch from using line two to using line one.
- When the water level is between 50 and 57 feet, either line can make the measurement. When it is above 57 feet, it is too deep for line two, and when it is below 50 feet, line one is in the air and above the water line.

If the pressure for line one in shallower water **drops below 1PSI**, the system will switch to using line two in deeper water. One PSI is roughly equivalent to 2.3 feet of water.

The Bubbler will measure the water in line two in deeper water until the pressure is greater than the line switch limit. After reaching the line switch limit, the system will switch to using line one in shallower water.

$$\text{Line Switch Limit PSI} = 2\text{PSI} +$$

$$\text{Absolute value}(\text{Field Calibration Offset PSI} - \text{Field Cal 2 PSI})$$

A line switch may be initiated whenever any water level measurement is made. If the measurement does cause a line switch, the *next* measurement will be made in the line switched to. Each switch will be accompanied by a log entry *Line Switch* that will indicate the line switched to.

Active Line

The line that is currently being used by the Bubbler to measure the water level is referred to as the active line. The front panel and the command line interface will indicate which line is currently active.

On the front panel, the main stage menu will show the active line after the stage reading; e.g.

Stage (line 1)

10.1ft

On the command line interface, type [STATUS](#) and the system will report the active line.

The front panel will also indicate details on the inactive line. Shown right below the stage menu, the inactive line menu shows the pressure in the inactive line, as measured using the restrictor and tank pressure sensors. These sensors are far less accurate than the Accubar. Please note that this reading will not be possible during a purge or other similar line pressure disturbance.

If the line pressure computed is not too high to be measured by the Accubar, the user can press SET to switch the currently active line, which will result in the Accubar measuring the water level in that line. After the user initiates a line switch, the system will not do another line switch for three minutes. After the three minutes are up, the system will line switch only if the normal criteria described previously are met.

How does the Bubbler know which line is in deeper water? It needs the help of the user. The field calibration offset of the shallower line should be setup to be greater than that of the deeper line.

Bringing the Benefits of Real-Time Data Collection to the World

Sutron Corporation, 22400 Davis Drive, Sterling, Virginia 20164

Pressure is maintained in both lines at all times.
Accubar sensors are protected by a relief valve from excessive pressure.
The Bubbler will switch the Accubar out of line to prevent it from being exposed to excessive pressure.

No line switch will occur if a line is blocked (which can happen only if [Blockage Detection](#) is enabled).
The system will produce only one water level reading in expanded mode.

Setting Water Level in Dual Expanded Range Mode

The Bubbler will not measure the water level until it has been calibrated in Dual Expanded Range mode. It is mandatory that the user go through the process of setting the water level after installation.

To set the water level via front panel, power up the Bubbler, and see the message Stage Not Set. Press SET. Enter the correct water level for line one and press SET again. The system will inform you of the computed field calibration offset. Next, enter the stage for line two and press SET. The system will show the new offset for line two.

- *If either line is too deep for the Accubar sensor, the system will ask for a [field calibration offset](#) instead of the water level.*
- *If the line is above the water level, enter the level of the water at the point where the line is installed.*

It is also possible to use SDI-12 [XS command](#) and command line [LEVEL 1 and LEVEL 2](#) to set the water level.

An alternative way of calibrating the station, is to change the [field calibration offset](#) directly. You must change the offset for *both* lines before the system will start collecting water level data.

Measurement Name

The reading made by the Bubbler is that of water level. This manual refers to the reading as ‘water level’
There is a setting called *measurement name* that allows the user to name the reading something else, such as ‘stage’.

The user chosen name will appear in the log, on the front panel, and via the command line interface.

Measurement name can be viewed and changed via [Station Setup > Accubar Setup](#) or via the [MEASUREMENT NAME](#) command line.

The Dual Orifice Bubbler may produce two water level readings. To differentiate the two, the number 2 is appended to the user set name. If ‘stage’ was the user chosen name, then the readings will be labeled ‘stage’ and ‘stage2’.

Setting Water Level

When the Bubbler is first installed, it will display an absolute water level based on the water pressure. The user will then typically read the current water level off a staff gauge and then set this level into the Bubbler.

To set the water level via front panel, power up the Bubbler, wait for it to show a water level reading, and the press SET. Enter the correct water level and press set again. It is also possible to use SDI-12 [XS command](#) and command line [LEVEL](#) to set the water level. Dual Orifice Bubbler supports the LEVEL 2 command.

For more details on setting the density for the Dual Orifice Bubbler in [Dual Density](#) mode, please see the section on page 19. [Dual Expanded](#) mode is detailed on page 20.

Field Calibration Offset

Water Level = Accubar reading in chosen units + [Field Calibration Offset](#)

The field calibration offset can be viewed and changed via [Station Setup > Accubar Setup](#), via SDI-12 [XE](#), or via [FIELD CAL OFFSET](#) command.

The Dual Orifice Bubbler can be placed into *Dual Separate* or into *Dual Expanded Range* mode. In those cases, each line will have its own field calibration offset. The offset for the second line can be accessed in the same way as the offset for the first line: front panel, SDI-12, and the command line.

Level Units

Bubbler can report water level readings in feet, PSI, kPa, centimeters, meters, millimeters, or user units.

$$\text{Water Level} = \text{Accubar reading in chosen units} + \text{Field Calibration Offset}$$

To change level units, use [Station Setup > Accubar Setup > Level Units](#), SDI-12 [XUP](#), or *LEVEL UNITS* command.

User units are defined using the fields User slope and user offset. If user units are chosen:

$$\text{Water Level} = (\text{Accubar reading in PSI} * \text{user slope}) + \text{user offset} + \text{Field Calibration Offset}$$

To change user slope and offset, use [Station Setup > Accubar Setup > User Slope](#), SDI-12 [XUU](#), or *USER SLOPE* and *USER OFFSET* commands.

The Dual Orifice Bubbler will use the same units for both level readings.

Right Digits

The number of digits shown after the decimal place is referred to as the right digits. If you would like the water level to read 10.12 rather than 10.12345, please set the right digits to 2.

To change right digits, use [Station Setup > Accubar Setup > Right Digits](#), SDI-12 [XUP](#), or *RIGHT DIGITS* command.

The Dual Orifice Bubbler will use the same right digits for both level readings.

Log Temp in Box

The Accubar sensor has an internal temperature sensor. Please keep in mind that this is the temperature inside the Bubbler which is not the same as the temperature outside. The temperature is displayed in user's choice of Celsius or Fahrenheit. Temperature may be logged along with stage.

To view Accubar temperature, use [Diagnostic > Accubar w/o offset](#), SDI-12 [M6](#), or use the [MEAS](#) command. To change Accubar temperature units, use [Station Setup > Accubar Setup](#), SDI-12 [XUT](#), or *TEMP UNITS* command. To enable logging temperature, use the [Station Setup > Accubar Setup](#) menu.

The Dual Orifice Bubbler may come equipped with two Accubar sensors. While it is meaningful to report two water level readings, it is not useful to have two readings of the temperature inside the Bubbler. Most reported temperature readings will be from the first Accubar sensor. That being said, the temperature of the second sensor can still be viewed diagnostic purposes: use [Diagnostic > Accubar w/o offset](#), SDI-12 [M6](#).

Automeasure

Automeasure refers to the Bubbler's ability to automatically measure and log water level data. The user can determine when this will occur by changing the *automeasure interval and time*. Automeasure may not be turned off.

Automeasure time and interval determine when the Bubbler measures and logs data.

In Normal mode (see Operating Modes below), this is when the Bubbler measures and logs data:

- *E.g. Automeasure time 00:00:00 interval 00:10:00*
 - 00:10:00 data measured and logged
 - 00:20:00 data measured and logged
 - 00:30:00 data measured and logged
 - and every ten minutes afterwards...
- *E.g. Automeasure time 00:00:30 interval 00:05:00*
 - 00:00:30 data measured and logged
 - 00:05:30 data measured and logged
 - 00:10:30 data measured and logged
 - and every five minutes afterwards...

In Continuous and DQAP modes (see Operating Mode below), the Bubbler is continuously collecting sensor data. When the automeasure time comes, the Bubbler immediately computes the water level and other data based on the previously collected sensor data.

To change automeasure interval and time, use [Station Setup > Accubar Setup](#), or `AUTOMEASURE INTERVAL` and `ATUOMEASURE TIME` commands.

The last measurement made by automeasure is called [last automeasured](#)– please see page 25.

Operating Mode

There are several operating modes: normal, continuous, and DQAP

- In **normal mode**, Bubbler spends its time in low power mode until it is time to measure. Once the measurement is complete, Bubbler goes back to low power mode. This is the most commonly used mode and is recommended unless the Bubbler will be measuring very frequently.
- In **continuous mode**, Bubbler is constantly collecting data. When it is time to measure, Bubbler will use the previously collected data to instantly come up with a water level reading. Bubbler does not go into low power in continuous mode. The continuous mode adds about 10 mA to the quiescent power consumption compared with 0.25mA in the normal mode.
- **DQAP mode** uses a data processing algorithm used to filter outliers, resulting in a water level reading that excludes some disturbances to the water surface, such as waves. Just like continuous mode, DQAP mode results in constant data collection and increased power consumption. DQAP is generally collected over a period of six minutes. More info can be found in the [DQAP section](#).

These examples illustrate the difference between continuous and normal modes:

Normal mode with 10 second averaging:

1. 12:00:00 measure command is received (via SDI-12, front panel, RS232, or automeasure)
2. 12:00:00 sensors are powered on and measurement starts
3. 12:00:11 measurement completes with data collected between 12:00:00 and 12:00:10
4. 12:00:11 data is logged with a timestamp of 12:00:00
5. 12:00:11 sensors are powered down

Continuous and DQAP modes with 10 second averaging (sensors are powered on all the time):

1. 12:00:00 measure command is received (via SDI-12, front panel, RS232, or automeasure)
2. 12:00:00 measurement completes with data collected from 11:59:50 to 12:00:00
3. Data is logged with a timestamp of 12:00:00

Desired Effect	Appropriate Mode
-----------------------	-------------------------

Low power consumption	Normal mode
Low power consumption and immediately ready data	Normal mode, use last measured readings (page 25)
Immediately ready and current data	Continuous mode
Very frequent measurements (every 15 seconds or less)	Continuous mode
Filtering of sensor data	DQAP

Operating mode can be changed via front panel [Station Setup > Accubar Setup](#), via SDI-12 [XOM](#) and via OPERATING MODE command line

Averaging Time

Every time the Bubbler measures it will collect samples for a user defined period in order to produce a water level reading: this time period is called the averaging time. The setup variable *avg time* controls the averaging time. It is not possible to specify a number of samples, only the averaging time.

For continuous and DQAP modes, averaging time will determine how many samples will be used when computing water level results.

For [DQAP](#), it is recommended to use an averaging time of three or six minutes.

Averaging time can be changed via front panel [Station Setup > Accubar Setup](#), via SDI-12 [XT](#), and via [AVG TIME](#) command line.

Last Automeasured

Water level measurements made by the Bubbler are not instantaneous; how long they take depends on [averaging time](#) (page 25). When a logger is communicating with the Bubbler, it can ask the Bubbler to make a new measurement. However, the logger then has to wait for the Bubbler to complete the measurement.

If the user desires data that is instantly available, the Bubbler provides last measured data. The Bubbler automatically measures based on the [automeasure](#) interval (see page 24) . That data can be retrieved as the last measured data.

For example, **in Normal Operating Mode**, if Bubbler is setup to automeasure every 10 minutes, with an averaging time of 10 seconds:

12:00:00 to 12:00:10 Bubbler measures water level
12:01:00 logger asks for last measured data; Bubbler immediately returns 12:00:10 data
12:10:00 to 12:10:10 Bubbler measures water level
12:11:00 logger asks for last measured data; Bubbler immediately returns 12:10:10 data

If the user desires data that is both immediately available and current, [continuous mode](#) (page 24) is the way to go.

Last measured data can be accessed via [SDI-12 M3](#) and via [LAST](#) command.

DQAP

NOAA Data Quality and Assurance Procedure is abbreviated as DQAP. DQAP is an algorithm used to process samples into a final water level reading. The algorithm may be used to filter out wave action and other effects that disturb water level measurements. DQAP also provides a means of assessing the quality of the water level reading.

To use DQAP, please select it as the [Operating Mode](#).

Note that Dual Orifice Bubbler support DQAP only if [Orifice Config](#) is set to Single Mode.

DQAP Sampling

In DQAP mode, the Bubbler is continuously collecting Accubar water level samples. The samples are collected at the rate of one sample per second or slower, depending on the [averaging time](#).

Averaging Time	Sampling rate
3 minutes or less	One sample per second
6 minutes	One sample every two seconds
9 minutes	One sample every three seconds
12 minutes	One sample every four seconds
15 minutes	One sample every five seconds

Please note that during certain operations, such as a purge, the Bubbler will not be able to collect a sample. In those situations, fewer samples will be used in the DQAP algorithm.

If the Bubbler has collected fewer than 50% of expected samples, the flag “missing samples” will be set, but the water level results will still be computed.

Typically, an [averaging time](#) of three or six minutes is used. Shorter times may not produce enough samples for a meaningful result.

Log DQAP Samples

Normally, each sample is logged with the label “DQAP Sample”. This may result in the log being filled prematurely. Sampling once a second, the log will fill in less than four days. Consider using an [SD card](#) to expand the log capacity.

Logging each sample may be disabled via the setting *Log DQAP Samples* which may be found in the Other settings menu.

DQAP Algorithm

The DQAP algorithm involves two computations. In the first computation:

- The mean (average) and standard deviation of all the samples are calculated.
- Two limits are calculated: the mean plus/minus three times the standard deviation.
- Each sample is then compared against the two limits.
- If the sample is outside the limits, it will not be used in the final computation. That sample is an **outlier**. This value is logged as “Outliers”.
- If the sample is within limits, it will be used in the final computation. That sample is a **keeper**. This value is logged as “Keepers”. The second computation will be performed over the keeper samples.
- The sum of Outliers and Keepers is the total number of samples collected.

In the second computation:

- The mean (average) and standard deviation are recomputed from all the keeper samples.
- The mean is the resulting water level reading, typically logged as “Stage”
- The standard deviation is logged as “StdDev”. If this value is high, it indicates the water level reading is of poor quality.

Example of DQAP logged data

```

.. 175 DQAP Samples not shown
03/07/2023,18:11:52,DQAP Sample,0.452
03/07/2023,18:11:54,DQAP Sample,0.443
03/07/2023,18:11:56,DQAP Sample,0.458
03/07/2023,18:11:58,DQAP Sample,0.442
03/07/2023,18:12:00,DQAP Sample,0.457
03/07/2023,18:12:00,Stage,0.448,feet
03/07/2023,18:12:00,StdDev,0.006
03/07/2023,18:12:00,Keepers,180
03/07/2023,18:12:00,Outliers,0

```

The results of the DQAP computation are:

- Stage
- StdDev
- Keepers
- Outliers

All four of these values are always logged. Additionally, these values may be accessed via [SDI-12 M and M3](#), via [command line](#) as *MEAS* and *LAST*, and via [Modbus registers](#).

DQAP Averaging

In addition to the DQAP algorithm, if the Bubbler is in DQAP mode, it will provide several additional values:

- 15 second average
- 60 second average

These averages are computed over the samples collected during the specified time frame. They are the sum of the samples divided by the number of samples. These averages are computed independently of the DQAP algorithm.

Please note that, if the system is collecting samples every two seconds, there will be seven samples in the 15 second average.

These averages are not logged. They may only be accessed via [SDI-12 M7](#), via [command line](#) as *AVG*, and via [Modbus registers](#).

Water Temperature

Certain models of the Bubbler are capable of measuring a water temperature sensor. Such Bubblers will have an external five pin connector that the sensor can be wired to. Thermistor and Platinum RTD type sensors can be connected to the Bubbler.

If a Bubbler is equipped with the hardware for measuring a water temperature sensor, it will automatically measure and log water temperature every time it measures water level.

Live water temperature readings will be shown on the front panel. After turning on the front panel, press DOWN until the Water Temp menu shows. Additionally, the water temperature can be accessed via [SDI-12 M4 and M5](#) and [command line](#). All settings relating to water temperature can be found via the front panel in [Station Setup > Water Temp Setup](#).

- If the Bubbler is not equipped for measuring water temperature, no front panel menus relating to water temperature will appear.
- To disable water temperature readings, please use the *Water Temp Enable* setting. It is not enough to just disconnect the water temperature sensor!
- Water temperature may be used in the computation of [suspended sediment](#).
- It takes the Bubbler about one second to measure water temperature, adding to the total amount of time required to produce a water level reading.

Water temperature readings are logged with the *Water Temp* label. Water temperature can be reported in Celsius or Fahrenheit units, as dictated by the *Temp Units* setting.

Water Temperature Sensors

Two main types of water temperature sensors can be connected to the Bubbler:

- Platinum RTD
- NTC Thermistor

After wiring the sensor, make sure to tell the Bubbler what kind of sensor it is via the *Water Temp Type* setting. The following options are available:

- Platinum 385
- Platinum 392
- Platinum Custom
- NTC Thermistor

Platinum RTD

If *Platinum 385* or *Platinum 392* are chosen as the *Water Temp Type*, no further setup is needed. If *Platinum Custom* is chosen, then the coefficients *C0*, *C1*, and *C2* need to be entered. The following equation tells how temperature is computed

$$T = C0 - \sqrt{C1 + C2 \frac{R}{R0}}$$

T is the temperature in Celsius.

C0, *C1*, and *C2* are the coefficients and they are sensor dependent. These are Bubbler setup variables.

R is the resistance of the sensor element in Ohms which is measured by the Bubbler.

R0 is the resistance of the sensor at 0 degrees Celsius. It is also a Bubbler setup variable. It is traditionally 100 Ohms. When the temperature is calibrated, this value is affected.

The table below describes the coefficients used by the predefined *Water Temp Type*:

	Coefficient	Platinum 385	Platinum 392
<i>C0</i>		3383.8095	3389.7946
<i>C1</i>		13181769	13194682
<i>C2</i>		-1731602	-1703975

NTC Thermistor

For NTC Thermistor sensor types, the Steinhart–Hart equation coefficients need to be entered. Temperature is computed using this equation:

$$\frac{1}{T} = A + B \ln(R) + C(\ln(R))^3$$

T is the temperature in Kelvins.

R is the resistance of the sensor element in Ohms which is measured by the Bubbler.

A, B, and C are the coefficients. The Bubbler refers to them as *Stein A*, *Stein B*, and *Stein C*.

Water Temperature Sensor Wiring

The connector wiring pins are as follows:

1. Earth Ground
2. Force-
3. Sense-
4. Sense+
5. Force+

Two Wire Sensor

Connect sensor leads to positions 3 & 4. Use two short pieces of wire to jumper position 2 to 3 and 4 to 5.

Four Wire Sensor

Connect sensor GND and Sense- to positions 2 & 3 respectively. Connect sensor Sense+ and V+ to positions 4 & 5 respectively.

Calibrating Water Temperature Sensors

The easiest way to calibrate the water temperature sensor is via the front panel. First, navigate to the menu that says *Water Temp*. Press SET, and then enter the correct temperature reading.

Density Computed From Water Temperature

The density of water can be computed as a function of water temperature using the equation below:

$$\text{density} = 1000 \left(1 - \frac{T + 288.9414}{508929.2 * (T + 68.12963)} (T - 3.9863)^2 \right)$$

density is the density of water as a function of temperature in kg/m³

T = temperature in C

The Bubbler calls this value Density Temp and it can be accessed via the [DIAG](#) command, via the [Diagnostic front panel menu](#), and via the [SDI-12 M4 and M5](#) commands.

Suspended Sediment

A -3 dual orifice Bubbler with a water density sensor and a water temperature sensor will automatically compute suspended sediment. Suspended sediment is computed as a function of measured water density and water temperature.

A live reading of suspended sediment is shown on the front panel. Press DOWN several times until a menu labeled Suspended Sediment shows up. [SDI-12 M4 and M5](#) commands can be used to access the suspended sediment measurement. On the [command line](#)., MEAS and LAST commands will show suspended sediment readings along with the rest of water data. Alternatively, type [SUSPENDED MEASUREMENT](#) on the command line.

- The Bubbler expresses suspended sediment in units of mg/L.
- Suspended sediment will be logged with every water level reading.
- Suspended sediment is dependent on [density](#) and [water temperature](#) readings. If either of those fails, so will the suspended sediment reading.
- A correctly set *Orifice Separation* is critical for getting accurate suspended sediment readings. Please see the [section on Density](#) for details.
- The only way to disable suspended sediment computations and logging is to disable the *Water Temp Enable* setting. Please note that only -3 dual orifice Bubblers are capable of measuring suspended sediment.

Calibrating Suspended Sediment

If you know the current suspended sediment, you may calibrate the Bubbler's *Orifice Separation* setting. To do so, press SET while viewing the live reading of Suspended Sediment on the command line. Alternatively, type SUSPENDED SEDIMENT = 1000 on the command line to set it to 1000mg/L.

Logging

A secure flash chip in the Bubbler provides a logging capacity of more than 300,000 entries. Data will *not* be lost if power is removed. Once the log is full, the oldest data will be overwritten.

Each log entry consists of

- date and time (with a second resolution)
- name (e.g. Water Level)
- measurement reading (optional)
- measurement quality and units (optional)

Here are several examples of log entries:

- Water Level,10/11/2006,10:00:00,3.08,feet,
- Setup Change,10/10/2006,16:22:33,
- Reset Powerup,11/09/2006,15:52:17,1,

Minimally, Bubbler will log water level and various events. The user can decide how often to log water level (via [automeasure settings](#) see page 24).

There is not a means of erasing data from the log.

Events

Occasionally, the Bubbler will log events. Events are used to help troubleshoot the data.

The following actions will cause the Bubbler to log an event:

- Setup change (whenever any setting is changed)
- Log download (whenever the log is downloaded)
- Display On and Display off (whenever the user wakes the unit up by pressing a button)
- Command line enter (whenever the user connects via the RS232 port)
- Reset (log contains reset type and count)
- Errors (such as low battery and sensor failure)
- Before cal and after cal (logged whenever the user sets the water level to record the water level before and after the calibration)
- Log in events (if [password](#) is enabled), including failure to log in.

Downloading the Log

To logged data may be accessed via the front panel, via the RS-232 interface, and via an [SD card](#). SDI-12 does not provide access to the log

The log can be examined via the front panel (the [Logged Data](#) menu), or downloaded via command line (using the [LOG](#) command).

When downloading the log, the whole log or only parts of it can be downloaded. In addition, the Bubbler remembers the last log download and will allow downloads 'since last download', which means that the only parts of the log downloaded are those that have not been previously downloaded.

Logged Measurement Time

Measurements are not instant. Once initiated, a Bubbler measurement will take the user defined [averaging time](#) plus some overhead to complete. For example, a measurement that starts at 12:00:00, with an averaging time of 10 seconds will complete at about 12:00:11. That measurement will be logged with 12:00:00 as the timestamp. **The timestamp of the logged measurement is the time the measurement was started.**

Log Daily Values

The Bubbler can log diagnostic information at 23:59:59 each day. That information consists of [battery voltage](#), battery under load, [tank pressure](#), [pump run time](#), and Accubar [autozero](#)

Control of the log daily values setting: ([Station Setup > Other Setup > Log Daily Values](#), [LOG DAILY VALUES](#) command).

Log Accubar Pressure

With each water level measurement, the Bubbler can log diagnostic information. Water level and density readings are based upon pressure measurements made by Accubar sensors. Enabling this setting causes those pressures to be logged. Note that autozero is *not* applied to this logged value.

Single Bubbler units will log one pressure reading (*Press Line 1*) with each water level reading. This reading represents the pressure in orifice line 1.

Dual Orifice Bubblers will log two more pressure readings: *Press Line 2* which is the pressure in orifice line 2 and *Press Diff* which is the pressure difference between the two lines.

Prior to software version 1.65, those log entries were named *Accubar Pressure 1*, *Accubar Pressure 2*, and *Density Press*.

Control of the log Accubar pressure setting: ([Station Setup > Other Setup > Log Accubar Pressure](#), LOG ACCUBAR PRESSURE command).

SD Card Interface

The Bubbler supports SD card usage for downloading logged data and setup changes. An SD card is a portable media storage that is widely available on the commercial market. MMC cards may also be used with the Bubbler.

SD Cards must be formatted for FAT32. FAT, FAT8, FAT16 are not supported and may not be recognized by the Bubbler. The Bubbler can format the SD card, but it lacks a quick format feature; it takes many minutes for it to complete the format.

SD Card capacity goes up to 2GB. A 2GB card will provide ~50 million log reading capacity.

Only SD Cards are supported. SDHC, SDXC, SDUC are not supported.

SD Card Log Download

To download the log using an SD card, simply plug the card in.

- If the front panel is off when the card is plugged in, an automatic log download will start in 10 seconds. The automatic download will download since last download.
- If the display is on when the card is plugged in, the download log menu will appear. Navigate the menus and choose the appropriate [log download type](#).

There is a red LED that will light up while the SD card is in use. Please do not remove the card when it is in use.

Automatic Log Backup

If an SD card is left plugged in, the unit will perform an automatic backup of the log to the SD card. All the user needs to do is leave the SD card plugged in, and the Bubbler will periodically download the log and save it to a file on the SD card.

With an SD card left plugged in, four hours after the user stops using the display, and every four hours afterwards, the unit will download the logged data and append it to a file. Once the file exceeds about 2MB, a new file will be started. The backup will work until the SD card gets full, at which point it stops downloading.

When visiting the station for maintenance to retrieve the log, it is only necessary to remove the card that was left plugged in.

Setup and SD Cards

It is possible to save the current setup to an SD card. [SD Card Operations > Write Bubbler Setup to Card](#).

A setup saved to the SD card can be transferred to a PC using an SD card reader. A setup file can be edited using a text editor on a PC (such as Notepad). Once settings are changed, the file can be saved to the SD card and sent to the Bubbler, changing the Bubbler's setup.

Setup files on an SD card can be sent to the Bubbler using the [SD Card Operations > Read Bubbler Setup From Card](#) menu.

Setup

The Bubbler's setup is stored in secure memory, meaning it will not be lost if power is removed (for any time period). The setup of the Bubbler is broken into sections: Bubbler Setup, Accubar Setup, and Other Setup. All setup can be changed through any interface: [SDI-12](#), [front panel](#) or [RS232 command line](#).

Setting the setup to defaults will reset all the settings to factory defaults. Access is provided via [Station Setup > Other Setup > Default Setup](#), SDI-12 [XFD](#), and SETUP DEFAULTS command.

The whole setup may be saved to file using the [command line interface](#) or using an [SD card](#). A setup file can be edited using a text editor on a PC (such as Notepad). Once settings are changed, the file can be sent to the Bubbler via the [command line interface](#) or via an [SD card](#).

Connecting Bubbler to a Logger

The Bubbler will measure on its own schedule regardless of whether it is connected to another logger. This ensures redundancy of logged data. If the connected logger malfunctions, the Bubbler will keep collecting data.

The digital SDI-12 interface allows for a standardized connection to a logger. Please note that SDI-12 cannot provide power to the Bubbler – make sure to use the [proper power connection](#) (page 10). For full details on SDI-12, please refer to [the section](#) on page **Error! Bookmark not defined.**

The Bubbler can be attached to a telemetry device, such as a [modem](#), via its [RS232 port](#). Bubbler allows full access to status, setup and data via the RS232 port, using the command line interface detailed on page 53). Loggers that do not support SDI-12 should interface via the RS232 port.

To ensure that the logs of the Bubbler and the attached logger match (as far as water level goes), make sure that the [automeasure time and interval](#) of the Bubbler are the same as the measurement time and interval of the logger.

Ensure that the time of the Bubbler and logger match by [changing the time](#) of either one (page 33).

Satlink and Bubbler

When connecting a Bubbler to a Satlink, use the SDI-12 connection. Setup Satlink for an SDI-12 measurement (please see the Satlink manual for details). Make sure that Satlink measurement time and interval match the Bubbler's [automeasure time and interval](#).

Satlink will automatically synchronize the Bubbler's clock via SDI-12. This will happen as soon as Satlink is started; Satlink will then periodically ensure that Bubbler and Satlink clocks are in sync.

Connecting an External Sensor

A different pressure sensor may be used in conjunction with the Bubbler. In this scenario, the Bubbler provides the pressure required to keep the bubbles flowing down the orifice line, and the external sensor measures the pressure in the orifice.

Prior to software version 1.30, a setting called *external sensor* needed to be enabled when connecting an external sensors. Versions 1.30 and newer require no changes to settings when connecting an external sensor.

Bubbler Time

Bubbler time can be viewed and set via the front panel [top level menu](#), via the SDI-12 [XDT command](#), or by using the [TIME](#) command line.

Bubbler sports an RTC (real time clock) backed by an internal battery. The RTC keep ticking even if the main battery to the Bubbler is removed. The RTC will, at worst case, drift ± 2 minutes per month (0 to +50C). The lifetime of the RTC battery is about 5 years.

Battery Voltage

Bubbler must be powered via the “BAT” power connector (see page 10 for [connection details](#)).

When reporting battery voltage, Bubbler will report the two voltages: battery voltage when the pump is off, and battery voltage when the pump is on (also called battery voltage under load). Battery voltage can be read from the [front panel](#), SDI-12 [M1](#), or [BATT](#) command.

The Bubbler can log the battery voltage once a day – please see the section about [logging daily values](#) on page 30.

With versions 1.74 and newer, the Bubbler can log battery voltage and battery voltage under load with every stage reading. The setting **Log Battery** controls this behavior. Options are

- Disabled (Default)
 - System does not log battery voltage with every stage reading
- Normal
 - System measures and logs battery voltage with every stage reading
- Batt Under Load
 - System logs the most recently measured battery under load with every stage reading
- Both
 - System logs both battery voltage readings described above

Cut-off Voltage

Before the Bubbler turns on the pump, it will check the battery voltage. If that battery voltage is less than 10.0V, the operation will be aborted, (and an error recorded). Likewise, while the pump is running, if the battery voltage drops below 8.0V, the operation will be aborted.

Every time an Accubar measurement is made, the battery voltage is checked. If the voltage is less than 10.0V, the measurement will proceed, but the result will be marked with a battery low flag.

The red LED will come on whenever the battery voltage is less than required, indicating that the battery should be changed.

Password

You can enable password protection by configuring a password. If password protection is enabled, the user is allowed view setup and data. However, no changes to setup will be allowed until a password is entered. A password prompt will automatically appear whenever a setup change is attempted.

Via front panel, go to [Station Setup->Other Setup->Password](#). Press set and enter a password. Press set again and the password will be enabled.

Using the command line, type "PASSWORD = XXX" to set password to XXX. Type "PASSWORD =" to disable password usage.

To disable the password, enter a blank password.

Logging out is accomplished by turning off the display, by typing EXIT in the command line, or by powering down the unit.

SDI-12 is unaffected by password protection.

If you forget the password and want to clear it, reset the unit and press and hold the DOWN key. You must keep the key pressed until you see the message "Password Cleared" appear on the front panel.

Passive Sensor Mode

Passive sensor mode is a diagnostic mode in which the Bubbler does not turn on the pump. In this mode, the Bubbler will not maintain pressure. The Accubar sensor continues to measure pressure, but the Bubbler stops providing air flow through the orifice. The restrictor valve is bypassed, which means that the pressure inside the tank will become equalize to the pressure on the orifice line.

In passive sensor mode:

1. Pump is not turned on
2. Restrictor valve is bypassed

When in passive sensor mode, the red error LED will flash. The front panel and command line status will indicate that 'Bubbler is stopped'.

This mode can be accessed via the front panel via the [Diagnostics->PassiveSensor](#) menu, the SDI-12 [XPSM](#) command, and the command line [PASSIVESENSOR](#) command.

Flow Calculations

The Bubbler can calculate the flow of air out of its tank as a diagnostic. Note that this is just a diagnostic and the unit does not use this calculated value in its control loop. To view the flow, issue the DIAG command or use the Diagnostics menus. The flow will be labeled Flow 1 (and Flow 2 if there are two orifices). The units for the flow are SCCM.

Pump Watchdog

In normal operation, the system will operate the pump every few minutes to maintain pressure in the tank(s). The user can have the system automatically reset itself if the pump has not been operated in a specified amount of time. The Pump Watchdog setting specifies this time. With Pump Watchdog set to 00:30:00, the system will automatically reset the system if the pump has not operated for 30 minutes.

This is just an extra security feature built into the system to help the system automatically recover from unforeseen situations.

With PumpWatchdog set to 00:00:00, the pump watchdog test is disabled.

Warning, if you set pump watchdog too low, you could cause the system to reset in a normal situation. Consider the situation where the stream level is slowly going down. As the stream level decreases, the pump doesn't need to run because there is excess air already in the tank.

Note, while the unit is resetting, the system will not respond to SDI-12 commands. The system may Autozero the restrictor after reset if the bubble rate is less than 8 SCCM. If Autopurge is enabled, the system will purge 2 minutes after reset.

FastTrack

The FastTrack feature allows the Bubbler to operate at locations where the level rises or drops rapidly.

When water level drops rapidly the bubbler has excess pressure in the tank that must be released in order to keep the flow in the tube from getting too large, introducing an error.

When water level rises too quickly, the bubbler has inadequate flow to keep the water from coming in the orifice.

The solution to both issues is the FastTrack feature. With FastTrack enabled, the system will continuously monitor for these conditions and operate the valves to either increase the flow (rising levels) or remove excess pressure (falling levels).

For FastTrack to work, it must know the *Tube ID* and *Tube Length* of the orifice tubing. You will find these settings along with *FastTrack Enable* in the [Station Setup->Bubbler Setup menu](#).

When levels are falling, FastTrack kicks in when the pressure in the tank is 1.5 times the desired value. (This can be adjusted using the FTDownK hidden setting). When levels are rising, FastTrack kicks in when the flow in the tube is positive and 0.5 of its desired value (This can be adjusted using the FTUPK hidden setting).

The system will operate the bypass valve for 1 second (again a user setting FTDOWNTIME and FTUPTIME) and then delay for 2 seconds for the system to stabilize before allowing readings again (RestHold).

If *Log Diagnostics* is enabled and FastTrack operates, you'll see messages in the log concerning FastTrack Down and FastTrack Up events. Use the front panel [Diagnostics](#) interface or type [DIAG](#) on the command line to get diagnostics details about FastTrack. The Bubbler calls the pressure drop in the tube *deltaP*.

Please consult the factory before making changes to any of the FastTrack settings.

Front Panel Interface

The Bubbler features a two line LCD interface, six buttons and two LEDs. The front panel interface can be used to setup the station, examine it's status, view the current measurements, and view logged data.

Navigating the Menus

The menu has a tree structure, like directories in an operating system.

1. The [Bubbler menu tree](#) (page 38) can be navigated with the arrow keys. Press ▲ (UP) and ▼ (DOWN) to browse the menu items that are on the same level. On certain menus, press ► (RIGHT) to enter a sub menu, and ◀ (LEFT) to go up to the parent menu.
2. Some menu items offer a means to change setup. To change a value press SET. The prompt will change and a flashing cursor will appear. You can then use the arrow keys to select a different value.
 - a. When editing numbers with decimal points, the Bubbler can show the number in either scientific or decimal notation. To switch between the two notations, put the cursor on the E and press UP or DOWN.
 - b. Example value in decimal notation: *+00001.23 E*
 - c. Same value in scientific notation: *+1.230000E+00 E*
3. Once you have the desired value on the display, press SET again to make the change permanent or to cancel a change, press the OFF/CANCEL button.
4. In the case where there are only two possible values for a setting, pressing SET will flip-flop between the values and the change is made immediately.

Front panel key functions

- a. RIGHT will navigate to a sub-menu (assuming there is one).
- b. LEFT will go back to the parent menu.
- c. UP and DOWN will navigate among the menus on the same level.
- d. SET starts a change or confirms an action.
- e. CANCEL cancels a change or action. The CANCEL key is also labeled OFF.
- f. CANCEL also goes back levels.
- g. Hold CANCEL to go to the top of the menu.
- h. Hold UP or DOWN to change contrast setting.

Turning Display On/Off

The Bubbler will continue to measure and log data as long as a good battery is connected. The display turns off automatically after 5 minutes of inactivity in order to conserve power. The display can be turned on at any time by pressing any key.

To turn off the display, press the OFF/CANCEL button. You may need to press it several times to exit out of some menus first. Holding the OFF/ CANCEL button in any menu will turn off the display.

Contrast

If it becomes difficult to read the display, you may need to adjust the contrast. To set the contrast, press and hold the UP or DOWN arrow buttons until you see the CONTRAST prompt and keep holding the button until the display is readable. If the display becomes too dark or too light, press the opposite arrow key to reverse the contrast. Once the display is readable, release the arrow, and this setting will be stored for the next time the display is turned on.

Viewing Current Data

When the display is turned on, the last measured water level will display. The Bubbler will then initiate a new measurement and display the results as soon as the measurement completes (which is based on [averaging time](#)). As long as the water level menu is displayed, live readings will be continuously made

Understanding the “?” indicator.

If the Bubbler display a “?” after a value if there is a question about the [quality of the data](#).

If there are errors, the message ‘Hardware Error’ will be displayed when the front panel is turned on. In that case, you may press RIGHT for details. You may then press SET to clear the errors.

Front Panel Menu Tree

- Errors (only show if errors are present)
 - Hardware error details
 - [Stage](#) (live) and time of reading -- Press SET to calibrate
 - [Stage 2/Density/Inactive Line](#) Press SET to calibrate (Dual Orifice)*
 - [Tank Pressure](#) (live)
 - [Water Temperature](#)*
 - [Suspended Sediment](#)*
 - [Battery Voltage](#) (live)
 - [GPS](#)* (when Garmin GPS is enabled)
 - GPS Status
 - GPS Time of Last Sync
 - Local Time Offset
- [Logged Data](#)
 - Logged Water Level
 - Logged Events
 - All Logged Data
- Station Setup
 - [Bubbler Setup](#)
 - [Bubble Rate](#)
 - [Bubble 2 Rate](#) (Dual Orifice)*
 - [Bubble Units](#)
 - [AutoPurge Enable](#)
 - [AutoPurge Interval](#)
 - [Purge Pressure](#)
 - [Purge Length](#)
 - [Blockage Detection](#)
 - [Blocked Flow](#)
 - [Blocked Pressure](#)
 - [FastTrack](#)
 - [Tube ID](#)
 - [Tube Length](#)
 - Accubar Setup
 - [Automeasure Interval](#)
 - [Automeasure Time](#)
 - [Operating Mode \(Normal | Continuous\)](#)
 - [Averaging Time](#)
 - [Level Units](#)
 - [Level Right Digits](#)
 - [Log Temp in Box](#)
 - [Temperature Units](#)
 - [User Slope \(user units only\)*](#)
 - [User Offset \(user units only\)*](#)
 - [Field Calibration Offset](#)
 - [Field Calibration Offset 2](#) (Dual Orifice only)*
 - [Measurement Name](#)
 - [Water Temperature Setup](#) (Only if hardware is present)*
 - Water Temp Enable
 - Water Temp Type
 - C0 (Platinum Custom only)*
 - C1 (Platinum Custom only)*
 - C2 (Platinum Custom only)*
 - R0 (Platinum only)*
 - Stein A (NTC Thermistor only)*
 - Stein B (NTC Thermistor only)*
 - Stein C (NTC Thermistor only)*

Dual Orifice Setup (Dual Orifice only)*
[Dual Orifice Config](#)
[Orifice Separation](#) (Dual Density Mode only)*
[Separation Units](#) (Dual Density Mode only)*

Advanced Setup (consult factory before changing any of these settings)
Dual Orifice Manifld
[Log Diagnostics](#)
[Pump Watchdog](#)
Onboard Vref
Restrictor Slope
Restrictor Offset
Press Deadband
Pump Rate
Autozero Delay
Autozero Holdoff
Control Interval
Tank bleed delta
Max Line Press
Autozero samples
Accubar VREF warmup
Line switch holdoff
Tank switch holdoff
FlowK
Vol Tank
[FTDownK](#)
[FTUpK](#)
[FTDownTime](#)
[FTUPTIME](#)
[RestHold](#)

[Modbus Settings](#)
Modbus Enable
Modbus Device ID
Modbus Protocol
Modbus Parity
Delay before Tx
Delay after Tx
Modbus BaudRate

Other Setup
Station Name
[Garmin GPS](#)
Password
[Default Setup](#)
[Auto Output](#)
[Baud Rate \(for RS232\)](#)
[RS232 Wakeup](#)
[Hardware Flow Control](#)
[SDI-12 Address](#)
[SDI Data Old](#)
[Log Daily Values](#)
[Log Accubar Pressure](#)
[Log Battery](#)
[Log DQAP Samples](#)

[SD Card Operations](#)
[Download Log](#)
[Read Setup From SD Card](#)
[Write Setup to SD Card](#)

Format SD Card

Diagnostics

[Purge](#)

[Last Purge Results](#)

[Leak Test](#)

[Last Leak Test Results](#)

[Accubar 2 Configuration](#) (Dual Orifice only)*

[Accubar Pressure Diagnostic](#) (PSI, no [field cal offset](#), no [autozero](#))

[Tank and Restrictor Pressure](#)

[Pump Run Time](#)

[Accubar ID](#)

[Passive Sensor Mode](#)

[Flow Tube](#) (Fast Track)*

[deltaP](#) (Fast Track Pressure Drop in Tube)*

[Water Temp Diagnostics](#) (Water Temp only)*

[Density Temp](#) (Water Temp only)*

[Suspended Sediment](#)*

Software Version

Station Name and Time

SDI-12 Sensor Operation

The CF Bubble Gauge can function as an SDI-12 Sensor. This allows the CF Bubbler to connect to another data logger or transmitter to provide the data when requested. If you are not using the Bubbler with another data recorder or transmitter, you can skip this section.

For details on [SDI-12 wiring](#), please refer to page 10.

The most common SDI-12 command used with the Bubbler is the “M” measure command followed by the “D0” command. The “M” command requests the Bubbler to make a measurement and the “D0” command gets the data. While there are a lot of other commands available, most users will simply use the M, D0 commands.

The remainder of this section documents all the SDI-12 commands supported by the Bubbler. Note that most any setting that can be changed from the front panel, can also be changed via SDI-12.

SDI-12 Reference

The Bubbler will respond to all standard SDI-12 commands. To use the SDI-12 commands you must have a data logger or interface that supports the SDI-12 standard. More details on the SDI-12 interface can be found at <http://www.sdi-12.org>.

The Bubbler is compliant with SDI-12 Specifications version 1.3, with the exception of being able to abort measurements. If a measurement command is issued to the Bubbler, the Bubbler will proceed to measure. If the measurement is aborted (by issuing an SDI-12 break), the Bubbler will not issue a service request after it completes the measurement. However, the Bubbler will not abort the measurement. After the measurement abort is issued, other commands may be issued to the Bubbler, and the Bubbler will respond to them properly.

The general form of an SDI-12 command is:

aC!<CR><LF>

where a is the sensor address 0-9,A-Z,a-z,*, ?. (Addresses * and ? will address any sensor, regardless of its address.)

C is the command and ! is the last character of the command.

Note on validity: Some SDI-12 water level readings will return a validity flag.

The **validity** can be

- 0 - valid
- 1 - sensor failure
- 2 - reading old (returned data is from a previous reading or -999.99, see below)
- 3 - reading not available (Dual Orifice Bubbler – see below)

Why would the reading be old? The Bubbler may have been doing a purge which prevents the Accubar sensor from measuring.

When a reading is old, the unit can return either a previous reading or -999.99, depending on how it is setup (SDI Data Old setting in [Station Setup > Other Setup](#)).

The Dual Orifice Bubbler is capable of making two readings in some [configurations](#) (*dual separate, dual density*). If it is *not* configured for two readings, it will return 3 as the validity of the second reading.

The standard SDI-12 commands for the **standard CF Bubbler** are below. The reference for Dual Orifice Bubbler is in a separate table following this one.

	Name	Command(s)	Response	Example/Notes
	Acknowledge Active	a!	A	
I	Send Identification	a!	a13 SUTRON CFBBLR1.ssssss 1.33 1 indicates a Single Orifice Bubbler ssssss is the Accubar ® serial number 1.33 is the software revision	
A	Change Address	aAb!	B	Changes address to b
?	Address Query	?!	A	
M MC C CC	Measure Accubar water level	aM! aD0!	Attn a + level (pg 18) + units (see XUP pg 48) +level validity (pg 41)	Returns the water level in user specified units.
	<i>Measure Accubar water level in DQAP mode</i>		<i>The M results above, plus the following:</i> +DQAP StdDev +DQAP Keepers +DQAP Outliers (pg 25)	<i>If DQAP Mode is enabled, M contains additional DQAP results.</i>
M1 MC1 C1 CC1	Measure water level in PSI (does not apply field calibration offset) and battery voltage	aM1! aD0!	Attn a + level (pg 18) in PSI + temperature (pg 23) in Celsius + battery voltage (pg 33) + battery under load (pg 33) +level validity (pg 41)	Diagnostic command used to see the unmodified Accubar reading, Accubar temperature, current battery voltage, and battery voltage under load (during pump on)
M3 MC3 C3 CC3	Get last automeasured Accubar water level.	aM3! aD0!	Attn a + level (pg 18) + units (see XUP pg 48) +age +level validity (pg 41)	Retrieves the last measured water level during an automeasure. Age is the number of seconds since the reading was made.
	<i>Get last automeasured Accubar water level in DQAP mode</i>		<i>The M3 results above, plus the following:</i> +DQAP StdDev +DQAP Keepers +DQAP Outliers (pg 25)	<i>If DQAP Mode is enabled, M3 contains additional DQAP results.</i>
M4 MC4 C4	Measure Water Temperature	aM4! aD0!	Attn A + level (pg 18)	Measures water level and water temperature and returns the results.

	Name	Command(s)	Response	Example/Notes
CC4			+ water temp (pg 25) + density from water temp (pg 25) +level validity (pg 41)	
M5 MC5 C5 CC5	Get last automeasured Water Temperature	aM5! aD0!	Attn A + level (pg 18) + water temp (pg 25) + density from water temp (pg 25) +level validity (pg 41)	Returns the last automeasured water level and temperature.
M6 MC6 C6 CC6	Measure Accubar water level and temperature	aM6! aD0!	Attn a + temperature (pg 23) + temperature units (pg 49) + level (pg 18) +level units (see XUP pg 48) +level validity (pg 41)	The temperature and water level are provided in user chosen units.
M7 MC7 C7 CC7	DQAP 15 and 16 second Averages	aM7! aD0!	Attn a +15 sec average +60 sec average (pg 27)	DQAP Mode only. Please see DQAP Section .
M8 MC8 C8 CC8	Measure Bubbler internal sensors	aM8! aD0!	Attn a + restrictor pressure (pg 14) + tank pressure (pg 14) + temperature (pg 14) + validity (pg 41)	The provided readings are of the Bubbler's internal sensors. Measurements are in units of PSI and C.
M9 MC9 C9 CC9 R9	Purge Now	aM9! 0D0!	Attn a +duration +pumptime +success (if not zero, see hardware error table , pg 69)	This command requests a purge be done now. The response to the M command will tell how long the purge will last. The data provided is the result of the last purge: duration is how long the purge took in seconds, pump time is how long the pump was on during the purge in seconds, and success is zero if the purge completed successfully. For a Dual Orifice Bubbler, the time reported will be combined from purging both lines.
V	Verification	aV!	A +error count +total reset count + Accubar autozero +restrictor autozero	Diagnostic results tell the total number of errors (0 if there are no errors), the total number of resets, the results of the Accubar autozero, and the restrictor autozero.

The standard SDI-12 commands for the **Dual Orifice Bubbler** are defined below. The standard CF Bubbler's commands are defined in a different table (see above).

The major differences between the Dual and Single Orifice Bubblers are the number of sensor readings made by the system. The Dual Orifice Bubbler will provide two water level readings, where the Single Bubbler will provide only one. Additionally, the Dual Orifice Bubbler produces one additional tank pressure and one additional restrictor pressure reading.

	Name	Command(s)	Response	Example/Notes
	Acknowledge Active	a!	A	
I	Send Identification	a!	a13 SUTRON CFBBLR2.ssssss 1.33 2 indicates a Dual Orifice Bubbler ssssss is the Accubar ® serial number 1.33 is the software revision	The serial number reported is that of the first Accubar sensor. If the unit is equipped with two Accubar sensors, the serial number of the second sensor can be accessed via the XAI2 command.
A	Change Address	aAb!	B	Changes address to b
?	Address Query	?!	A	
M MC C aCC	Make Accubar sensor readings	aM! aD0!	Attn a + level (pg 18) + units (see XUP pg 48) +level validity (pg 41) + level 2 or density (pg 19) +level 2 validity	This setting will return either two water level readings or one water level and one water density reading, along with quality values for each. If the unit is not setup to produce a second reading, level 2 will come back as -999. This is the case for Dual Expanded and Single modes.
M1 MC1 C1 CC1	Make Accubar sensor readings in PSI (does not apply field calibration offset or density or autozero) and battery voltage	aM1! aD0!	Attn a + level (pg 18) in PSI + temperature (pg 23) in Celsius + battery voltage (pg 33) + battery under load (pg 33) +level validity (pg 41) + level 2 or density +temperature 2 +level 2 validity	Diagnostic command used to see the unmodified Accubar reading, Accubar temperature, current battery voltage, and battery voltage under load (during pump on). Note that if the unit is setup for a density measurement, the level 2 reading will be the pressure difference between the two lines. If the unit is not setup to produce a

	Name	Command(s)	Response	Example/Notes
				second reading, level and temperature 2 will come back as -999.
M2 MC2 C2 CC2	Measures and reports water level both in user units (with the field calibration offset applied) and in kPa (without the offset and without autozero)	aM2! aD0!	Attnn a +level in user units +level in kPa (no field cal offset, no autozero) +level validity +level 2 in user units +level 2 in kPa (no field cal offset, no autozero) +level 2 validity	Diagnostics command provides both the pressures and the water level in the lines. If the unit is not setup to produce a second reading, level 2 will come back as -999
M3 MC3 C3 CC3	Get last automeasured Accubar water level.	aM3! aD0!	Attnn a + level (pg 18) + units (see XUP pg 48) +age +level validity (pg 41) + level 2 or density (pg 19) +level 2 validity	Retrieves the last measured water levels during an automeasure. Age is the number of seconds since the reading was made.
M4 MC4 C4 CC4	Measure Water Temperature	aM4! aD0! aD1!	Attnn A + level (pg 18) + water temp (pg 25) + density from water temp (pg 25) + level 2 or density (pg 19) + suspended sediment (pg 29) +level validity (pg 41)	Measures water level and water temperature and returns the results. aD1! Shows density, suspended sediment, and validity
M5 MC5 C5 CC5	Get last automeasured Water Temperature	aM5! aD0! aD1!	Attnn A + level (pg 18) + water temp (pg 25) + density from water temp (pg 25) + level 2 or density (pg 19) + suspended sediment (pg 29) +level validity (pg 41)	Returns the last automeasured water level and temperature.
M6 MC6 C6 CC6	Measure Accubar water level and temperature	aM6! aD0!	Attnn a + temperature (pg 23) + temperature units (pg 49) + level (pg 18) +level units (see XUP pg 48) +level validity (pg 41) + level 2 or density (pg 19) +level 2 validity	The temperature and water level are provided in user chosen units.
M8 MC8 C8 CC8	Measure Bubbler internal sensors	aM8! aD0!	Attnn a + restrictor pressure (pg 14) + tank pressure (pg 14) + temperature (pg 14) + validity (pg 41) + restrictor 2 pressure (pg 14) + tank 2 pressure (pg 14)	The provided readings are of the Bubbler's internal sensors. Measurements are in units of PSI and C.
M9 MC9 C9	Purge Now	aM9! 0D0!	Attnn a +duration	This command requests a purge be done now. The

	Name	Command(s)	Response	Example/Notes
CC9 R9			+pumptime +success (if not zero, see hardware error table , pg 69)	response to the M command will tell how long the purge will last. The data provided is the result of the last purge: duration is how long the purge took in seconds, pump time is how long the pump was on during the purge in seconds, and success is zero if the purge completed successfully. For a Dual Orifice Bubbler, a purge in each line will be initiated. The time reported will be combined from <u>purging both lines</u> .
V	Verification	aV!	A +error count +total reset count + Accubar autozero +restrictor autozero +Accubar Two autozero +restrictor two autozero	Diagnostic results tell the total number of errors (0 if there are no errors), the total number of resets, the results of the Accubar autozero, and the restrictor autozero. Only Dual Orifice Bubblers will return Accubar Two and restrictor two autozero results.

The table below shows the extended SDI-12 commands for the Bubbler.

	Name	Command(s)	Response	Example/Notes
X?	Request unknown address	*X?!	<u>A</u> Address of the sensor	This command causes the Bubble to identify itself.
XAD	Set SDI-12 address	aXADnAn! n the new SDI-12 address, repeated twice	a0011 no response if the addresses do not match	Note: a D0 command issued after will return the new address.
XAI and XAI2	View extended Accubar identification	aXAI! or aXAI2!	aIccccccmmmmmvvxxxxx II SDI version (1.3) cccccc is " SUTRON " mmmmm sensor model vvv hardware version xxxxx Accubar Sensor ID	
XE	View/Set field calibration offset (pg 22)	aXEkdu! k is useful only for the Dual Orifice Bubbler. It can be either 1 indicating water level in line 1 or 2 indicating water level in line 2 or density. For Dual Expanded mode, omit k to set the water level in the currently active line. Do <i>not</i> place a + before k. d is the new field calibration in the units (see XUP pg 48) indicated by u. If the Dual Orifice Bubbler is setup to measure density, d is the new Orifice Separation and u are the <i>Separation Units</i> (NOT field calibration units): 0 feet 1 inches 2 cm 3 m 4 mm k, d, and u may be omitted. If k is omitted, line 1 is referenced. If d is omitted, the field cal offset will be unaffected (but can be read by following up with an D0 command). If u is omitted, d is assumed to be in PSI.	attt1 where ttt indicates the command will be complete in ttt seconds and 1 indicates one value can be collected.	0XE+0+0 (will set the field calibration offset to 0 – standard single orifice Bubbler) 0XE1+1.0+0 (will set the field calibration offset for line one to 1.0 feet – Dual Separate or Dual Expanded configuration) 0XE2+5+3 (will set the field calibration 2 offset to 5cm – Dual Separate or Dual Expanded configuration) 0XE2+12+1 (will set the orifice separation to 12 inches - Dual Density configuration) Note: a D0 command issued after XE is complete will display the new offset in the current units (as set by the XUP command).
XS	Set water level (pg 22)	aXSku! k is useful only for the Dual Orifice Bubbler. It can be either 1 indicating water level in line 1 or 2 indicating water level in line 2 or density. Do <i>not</i>	attt1 where ttt indicates the command will be complete in ttt seconds and 1 indicates one value can be collected.	Example: 0XS+3 Set water level to 3. Uses currently selected units. 0XS2+7.87+0 Set water level in line

	Name	Command(s)	Response	Example/Notes
		<p>place a + before k.</p> <p>d is the desired water level and in the units (see XUP pg 48) indicated by u. The Bubbler will adjust the field calibration offset to ensure the reading matches the value entered.</p> <p>If the Dual Orifice Bubbler is setup to measure density, this command will change Density. Density is always in gm/ml: u is not relevant.</p> <p>k, d, and u may be omitted. If k is omitted, line 1 is referenced. If d is omitted, the field cal offset will be unaffected (but can be read by following up with an D0 command). If u is omitted, d is assumed to be in currently selected units.</p>		<p>2 to 7.87 feet</p> <p>Note: a D0 command issued after XS is complete will display the new offset in the current units (as set by the XUP command).</p>
XOM	Set/display operating mode (pg 24)	<p>aXOM+m! m is optional. Omit m to read the current mode, include it to change the mode. m = 0, normal mode, measure only when data is requested m = 1, continuous mode, measure continuously and provide data when requested.</p>	<p>attt1 where ttt indicates the command will be complete in ttt seconds and 1 indicates one value can be collected.</p>	<p>Example: 0XOM+0! (puts device into normal mode) Note: a D0 command issued after XS is complete will display the operating mode.</p>
XT	Set/display averaging time (pg 25)	<p>aXT+t! t is optional. Omit t to read the current value, include it to change. t = averaging time in seconds (0 to 900 seconds)</p>	<p>attt1 where ttt indicates the command will be complete in ttt seconds and 1 indicates one value can be collected.</p>	<p>Example: 0XT+10! (sets the averaging time to 10 seconds) Note: A D0 command issued after will return the averaging time.</p>
XUP	Set/display level units & level right digits (pg 23)	<p>aXUP+n+d! Both n and d are optional. Include them if you want to change the values.</p> <p>n = 0 feet n = 1 PSI n = 2 kPa n = 3 cm n = 4 m n = 5 mm n = 6 user units</p> <p>n = 9 user units (backwards compatability)</p> <p>d = number of places right</p>	<p>attt2 where ttt indicates the command will be complete in ttt seconds and 2 indicates two values can be collected.</p>	<p>Example: 0XUP+1+2! select PSI with 2 right digits</p> <p>Note: a D0 command issued after the XUP will return the value of the units that are selected and the number of digits right of the decimal point. If backwards compatability user units is used (+9), unit will report +6 for units.</p>

	Name	Command(s)	Response	Example/Notes
		of the decimal		
XUT	Set/display temperature units (pg 23)	<u>aXUTn!</u> n is an optional parameter. Include it only if you want to change the value. n = 0 for Celsius, n = 1 for Fahrenheit	<u>attt1</u> where ttt indicates the command will be complete in ttt seconds and 1 indicates one value can be collected.	Example: 0XUT1! (set temperature units to F) Note: a D0 command issued after the XUT will return the value of the units that are selected.
XUU	Set/display user units (pg 23)	<u>aXUUso!</u> Both s and o are optional. Include them if you want to change the values. where s is the pressure scale factor and o is the offset, User output = (PSI)*scale + offset	<u>attt2</u> where ttt indicates the command will be complete in ttt seconds and 2 indicates two values can be collected.	Example: 0XUU+27.63+0 (27.63 inches per PSI) Note: a D0 command issued after XUU will return the scale and offset. Note: Be sure that the units of pressure (XUP) are set to user units (9).
XFD	Set factory defaults (pg 31)	<u>aXFD!</u>	<u>a0011</u> indicating that the command will take 1 second and 1 value can be collected.	Note: a D0 command issued after the XFD command will return the operating mode.
XBF	Set/display bubble rate and units (pg 13)	<u>aXBF+r+u</u> Both r and u are optional. Include them only if you want to change the values. r is the bubble rate and u is the bubble units (u=0 bubbles/minute, u=1 SCCM)	<u>attt2</u> where ttt indicates the command will be complete in ttt seconds and 2 indicates two values can be collected.	0XBF+50+0 Note: a D0 command issued after command will return the bubble rate and units.
XOP	Set/display auto output (pg 55)	<u>aXOP+b!</u> b is optional. Include it to change the value. b = 0 disable output b = 1 enable output	<u>a0011</u> indicating that the command will take 1 second and 1 value can be collected.	Note: a D0 command issued after command will return the auto serial output.
XPSM	Set/display passive sensor mode (pg 34)	<u>aXPSM+b!</u> b is optional. Include it to change the value. b = 0 normal mode b = 1 passive sensor	<u>a+n</u> n = 0 normal mode n = 1 passive sensor	Passive sensor mode is a diagnostic mode – the Bubbler will not maintain pressure in that mode!
XDT	Set/display date and time (pg 33)	<u>aXDT!</u> this command reads the current time aXDTYYYY/MM/DD HH:MM:SS! a is address XDT is the command to set the date and time YYYY is the year MM is the month (01 to 12) DD is the day of the month (01 to 31)	aYYYY/MM/DD HH:MM:SS+q+g a is address YYYY is the year MM is the month (01 to 12) DD is the day of the month (01 to 31) HH is the hour (military time 0 to 23) MM is the minutes SS is the seconds q is a single digit that indicates the quality of the time. 0 means the time is invalid. 1 can mean that time was set since bootup (if no GPS is present), or that the time has been synced to the GPS in the last 12 hours	Example set date time command: 0XDT2005/09/01 13:15:00! Sets the date to the 1st of September2005, and the time to 1:15:00 PM.

	Name	Command(s)	Response	Example/Notes
		HH is the hour (military time 0 to 23) MM is the minutes SS is the seconds	(if a GPS is present). g is a single digit that indicates the presence of the GPS. 0 means no GPS is present, 1 means that a GPS is present.	
XAZ	Invoke autozero	aXAZ!	A	Tells the Bubbler to do an Accubar autozero. Use command V! to get results.
XRST	Reset unit	aXRST!	A	Tells the Bubbler to reset itself. Bubbler software will reboot after this command is issued.
XXS	Generic set/display setup command	See below for details	See below for details	See below for details

XXS Generic Change Bubbler Setup Command

This command is used to read and to make changes to all setup data in the unit.

To change the setup, it is used in the following manner:

XXS+s+n+v1+v2+v3+...+vx where

s is the setup identifier and must be equal to 1

n is the setup variable to read or to start making changes at.

v1 is the new value to write for the first variable

v2 is the value to write for the next variable

The setup variables are accessed using their order in the software meta variable map as seen in the following table. The values than can be used for any of the variables can be seen in the Bubbler Settings and Accubar Settings sections.

IMPORTANT! Please ensure that you have the correct version of the Bubbler software before using the commands below. The data below was updated with version 1.67.

- | | |
|--------------------------------|---------------------------|
| 1. Orifice Configuration | 29. Log Accubar Pressure |
| 2. Orifice Separation | 30. SDI Data Old |
| 3. Separation Units | 31. Measurement Name |
| 4. Bubble Units | 32. Tube ID |
| 5. Bubble Rate | 33. Tube Length |
| 6. Bubble 2 Rate | 34. FastTrack |
| 7. AutoPurge Enable | 35. SDI12 Address |
| 8. AutoPurge Interval | 36. Garmin GPS Enable |
| 9. Station Name | 37. GPS Local Time Offset |
| 10. Purge pressure | 38. Water Temp Enable |
| 11. Purge length | 39. Water Temp Type |
| 12. Blockage detection | 40. C0 |
| 13. Blocked flow | 41. C1 |
| 14. Blocked pressure | 42. C2 |
| 15. Automeasure Interval | 43. R0 |
| 16. Automeasure Time | 44. Stein A |
| 17. Operating Mode | 45. Stein B |
| 18. Averaging Time | 46. Stein C |
| 19. Level Right Digits | 47. Modbus Enable |
| 20. Level Units | 48. Modbus Device Id |
| 21. Log Temp in Box | 49. Modbus Protocol |
| 22. Temperature Units | 50. Modbus Parity |
| 23. User Slope | 51. Delay Before Tx |
| 24. User Offset | 52. Delay After Tx |
| 25. Auto Output | 53. Modbus Baud Rate |
| 26. Field Calibration Offset | 54. RS232 wakeup |
| 27. Field Calibration Offset 2 | 55. Hardware Flow Ctrl |
| 28. Log Daily Values | |

An example command to change the bubble units to BPM is:

XXS+1+4+0

You can also change bubble units to BPM and bubble rate to 22.5 together in the same command by typing:

XXS+1+4+0+22.5

To read a setup value, issue command XXS+1+n!, where n is the setup variable whose value you are interested in. For example, to read the current bubble rate, issue command XXS+1+5! and follow it up with a D0! command. The reply to D0 will have the bubble rate.

Any settings that allow for a negative value can be set using a '-' as a delimiter, such as changing the user offset.

XXS+1+24-5.5 would change the offset to -5.5

Changing the station name can use either a '+' or '-' delimiter and may contain spaces:

XXS+1+9+New Name+20 would change the station name to "New Name", and the Purge Pressure to 20.

RS232 Command Line Interface

The RS232 interface provides a simple way to connect the unit to PCs, modems and other communications devices. [Details on the DB9 connector](#) are on page 11.

Microsoft Windows usually comes with a program called HyperTerminal. It can be found by going to the Windows start menu, Programs, Accessories, Communications.

By default the RS232 interface operates at 115200 Baud, no parity, 8 data bits, 1 stop bit. Changing the baud rate can be done via the front panel: [Station Setup > Other Settings](#), or via the command line by typing "BAUD RATE".

If connecting to a PC, use a standard DB9 serial cable. If connecting to a modem or a logger, you are likely to need a null modem adapter.

To start command line mode, send carriage return or line feed (or both). If using HyperTerminal or a similar program, simply press ENTER. The unit will respond with a prompt >

RS232 Setup

The setting *RS232 Wakeup* controls what is required to wake the unit up via the RS232 connection. The options are:

- Wake on RTS (default)*
- Wake on DTR*
- Wake on either RTS or DTR*
- Always on*

If setup to wake on *RTS*, *DTR*, and *RTS or DTR*, the connected device must assert said line for communication to work. At least half a second needs to occur between the assertion of the correct control line and the start of communication (automatically done by HyperTerminal). The unit can also be setup to be always on, which increases power consumption but requires neither *RTS* nor *DTR* to establish RS232 communication. If setting up the unit with a modem, it is likely that *Wake on DTR* would be the correct option that results in lowest power consumption. However, it will depend on the modem. Access this setting via the front panel: [Station Setup > Other Settings](#), or via the command line.

Please note that the unit will always assert DSR (as long as it has power).

Hardware flow control via lines *RTS* and *CTS* (a.k.a. hardware handshaking) can be enabled via the *Hardware Flow Ctrl* setting. Enabling the setting can improve communication, especially if using a modem. When handshaking is on, the receiver is able to pause the data flow from the transmitter. Access this setting via the front panel: [Station Setup > Other Settings](#), or via the command line.

Please note that if *RS232 Wakeup* is set to wake on *RTS*, it is not possible to use *Hardware Flow Ctrl*.

Machine to Machine Communication

All commands may be preceded with an !. If they are, there is no echo, and a concise reply meant for machine to machine interaction is returned. Commands would be preceded by an ! if they were sent by an Xpert or some such computer.

Viewing Water Level

To initiate a new [water level measurement](#), type [MEAS](#). To see the [last automeasured](#) water level, including details, type [LAST](#). The output by the Bubbler will look like this:

```
Accubar Reading
Water Level 7.01 feet
```

Bringing the Benefits of Real-Time Data Collection to the World

Sutron Corporation, 22400 Davis Drive, Sterling, Virginia 20164

Internal Temp 23.38 C
Internal Sensors
Restrictor Pressure 31.259 PSI
Tank Pressure 31.263 PSI

For a concise version, try !LAST or !MEAS;

7.01, 23.38
31.259, 31.263,

Please note that if additional features are enabled, the output will have additional data:

- Dual orifice Bubblers may provide second stage and density readings.
- The water temperature sensor will provide a reading.
- DQAP will provide four additional readings.

The capture below is from a Bubbler with water temperature and DQAP enabled:

>MEAS
Accubar Reading
Stage 0.447 feet
Internal Temp 19.71 C
Water Temp 0.104 C
DQAP 0.447, StdDev 0.006, Keepers 156, Outliers 0
Internal sensors
Rest 1 Pressure 0.001 PSI
Tank 1 Pressure 25.211 PSI
Onboard Temp 20.85 C

>LAST
Last Accubar Reading
Stage 0.447 feet
Internal Temp 19.71 C
Water Temp 0.104 C
DQAP 0.447, StdDev 0.006, Keepers 156, Outliers 0

>!MEAS
>0.447, 19.72
0.100
0.447, 0.006, 180, 0
-0.004, 25.014, 20.79,

>!LAST
0.447, 19.72
0.100
0.447, 0.006, 180, 0

Downloading the Log

The Bubbler will save the water level in its flash memory each time a measurement is made. This data is then available to download to via the RS232 port. The command “LOG” command will start a Y-Modem transfer of the log to the connected device. For details on [logged data](#), please see page 25.

There are optional parameters that alter what data is downloaded:

- “LOG” with no parameters will download since last.
- “LOG ALL” gets whole log.
- “LOG X” gets X last days (“LOG 3” gets last 3 days worth of data)

“LOG timeStart” gets data since provided date
“LOG timeStart timeEnd” gets data between provided dates
time can be YYYY/MM/DD HH:MM:SS or YYYY/MM/DD or HH:MM:SS
e.g. "LOG 12:00:00 13:00:00"
e.g. "LOG 2006/01/20 12:00:00 2006/01/21 12:00:00"

Auto Output

When the Bubbler has *auto output* mode enabled (via front panel, [Station Setup>Other Settings>Auto Output](#), command line AUTO OUTPUT), it will automatically send data out on the RS232 port. The data will come out at whatever *baud rate* is setup (via front panel, [Station Setup>Other Settings>Baud Rate](#), command line BAUD RATE). If connected via HyperTerminal, and if command line mode is active, type EXIT to leave command line mode and to capture the auto output.

With the default setup, data auto output is the water level. It is output as fast as it is measured (which depends on user settings), once a second at most. The data is ASCII. This is an example of the output:

46.3
46.3
46.4
46.4

If additional features are enabled, the output will provide multiple comma separated values. The order of the data is as follows

- Water Level (always output first)
- Second Water Level
- Density
- Water Temperature
- DQAP
 - StdDev
 - Keepers
 - Outliers

Example autoutput of a system with Water Temperature and DQAP

0.014,21.380,0.000,10,0
0.014,21.380,0.000,10,0

RS232 Command Reference

Documentation Legend:

- + If any command **is followed by +**, it means that as long as the command starts with the indicated word, it will be accepted.
E.g. MEAS + means that typing “MEAS”, “MEASURE”, or “MEASXXX” will all have the same effect.
- 0 **If a 0 follows** a listed command, it means that the command can optionally be followed by the character 0.
E.g. “DIAG” will show the system diagnostic status. “DIAG 0” will first show current status and then clear the status.

! NOTE:

All commands may be preceded with an !. If they are, a concise reply meant for machine to machine interaction is returned. Commands would be preceded by an ! if they were sent by an Xpert or some such computer.

E.g. “MEAS” will show
Accubar reading
Pressure 6.41 feet
Internal Temp 23.91 C
“!MEAS” will show

6.41, 23.91

NOTE:

No **individual setup commands** are documented here. Every setup variable can be viewed by typing its name.

E.g. "BUBBLE RATE" will show the current rate.

Every setup variable can be changed by typing its name = new value.

E.g. "BUBBLE RATE = 15" will set the current rate to 15 (of whatever units are currently chosen).

List of commands

ACCUBAR +

Initiates, waits for, and shows the results of [Accubar readings](#).

AUTOZERO +

Shows the results of the last [autozero](#) (for both Accubar and restrictor). If AUTOZERO NOW is typed a new autozero is initiated.

AVG

DQAP mode only. Shows the [15 second and 60 second](#) averages.

BATT +

Shows the current [battery reading](#) and the last reading during pump on.

DENSITY = 1.0

[Sets the density](#) to 1.0gm/ml. User can choose any number between 0.9 and 1.1. Please see the section on density on page 19. Dual Orifice Bubbler only. Type DENSITY = PURE to indicate lines are in pure water.

DIAG + 0

Shows system diagnostics, including system resets, [autozero](#) results, [Accubar sensor ID](#), and pump run time. Dual Orifice Bubblers will also show the *Orifice Config* and the information about the second Accubar sensor (No Accubar Found, Stage, Density).

If followed by 0, it will clear system resets.

DOWNLOAD

See [LOG](#)

EXIT

Quits command line.

HI

System replies with "Hello"

INTERNAL

Initiates, waits for, and shows the results of [Bubbler internal sensor](#) measurements.

LAST +

Shows the [last automeasured](#) reading.

LEAK TEST

Shows the results of the last [leak test](#). If LEAK TEST NOW is typed, Bubbler starts a leak test, shows user the pressures as the leak test runs, and shows the leak test results once the test is complete.

A dual orifice Bubbler can test only one or both lines for a leak. LEAK TEST NOW 1 tests line 1, LEAK TEST NOW 2 tests line 2, and LEAK TEST NOW tests both lines.

LOG

This command is used to download the [log](#). It can be followed by optional parameters indicating what part of the log to download.

LOG with no parameters will download since last.

"LOG ALL" gets whole log.

"LOG X" gets X last days ("LOG 3" gets last 3 days worth of data)

"LOG timeStart" gets data since provided date

"LOG timeStart timeEnd" gets data between provided dates

time can be YYYY/MM/DD HH:MM:SS or YYYY/MM/DD or HH:MM:SS

e.g. "LOG 12:00:00 13:00:00"

e.g. "LOG 2006/01/20 12:00:00 2006/01/21 12:00:00"

LEVEL = 14.5

[Sets the water level](#) to 14.5 (of whatever units are currently chosen). User can choose any number, not just 14.5. Please see the section Setting Water Level on page 22.

Dual Bubbler units setup for Dual Separate mode can have the water level for the second line set by typing LEVEL 2 = 14.5

In [Dual Expanded](#) mode, if you type LEVEL = 14.5, the currently active line will be affected. To affect a specific line, type LEVEL 1 = 14.5 and LEVEL 2 = 14.5.

MEAS +

Initiates, waits for, and shows the results of sensor measurements. That includes [Accubar readings](#) as well as [Bubbler internal sensor](#).

PASSWORD

Used to prevent unauthorized access to station. Type "PASSWORD = XXX" to set password to XXX. Type "PASSWORD =" to disable password usage.

PASSIVESENSOR

If "PASSIVESENSOR ON" is typed, it places the Bubbler into [passive sensor mode](#). "PASSIVESENSOR OFF" will take the Bubbler back to normal mode. In passive sensor mode, the Bubbler will not turn on the pump (it will not maintain pressure), it will always keep the restrictor valve in the bypassed position, and it will NOT autozero the Accubar (0 is used as the autozero result). Bubbler's status will indicate that "Bubbler is stopped" when in passive sensor mode.

PUMP +

If typed without any parameters, the current state of the pump (on or off) is shown, along with the [pump run time](#) in days.

If "PUMP ON" is typed the pump will turn on and stay on for up to three minutes at which point the control will shut it off. No provisions exist for protecting the Accubar sensor from excessive pressure.

If "PUMP OFF" is typed, the pump will turn off.

If followed by a number (floating point expressed in seconds), the pump will turn on for that amount of time. E.g. "PUMP 2.5" will have the pump turn on, stay on for 2.5 seconds and then turn off.

PURGE

Type PURGE to see the results of the last [purge](#). Type PURGE NOW to have Bubbler initiate an immediate purge.

A dual orifice Bubbler can purge only one or both lines. PURGE NOW 1 for line 1, PURGE NOW 2 for line 2, and PURGE NOW for both lines.

REBOOT

Does a software resets of the system.

RESETS + 0

Shows system diagnostics, including system resets. If followed by 0, it will clear system diagnostic status.

RESTRICTOR +

Shows the reading of only the [internal restrictor sensor](#).

SETUP

If provided without any other parameters, it lists all setup details. That includes each setup variable and its current value.

Can be followed by a setup variable name and a new value for that variable.

E.g. "CHANGE STATION NAME = SUTRON"

If SETUP DEFAULT is issued, it will reset the entire setup to defaults.

STATUS 0

Shows system status including time, boot time, battery readings, last measurements, current internal sensor readings, and any hardware errors that may exist. For the Dual Orifice Bubbler in Dual Expanded Mode, the currently [active line](#) will be shown. If followed by 0, it clears the hardware errors.

SUSPENDED SEDIMENT = 1000

Measures [suspended sediment](#) and shows the result. Type SUSPENDED SEDIMENT = 1000 to calibrate.

TIME

Shows the current [system date and time](#). If followed by a new time, it changes the system time.

UPG +

Initiates a system software upgrade. It needs to be followed by the YModem transfer of an .upg file specific to the product. Both the main application and the bootloader are upgraded this way (but each needs its own .upg file). Check www.sutron.com for software upgrades.

VER +

Shows the current software version, including build date and time and the bootloader version.

WATER TEMP = 15

Measures [water temperature](#) and shows the result. Type WATER TEMP = 15 to set the water temperature.

List of setup variables

Type SETUP to get a list of the whole setup. Every setup variable can be viewed by typing its name.

E.g. "STATION NAME" will show the current station name.

Every setup variable can be changed by typing its name = new value.

E.g. "STATION NAME = SUTRON" will set the station name to "SUTRON".

[AUTO OUTPUT](#)
[AUTOMEASURE INTERVAL](#)
[AUTOMEASURE TIME](#)
[AUTOPURGE ENABLE](#)
[AUTOPURGE INTERVAL](#)
[AVG TIME](#)
[BLOCKAGE DETECTION](#)
[BLOCKED FLOW](#)
[BLOCKED PRESSURE](#)
[BUBBLE RATE](#)
[BUBBLE 2 RATE *](#)
[BUBBLE UNITS](#)
[C0+](#)
[C1+](#)
[C2+](#)
[DELAY AFTER TX](#)
[DELAY BEFORE TX](#)
[FIELD CAL OFFSET](#)
[FIELD CAL 2*](#)
[GARMIN GPS](#)
[GPS LOCAL TIME OFFSET](#)
[HARDWARE FLOW CTRL](#)
[LEVEL RIGHT DIGITS](#)
[LEVEL UNITS](#)
[LOG ACCUBAR PRESSURE](#)
[LOG BATTERY](#)
[LOG DAILY VALUES](#)
[LOG DQAP SAMPLES](#)

[LOG TEMP IN BOX](#)
[MEAS NAME](#)
[MODBUS BAUDRATE](#)
[MODBUS DEVICE ID](#)
[MODBUS ENABLE](#)
[MODBUS PARITY](#)
[MODBUS PROTOCOL](#)
[OPERATING MODE](#)
[ORIFICE CONFIG*](#)
[ORIFICE SEPARATION*](#)
[PURGE LENGTH](#)
[PURGE PRESSURE](#)
[R0+](#)
[RS232 WAKEUP](#)
[SDI DATA OLD](#)
SDI ADDRESS
[SEPARATION UNITS](#)
STATION NAME
[STEIN A+](#)
[STEIN B+](#)
[STEIN C+](#)
[TEMP UNITS](#)
[TUBE ID](#)
[TUBE LENGTH](#)
[USER OFFSET](#)
[USER SLOPE](#)
[WATER TEMP](#) ENABLE+
[WATER TEMP](#) TYPE+

Commands followed by a * indicate Dual Orifice Bubbler only commands.
Commands followed by a + indicate a water temperature setting.

Setup Transfer via Hyperterminal

It is possible to capture a Bubbler's setup and save it to file. Using HyperTerminal, establish [RS232 connection](#) first. Once you are able to talk to the Bubbler, use HyperTerminal's Transfer menu and select Capture Text. Then type !SETUP on the command line. The Bubbler will stream out its entire setup and it will be saved in the file selected. Make sure to tell HyperTerminal to stop text capture after getting the setup in the file. Alternatively, a setup file can be saved to [SD card](#).

Once the setup is saved to file, feel free to edit the file, changing any of the settings. To send a setup file to the Bubbler, HyperTerminal will need to be properly configured to delay after sending every line. To do so, user HyperTerminal's **File, Properties** menu. Click on the **Settings** tab and click the **ASCII Setup** button. Change the **Line delay to 1000 milliseconds** and change the **Character delay to 5 milliseconds**. If these changes are not made, HyperTerminal will send the file too fast for the Bubbler to capture any but the first few settings. Once the changes are made, choose HyperTerminal's Transfer menu and click **Send Text File**. Select the file with the saved setup. You will see the transfer take place on HyperTerminal's main window. Bubbler will report which settings have been changed.

Connecting a Modem

It is possible to connect a modem to the Bubbler, allowing for remote access to the station. Use the [RS232](#) port to connect the modem. Most modems will need a null modem adapter between the modem and the Bubbler.

The modem will need to be configured before it can be used. Please make sure to test out the modem-Bubbler connection before deploying them in the field. The following modem settings must be configured:

- **Autoanswer: enable** (otherwise a connection will never be established)
- **Connect timeout: enable** (otherwise the modem will keep the Bubbler awake, increasing power consumption)
- **Command echo: disable** (otherwise the modem and the Bubbler will forever talk to each other, preventing further connections and increasing power consumption)
- **Telnet mode: enable** (this is required only if using a modem over TCP/IP – if not enabled, log downloads may fail, especially if using HyperTerminal)
- **RTS: enable** (this is likely on by default – the Bubbler will not notice the modem unless RTS is on)
- **Carrier Detect: always on** (also know as LSD Action, DCD, and CD)
- **Baud rate, parity, etc:** set this up to match the [settings of the Bubbler](#) (Bubbler defaults are 115200 Baud, no parity, 8 data bits, 1 stop bit)

Xpert-Xlite Modem 8080-0005

Sutron manufactures a modem (Xpert-Xlite Modem part number 8080-0005) that is suitable for use with the Bubbler. On the Bubbler, setup [RS232 Wakeup](#) to wake on RTS (it is that way by default).

A null modem cable is needed between the device and the modem since they are both configured as DCE devices. If the null modem cable routes pin 9 through from end to end, you can power the modem from the device, but most null modem adapters leave pin 9 disconnected. In that case, just connect the power (5V-16V DC) to the power connector. Note: this can be done even if the cable routes power through pin 9. The modem will utilize which ever is providing the higher voltage. The modem also must be configured to power up on RTS instead of DTR and to output CD on the DSR pin.

Set J4 to pins 1-2 to have the modem wake up on RTS

Set J5 to pins 1-2 to route CD out the DSR pin

The default settings from Sutron for the modem will work. If the settings have been changed, issue these commands to the modem:

```
AT&F
ATS0=1
ATE0Q1&D0&W
```

This is what the commands mean:

```
AT&F set to factory defaults
S0=1 answer on first ring
E0 don't echo characters
Q1 don't send result codes
&D0 ignore DTR
&W save settings into profile.
```

Raven Modem

A Raven modem allows you to access the bubbler through the internet. The Raven should be ordered with a fixed IP address. Using that IP address, you will be able to use HyperTerminal or other TCP/IP aware communications programs to use the command line interface of the Bubbler. Make sure to place a null modem adapter between the Raven and the Bubbler.

The Raven modem must be configured as follows:

Device Port	3001
Configure Serial Port	115200,8N1
Command Echo	0
TCP Auto Answer	2
TCP Connect Timeout	30
TCP Idle Timeout	2
Telnet Echo Mode	0

You can connect the Raven to the same battery powering the Bubbler; however, remember that it will increase the power consumption (both when the modem is idle and when it is connected). As a result, you will need to make sure your battery is large enough to provide the power needed by the station.

RS-485

The Bubbler can be interfaced to via RS485 A and B connections on the front panel using the SDI-12 protocol.

The Bubbler only supports the SDI-12 protocol over the RS485 connection. No settings need to be changed to use SDI-12 over RS-485. The Bubbler does not support connections over both the RS485 and the SDI-12 lines at the same time.

MODBUS over RS485 is NOT supported.

Installation

Mount the enclosure

The Bubbler is designed to mount vertically against a wall or other surface. In this configuration, the orifice line connection points down. Do not simply place the bubbler on a bench or table top. The vertical mounting helps prevent any moisture from forming inside the bubbler tubing. If not mounted vertically, the Accubar sensor will be negatively affected.

The Bubbler mounts to a panel or surface through four holes that are accessible in the corners of the fiberglass enclosure

Tubing/Orifice Installation

The Bubbler OUTLET pressure fitting accommodates an 3/8" OD tubing that will run down into the water. The 3/8" tubing provided by Sutron can be installed directly on the ground, buried in the ground or in a conduit. When running the tube to the water, try to ensure that the line is run with a continuous downward slope. If there are low points in the line and moisture collects there, you may get erroneous readings. For the greatest accuracy, the maximum length of orifice line to use with the Bubbler is 500 ft. The following table shows the expected pressure drop in 1/8" I.D. tubing due to movement of air through tubes 500 ft and longer:

Feet of tubing	Flow Rate in CC/min	Pressure error in ft H2O
500	5	0.025
500	15	0.075
1000	5	0.05
1000	15	0.15
2000	5	0.10
2000	15	0.30

The tube should be fitted with a suitable orifice in the water. The orifice should be firmly attached a wall, rock or weight so it doesn't move.

The orifice should be installed in water that is relatively still and free from currents. If there are currents in the area of the orifice, the currents will cause a shift in the pressure reading.

The tube is connected to the Bubbler using a Swagelok fitting. They can be assembled in three simple steps.

Step 1

Insert the tubing into the Swagelok tube fitting. Make sure that the tubing rests firmly on the shoulder of the fitting and that the nut is finger tight.

Step 2

Before tightening the Swagelok nut, scribe the nut at the 6 o'clock position.

Step 3. Hold the fitting body steady with a backup wrench and tighten the nut 1 ¼ turns. Watch the scribe mark make one complete revolution and continues to the 9 o'clock position.

Once the Swagelok fitting has been installed, it can be disconnected and retightened many times. To retighten:

1. insert the tubing with the pre-Swaged ferrule into the fitting body until the front ferrule seats.
2. tighten the nut by hand.

3. tighten with a wrench about ½ turn.

Electrical connections

Refer to Chapter 3 on Cabling for a description of the electrical connections.

Bubbler Setup

Most sites will need, at a minimum, the following settings during installation. The settings can be entered using either the front panel or RS232 port.

Station name
Bubble rate
Desired units and right digits
Automeasure time and interval

Other settings are used as needed for a specific site.

Check for Leaks

Leaks inside the Bubbler can be a source of inaccuracy and/or excessive pumping and use of desiccant. To check for leaks, you must cap the outlet or orifice and run the built-in leak test routine. Sutron provides a cap with each unit that can be used to cap the outlet for the leak test. When the leak test completes, the system will display a status indicating whether the unit has passed or failed the leak test along with a score.

Purge Line

After connecting the outlet line to the bubbler, issue the [purge](#) command. The command turns on the pump and builds pressure to a user set pressure (default 50 PSI) and then opens the restrictor bypass valve to force the pressurized air to the outlet. The pump will continue to run for a user set period (default 30 seconds) and then turn off the pump and allow the pressure to bleed out the line.

Field Calibration

Users normally will want the water level (Stage) to be referenced to some external level, perhaps Mean Sea Level, or some other reference. This is normally done by pressing SET when the water level is displayed and then typing in the current level for the stage. The user must get this current level from an external staff gauge or some other means of determining the level. When this current level is entered, the software calculates a FIELD CALIBRATION OFFSET which is used to compute the value that is displayed. If you do not do the field calibration, the system will simply report the level above the orifice. If the orifice is not under water during a calibration, enter the level of the orifice when prompted for a value.

The procedure for Field Calibration is a bit different for the different orifice configurations:

Single – calibration is performed as described above.

Dual Separate – calibrate both Stage and Stage2. The system has a separate offset for each level.

Dual Density – if you have accurately measured the orifice separation and entered the value into the system, you should only need to calibrate Stage. However, if it is difficult to accurately measure the separation of the orifices, you can have the system compute the separation automatically by calibrating the density. When the density is displayed, press SET and then enter the density. The system will then automatically compute the

separation between the orifices. The following table gives the density of pure water based on temperature. Remember that line 2 must be below line 1 for the system to properly measure the density.

Temp	Density
0 C 32F	.9999
5 C 41F	1.000
10C 50F	.9997
15C 59F	.9991
20C 68F	.9982
25C 77F	.9970
30C 86F	.9957

The density of Seawater is generally between 0.1020 to 0.1030.

Dual Expanded – calibration of the levels in the dual expanded configuration takes into account the situation where one or both of the sensors is too deep to calibrate or in the open air. In the case where the sensor is too deep to calibrate, the system will notify you of the fact and ask you to enter the offset directly – it will not make a measurement and compute the offset for you. Otherwise, the system will make a measurement and ask you for the current level. If the sensor is in the air, enter the level of the sensor and not the water level. Please note that in this mode, *the Bubbler will not make any measurements until the user sets the water level.*

Factory Calibration

The Bubbler undergoes a rigorous screening and testing at the factory before they are shipped to ensure that they meet their accuracy specifications over temperature and that they are stable both in zero and span and will continue to be accurate over time. The span drift of the Bubbler in the field is typically less than 0.01% per six months. This is a small fraction of the stated accuracy of the Bubbler. The stated accuracy of the Bubbler at its full scale reading is 0.1% of reading, although typically it is much better. Even though it would typically take over 5 years for the Bubbler to drift as much as 0.1%, it is recommended that the Bubbler, like all precision measurement instruments, be calibrated annually. See additional details in the [maintenance section](#) on page 72 of the manual.

Hostile Conditions

(from the IOC Manual on Sea Level Measurement and Interpretation: Volume II – Emerging Technologies)

Effect of Waves

Surface waves will produce a rapid cyclic change in pressure in a bubbler system. The error so produced is dependent on wave amplitude in the following relations

$$E = \frac{V}{A} \frac{S}{P_o}$$

where E = error

V = total system volume

A = horizontal cross sectional area of pressure point

S = pressure amplitude of short period wave

P_o = water head pressure at outlet below trough of a wave

Effect of Currents

Areas of strong currents should be avoided when siting bubbler measuring systems. The presence of a pressure point in the tidal current will distort the velocity field, so that the pressure sensed cannot be interpreted simply as the undisturbed hydrostatic pressure. Depending on whether the bleed hole faces into or away from the current the measured pressure will be greater or less than the hydrostatic pressure. If a

pressure point has to be fixed in strong currents it should be positioned so that the bleed hole is tangential to the main current flow to minimize the error

Density Variations

Since the water levels measured by pressure systems are a function of the water pressure at the pressure point outlet, variations in the water density can lead to errors in both bubblers and direct reading systems. Such density variations are most pronounced at sites situated close to or on river estuaries. If an estuarine site must be used, specific gravity measurements should be taken and corrections applied.

Troubleshooting and Maintenance

Troubleshooting

The following checklist will help in troubleshooting problems:

Problem	Possible Cause
Pressure dropping/ excessive pump operation	Run leak Test. Observe error codes and refer to “Hardware Error Codes” section to determine source of problem.
	Make sure orifice lines are fully attached and tight on the Bubbler orifice ports.
Pump not running	Check the battery voltage.
	Run Purge Test. If the pump never comes on, look at the hardware error codes to see what the problem is.
Incorrect stage	Check for bubbles out of the orifice during normal operation. (not during purge test)
	Lookup any error codes on the front display and address the associated issue.
No Density Value	Make sure both orifice lines are below water with some vertical separation between the orifice lines. Line 1 should be higher than line 2.
	Check setup to make sure it is set to density type.
	If value takes a long time to appear, check the averaging time in the setup.
No data	Faulty wiring – check all wiring and terminations
	No power – check fuse in the data recorder and power at sensor. There is no fuse in the sensor itself.
	Wrong address requested -- make sure the data recorder is set up to request data at the proper address
	Wrong address set in sensor -- use the identify command to make sure the sensor is responding to the proper address, if not double check the SDI-12 address using the front panel.
	Command or address is wrong case – all Bubbler commands are capital letters, make sure address is proper case and commands are upper case.
Garbled data	Multiple sensors set to the same address -- check address settings of all SDI sensors. Remove all other sensors from the recorder and add them one at a time.
	Command issued to a wild card address (* or ?). Remove all other sensors from the recorder and try again.
Erroneous data	Wrong units selected. Verify that the desired units are selected.
	High unstable readings when bubbler is utilized – Unit has not been configured for use at the site. Please refer to the Installation chapter to configure the unit for the site.
	High unstable readings when bubbler is utilized – Water in the orifice line. Have the Bubbler do a purge.
	Low readings when bubbler is utilized – Check for leaks in the system by using the leak test.
	Erroneous offset entered – check the field calibration offset

Erroneous user scale and offset entered.
--

If you are having problems with the bubbler after using the above guide, set the Advanced Settings/Log Diagnostics = enabled. This will cause the system to write diagnostic information to the log. Let the system operate for at least 10 minutes and then retrieve the log and analyze it to better understand the problem. You may also e-mail the log file to Sutron's customer service department to help understand how the system is operating.

Hardware Error Codes

The Bubbler may record one of the following error values during its operation. The error codes may be returned in response to some SDI-12 commands, or may be shown on the front panel.

Error Code	Description
4001	restrictor sensor failure
4002	tank sensor failure
4003	temperature sensor failure
4004	pressure did not increase during pumping
4005	negative tank pressure
4006	pressure did not normalize during bleeding
4007	internal software error
4008	venting did not decrease pressure
4009	battery low
4010	battery low during pump
4011	Accubar sensor fail
4012	Accubar not calibrated
4013	failed to attain pressure
4014	line sensor overpressure
4015	Accubar autozero out of range
4016	timeout emptying tank
4017	Accubar and tank sensor readings did not match
4018	restrictor not zero
4019	restrictor valve stuck open
4020	restrictor valve stuck closed
4021	restrictor pressure dropped too fast
4022	restrictor pressure dropped too slow
4023	line valve stuck open
4024	line valve stuck closed
4025	leak test low pressure fail
4026	leak test high pressure fail
4027	SD card failure
4028	restrictor autozero out of range
4029	Accubar autozero twin
4030	rest2 sensor failure
4031	tank2 sensor failure
4032	leak test 2 lo failed
4033	leak test 2 hi failed
4034	restrictor valve stuck open 2
4035	restrictor valve stuck closed 2
4036	restrictor flow too fast 2
4037	restrictor flow too slow 2
4038	Accubar valve stuck open 2
4039	Accubar valve stuck closed 2
4040	tank valve stuck open
4041	tank valve stuck closed
4042	Accubar sensor failure 2
4043	temperature sensor out of range
4044	pump watchdog
4045	Accubars different
4046	Water Temp sensor reading exceeds range -40 to +60°C

Maintenance

The Bubbler is designed to operate for extended periods with very little or no maintenance required. If a site visit is needed for any reason, it is a good idea to perform a routine maintenance check of the encoder. Some easy to follow guidelines are listed below.

1. Check the desiccant at each visit (every 3 months). If the desiccant is more than ½ pink, replace with fresh desiccant. The new desiccant will be blue. See the section [desiccant life](#) on page 72 for more information on how long the desiccant will last. To disconnect the tube from the quick disconnect fitting, push the fitting collar around the tube flush against the fitting and pull on the tube.
2. Perform a visual inspection of the unit. Note any abnormalities such as external oxidation, rust.
3. Check the wiring to make sure it is not corroded, frayed, or loose.
4. Examine pump runtime. Verify runtime is reasonable (less than 5 min/day at 5SCCM). The purge and leak tests may help determine the cause of the excessive runtime.
5. Run a purge to verify the pump and internal tubing are intact. If the purge fails to reach the desired pressure, check the tubing from the outlet of the pump (red barb) to the check valve (at top of pump).
6. Run a leak test if possible to verify there are no internal leaks.
7. Download the data and events. Examine the log for any abnormal readings or events.

Desiccant Life

The following table shows the desiccant life a function of flow rate and humidity. For example, at a setting of 5 SCCM, no purges, the desiccant will last for 12.2 months at an area of 50% average humidity and 30C average temperature. The desiccant will last 11.3 months if there are 60 second purges once a week.

Desiccant Life calculation			Life in Months for Silica Gel desiccant based on Flow (SCCM) -- no purges Flow (SCCM)			
Humidity %	Temp - C	Vapor gm/m3	5	10	15	20
50	25	11.5	16.2	8.1	5.4	4.0
50	30	15.2	12.2	6.1	4.1	3.1
50	35	19.8	9.4	4.7	3.1	2.3
75	25	17.3	10.7	5.4	3.6	2.7
75	30	22.9	8.1	4.1	2.7	2.0
75	35	29.8	6.2	3.1	2.1	1.6
90	25	20.8	8.9	4.5	3.0	2.2
90	30	27.4	6.8	3.4	2.3	1.7
90	35	35.8	5.2	2.6	1.7	1.3

			Life in Months for Silica Gel desiccant based on Flow (SCCM) - 60 sec purge 1/week Flow (SCCM)			
Humidity %	Temp - C	Vapor gm/m3	5	10	15	20
50	25	11.5	14.9	7.8	5.2	4.0
50	30	15.2	11.3	5.9	4.0	3.0
50	35	19.8	8.7	4.5	3.0	2.3
75	25	17.3	9.9	5.2	3.5	2.6
75	30	22.9	7.5	3.9	2.6	2.0
75	35	29.8	5.8	3.0	2.0	1.5
90	25	20.8	8.2	4.3	2.9	2.2
90	30	27.4	6.3	3.3	2.2	1.7
90	35	35.8	4.8	2.5	1.7	1.3

Desiccant has a capacity of 44.6 grams water
Purge assumes flow of 5 litres/minute
Vapor densities from hyperphysics web site

When operating a bubbler with two orifices, compute the combined desiccant life by adding together the life for each line and dividing by 4. For example, if line 1 and line 2 were both set for 5 SCCM (60bpm) the life would be 10.7 months at 25C, the combined desiccant life would be (10.7+10.7)/4= 5.2 months.

Factory Calibration

The initial factory calibration of the Accubar pressure sensor typically includes over 1000 different pressure temperature points that cover the complete temperature range from -40 to +60 degrees C and cover the complete pressure range from 0 to 25 PSI for the 5600-0133-25. This ensures that the Bubbler meets the specifications over the complete pressure and temperature range. A calibration verification encompasses nearly 200 points over the complete temperature and pressure range. The Bubbler Accubar sensor can be sent back to the factory for a complete re-calibration over temperature or a simpler calibration check. Since the calibration data is stored in the small sensor module, you can freely swap or interchange Accubar sensors into different BUBBLERS. Sutron recommends an annual check of the Accubar calibration.

Accubar Replacement

The Accubar can be easily replaced. After acquiring a new sensor from Sutron, power down the Bubbler, open the front panel, unplug and remove the old Accubar and replace it with the new Accubar.

FIRMWARE Upgrade

Sutron's CF Bubbler has been designed using the most modern techniques such that at any time the system firmware may be upgraded while it is in the field preventing the need to ever return a unit to the factory for firmware upgrades. The factory may offer new features or bug fixes that may only be accessed through firmware upgrades. The techniques below will illustrate how to install the upgraded firmware into the unit.

Methods for upgrade:

There are several possible methods to use to upgrade the software in the unit. The first step in all methods is to download from the Sutron web site the program upgrade file, such as 'v1_24mainBubbler1265.upg', found at <http://www.sutron.com/downloads/software.htm>. Select the CF Bubbler and download the UPG file to a temporary folder or desktop location where it may be accessed at a later time.

Bubbler can only be upgraded via the RS-232 port.

A terminal emulator program such as HyperTerminal or TeraTerm is required to upgrade Bubbler firmware. The program must support Ymodem file sending.

For TeraTerm, please use Version 4.85 or below, as a Ymodem bug was introduced in later versions.

Method 1: Using 'UPGRADE' command using terminal emulator:

Open and run terminal emulator on a PC. Set the properties to:

Baud Rate: 115200
Bits: 8
Parity: None
Stop Bits: 1

- Start with the unit powered up and running.
- Connect DB-9 serial cable and establish communications by typing 'enter'. (connect port)
- Once the prompt is found, type 'UPGRADE' or 'UPG'.
- Now the system is waiting for HyperTerminal to send the file.
- An upper case "C" will repeat every 2 seconds or so over the serial port. Select 'Send File' and choose 'Y-Modem' and then select the upgrade file name previously stored on the computer.
- Once the download is completed, the system will reboot.
- Type the command 'Ver' to confirm that the upgrade was successful

Method 2: Using terminal emulator and 'Escape' key:

This method should be used if a previous upgrade attempt was aborted, resulting in the Bubbler main application not working. The Bubbler bootloader may still be used to upgrade the main application.

Open and run terminal emulator on a PC. Set the properties to:

Baud Rate: 115200
Bits: 8
Parity: None
Stop Bits: 1

- Start with the unit powered DOWN.
- Open the serial port with the terminal emulator.
- Power up the unit simultaneously while holding the 'Escape' key on the keyboard of the computer running the terminal emulator. Release the escape key once the unit has powered up.

- An upper case “C” will repeat every 2 seconds or so over the serial port. At this time, use ‘Send File’ and choose ‘Y-Modem’ and then select the upgrade file name previously stored on the computer.
- Once the download is completed, the system will reboot.
- Type the command ‘Ver’ to confirm that the upgrade was successful.

GPS

It is possible to use a GPS to provide the Bubbler with an accurate, self setting clock. Bubbler can be connected to a Garmin GPS 16HVS. Bubbler needs to have software **version 1.24** or newer to support GPS.

Timekeeping

When equipped with a GPS, the Bubbler will keep UTC time. UTC (Universal Coordinated Time) is an internationally accept time standard. UTC will differ from the local time by a number of hours. The user can setup the Bubbler so that it keeps local time by changing the variable Local Time Offset. To get EST, set the local time offset to -5 hours.

If a Sutron Satlink (versions 6.17 and newer) is connected to the Bubbler via SDI-12 (in addition to the Garmin GPS), note that Satlink will set the clock of the Bubbler once per day. **Please ensure that Satlink's local time offset is equal to that of the Bubbler.**

An Bubbler equipped with a GPS will provide a timing accuracy of ± 1 second.

GPS Installation and Setup

When first installing the GPS, make sure the GPS is positioned so that it has a clear view of the sky. Make sure to connect the GPS to the Bubbler via RS232. Sutron provides a custom RJ45 to RS232 connector for this purpose (the diagram for the connector is on page 78).

After connecting the two devices, go the **Station Setup** menu on the front panel of the Bubbler. Find the entry called *Garmin GPS* and press set to enable the GPS. Then go back to the top of the menu, and hit the down button until the **GPS status menu** is shown. If the Bubbler is communicating with the GPS, the menu will say

GPS initializing. If the GPS has acquired a time fix, the Bubbler will show *GPS functioning*.

Pressing right in the GPS status menu will provide more details.

If the GPS has locked on satellites and is providing accurate time, the menu will show a message such as

GPS has valid time
5 satellites used in time fix

Pressing down from the detailed status menu will show the **last GPS time sync**. The time show is the time when the GPS last had a time fix. If it has been more than 12 hours since the last valid time fix, the GPS is not working properly and may need to be repositioned (please see page 77).

The next entry in the menu is **local time offset**. The user can setup the Bubbler so that it keeps local time by changing the variable Local Time Offset. To get EST, set the local time offset to -5 hours.

When installing, it is recommended that the user wait until the GPS has valid time before leaving the station. If the GPS does not acquire the time in ten minutes, the GPS should be repositioned so that it has a better view of the sky.

Keep in mind that whenever the display is turned on, Bubbler will power up the GPS. This helps with GPS positioning. As long as the display is on, the Bubbler will provide power the GPS, allowing it to track satellites. When the display is off, the Bubbler will power the GPS once an hour for up to 15 minutes.

GPS Positioning

If the Bubbler is reporting that the **GPS cannot get a time fix**, it means that the GPS is unable to get a clear view of the sky. It could also be the case that the GPS is picking up interference. The best solution is to reposition the GPS. The GPS needs to have a **clear view of the sky** in order to properly function.

Place the GPS antenna in the most open space possible. Do not place it directly under anything nor directly beside something. Always attempt to achieve a "full sky" view with the antenna.

Place the GPS antenna high up on a pedestal or in a protected location. Flat surfaces may tend to cover with ice and snow more so than elevated locations. Keep away from areas where birds may nest. Placement is very important and great care should be taken in selecting the location.

GPS Operation

Once every hour, the Bubbler will wake up the GPS. Once the GPS has acquired a time fix (should not take more than 40 seconds), the Bubbler will set its clock and put the GPS in low power mode. Powering the GPS once an hour provides the optimal power consumption.

In addition, whenever the display is turned on, Bubbler will power up the GPS. This allows the user to see whether the GPS can acquire a time fix and helps in positioning the antenna.

GPS Errors

If the GPS is either not communicating with the Bubbler or if the GPS cannot acquire a time fix, the Bubbler will blink the red LED to indicate that there is a problem. In addition, the Bubbler will show a message describing the problem on the front panel. Once a day, the Bubbler will write an event to the log indicating that it has GPS problems.

The Bubbler reporting "**No GPS Detected**" can indicate that the connector between the GPS and Bubbler is bad (please refer to the section on the connector on page 78) or that the Bubbler does not have its jumpers set properly (please see the section on page 77 about Jumpers)

If the **GPS cannot get a time fix**, please see the section on GPS Positioning on page 77.

If the Bubbler reports "**GPS Comm Failure**", it means the Bubbler is detecting data on the RS232 line, but that the data is incomprehensible. It could indicate that the GPS has been improperly configured. If possible, try using a different GPS module.

If a faulty GPS is connect to the Bubbler, of it the GSP is not connected to the Bubbler, the Bubbler will take a full minute before deciding it cannot talk to the GPS. Ensure that the Bubbler is given enough time to talk to the GPS before leaving the station.

Jumpers

There is a jumper inside the Bubbler that ensures that the Bubbler provides 12 Volts on RS232 which the Garmin GPS requires in order to function. **If the Bubbler is reporting "No GPS Detected"**, it may be the case that the jumper is not properly setup.

To setup the jumper, the case must be opened. Once the case is open, the jumper is easily accessible. The Jumper in question is J19, and is located next to the RS232 connector. Place a connector on jumper J19 so that it connects 12v to the middle pin (pins 1 and 2)

In addition to J19, there is another jumper needs to be properly configured in order for the unit to provide power to the GPS. However, this jumper is properly setup at the factory and it is unlikely to be the cause of the problem. The jumper in question is J16 (located next to J19). It should have a connector across pins 2 and 3 or have no connector at all.

RJ45 to RS232 Connector

A custom connector is required to get the Sutron and the Garmin GPS together. The connector bridges the RJ45 on the Garmin GPS to the RS232 on the Sutron unit. The table below provides the wiring diagram for the connector.

Note: The colors on the Garmin GPS RJ45 **do not match** the colors of the RJ45 to RS232 converter.

Rj45 pin Garmin plug color	RJ45 to Rs232 converter	RS232 on Sutron unit	Function	comments
1 Red	Blue	9	Power	8 to 40V for 16HVS
2 Black	Orange	5	Ground	
3 Yellow	Black	8 CTS	Remote power on/off	On if <0.3V, Off if open circuit
4 Blue	Red	2	Port 1 Data in	NMEA input to GPS
5 White	Green	3	Port 1 Data out	NMEA output from GPS
6 Gray	Yellow	no connect	PPS	1Hz
7 Green	Brown	no connect	Port 2 Data in	RTCM output
8 Violet	White	no connect	Port 2 Data out	reserved

Modbus

The Bubbler can be configured as a Modbus server device. In this mode, the unit will respond to properly formed Modbus messages in either RTU (default) or ASCII format. Keep in mind that when Modbus has been enabled, the unit will not be capable of connecting to a PC/PDA to download a log or make setup changes, but AutoPoll can be used to access log data. For more information on AutoPoll, please visit www.sutron.com

To enable Modbus, go to the **Station Setup** menu on the front panel and press right when the **Modbus Setup** option is shown. The first option shown is the current status of Modbus, enabled or disabled. Pressing Set will switch between the two options. If Modbus is disabled and it is turned on, a warning message will display showing that GPS and PC communications will cease to work. Hitting Set will enable Modbus.

Modbus Menu Options

After enabling Modbus, other setup options become available allowing more customization of the unit. Initially, each of these settings is defaulted to those expected by the Modbus protocol.

Modbus Enabled

Default is DISABLED. Enabling will cause the unit to not communicate properly with any other type of device on the DB9 connector for example a PC/PDA or Garmin GPS unit.

Modbus Device ID

Default is 1. The device ID is the address that is used by the Modbus client to select which device to communicate with. Each server on the bus must have a unique device ID ranging from 1 – 247. Address '0' is reserved as the broadcast address.

Modbus Protocol

Default is RTU. There are two protocols available to the user, RTU and ASCII.

In RTU mode a compatible Modbus client device must generate messages, as strict timing is required for a successful communication. This mode allows for better data throughput than ASCII mode for the same baud rate.

When using Modbus over a radio, use ASCII rather than RTU mode. Radios tend to break up Modbus data packets as they are sent over the air. Since RTU does not allow for a timeout between the bytes of the packet, communications errors occur.

In ASCII mode, the user may connect to the device using a serial communication program (i.e. HyperTerminal or ProComm) set to 7 data bits and 1 stop bit. Messages can then be sent to the unit by typing the proper command. Each command is prefixed with a ':' and ended with a carriage-return / line-feed (<CR><LF> usually just the 'Enter' key). This mode offers much less throughput than RTU since 2 ASCII characters are required to describe a single binary byte (e.g., the value 0xB5 would be communicated by sending the ASCII characters 'B' and '5'). Since a Cyclic Redundancy Check (CRC) is required on each message, the ability to send the message via HyperTerminal is almost of no use unless the CRC can be generated by the user.

Note: Care must be taken to make sure the selected protocol matches that of the client or there will be communication problems.

Modbus Parity

Default is Even. Available choices include Even, Odd and None.

Note: Care must be taken to make sure the selected parity matches that of the client or there will be communication problems.

Modbus Delay before Tx

Default is 10ms. This identifies the number of milliseconds to wait after asserting CTS before starting data transmission. This is useful if the device is connected to a radio requires keying initialization before data transmission. The possible delay ranges are 10ms – 2000ms.

Modbus Delay after Tx

Default is 10ms. This identifies the number of milliseconds to wait after data transmission is complete before de-asserting CTS. This is useful if the device is connected to a radio that requires a hold-off time after data transmission has completed. The possible delay ranges are 10ms – 2000ms.

Modbus Baud Rate

Default is 19.2 Kbps. Available communication speeds range from 1200bps – 115 Kbps.

Note: Care must be taken to make sure the selected speed matches that of the client or there will be communication problems.

Modbus Function Codes

The following table identifies the functions that are supported. Each diagnostic counter is cleared when the device is powered up or reset.

Code	Hex	Subcode	Hex
Read Holding Registers	0x03		
Read Input Register	0x04		
Write Single Register	0x06		
Diagnostic	0x08	Return Query Data	0x00
Diagnostic	0x08	Clear Counters	0x0A
Diagnostic	0x08	Return Bus Message Count	0x0B
Diagnostic	0x08	Return Bus Comm Error	0x0C
Diagnostic	0x08	Return Bus Exception Count	0x0D
Diagnostic	0x08	Return Server Message Count	0x0E
Diagnostic	0x08	Return Server Broadcast Count	0x0F
Diagnostic	0x08	Return Bus Char Overrun Count	0x12
Write Multiple Registers	0x10		
User Defined Code	0x41	GetLog	GL

Identifying Registers

There are two types of data that can be accessed using the Modbus protocol. These include *Holding* and *Input* registers.

Holding Registers

Holding registers are reserved for the purpose of setting and getting data such as the date and time and diagnostic counts if the ability to send the above *Diagnostic (0x08)* command is not available. The following table identifies the holding registers and their locations. Each of these registers is an unsigned 16-bit value (if readings registers using an Xpert, set the data type to *ushort*).

Data	Register	Valid Data Values
Hour of current time	1001	0 – 23
Minute of current time	1002	0 – 59
Second of current time	1003	0 – 59
Year of current time	1004	> 2000
Month of current date	1005	1 – 12
Day of current month	1006	1 – 31
Recording status	1007	1 means running 0 means stopped
Reset Unit	1008	Write 1 to reset
Modbus Protocol	1009	0 – RTU 1 – ASCII
Force Measurement *	1010	0 – force all active measurements 1-16 force that measurement only
Bus Message Count	1011	Read Only
Bus Comm Error	1012	Read Only
Server Exception Count	1013	Read Only
Server Message Count	1014	Read Only
Broadcast Message Count	1015	Read Only
Char Overrun Count	1016	Read Only
Modbus Enable	1022	Read/Write 0=OFF 1=ON

**Note: When forcing a measurement, be sure to wait the proper amount of time for a measurement to finish before requesting data.*

Input Registers

Input registers return the last measured data from the device including stage, discharge, today and yesterday's volume and battery voltage. Ideally these values should be requested on a schedule slightly lagging the measurement schedule on the Bubbler. This will ensure data will follow that found in the Bubbler log. If the last measured data is not acceptable, a live reading can be forced by writing a '1' to the *Force Measurement (1010)* holding register. Care must be taken to allow enough time to pass for taking a measurement before requesting the data, especially if an analog reading is being taken.

Since the unit works with floating point numbers and Modbus only allows for 16-bit registers, a multiple register read can be used to access the entire reading. The Modbus client device should be configured to treat these reads as a single floating point number. For example, if accessing *Last measured Stage* via an Xpert, read 1 value of type *float* starting at register 1. If the quality is also desired, change the number of values to 2 and choose *ushort* for the second reading type. The complete list of registers and their locations are below.

Data	Register
------	----------

Bringing the Benefits of Real-Time Data Collection to the World

Sutron Corporation, 22400 Davis Drive, Sterling, Virginia 20164

Last measured water level (MSW)	1
Last measured water level (LSW)	2
Quality of water level (see below)	3
Last measured water level in PSI (does not apply field calibration offset or autozero) (MSW)	4
Last measured water level in PSI (does not apply field calibration offset or autozero) (LSW)	5
Quality of water level (see below)	6
Last measured temperature in Celsius (MSW)	7
Last measured temperature in Celsius (LSW)	8
Quality of temperature (see below)	9
Last measured restrictor pressure (MSW)	10
Last measured restrictor pressure (LSW)	11
Quality of restrictor (see below)	12
Last measured tank pressure (MSW)	13
Last measured tank pressure (LSW)	14
Quality of pressure (see below)	15
Battery Voltage (MSW)	16
Battery Voltage (LSW)	17
Last measured water level 2 (MSW)	18**
Last measured water level 2 (LSW)	19**
Quality of water level 2 (see below)	20**
Last measured water level 2 in PSI (does not apply field calibration offset) (MSW)	21**
Last measured water level 2 in PSI (does not apply field calibration offset) (LSW)	22**
Quality of water level (see below)	23**
Last measured temperature 2 in Celsius (MSW)	24**
Last measured temperature 2 in Celsius (LSW)	25**
Quality of temperature 2 (see below)	26**
Last measured Density (MSW)	27**
Last measured Density (LSW)	28**
Quality of Density (MSW)	29**
Last measured restrictor 2 pressure (MSW)	30**
Last measured restrictor 2 pressure (LSW)	31**
Quality of restrictor (see below)	32**
Last measured tank 2 pressure (MSW)	33**
Last measured tank 2 pressure (LSW)	34**
Quality of pressure (see below)	35**
Last measured water temperature (MSW)	36+
Last measured water temperature (LSW)	37+
Quality of water temperature (see below)	38+
Last measured density from water temp (MSW)	39+
Last measured density from water temp (LSW)	40+
Quality of density from water temp	41+
Last measured suspended sediment (MSW)	42!
Last measured suspended sediment (LSW)	43!
Quality of suspended sediment	44!
DQAP Stage MSW	45
DQAP Stage LSW	46

DQAP Standard Deviation MSW	47
DQAP Standard Deviation LSW	48
DQAP Keepers	49
DQAP Outliers	50
DQAP 15 second average (MSW)	51
DQAP 15 second average (LSW)	52
DQAP 60 second average (MSW)	53
DQAP 60 second average (LSW)	54
DQAP Quality	55

*Quality – the quality register will hold the value 1 if the reading is valid, and the value 0 if an error occurred during the reading.

** These registers are valid for Dual Orifice Bubbler units only.

+ These registers require a Bubbler that can measure [water temperature](#).

! These registers require a -3 dual orifice Bubbler with a water density sensor and a water temperature sensor.

DQAP These registers require the Bubbler to be in DQAP mode.

Get Log Command

The Get Log subcode is used to retrieve log data from the unit. The format of the command is as follows:

GL,logfilename,datetime,recordID,numbytes

- The logfilename can be used to return log entries of specific types. The available types are data, events, and all.
- The datetime value must be in the following format: MM/DD/YYYY HH:MM:SS.
- The numbytes value refers to the number of data bytes from the log entry to include in the response, not the number of bytes to store in the return packet. Since the client station or transport medium may be limited in the number of bytes that can be handled in a single packet, the numbytes value should be sized small enough to allow for header and CRC information, as well as translation to ASCII if that is the selected protocol (the ASCII protocol uses two bytes to represent every data byte). If numbytes is *, the all log records found will be returned. Regardless of the requested numbytes, only complete log records are returned.

The format of the reply is as follows:

GLR,status,recordID,numbytes,data[numbytes,data]

The value of status can be any of the following values:

Value	Description
0	Ok.
1	File not found.
6	Record not found.
7	Command format error

The datetime value in the response message is the datetime of the returned record and, therefore, may be different from the datetime in the GetLog command statement.

The data to the end of the file can be read by leaving datetime at the desired starting point and incrementing recordID until the status indicates record not found. The [numbytes,data] represents an additional record of data if there is room in the message.

Example:

command: GL,data,02/07/2007 15:50:00,80,0

reply: GLR,0,0,38,02/07/2007,15:51:00,VBAT,13.16,Volts,G
37,10/07/2003,15:51:10,A,10.89,5.2,-25.4
command: GL,data,02/07/2007 15:50:00,80,2
reply: GLR,0,2,37,02/07/2007,15:54:00,C,10.89,5.2,-25.4,0

The GLR response will contain as many log records as can fit into the response.

The numbytes value in the GLR response does not include the comma preceding the data, and refers to the number of data bytes from the log that are being returned, not the number of packet bytes used to store the response (which would be twice the data bytes when ASCII protocol is selected).

Appendix A – Specifications for the Bubbler

56-0133-XX SINGLE ORIFICE BUBBLER

Electrical

Power Required	8-16VDC, 4 amp/8amp for 50psi
Average Power	<8.3 mA @12V for a 3 second measurement every 15 minutes, no purge. <30 mA @12V for 120 second measurement every 5 minutes with 30 second purge every hour.
Pump current	on 4 Amp max, 2.5 Amp typical for 25psi/ 8A max for 50psi
Quiescent current	<1 mA
Outputs	SDI-12, RS232, RS485

Pneumatic

Pressure Range	0-25 PSI (0-57.5 ft or 17.5 m water) * 0-50 PSI (0-115 ft or 35 m water)*
Accuracy	0-20ft, ± 0.01 ft * 20-57.5 ft, $\pm 0.05\%$ reading * for 25psi unit 20-115 ft, $\pm 0.05\%$ reading * for 50psi unit
Resolution	0.0001 PSI
Purge Pressure	≥ 50 PSI max
Bubble Rate	Set by user (12 to 510 bubbler per minute)
Compressor Type	Piston

Mechanical

Enclosure	NEMA-4 Fiberglass (Compact model is NEMA-4X polycarbonate)
Dimensions	10.5" x 14" x 7.5" (Compact model is 8.5" x 10.5" x 7")
Pressure Outlet	3/8" Tube fitting

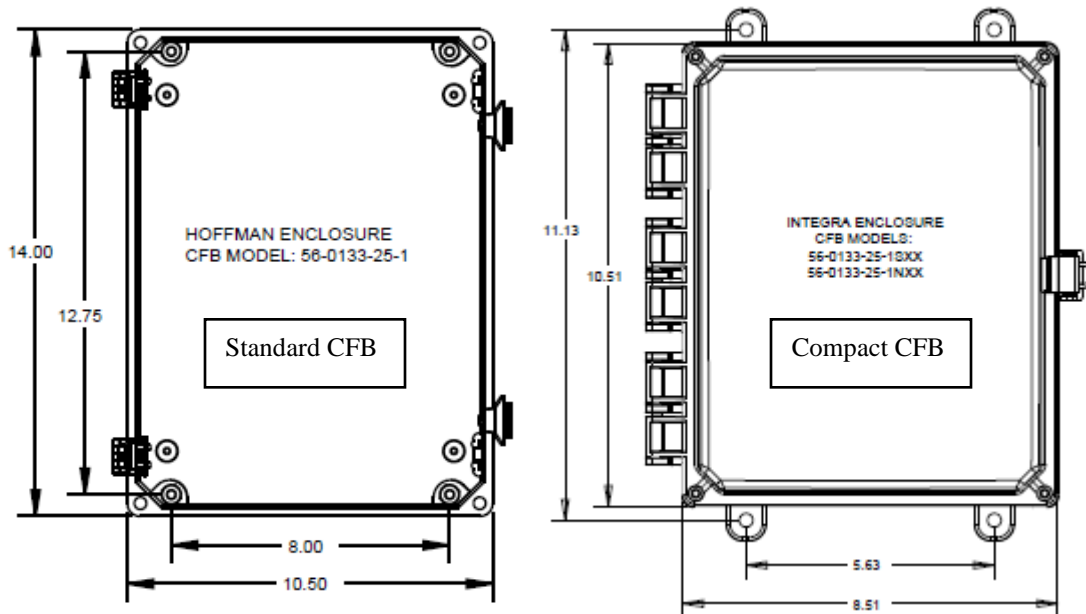

Environmental

Temperature -25°C to +60°C
optional -40°C to +60°C (P/N: BBL-ET)
Humidity 0-95% Non-condensing

56-0134-XX DUAL ORIFICE BUBBLER

Electrical

Power Required 8-16VDC
Average Power <15 mA @12V for a 3 second measurement every 15 minutes, no purge.
<30 mA @12V for 120 second measurement every 5 minutes with 30 second purge every day.
Pump on current 4 Amp max, 2.5 Amp typical for 25psi/ 8A max for 50psi
Quiescent current <1 mA
Outputs SDI-12, RS232, RS485

Pneumatic

Pressure Range 0-25 PSI (0-57.5 ft or 17.5 m water) *
0-50 PSI (0-115 ft or 35 m water)*
Accuracy 0-20ft, ± 0.01 ft *
20-57.5 ft, $\pm 0.05\%$ reading * for 25psi unit
20-115 ft, $\pm 0.05\%$ reading * for 50psi unit
Resolution 0.0001 PSI
Purge Pressure ≥ 50 PSI max
Bubble Rate Set by user, separate for each orifice line (12 to 510 bubbler per minute)
Compressor Piston
Type
Density 0.1% (excluding orifice spacing error) (-3-T model only)
Accuracy

Mechanical

Enclosure NEMA-4 Fiberglass
Dimensions 15" x 15" x 7.5" (40cm x 40cm x 20cm)
Weight 20.5lbs (9.3kg)
Pressure Outlet Dual 3/8" Tube fitting

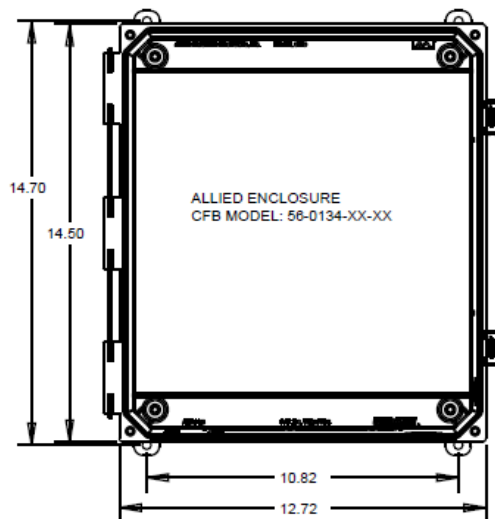

Environmental

Temperature -25°C to +60°C
optional -40°C to +60°C (order P/N: BBL-ET)
Humidity 0-95% Non-condensing

Suspended Sediment (-3-T model only)

Operation Range 0 to 1,000,000 mg/L
Accuracy ± 500 mg/L
(2ft separation) >10,000mg/L = 10.0% accuracy
>50,000mg/L = 2.0% accuracy
>100,000mg/L = 1.0% accuracy

WATER TEMPERATURE

Types Supported Platinum 385, Platinum 392, Thermistor, Custom
Sensor Operational Range -40°C to +60°C

The Following specifications only apply to specific Sutron sensors 5600-0100-100 & 5600-0030-1-050

Accuracy $\pm 0.1^\circ\text{C}$ (-5°C to +45°C)
Resolution 0.01°C

* references to ft based on USGS conversion factor of 2.3073 ft water per PSI (pure water @ 50deg C.)

Single Orifice Ordering Information

Part Number	Description
56-0133-25-1	Accubar Constant Flow Bubble (CFB) Gauge, 25 PSI max (17.5m/57ft)
56-0133-25-1C	Accubar CFB Gauge, 25 PSI max, 6mm orifice lines
56-0133-25-1-T	Accubar CFB Gauge, 25 PSI max, with water temperature capability
56-0133-25-1P	Accubar CFB Gauge, 25 PSI max, without enclosure
56-0133-25-1S	Compact CFB Gauge, 25 PSI max (17.5m/57ft)
56-0133-25-1SC	Compact CFB Gauge, 25 PSI max, 6mm orifice lines
56-0133-25-1ST	Compact CFB Gauge, 25 PSI max, with water temperature capability
56-0133-25-1SCT	Compact CFB Gauge, 25 PSI max, 6mm orifice line & water temperature capability
56-0133-25-1SP	Compact CFB Gauge, 25 PSI max, without enclosure
56-0133-50-1	Accubar CFB Gauge, 50 PSI max (35m/115ft)
56-0133-50-1C	Accubar CFB Gauge, 50 PSI max, 6mm orifice lines
56-0133-50-1-T	Accubar CFB Gauge, 50 PSI max, with water temperature capability
56-0133-50-1C-T	Accubar CFB Gauge, 50 PSI max, 6mm orifice lines & water temperature capability

Dual Orifice Ordering Information

Part Number	Description
56-0134-25-2	Accubar Constant Flow Bubble (CFB) Gauge, 25 PSI max (17.5m/57ft)
56-0134-25-2C	Accubar CFB Gauge, 25 PSI max, 6mm orifice lines
56-0134-25-2-T	Accubar CFB Gauge, 25 PSI max, with water temperature capability
56-0134-25-2C-T	Accubar CFB Gauge, 25 PSI max, 6mm orifice lines & water temperature capability
56-0134-25-3-T	Accubar Constant Flow, Dual Orifice Bubbler Gauge/Recorder with one Accubar water level sensor and one Accubar water density sensor. Includes water temperature capability and suspended sediment measurements.
56-0134-50-2	Accubar CFB Gauge, 50 PSI max (35m/115ft)
56-0134-50-2C	Accubar CFB Gauge, 50 PSI max, 6mm orifice lines
56-0134-50-2-T	Accubar CFB Gauge, 50 PSI max, with water temperature capability
56-0134-50-2C-T	Accubar CFB Gauge, 50 PSI max, 6mm orifice lines & water temperature capability

Accessories Ordering Information

Part Number	Description
5600-0100-100	Platinum 385 Water Temperature Sensor w/100 ft. cable
5600-0030-1-050	Thermistor Water Temperature Sensor with 50ft cable
2911-1279-1	Replacement Desiccant, full Canister
6661-1314-1	Orifice Termination Bubbler Termination fits on a 2" rigid pipe
2911-1183	Polyurethane, Black Orifice Tubing - 3/8" OD tubing, order by the foot (up to 2000')
6661-1320-1	Desiccant Kit (includes tubing, adapter, clamps, full desiccant canister) Optional item for Compact CFB models.

Appendix B– Sutron Customer Service Policy

CUSTOMER SERVICE POLICY

Dear Customer:

Thank you for making the important decision to purchase Sutron equipment. All Sutron equipment is manufactured and tested to the highest quality standards as set by Sutron's Quality Assurance Department. Our Customer Service Representatives have years of experience with equipment, systems, and services. They are electronic technicians with field and applications experience, not just with a technical background.

Customer Phone Support

Customer Service Representatives routinely handle a wide variety of questions every day. If questions arise, please feel free to contact me or one of the Customer Service Representatives. We are available from 8:00 am to 5:00 pm Monday through Friday and will be happy to take your call.

We can answer most sensor and interface questions on the first call. If we cannot quickly answer a question on an interface, we will work with you until we find a solution.

Sometimes a problem is application related. Although we pride ourselves on handling 95% of application related questions over the phone, we maintain constant contact with our Integrated Systems Division and Engineering Division for additional assistance.

Introductory Training

Training is an important part of the Sutron Customer Service philosophy. The Sutron training policy is simple---If you buy Sutron equipment, you get Sutron training! Without the proper training, you cannot take advantage of the benefits and advantages that Sutron equipment provides. We often supply on-site introductory training at your facility for no charge. You provide the classroom, students, equipment, and coffee---we'll provide the instructor.

On-Site Visits

Of course not all problems can be fixed over the phone. Sometimes a customer needs an on-site technician to identify site related problems or troubleshoot a network. Sutron can provide these services at a reasonable cost. Call for details. If you would like to learn more about Sutron products email sales@sutron.com

Thanks again for your order,

Paul Delisi
Customer Service Manager
Sutron Corporation

Appendix C– Commercial Warranty

SUTRON MANUFACTURED EQUIPMENT

THE SUTRON CORPORATION WARRANTS that the equipment manufactured by its manufacturing division shall conform to applicable specifications and shall remain free from defects in workmanship and material for a period ending two years from the date of shipment from Sutron's plant.

Sutron's obligation under this Warranty shall be limited to repair at the factory (21300 Ridgetop Circle, Sterling, VA 20166), or at its option, replacement of defective product. In no event shall Sutron be responsible for incidental or consequential damages, whether or not foreseeable or whether or not Sutron has knowledge of the possibility of such damages. This warranty shall not apply to products that have been damaged through negligence, accident, misuse, or acts of nature such as floods, fires, earthquakes, lightning strikes, etc.

Sutron's liability, whether in contract or in tort, arising out of warranties or representations, instructions or defects from any cause, shall be limited exclusively to repair or replacement parts under the aforesaid conditions.

Sutron requires the return of the defective electronic products or parts to the factory to establish claim under this warranty. The customer shall prepay transportation charges to the factory. Sutron shall pay transportation for the return of the repaired equipment to the customer when the validity of the damage claim has been established. Otherwise, Sutron will prepay shipment and bill the customer. All shipments shall be accomplished by best-way surface freight. Sutron shall in no event assume any responsibility for repairs or alterations made other than by Sutron. Any products repaired or replaced under this warranty will be warranted for the balance of the warranty period or for a period of 90 days from the repair shipment date, whichever is greater. Products repaired at cost will be warranted for 90 days from the date of shipment.

NON-SUTRON MANUFACTURED EQUIPMENT

The above Warranty applies only to products manufactured by Sutron. Equipment provided, but not manufactured by Sutron, is warranted and will be repaired to the extent of and according to the current terms and conditions of the respective equipment manufacturers.

REPAIR AND RETURN POLICY

Sutron maintains a repair department at the factory, 21300 Ridgetop Circle, Sterling, VA 20166. Turn around time normally ranges from 10-30 days after Sutron receives equipment for repair. **Call Customer Service at (703) 406-2800 for a Return Material Authorization (RMA) number.** Return the defective equipment to the factory, transportation charges paid.

EXTENDED WARRANTY AND ON-SITE MAINTENANCE

Extended warranty and on-site maintenance contracts are available. Price quotations may be obtained from Sutron customer service representatives.

?		Dual Density	16
? 37		Dual Expanded Range	16
		Dual Separate.....	16
A		E	
Accubar	17	Error codes.....	70
autozero.....	17	events.....	30
calibration	72	Expanded Range	16
ID	17	external sensor	32
replacement.....	73	F	
temperature	23	factory defaults	32
Auto Output	55	FastTrack	35
automeasure	24	front panel.....	36
interval	24	turning on/off.....	36
offset	24	Front panel	
AutoPurge	14	key functions.....	36
autozero.....	17	G	
averaging.....	25	GPS.....	76
B		Green LED.....	16
battery		H	
cut-off voltage.....	33	hardware error	37
measurement	33	Hardware Flow Control	53
battery voltage.....	33	I	
blockage		Installation	74
blocked flow	15	internal sensors	14
blocked pressure.....	15	L	
detection.....	15	last automeasured	25
BPM.....	13	leak test.....	15, 65
bubble rate	13	LED	16
bubble rate units.....	13	level units.....	23
C		local time offset	76
calibration	66	log	29
factory	72	daily values	30, 31
clock.....	33	download	30
Command line.....	53	download	54
Connections		events.....	30
DB9	11	format	30
Power	10	timestamp	30
RS232	11	LogBattery.....	33
SDI-12.....	10	logger	
continous operating mode		connecting to.....	32
contrast.....	36	Satlink.....	32
D		M	
DB9 Connector	11	Measurement Name	22
defaults.....	32	menu tree	38
deltaP	35	missing data	14
Density Temp.....	29	Modbus	79
desiccant	72	modem	60
display		Raven.....	61
turning on/off	36		
download log.....	30		
DQAP	25		

Modem		
Xpert	61	
mounting	64	
N		
normal operating mode	24	
NTC Thermistor	28	
O		
operating modes	24	
orifice		
installation	64	
P		
Passive sensor mode	34	
password	34	
Platinum RTD	28	
Power Connections	10	
pressure	13	
Accubar	17	
blocked	15	
pump run time	14	
purge	14, 65	
duration	14	
pressure	14	
Q		
quality		
water level	18	
R		
reading old	14, 41	
Red LED	16	
restrictor pressure sensor	14	
right digits	23	
RS232 Connector	11	
RS232 Wakeup	53	
RTC	33	
S		
Satlink	32	
SCCM	13	
SD card	31	
automatic log backup	31	
Bubbler setup	31	
log download	31	
SDI-12		
connector	10	
Data Old	41	
operation	41	
reference	41	
validity	41	
sensors		
Accubar	17	
internal	14	
restrictor	14	
tank	14	
setting water level	22	
Setup	32	
capturing	60	
saving	60	
SD card	31	
setup defaults	32	
Single	16	
software upgrade	58	
Stage	22	
Suspended Sediment	29	
T		
tank pressure sensor	14	
temperature		
Accubar	<i>See</i>	
Temperature, Water	27	
Terminal Block	10	
Thermistor	28	
time	33	
tube		
installation	64	
U		
units		
bubble rate	13	
water level	23	
upgrade	74	
W		
water level	18	
command line	53	
measuring	18	
right digits	23	
SDI-12	42, 44	
setting	22	
units	23	
Water Temperature	27	