



Instruction Manual

SOLYS2 • Sun Tracker

SOLYS Gear Drive • Sun Tracker

General User Information

Dear customer, thank you for purchasing a Kipp & Zonen (an OTT HydroMet brand) instrument.

This SOLYS instruction manual is intended for customers who have purchased the SOLYS with some or all of the accessory items that can be used to enhance or expand its capabilities. It includes all the information necessary to install and operate the SOLYS for stand-alone operation.

Tip When information refers to both types the sun tracker is addressed as **SOLYS**, otherwise the specific names **SOLYS2** and **SOLYS Gear Drive** are used.

We understand that no instruction manual is perfect, so should you have any comments regarding this manual we will be pleased to receive them at:

OTT HydroMet B.V.

Delftechpark 36, 2628 XH Delft, - or
P.O. Box 507, 2600 AM Delft,
The Netherlands

+31 15 2755 210

solar-support@otthydromet.com

www.kippzonen.com

Warranty and liability

OTT HydroMet guarantees that the product delivered has been thoroughly tested to ensure that it meets its published specifications. The warranty included in the conditions of delivery is valid only if the product has been installed and used according to the instructions supplied by OTT HydroMet.

OTT HydroMet shall in no event be liable for incidental or consequential damages, including without limitation, lost profits, loss of income, loss of business opportunities, loss of use and other related exposures, however incurred, arising from the faulty and incorrect use of the product.

Modifications made by the user may affect the instrument performance, void the warranty, or affect the validity of the CE declaration or other approvals and compliances to applicable International Standards.

Copyright © 2023 OTT HydroMet B.V.

All rights are reserved. No part of this publication may be reproduced, stored in a retrieval system or transmitted, in any form or by any means, without authorisation by OTT HydroMet.

OTT HydroMet reserves the right to make changes to this manual, brochures, specifications and other product documentation without prior notice.

Manual document number: 0367910

Publication date: 16th June 2025

Declaration of Conformity

If necessary, you can download the current version of the Declaration of Conformity for the SOLYS Sun Tracker as pdf file from our website: "www.kippzonen.com/Download"!

Table of Contents

General User Information	3
Declaration of Conformity	4
0 Basic safety information	10
0.1 Symbols used in the instruction	10
0.2 Explanation of safety information used	10
0.3 Requirements for the technical qualifications of the installation personnel	10
0.4 Intended use	11
0.5 Note the following for safe and trouble-free operation	11
0.6 Instruction and warning signs attached to the SOLYS	12
1 Introduction	13
1.1 Product overview	13
1.2 Key parts of the SOLYS	14
2 Installation	15
2.1 Transporting SOLYS	15
2.2 Tools required for SOLYS installation	15
2.2.1 Tools required for shading ball assembly / sun sensor	16
2.2.2 Site preparation	16
2.3 Considerations and minimum operating area	16
2.4 Creating a firm base to mount the SOLYS Tripod Floor Stand	18
2.5 Mounting the SOLYS on the SOLYS Tripod Floor Stand	21
2.6 Levelling the SOLYS	23
2.7 Connecting AC/DC power	24
2.7.1 Connecting AC/DC power cable	26
2.7.2 Environmental conditions	29
2.7.3 Using a solar panel to power the SOLYS	30
2.7.4 Enabling power / LED status	30
2.7.5 LED status	31
2.8 Alignment of the SOLYS	34
2.9 Secure the Tripod Floor Stand	35

3	Accessories	36
3.1	Mounting side mounting plate (for shading assembly or pyrliometer)	36
3.2	Mounting the pyrliometer	38
3.3	Side mounting plate dimensions	39
3.4	Side mounting plate + PMOD-WRC PMO 6 absolute cavity pyrliometer	40
3.5	Side mounting plate + Middleton SP02 Sun Photometer	41
3.6	Side mounting plate + Eppley (A)HF Absolute Cavity Pyrliometer	42
3.7	Side mounting plate + Eppley NIP second pyrliometer mount	43
3.8	Side mounting plate + PGS-100 Sun Photometer	44
3.9	Large side mounting plate	45
3.10	The height extention tube	47
3.11	Mounting the sun sensor	49
3.11.1	Alignment of the sun sensor	52
3.12	Shading ball assembly	54
3.13	Top mounting plate assembly	58
3.14	Mounting Kipp & Zonen radiometers without ventilation unit	59
3.15	Mounting UVS instruments	61
3.16	Mounting Kipp & Zonen radiometers with ventilation unit	63
3.17	Mounting Eppley radiometers with or without ventilation unit	65
3.18	Large top mounting plate dimensions	67
3.19	Shading ball rods assembly	69
3.20	Tilted pyranometer mounting kit targeting the PV market	72
3.21	Small top mounting plate for installing a single Kipp & Zonen radiometer	73
3.22	Cold cover	75
3.23	Sun shield	76
3.24	How to guide the cables	77
3.25	Partnumbers shading assembly	78
3.25.1	Screw kit shading assembly	78
3.25.2	Screw kit for pyrliometer mounting	78
4	Ethernet communication and configuration	79
4.1	Ethernet connection	79
4.2	Computer connection	86
4.2.1	SOLYSMonitor	86
4.2.2	Adding a SOLYS	87
4.2.3	Adding a SOLYS over RS-485	88
4.2.4	Adding a SOLYS to network	89
4.2.5	Tracking status	90
4.2.6	Instrument status	91

4.2.7	Configuration	92
4.2.8	Communication	93
4.3	Web interface	95
4.4	External commands	97
4.5	Serial interface	102
4.6	Interfacing with thrid party applications	103
4.6.1	Error codes	103
5	Maintenance	105
6	Specifications	107
6.1	SOLYS Gear Drive specifications	107
6.2	SOLYS2 specifications	110
6.3	Height specifications SOLYS including instruments	112
6.4	RS-485 connection	113
7	Software overview	115
7.1	Algorithm	115
8	Firmware	117
8.1	Firmware upgrade	117
9	Trouble shooting	121
9.1	Problem check-list	121
9.2	FAQ	122
Appendices		123
A	Serial communication protocol introduction	123
A.1	Firmware release	123
A.2	Instrument hardware configuration	123
B	The protocol layer	124
B.1	Communication parameters	124
B.1.1	Default communication parameters	124
B.1.2	Miscellaneous	124
B.2	Client server protocol	124

C	The application protocol	125
C.1	Command structure	125
C.2	Overview	127
C.2.1	Overview commands	127
C.2.2	Overview command: 'set' parameter	127
C.2.3	Overview command: 'show' parameter	127
C.2.4	Overview command: 'clear' parameter	128
C.2.5	Overview command: 'reset' parameter	128
D	Description of the commands	129
D.1	Instrument operational mode	129
D.1.1	Set instrument operational mode	129
D.1.2	Show instrument operational mode	129
D.1.3	Clear user account (and operational mode)	129
D.2	Hostname	130
D.2.1	Show hostname	130
D.3	Network configuration	130
D.3.1	Set IP address method	130
D.3.2	Show IP address method	131
D.3.3	Set IP address	131
D.3.4	Show IP address	132
D.3.5	Set IP netmask	132
D.3.6	Show IP netmask	133
D.3.7	Set IP gateway	133
D.3.8	Show IP gateway	134
D.3.9	Clear IP configuration	134
D.4	Serial interface configuration	134
D.4.1	Set serial interface baud rate	135
D.4.2	Show serial interface baud rate	135
D.4.3	Set serial interface parity	136
D.4.4	Show serial interface parity	136
D.4.5	Set serial interface number of data bits	137
D.4.6	Show serial interface number of data bits	137
D.4.7	Set serial interface number of stop bits	138
D.4.8	Show serial interface number of stopbits	138
D.4.9	Clear serial interface configuration	138
D.5	Miscellaneous commands	139
D.5.1	Clear suntracking configuration	139
D.5.2	Clear all configuration	139

D.6	Reset commands	140
D.6.1	Suntracking reset	140
D.6.2	Warm reset	140
D.6.3	Cold reset	140
E	Description of the messages	141
E.1	Message types	141
E.2	Status messages	141
E.2.1	Simple status message	141
E.2.2	Extended status message	142
E.2.3	Status code	142
E.2.4	Instrument status	144
E.2.5	Motor status	145

0 Basic safety information

0.1 Symbols used in the instruction

Tip Useful information for the user.

Note Information that prevents potential damage or malfunction on the SOLYS2 / SOLYS Gear Drive.

0.2 Explanation of safety information used

The safety information used in these instruction manual is classified according to the nature and severity of a particular hazard. The hazard levels defined are indicated by the following signal words (**WARNING/CAUTION**) and pictograms (**orange/yellow triangle**) in these instruction manual.

WARNING **Warning of a hazardous situation with a medium level of risk**



The safety information specifies the nature and source of the hazard. If you fail to carry out the specified actions, the hazardous situation can result in death or serious injuries.

- > Action to prevent the hazardous situation!
- > Action to prevent the hazardous situation!

CAUTION **Warning of a hazardous situation with a lower level of risk**



The safety information specifies the nature and source of the hazard. If you fail to carry out the specified actions, the hazardous situation can result in minor or moderately severe injuries.

- > Action to prevent the hazardous situation!
- > Action to prevent the hazardous situation!

0.3 Requirements for the technical qualifications of the installation personnel

Persons involved in the installation of the SOLYS must have specific expertise in these areas (related to the activity):

- electrical engineering
- precision mechanics instalation skills

Note 0.4 Intended use

The intended use of SOLYS two-axis sun tracker is to provide a positioning platform used to point **specialized meteorological instruments** at the sun's movement across the sky. No other devices or objects may be installed on the SOLYS Sun Tracker! Any use for other purposes is not permitted!

0.5 Note the following for safe and trouble-free operation

- Please read this Instruction Manual before using the SOLYS for the first time! Make yourself completely familiar with the installation and operation of the SOLYS! Keep this Instruction Manual for later reference!
- Only use the SOLYS as described in this Instruction Manual!
- Avoid heavy shaking and shocks during transport and operation! The SOLYS is equipped with highly sensitive mechanical components. Only use the original packing for transport! Only transport the device in an upright position!
- Only install the SOLYS as described in this Instruction Manual!
- Note all safety information given within the individual installation steps!
- Use the personal protective equipment (PPE) listed below during installation.
- Inform all persons present during the installation work of any hazards that may occur!
- Ensure that the maximum permissible payload of the device must not be exceeded!
SOLYS2: 20 kg; SOLYS Gear Drive: 80 kg.
- Ensure the electrical, mechanical, and climatic specifications listed in the technical data are adhered to!
For further information see Chapter 6 "Specifications".
- Do not make any changes or retrofits to the SOLYS! If changes or modifications are made, any warranty will be void.
- Have a defective SOLYS checked and repaired only by the OTTHydroMet repair center! On no account carry out repairs yourself!
Only a qualified repair followed by a factory final test ensures the specified measurement accuracy.
- Properly dispose of the SOLYS after taking out of service. On no account put the SOLYS into the normal household waste.

0.6 Instruction and warning signs attached to the SOLYS



Read and observe operating instructions



General hazard warning



Electrical voltage warning



Rotating device warning



Protective conductor terminal



DC

DC, direct current input



AC

AC, alternating current input

1 Introduction

1.1 Product overview

The SOLYS two-axis sun tracker is an all-weather positioning platform used to point specialized instruments at the sun's movement across the sky. It is fully automatic and does not require a computer or software for installation or operation. The SOLYS does provide status information to monitor proper operation. SOLYSMonitor, a software program to monitor and log this information is provided with the sun tracker.

The integrated GPS receiver automatically configures location and time data. Multi-colour LEDs indicate the operating status and an Ethernet port allows for software upgrades. The high-efficiency belt drive system requires no maintenance.

The SOLYS has a tough and distinctive cast aluminum housing and comes as standard with one side plate. Mountings for a Kipp & Zonen pyrhelimeter are included. A second side plate can be fitted for an additional pyrhelimeter. Small or larger top mounting plates are available for convenient mounting of one or up to three Kipp & Zonen radiometers. Two type of tripod stands are available with integrated levelling feet. The SOLYS Gear Drive comes standard with the Sun Sensor.

The shading assembly accessory includes the top mounting plate and allows the tracker to be configured as a complete solar monitoring station.

SOLYS does not suffer from internal clock drift because time is updated by the GPS receiver. A sun sensor is included as standard for active tracking where the stability of the support platform cannot be guaranteed.

SOLYS has been designed to provide reliable sun tracking for mid (SOLYS2 <25 kg) or high payload (SOLYS Gear Drive <80 kg). Its accuracy is excellent for both solar monitoring or meteorological applications where reliability and accurate tracking is required.

The built in power supply accepts both 24 V_{DC} and 100 to 240 V_{AC} and allows the DC Voltage to be used as a backup.

SOLYS is an all-weather instrument providing optimal performance even in the harshest climates (from equatorial to Polar region). The built in heater extends the operating temperature down to -50 °C (SOLYS Gear Drive) or -40°C (SOLYS 2) and operates from AC power only. A sun screen makes it possible to extend the upper temperature range from +55 °C to +60 °C (SOLYS Gear Drive). The SOLYS features high accuracy, resolution and repeatability under any condition.

1.2 Key parts of the SOLYS

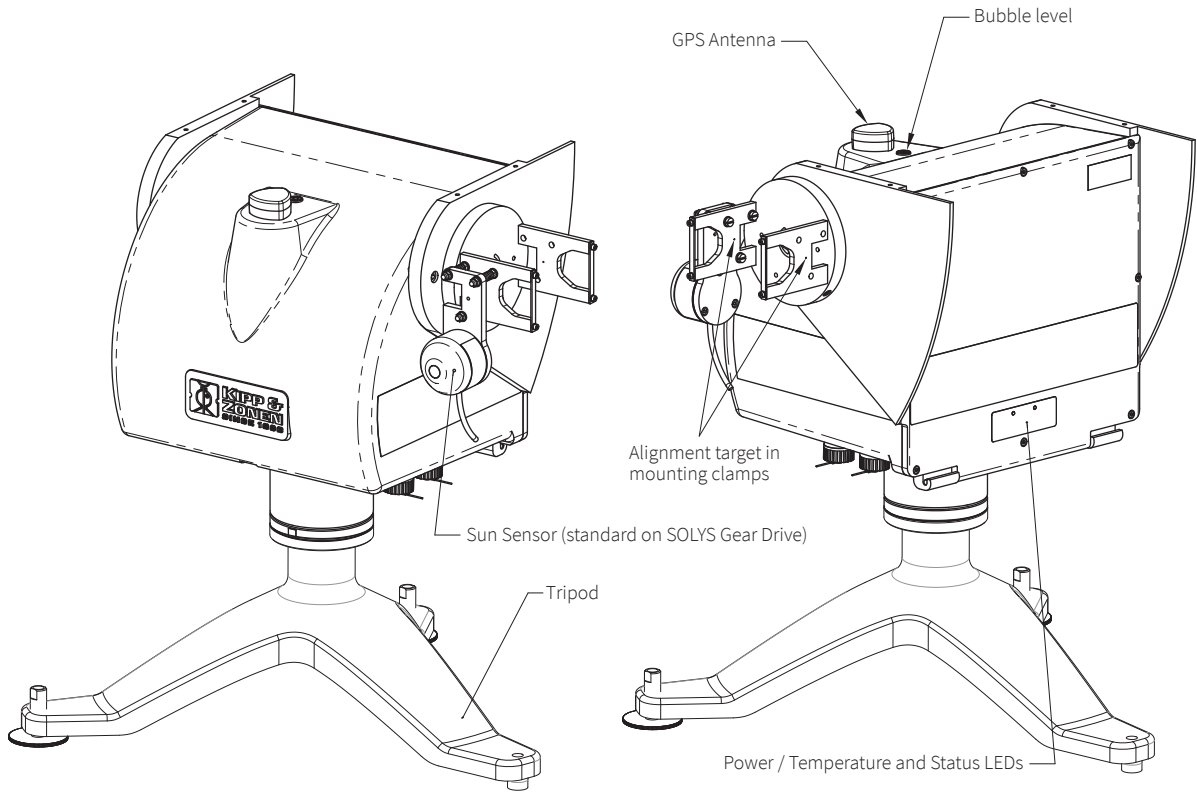

2 Installation

The following sections provide information on the installation of the SOLYS. The installation will be explained step by step in this chapter. A video of the SOLYS installation can be found on the product page of the SOLYS on our website.

Apart from the creation of the SOLYS Tripod Floor Stand support base and the assembling of the accessories and instruments, the levelling and the fine adjustment is only a matter of minutes. However a clear sun is required to do this adjustment. It is important that these steps are carried out in the right order.

Note If the Solys is rotated by hand during installation, the internal motors work as generators and produce unwanted electrical voltages. This could damage the motor drivers. A electronical protection circuit is integrated to prevent this.

2.1 Transporting SOLYS

CAUTION **Risk of injury from falling device!**



The SOLYS2 has a dead weight of approx. 23 kg, the SOLYS Gear Drive of approx. 26 kg!

- > Always have two people transport the SOLYS.
 - > PPE: Wear safety shoes during transport !
-

- Avoid heavy shaking and shocks during transport and operation! The SOLYS is equipped with highly sensitive mechanical components.
- Only use the original packaging for transport!
- Only transport the SOLYS in an upright position!

2.2 Tools required for SOLYS installation

For installation on site the following materials are included with the SOLYS.

- Allen Wrench key type 6 (for M8 bolts for tripod)
- Allen Wrench key type 3
- Allen Wrench key type 2.5
- Screws M8 x 20 plus M8 washers

Required but not included:

- Screwdriver for connection of power cable to the connector
- Cable for power connection of the SOLYS
- Compass to find geographical East

2.2.1 Tools required for shading ball assembly / sun sensor

The tools required for mounting the shading ball assembly are included.

Required but not included: A ruler, to measure the position of the sun sensor.

2.2.2 Site preparation

A site must be prepared before installing a SOLYS sun tracker. The following points need to be checked.

The site where the SOLYS sun tracker is placed must be free of obstructions. In order to have a free 360 degree field of view for the SOLYS sensors (see also pyranometer instruction sheets for details).

Build a concrete or steel horizontal platform for mounting the SOLYS tripod. The SOLYS tripod dimensions are given in this manual. A solid stable base is essential for accurate tracking.

Provide power connection for the SOLYS (100 to 240 V_{AC} and/or 24 V_{DC}; nominal; external circuit breaker/fuse required). The SOLYS has power connectors included for both, DC and AC power supply (no cable supplied). Because the SOLYS is rotating the SOLYS user needs to purchase flexible cable. Cable specifications are given in this manual. If both 24 V_{DC} and 100 to 240 V_{AC} are supplied the SOLYS will use the AC power supply until this is cut off. The SOLYS will then switch to DC power supply without interruption.

If a meteorological mast is placed near the SOLYS, make sure the position is such that the location of the mast is between the SOLYS and the nearest pole (North- or South pole). In this way the mast will never block the direct radiation. A rule of thumb is that the distance between a mast with height 'h' and the SOLYS should be at least 10 times 'h'.

2.3 Considerations and minimum operating area

Note The SOLYS, complete with all accessories attached, requires a substantial amount of unobstructed area to operate properly. This should be kept in mind when deciding where and how the unit is going to be installed. Figure 2.1 shows the minimum operating area with respect to both the Azimuth and Zenith axis of a SOLYS sun tracker complete with all accessories, including SOLYS Tripod Floor Stand and Shading Ball Assembly.

Keep in mind that the angle of Azimuth (horizontal) rotation changes during the year. A SOLYS installed in the winter will rotate further during summer, so make sure no objects will block its movement. To test the SOLYS and to prevent blocking its movement a rotation lap is performed by the tracker at initial power up (270° to the left and 270° to the right starting from home position).

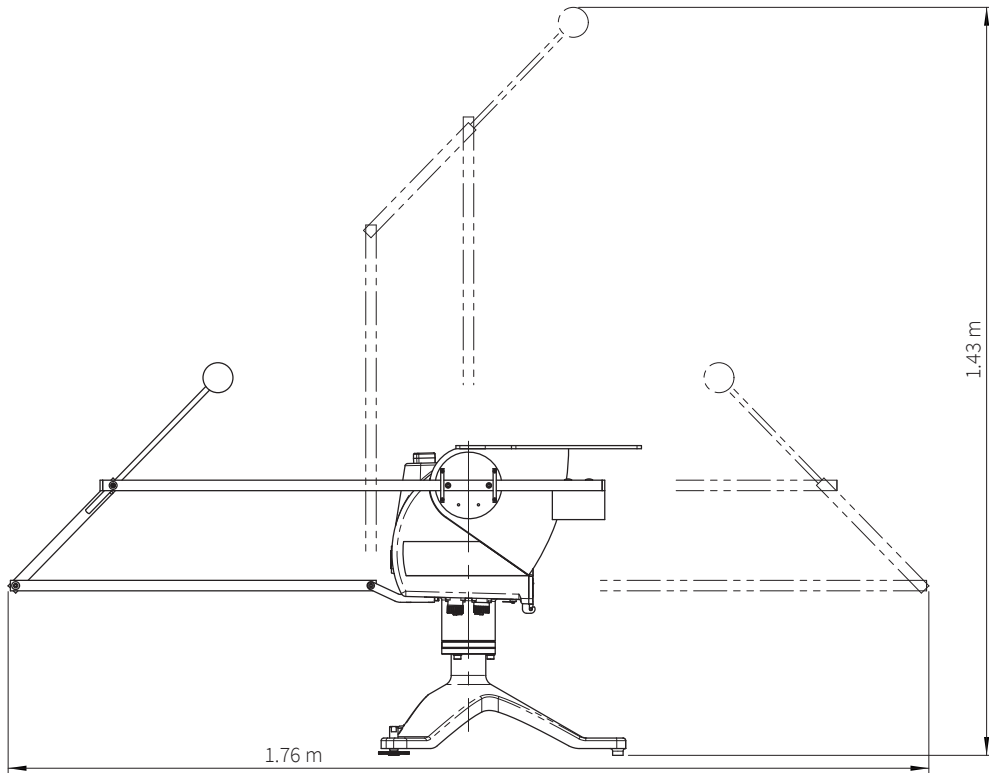

figure 2.1: Minimum Operating Area (with Shading Ball Assembly)

CAUTION**Risk of injury due to slowly rotating device!**

The SOLYS rotates slowly by approx. 540 degrees during commissioning and when the mains voltage is interrupted. During normal operation, the SOLYS rotates very slowly by a maximum of 540 degrees over the course of the day. In both cases, the SOLYS rotates around the vertical axis. In addition, the device rotates around the horizontal axis by a maximum of 110 degrees.

- > Keep a sufficient distance from the SOLYS, especially during commissioning and after an interruption in the mains voltage!
-

Note It is important to consider the following points before/during the installation of a SOLYS.

- Verify that all cabling is routed properly to prevent cables from catching on any fasteners supports, the SOLYS or instruments.
- Ensure that the surface on which the sun tracker will be mounted is reasonably level, but above all it is very important to create a very firm base for the feet of the SOLYS Tripod Floor Stand to sit upon.
- Make sure that the site will be free from any obstructions within the operating circle and that there is a clear view to the horizon in all directions.
- Make sure that the SOLYS and accessories will be accessible for maintenance purposes.
- Make sure that the SOLYS is located in such a way that shadows will not be cast onto the radiometers at any time.
- Ensure that before operation of the SOLYS the Sun Sensor cable and other mounted instrument cabling will not catch on any fasteners or supports. During the initial power up a rotation lap will be performed to check for blockage or cables which are too short.
- See section 3.24 for cable routing to allow free rotation all year.

2.4 Creating a firm base to mount the SOLYS Tripod Floor Stand

Figure 2.2 shows the necessary information to mount the SOLYS to a firm base. The tripod feet have 11 mm mounting holes to fix the SOLYS to this base.

Note The SOLYS Tripod Floor Stand has a Kipp & Zonen logo. This logo needs to be pointed to the East.

Note Mount options and instruments before final levelling and alignment of the SOLYS. Then tighten the tripod feet to the firm base.

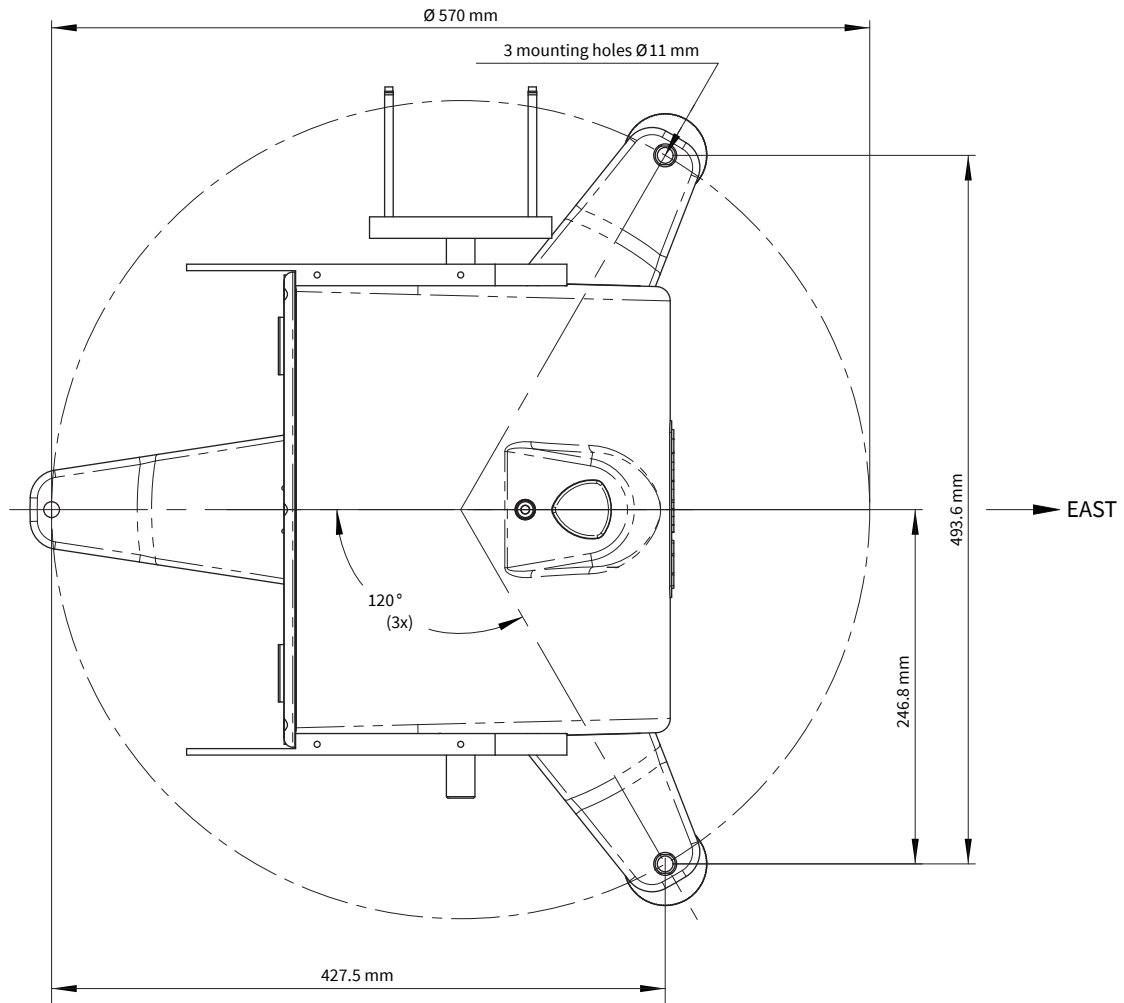

Figure 2.2: SOLYS Tripod Floor Stand footprint

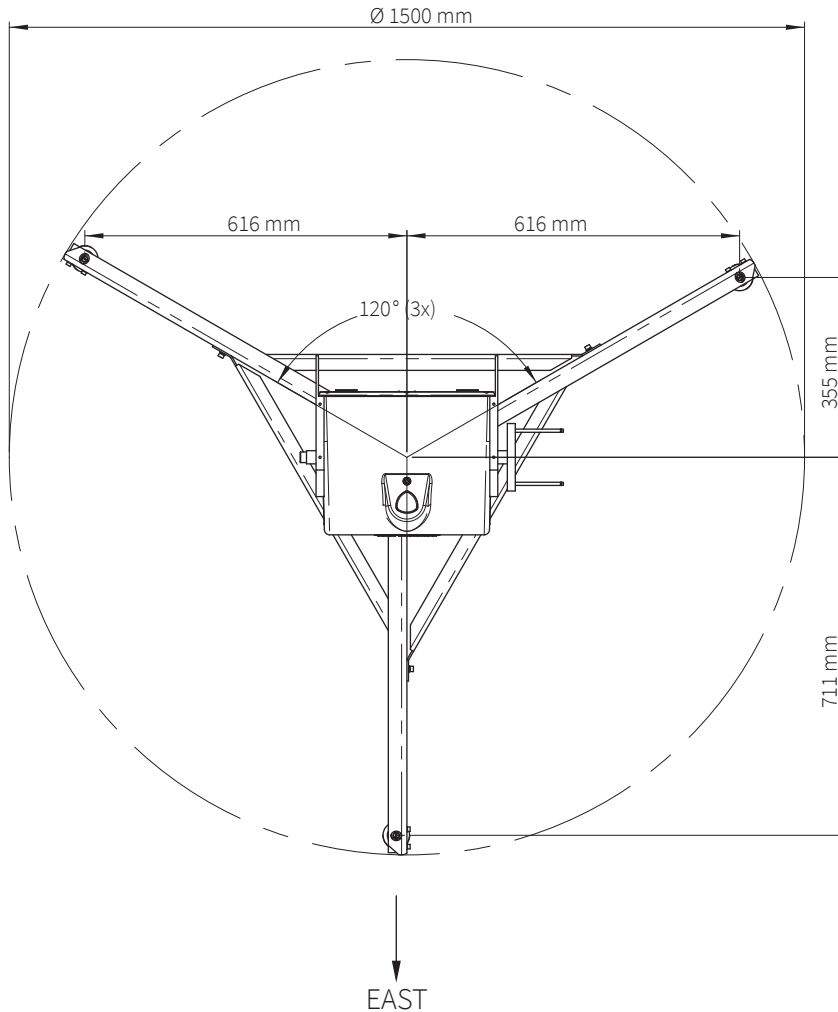

Figure 2.3: Heavy Duty Tripod Floor Stand footprint and orientation

Note For the Heavy Duty Tripod Floor Stand one of the 3 legs needs to point East

Note It is required to perform the levelling and alignment during installation of the SOLYS, options and instruments first, before actually tighten the tripod feet to the firm base.

2.5 Mounting the SOLYS on the SOLYS Tripod Floor Stand

The SOLYS is supplied with a standard $\varnothing 102$ mm bottom flange, which has a 3-hole M8 mounting pattern to match the SOLYS Tripod Floor Stand with levelling feet. The tripod has 3 slots for mounting the 3 M8 bolts to the bottom flange. Both the E mark on the bottom flange and the Kipp & Zonen logo on the tripod must point to the East when mounting the SOLYS. Ideally the bolts should be in the middle of the slots when the tripod is mounted to the SOLYS. This allows fine tuning the position afterwards.

Note Turn in the M8 bolts by hand. **Do not fasten** these M8 bolts during this first part of the installation. After aligning (chapter 2.7) they should be fastened.

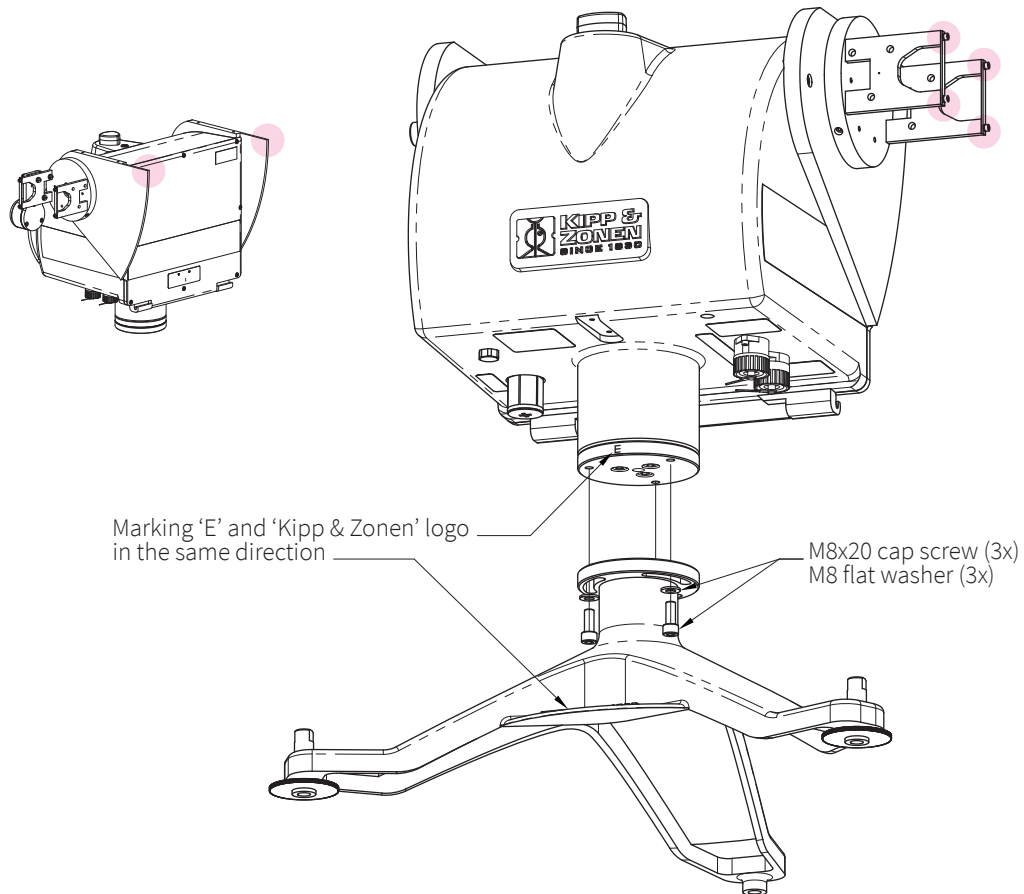

Figure 2.4: Mounting the SOLYS on the SOLYS Tripod Floor Stand

CAUTION Risk of injury from falling device!



The SOLYS2 has a dead weight of approx. 23 kg, the SOLYS Gear Drive of approx. 26 kg!

- > Always have two people transport the SOLYS.
 - > PPE: Wear safety shoes during installation!
-

CAUTION Risk of cuts from sharp-edged metal parts!



There are some sharp metal edges on the side plates of the SOLYS (highlighted red in the above drawing).

- > PPE: Wear safety gloves during installation !
-

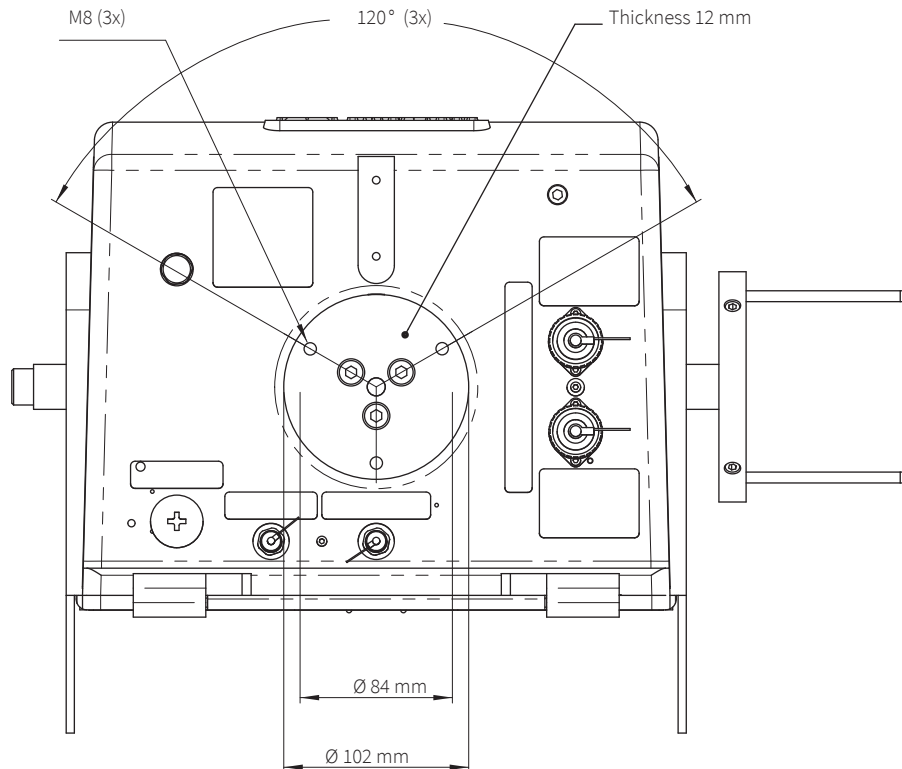

Figure 2.5: SOLYS bottom flange dimensions

Note When different mounting bolts are used they must not protrude through the bottom flange.

Tip When installed an initial Azimuth orientation due East with the help of a compass will do. When the SOLYS is powered later on, exact positioning can be performed when sun is available.

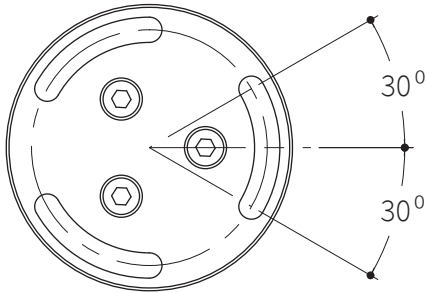
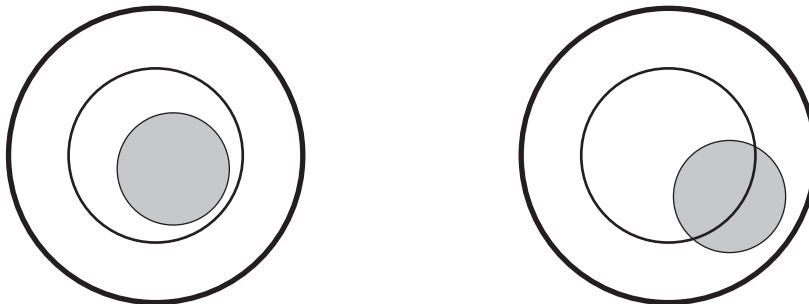

Figure 2.6: $\pm 30^\circ$ play on the tripod mounting before final adjustment

2.6 Levelling the SOLYS

Prior to activating the SOLYS, it must be levelled on its mounting surface. To help accomplish this task, the SOLYS is equipped with a high accuracy bubble on top of the housing. Adjust the levelling feet on the tripod stand to move the bubble into the centre of the level. The levelling feet can be easily adjusted using a 13 mm wrench. The accuracy of the SOLYS is within 0.1° when the bubble is within the circle.

During installation we recommend to keep the bubble inside the ring. However, if the bubble is half out of the ring the SOLYS is still within BSRN requirement 0.1° .



Note Rotating the SOLYS on its tripod is possible before the 3 M8 bolts are placed. The bubble level will move when the tracker is rotated 180 degrees. We recommend adjusting the levelling (feet) in such a way that the average bubble position is in the middle.

2.7 Connecting AC/DC power

WARNING Danger due to electrical voltage!



When connecting the supply voltage, there is a risk of touching live parts with electrical voltage that is dangerous to people!

- > Have all work (connecting, repairing, decommissioning) on the electrical equipment carried out only by appropriately trained specialists (e.g. electricians)!
 - > When assembling the "CA 3 LX" plug connector, ensure that there is no voltage on the electrical connection cables!
 - > Connect the SOLYS to protected earth via a PE wire.
-

Note Power supply via mains voltage (AC) and/or 24 V_{DC}

The SOLYS can be operated on either 100 to 240 V_{AC} or 24 V_{DC} (nominal). In case both AC and DC supplies are present and the AC voltage is within its operating range (100 to 240 V_{AC}) the SOLYS will use the AC supply. If the AC supply fails and DC supply is present the SOLYS will continue on DC power supply without interruption. Inside the solys are two fuses for the DC input line protection as well as a fuse for the heater protection (these fuses must not be replaced by the end user! Replacing by trained service staff only! Do not open the back plate!)

We recommend to protect the power supply of the SOLYS with an appropriately dimensioned external circuit breaker / fuse. For **mains voltage** supply: 4 A medium-acting external fuse

For **24 V_{DC}** supply: 2.5 A fast acting fuse

In both cases, the nominal voltage of the fuse must be selected to correspond to the level of the supply voltage!

Note Mains voltage power supply is required for an operating temperature between -40 °C and -20 °C

When operating on 24 V_{DC} the lower operating temperature of SOLYS is limited to -20 °C. When AC power is applied the standard built-in heater will be used. The use of the heater extends the lower operating temperature to -40 °C for the SOLYS2 and to -50 °C for the SOLYS Gear Drive. The internal heater automatically switches on below 5 °C. Starting up the SOLYS with a temperature below -20 °C it can take up to 30 minutes before the interior is -20 °C. When this minimum operating temperature has been reached the SOLYS will start operating.

Recommended power supply cable types/maximum cable lengths

	SOLYS2	SOLYS Gear Drive
Mains power supply (AC)		
- cable length	max. 30 m	
- cable type	standard low-voltage cable for mains power; three-wire (L + N + PE)	
- power consumption	@ 90 V _{AC} ≤ 1.34 A	≤ 1.94 A
	@ 264 V _{AC} ≤ 0.46 A	≤ 0.66 A
- wire cross-section	... 15 m 3 x 1.5 mm ² (@ 90 ... 264 V _{AC})	3 x 1.5 mm ² (@ 90 ... 264 V _{AC})
	15 ... 25 m 3 x 2.0 mm ² (@ 90 ... 264 V _{AC})	3 x 2.0 mm ² (@ 90 ... 264 V _{AC})
	25 ... 30 m 3 x 2.5 mm ² (@ 90 ... 264 V _{AC})	3 x 2.5 mm ² (@ 90 ... 264 V _{AC})
24 VDC power supply		
- cable length	max. 30 m	
- cable type	unshielded low-voltage cable, two-wire; additional (separate) wire for PE connection required if the device is supplied using 24 V _{DC} only	
- power consumption	@ 24 V _{DC} ≤ 0.83 A	≤ 1.04 A
- wire cross-section	... 15 m 2 x 0.75 mm ²	2 x 0.75 mm ²
	15 ... 25 m 2 x 1.5 mm ²	2 x 1.5 mm ²
	25 ... 30 m 2 x 2.5 mm ²	2 x 2.5 mm ²

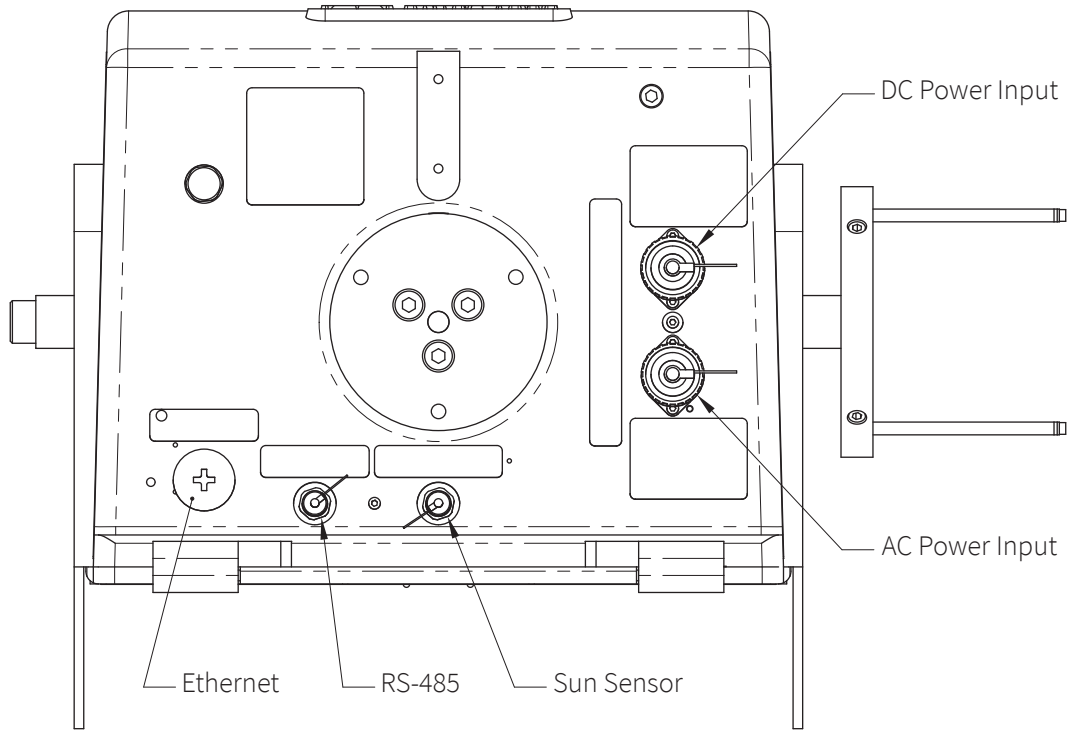

Figure 2.7: Connectors on the bottom of the SOLYS

2.7.1 Connecting AC/DC power cable

CAUTION Risk of injury due to slowly rotating device!



The SOLYS rotates slowly by approx. 540 degrees during commissioning and when the mains voltage is interrupted. During normal operation, the SOLYS rotates very slowly by a maximum of 540 degrees over the course of the day. In both cases, the SOLYS rotates around the vertical axis. In addition, the device rotates around the horizontal axis by a maximum of 110 degrees.

- > Keep a sufficient distance from the SOLYS, especially during commissioning and after an interruption in the mains voltage!

Please be aware that by powering up the SOLYS it will start the initialization procedure. During this procedure it will check the GPS signal, make a 540° rotation and stops in the home position for 60 seconds. It's advisable to connect the power cable while checking chapter 2.6.4.

The SOLYS is supplied with 2 waterproof power connectors for both AC and DC power. These connectors are in accordance with safety regulations for outdoor use. The voltage drop over the cable should not cause the supplied voltage to be out of specifications.

Both the AC and DC connectors are suitable for cable diameters between 6 and 12 mm. For 6 to 9 mm and 9 to 12 mm different sealing rings are used.

The AC connector is a female type Hirschmann CA 3 LD connector.

The DC connector is a male type Hirschmann CA 3 LS connector.

In figure 2.8 the pin numbers are indicated, where pin 3 will not be used.

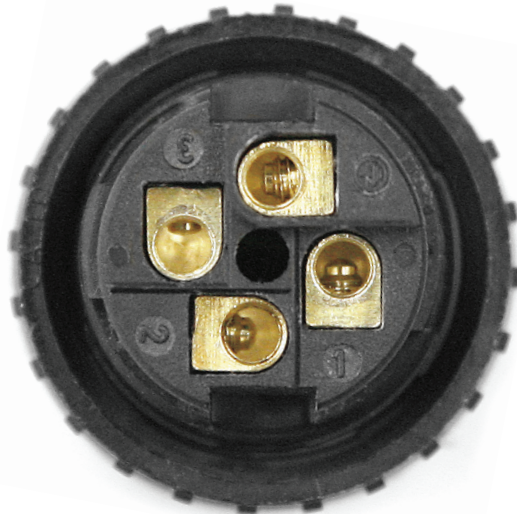

Figure 2.8: Pin numbering in male and female power connectors

The pin numbers and earth connection for the individual wires are visible when opening the connector.

for AC power supply (nom. 100 to 240 V):	for DC power supply (nominal 24 V):
Pin 1 = line; L	Pin 1 = +24 V _{dc}
Pin 2 = neutral; N	Pin 2 = GND
Pin 3 = not used	Pin 3 = not used
Earth pin = protective earth	Earth pin = protective earth

Drawings for both connectors and pin numbers including types of cable and number of strands are given in figure 2.9 and 2.10.

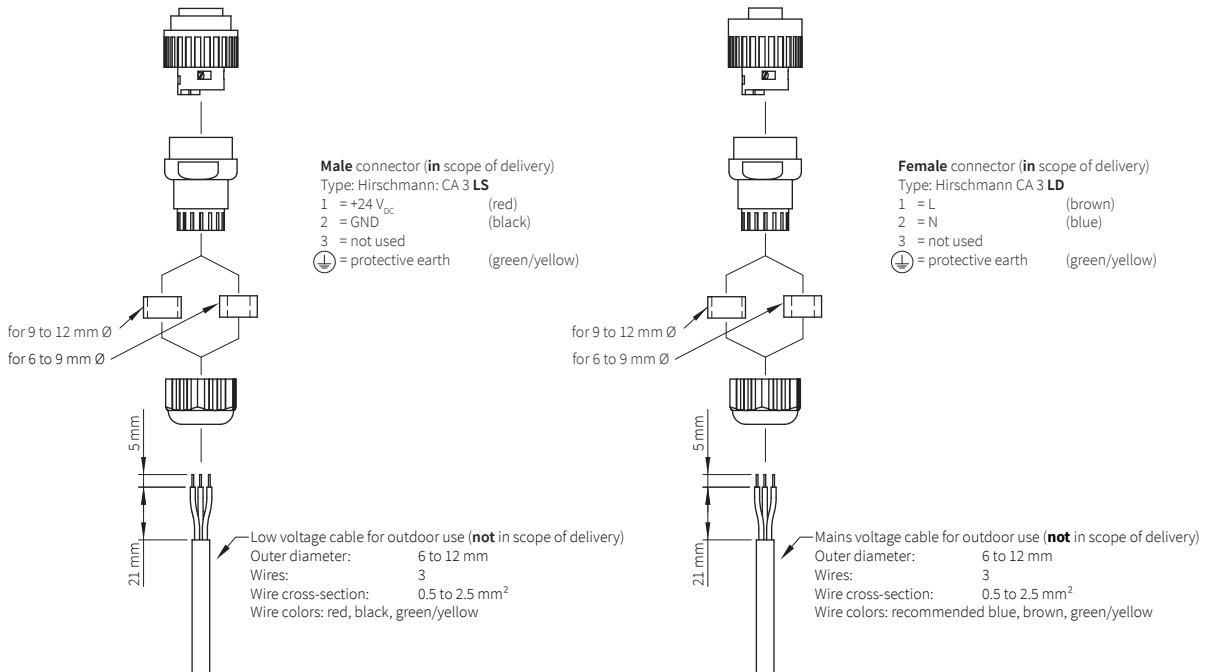

Figure 2.9: AC power cable connector (nominal 24 VDC)

Figure 2.10: DC power cable connector (nom. 100 to 240 VAC)

Please make sure the used cable is flexible enough to withstand the daily movement of the tracker.

2.7.2 Environmental conditions

Note With the SOLYS rear cover installed properly such that all 8 screws are secured, the SOLYS is environmentally protected to IP65, according EN 60529: 1991 + CI 1993. This qualifies the SOLYS to be used in weather conditions with all types of precipitation.

WARNING



Risk of burns due to potentially hot components!

Risk of crushing fingers and hands due to moving mechanical components!

Danger due to electrical voltage!

Inside the SOLYS there are potentially hot, live electrical components that are dangerous to people as well as moving mechanical components!

CAUTION



> Never open the back plate of the SOLYS!

Note External circuit breaker required!

A power on/off switch is not a part of the SOLYS; requirements for electrical equipment installed outdoors specify that:

- A power isolator (switch or circuit-breaker) must be included in the cable installation
- The isolator (switch or circuit-breaker) must be in close proximity to the equipment and within easy reach of the operator
- The isolator (switch or circuit-breaker) must be marked as the power disconnection device for the equipment used in weather conditions with all types of precipitation.
- The isolator (switch or circuit-breaker) must be dimensioned according to the following maximum total current consumption:

supplied by **mains voltage**: 2.0 A

supplied by **24 V_{dc}**: 1.4 A

2.7.3 Using a solar panel to power the SOLYS

If the system is operating on solar power only, please be aware of the reduced number of hours of sunlight during the winter. On cloudy days less than 50 % of the normal radiation comes in.

Rule of thumb is to use 10 times as much solar panel power.

How to determine what kind of solar panel is required; please add the power consumption of each additional instrument, computer, data logger or any other device together with the power consumption of the SOLYS and multiply this by 10.

Power consumption SOLYS Gear Drive on DC: 25W maximum, 20 W for SOLYS2, during sun cycle. After the sun cycle, the SOLYS will start its energy savings program and put itself to sleep mode. During this sleep mode the power consumption is 13 W.

20 minutes before the sun rises, the SOLYS will wake up, go to its home position and starts its active tracking mode with full power consumption.

Note If no other power is available, even a few days without sun should be covered by the back-up battery. Two 12 V backup batteries can be used in series for the SOLYS (24 V). For this application a DC fuse must be included in the cable between battery and SOLYS! Dimensioning the fuse: 2.5 A fast acting fuse.

2.7.4 Enabling power / LED status

After the SOLYS has been levelled and the power cable is assembled, the power can be switched on. The SOLYS will start its initializing mode. During this initializing mode, the SOLYS will check for any hardware errors, presence of the GPS signal, and in addition it will make an orientation lap to check for any blockades and to check if the cable length of the SOLYS (and attached instruments) is sufficient. This rotation will be performed each time the SOLYS is powered up.

During the orientation lap, the SOLYS will move 270° to the left starting at home position, and will move 270° to the right starting at home position.

Please make sure the cables have the correct length to perform this test. Cable routing is described in chapter 3.24.

2.7.5 LED status

The SOLYS is equipped with two multi-function LED's to inform the user about the operational status.

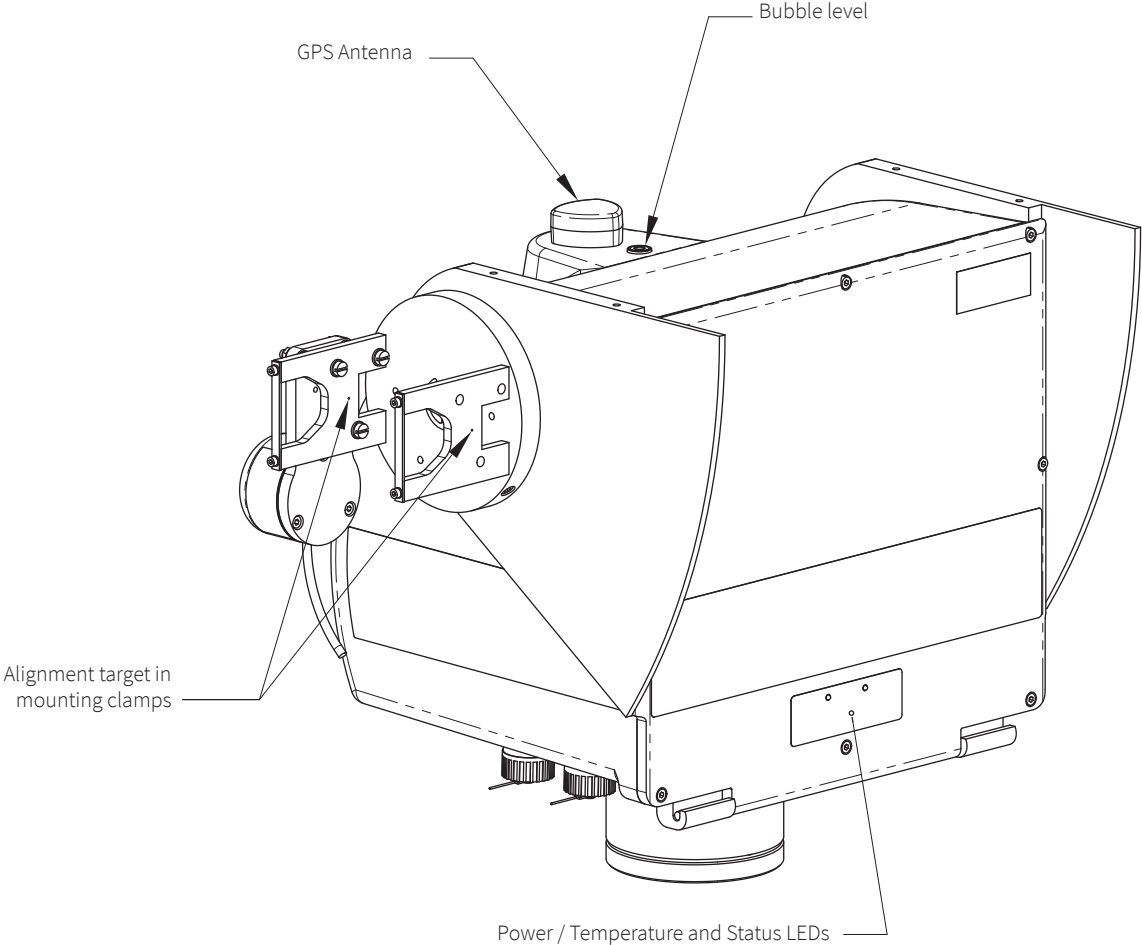

Figure 2.11: SOLYS LED status

The power / temperature LED shows if power is present (AC or DC) and the colour indicates the internal temperature of the SOLYS. Green is above -20 °C and red is below -20 °C. If this LED blinks it indicates an error of the heater fan. A 150 W heater for SOLYS Gear Drive and 100 W for SOLYS2 is built-in but only operates on AC power.

In cold conditions, when the power LED is red and the SOLYS is AC powered it can take a while before the internal heater has warmed the interior above -20 °C

The Status LED gives information about the tracker operation. RED indicates starting up or hardware errors, Orange shows the GPS information not present or lost. Green is the normal operating mode with GPS status. LED off and blinking means the SOLYS is in power save mode. The tables below show this information including combinations and blinking of the LED's.

SOLYS status LED	Red - blinking	Red - on	Orange - blinking	Orange - on	Green - blinking	Green - on	Off - blinking
Start-up	√						
Hardware error(s)		√					
Initialization complete	3x		3x		3x		
Tracking without GPS				√			
GPS position OK, waiting for time			√		√		
GPS information complete						√	
Radiation too low to use sun sensor					√		
Sun sensor not properly aligned	√				√		
Power save mode (night)	(√)		(√)		(√)		√

Normal start-up procedure after power on:

- Status LED blinking red during initialisation (time depends on tracker position)
- Status LED changing red / orange / green, three times to indicate initialisation complete (in this state the tracker is in home position)
- Status LED orange to indicate tracking without GPS (using previous GPS information)
- Status LED green / orange to indicate GPS position found but no time or not (yet) stable
- Status LED green to indicate GPS information complete (location, height, time and date)
- Status LED green / red indicate sun sensor more than 1.123° misaligned
- Status LED any colour combination blinking plus Off, SOLYS in power save mode

For example 'orange, green, off' means GPS position OK, waiting for time and SOLYS in power save mode (night time).

'Green, green, off' means GPS OK and SOLYS in power save mode.

The blinking is 1 s, so the last example shows 2 s green and 1 s off.

The misalignment of the sun sensor indication means it needs correction.

This can be done by disconnecting the sun sensor, realign the SOLYS (see chapter 2.7), connect the sun sensor again and check if alignment changes. If it changes than also re-align the sun sensor again (see chapter 3.11.1)

SOLYS power/temperature LED status	Red - blinking	Red - on	Green - blinking	Green - on
Temperature < -20 °C, fan OK, input voltage OK		√		
Temperature > -20 °C, fan OK, input voltage OK				√
Temperature < -20 °C, fan error, input voltage OK	√			
Temperature > -20 °C, fan error, input voltage OK			√	

Input voltage can be 24 V_{DC} or 100 to 240 V_{AC} (nominal), if both are present AC power will be used. When running on AC power and the internal temperature is below -20 °C the tracker will not operate until -20 °C is reached (indicated by power / temperature LED) when running on DC power alone the tracker will try to start even below -20 °C. When operating on DC power (heater not active) the interior will remain above -20 °C for a long time, even when environmental temperature gets lower. The internal dissipation extends therefore the temperature range below -20 °C.

Note Receiving GPS information can take up to 12 minutes. If all goes well, both the status- and power LED should be green

2.8 Alignment of the SOLYS

Note Before starting the alignment please verify the following issues:

- The 3x M8 bolts which hold the SOLYS Tripod Floor Stand to the actually sun tracker should be fastened by hand only
- The SOLYS has to be leveled (chapter 2.5)
- The SOLYS needs to be supplied with a power source (chapter 2.6)
- The status LED has to be green indicating it has received all GPS information (chapter 2.6.5)
- The power LED has to be green indicating a correct temperature, fan and input voltage (chapter 2.6.5)
- The sun sensor is not connected yet
- Sun with unobstructed sky ($\text{DNI} > 300 \text{ W/m}^2$) is required

When these requirements are met, the final adjustment can be made by rotating the SOLYS on its Tripod Floor Stand until the sun, falling through the first alignment target hole, makes a round spot of light around the second alignment target hole (see illustration 4.5). The vertical adjustment of the side mounting plate is a factory setting which should be OK. If the side mounting plates have been loosened or removed adjust the zenith position as well until the alignment target points at the sun and fasten the screws of the side mounting plates.

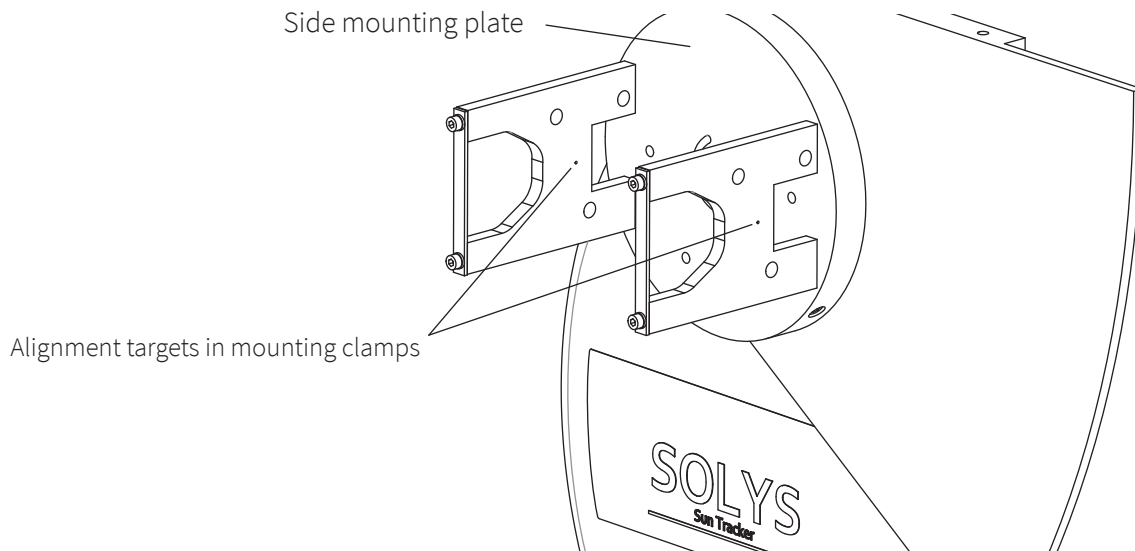

Figure 2.12: Alignment targets

Note Repeat this alignment after mounting the pyrhelimeter (chapter 3.2).

The pyrhelimeter also has two alignment targets holes which can be used for a second alignment. Because of the larger distance between the alignment holes, these are slightly more accurate than on the mounting clamps.

2.9 Secure the Tripod Floor Stand

After the SOLYS is levelled and aligned, it's time to fix the SOLYS Tripod Floor Stand feet to its firm base. Please perform a re-check of the levelling and alignment after the tripod feet have been attached to its base.

Tip After the SOLYS is levelled and properly secured recheck all radiometers for proper alignment and levelling.

3 Accessories

This chapter provides all the information on the accessory installation of all possible SOLYS accessories and instruments.

3.1 Mounting the side mounting plate (for shading assembly or pyrhelimeter)

The SOLYS is supplied as standard with one side mounting plate. This plate is factory installed in the correct position. No readjustment is needed.

A second side mounting plate is used in conjunction with the shading ball assembly or for mounting a second pyrhelimeter. The supplied plates can be customized to meet your specific configuration requirements. For alignment of a second mounting plate a clear sun is required to adjust the position on the axis. During normal operation (SOLYS turned on) the position of the side mounting plate can be fixated with the alignment target on the mounting clamps (or pyrhelimeter). The hole pattern of the side mounting plate is given in figures 3.1 and 3.3. If a second side mounting plate is used to mount the shading drive arm (without instrument mounting clamps) this drive arm should be aligned with the first one before fixating the screws on the axis. The SOLYS can handle payloads up to 80 kg including all accessories.

- Turn on the power of the SOLYS
- Pre-assemble the side mounting plate as shown in figure 3.1 and attach the side plate assembly to the Zenith shaft. Ensure that the plate is pushed up against the end of the Zenith shaft.
- Check the circular bubble level once more to verify that the SOLYS is still properly leveled
- Use the alignment target to position the side mounting plate to the sun. This requires that the SOLYS is running and a clear sun is present, or align the second shading arm with the first one (as described under shading ball assembly)
- Tighten the two M6 screws inside the side mounting plate to securely clamp it to the shaft (use wrench #3)

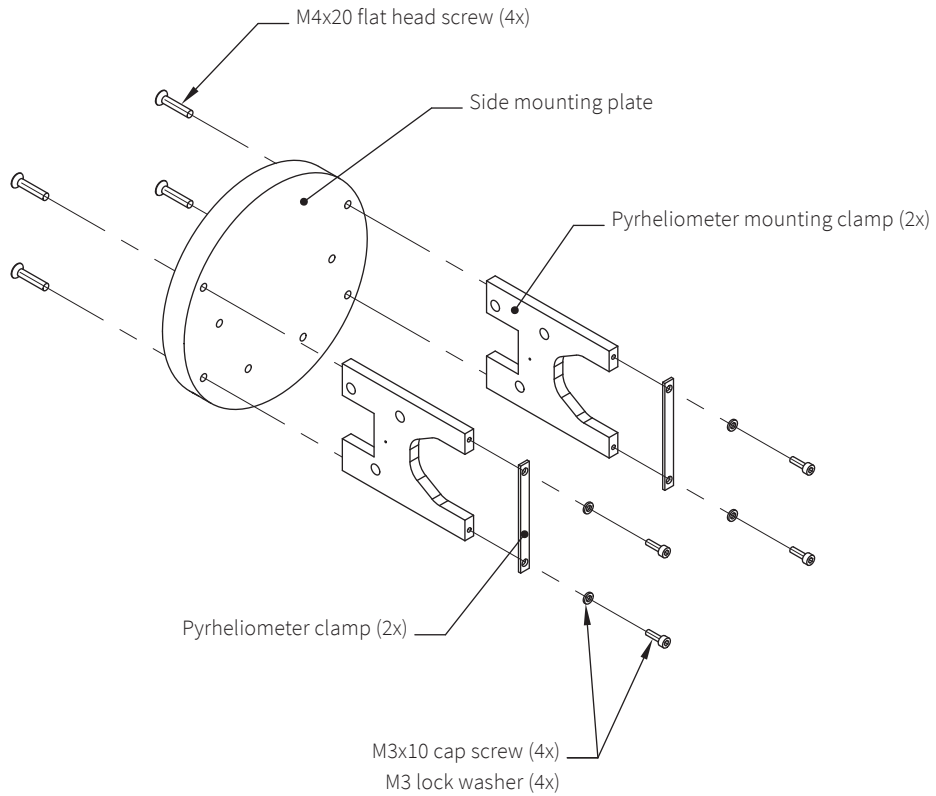

figure 3.1: Assembling a side mounting plate with pyrheliometer mounting kit

3.2 Mounting the pyrheliometer

The figure below shows how to install Kipp & Zonen pyrheliometers on the side mounting plate.

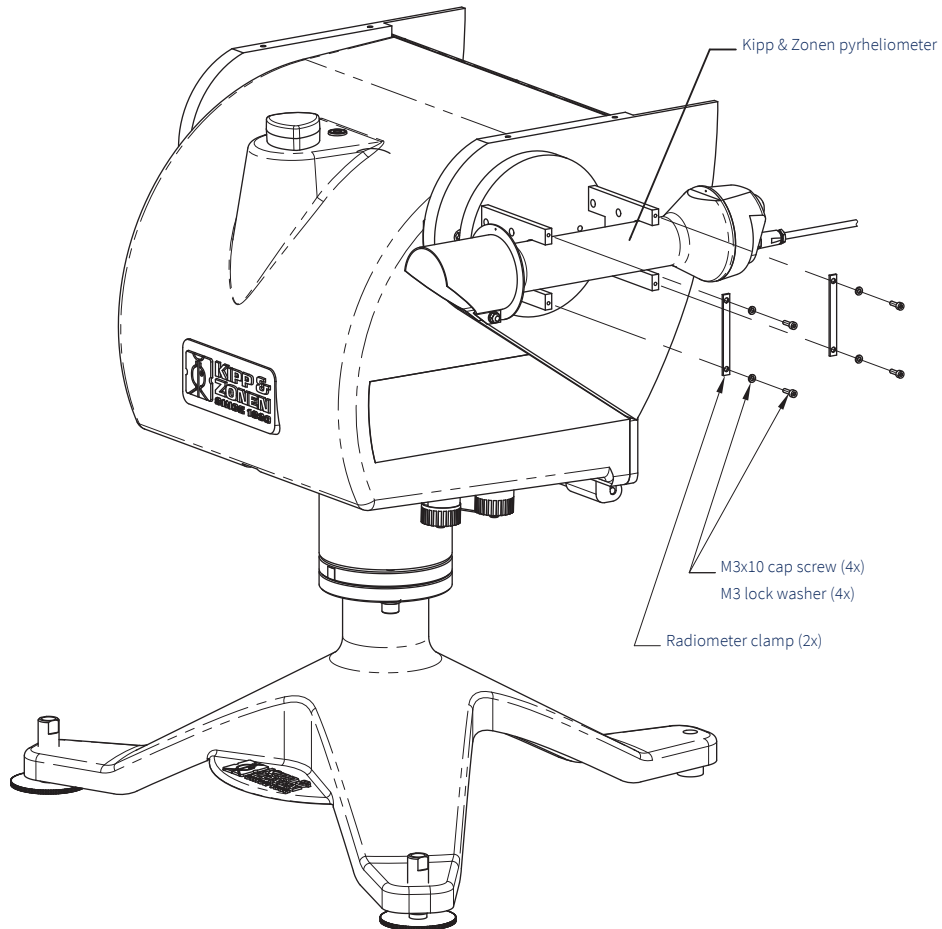

Figure 3.2: Pyrheliometer installation diagram

Note Recheck the alignment using the two alignment target holes on the pyrheliometer

The pyrheliometer has its own instruction sheet and manual for detailed information. In the instruction sheet you will find detailed information how to connect the pyrheliometer to a data logger.

3.4 Side mounting plate + PMOD-WRC PMO 6 absolute cavity pyrliometer

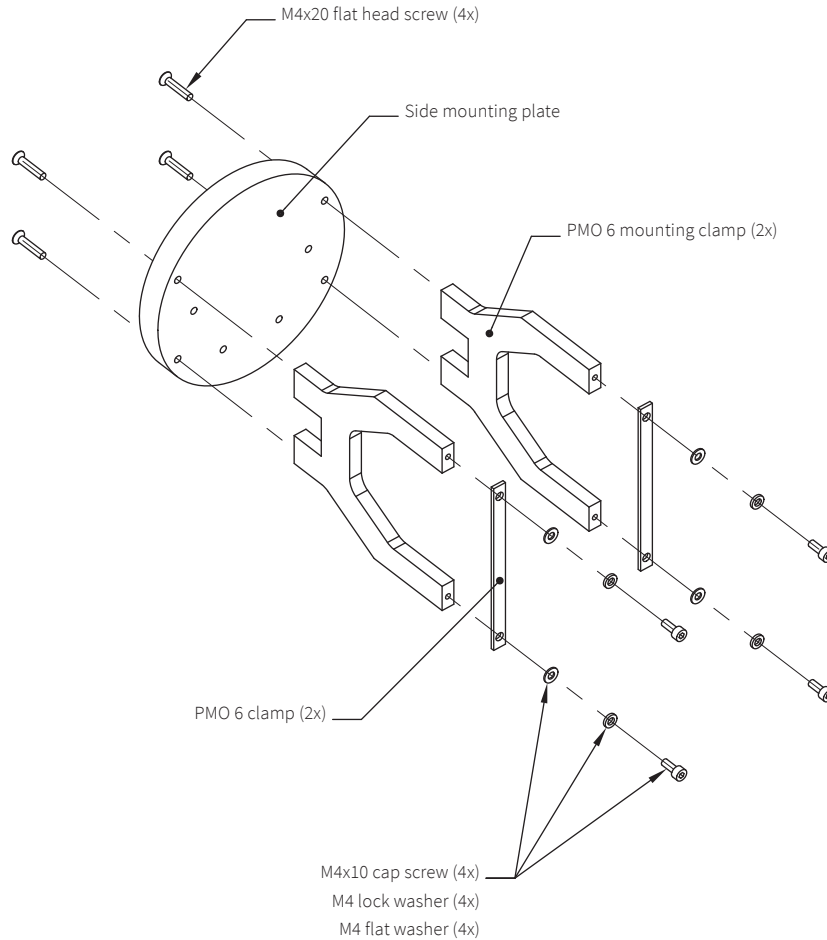

Figure 3.4: Installation of PMOD-WRC PMO6 Absolute cavity Pyrliometer on side mounting plate

Note The SOLYS has only one side mounting plate present as default.

When ordering a PMO 6 mounting kit, please check if you need an additional side mounting plate.

There is also a PMO 8 mounting kit available. Installation is carried out in the same way as the PMO 6 mounting kit showed above.

3.5 Side mounting plate + Middleton SPO2 Sun Photometer

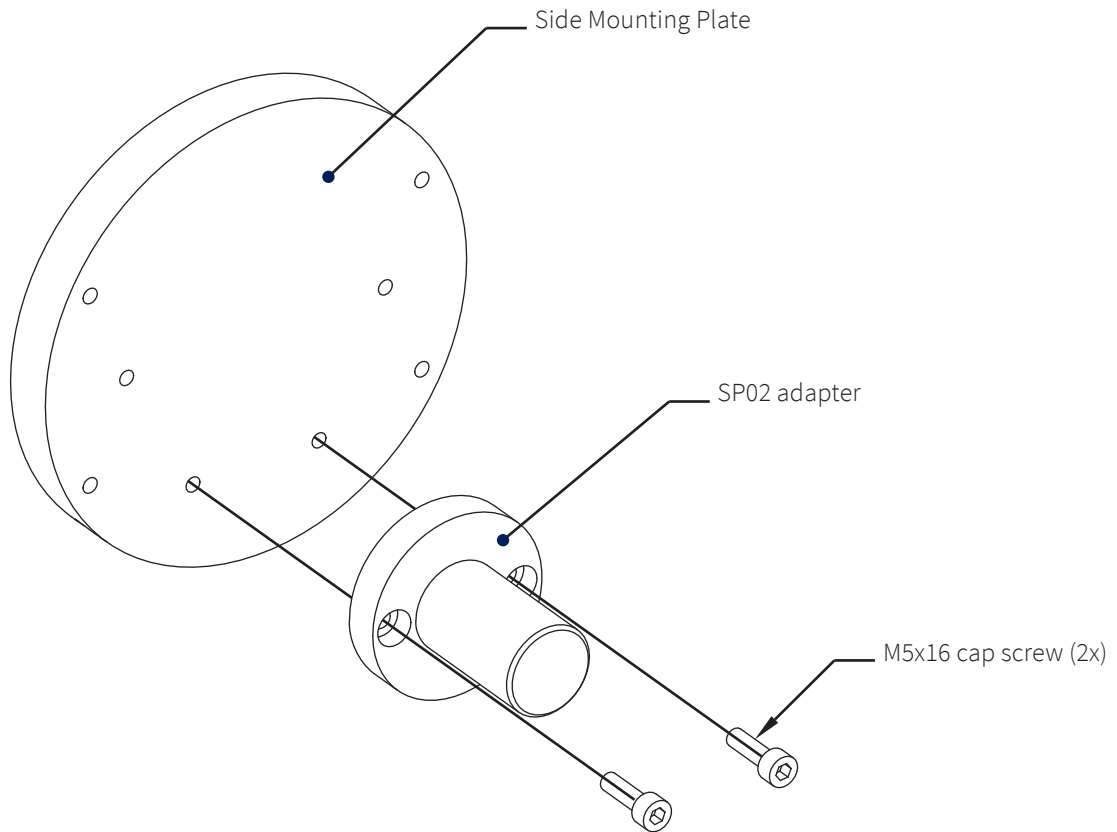

Figure 3.5: Installation of Middleton SPO2 sun photometer adapter on side mounting plate

Note The SOLYS has only one side mounting plate present as default. When ordering a SPO2 mounting kit, please check if you need an additional side mounting plate.

3.6 Side mounting plate + Eppley (A)HF Absolute Cavity Pyrheliometer

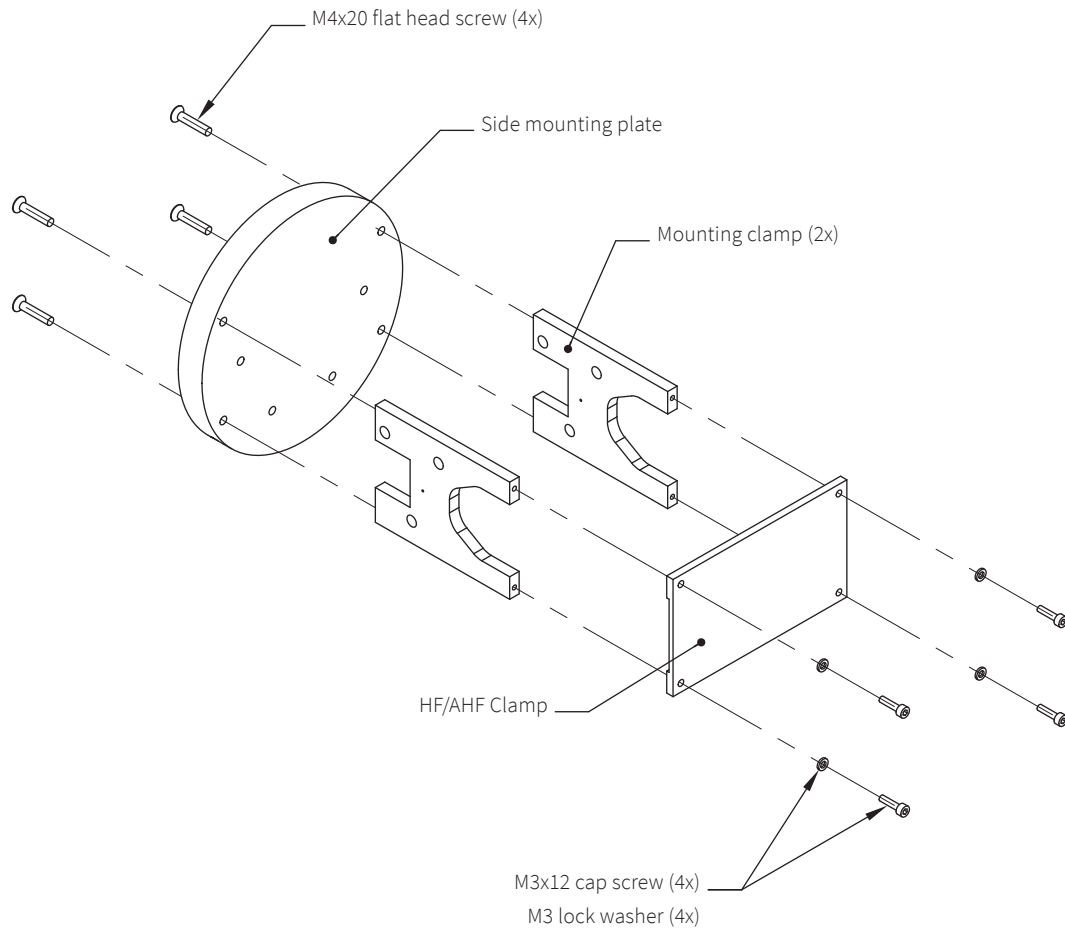

Figure 3.6: Installation of Eppley (A)HF absolute cavity pyrheliometer on side mounting plate

Note The SOLYS has only one side mounting plate present as default.
When ordering a HF/AHF mounting kit, please check if you need an additional side mounting plate.

3.7 Side mounting plate + Eppley NIP or second pyrliometer mount

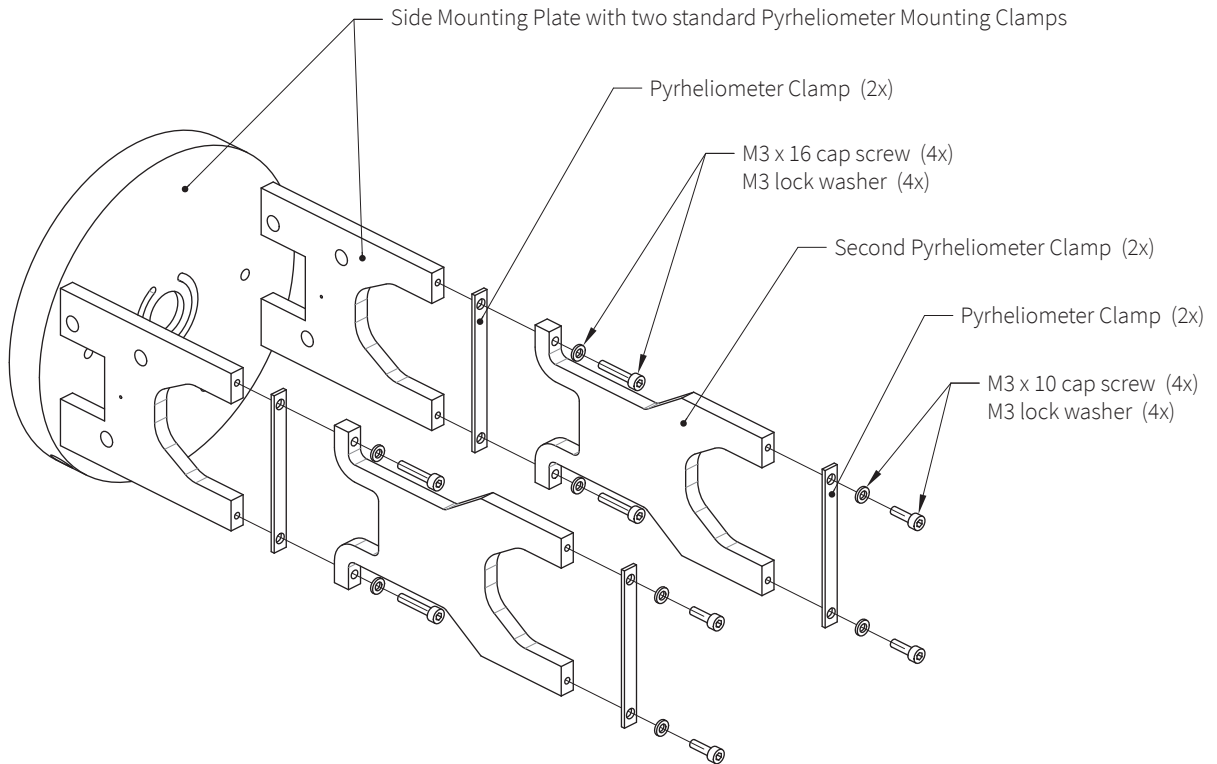

Figure 3.7: Installation of Eppley NIP or second pyrliometer on top of the existing mounting clamp

3.8 Side mounting plate + PGS-100 Sun Photometer

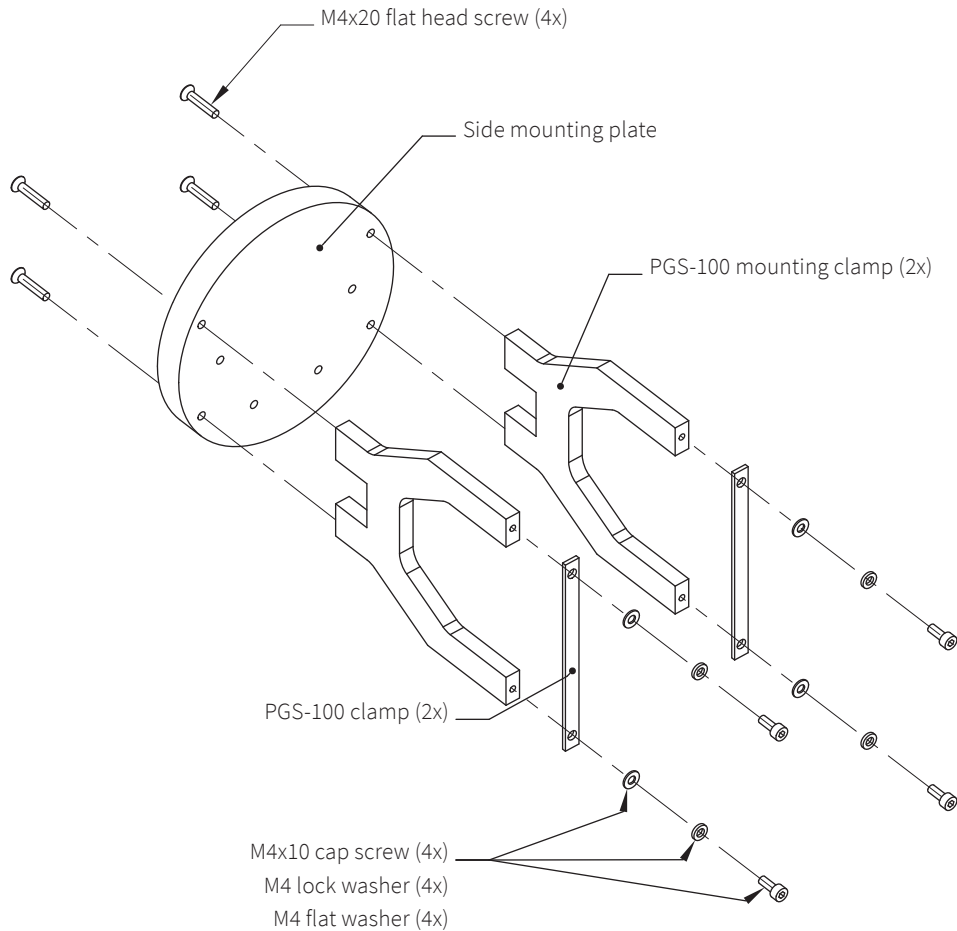

Figure 3.8: Installation of PGS-100 Sun Photometer on side mounting plate

Note The SOLYS has only one side mounting plate present as default.
When ordering a PGS-100 mounting kit, please check if you need an additional side mounting plate.

3.9 Large side mounting plate

The large side mounting plate allows for multiple options to one or both sides of the SOLYS Gear Drive.

The plate can be mounted in two positions:

- Preferred is using the centre hole (B), in this case the load is balanced
- If the top mounting plate is present the upper mounting hole (A) can be used

One large side mounting plate can be used for:

- 2 x Eppley AHF (required extra parts: 2 x 0367706 brackets)
- 2 x PMO-6 (required extra parts: 2 x 0367704 brackets)
- 2 x PMO-8 (required extra parts: 2 x 0367702 brackets)
- 2 x PGS-100 (required extra parts: 2 x 0367714 brackets)
- 3 x CHP1/SHP1 (required extra parts: 3 x 0367710 brackets)
- 6 x CHP1/SHP1 (required extra parts: 3 x 0367710 + 3x 0367717 brackets)

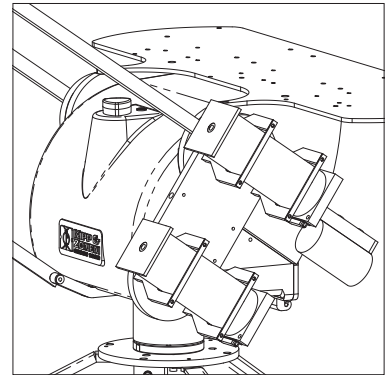
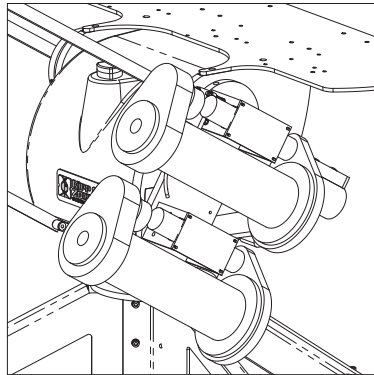
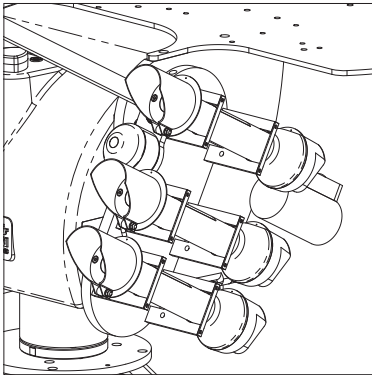

If the large side mounting plate is used on both sides, the above number of mountable sensors can be doubled, or combinations can be formed. The individual mounting brackets have to be ordered separately depending on the application.

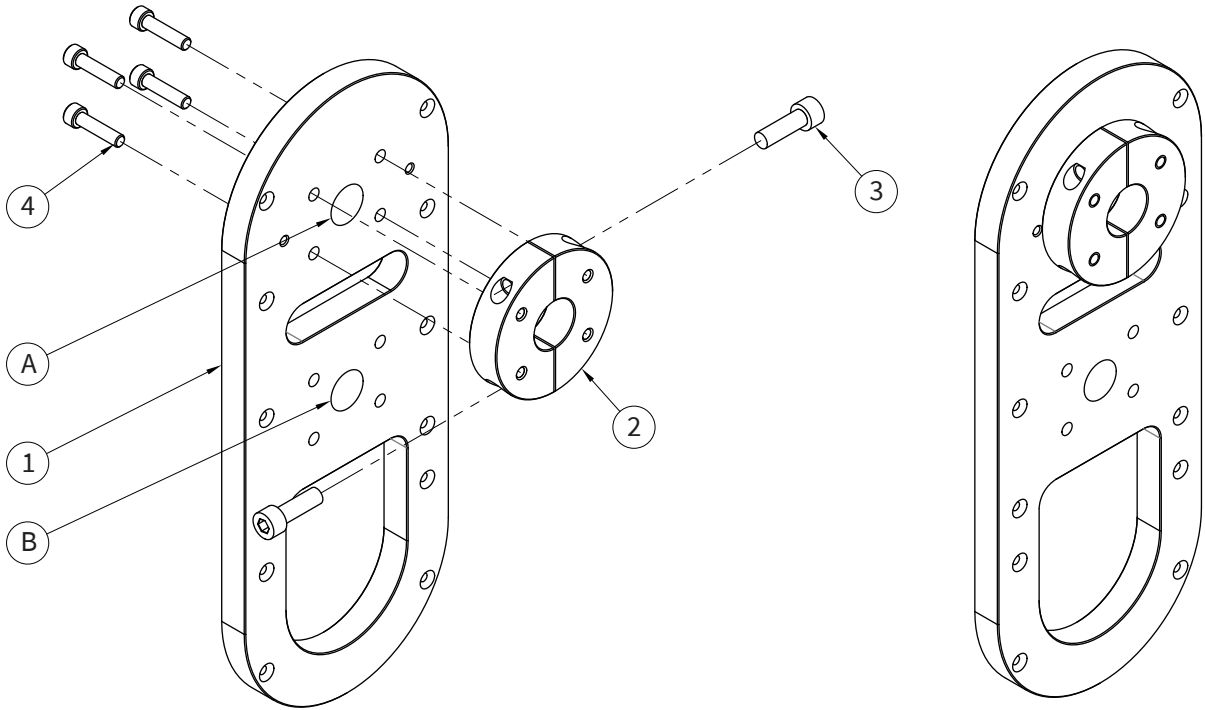

Figure 3.9: The large side mounting plate

Select mounting position A or B.

Mount the 2 halve rings (2) together with the 2 M8 bolts (3) and a 6 mm Allen key (hand tight)

Mount the ring (2) on the plate (1) with the 4 M6 bolts (4) and a 5 mm Allen key (hand tight)

Slide the ring and plate combination on the SOLYS axis, as far as possible (ring first)

Secure the ring on the axis by fastening the 2 M8 bolts (torque ~16 Nm)

Secure the plate on the ring by fastening the 4 M6 bolts (torque ~5 Nm)

3.10 The height extension tube

To raise the height of the sun tracker by 60 cm, it can be mounted on the Kipp & Zonen height extension tube. The tube can be mounted on the Heavy Duty Tripod Floor Stand. Mounting the height extension tube on the (small) Tripod Floor Stand is not possible. An adapter plate is included to mount the SOLYS on the tube.

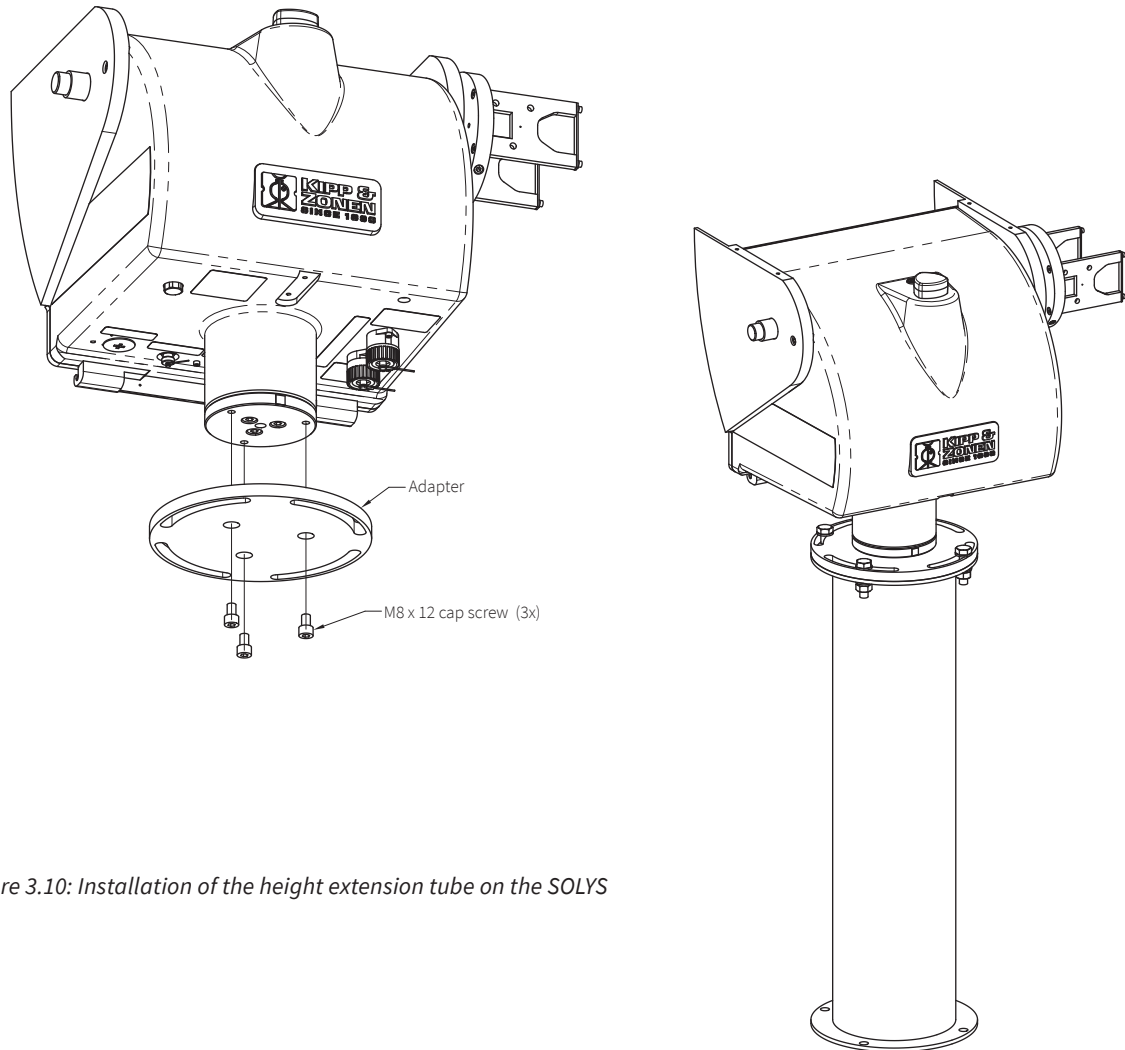

Figure 3.10: Installation of the height extension tube on the SOLYS

CAUTION**Risk of injury from falling device!**

The SOLYS2 has a dead weight of approx. 23 kg, the SOLYS Gear Drive of approx. 26 kg!

- > Always have two people install the SOLYS.
 - > Secure that the foundation of the tube is solid!
 - > When installing the SOLYS on a extension tube, secure the device against falling – e.g. using a mounting scaffold or an auxiliary rope!
 - > PPE: Wear safety shoes during installation!
-

3.11 Mounting the sun sensor

The standard sun sensor kit consists of a four quadrant photo diode sensor fitted within a weather resistant enclosure with SOLYS mounting hardware. The sun sensor is standard on the SOLYS Gear Drive. On the SOLYS2 it is optional.

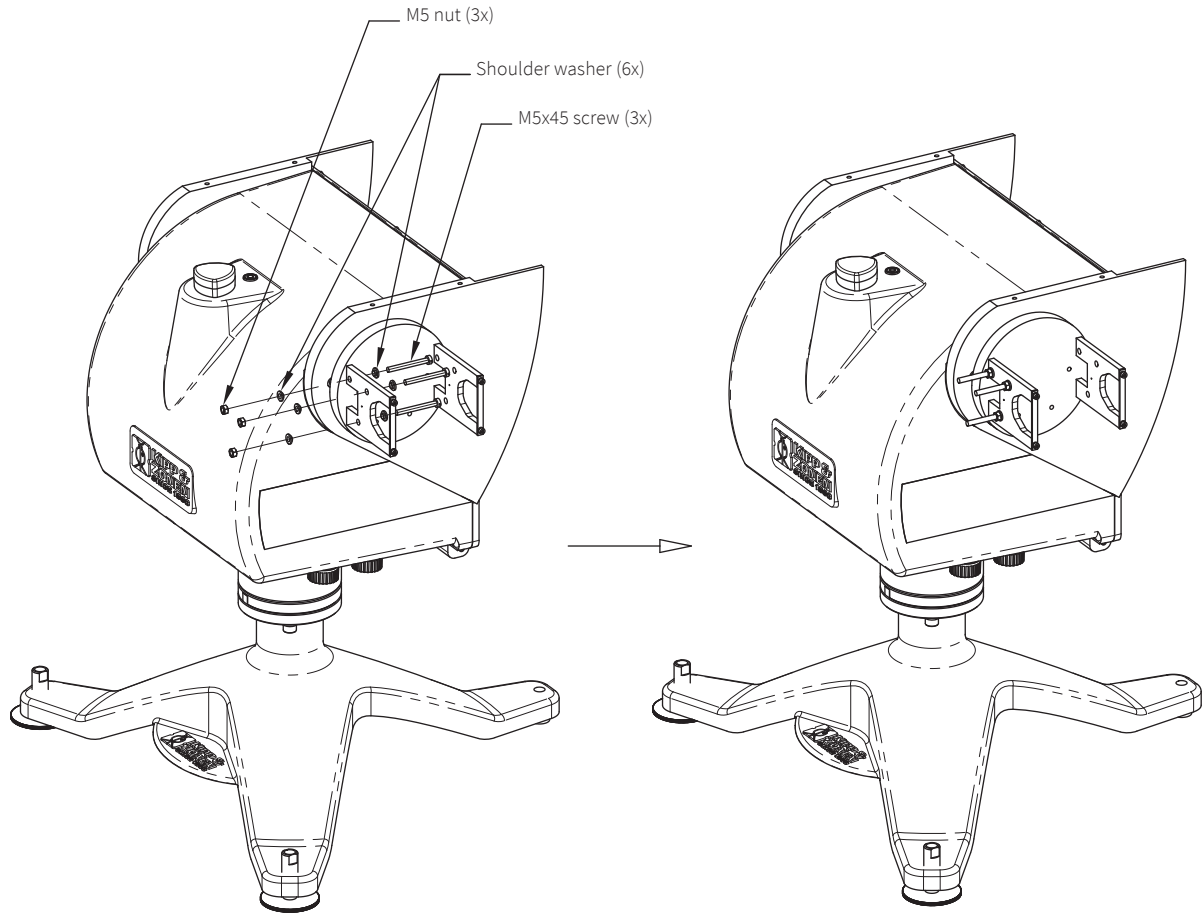

Figure 3.11: Preparing the mounting bracket for sun sensor mounting

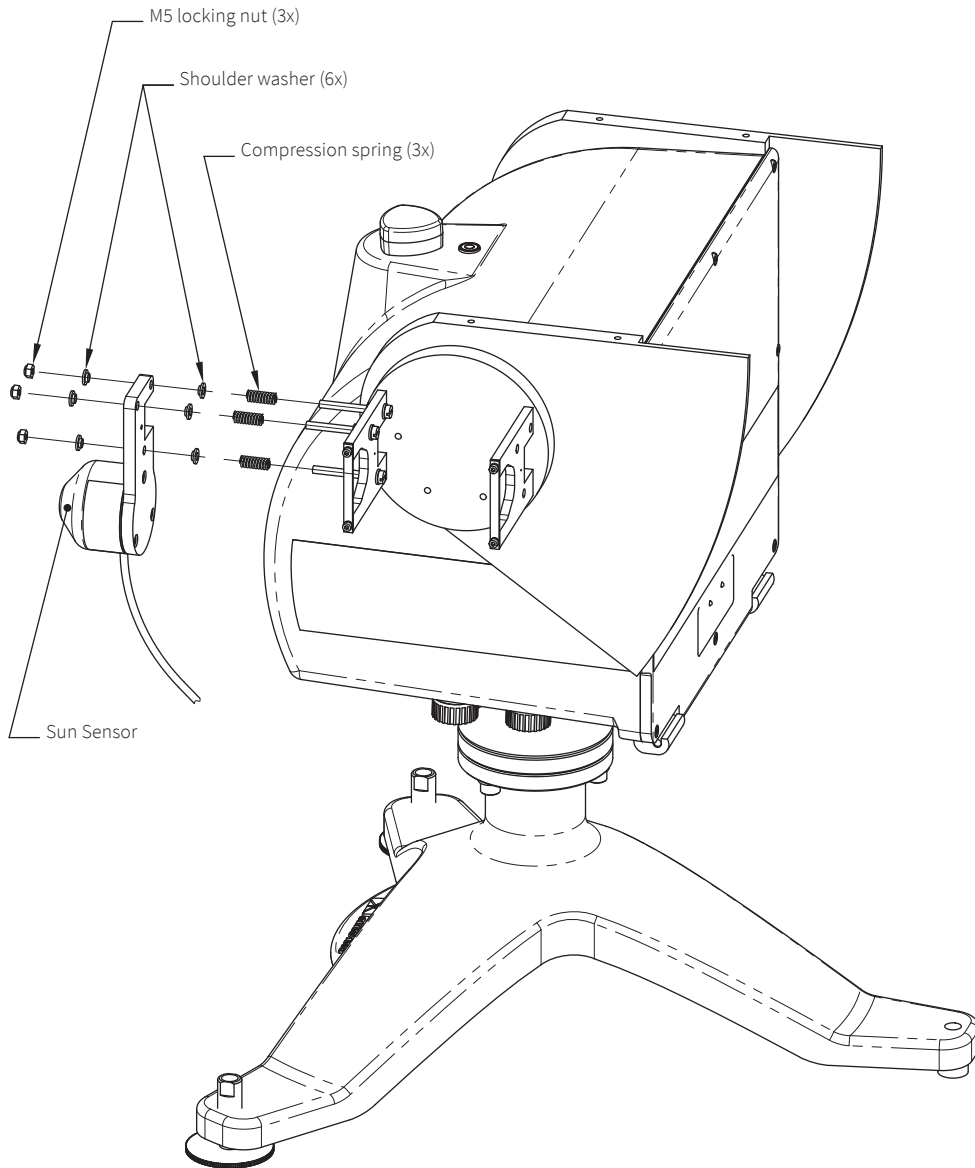

Figure 3.12: Mounting the sun sensor

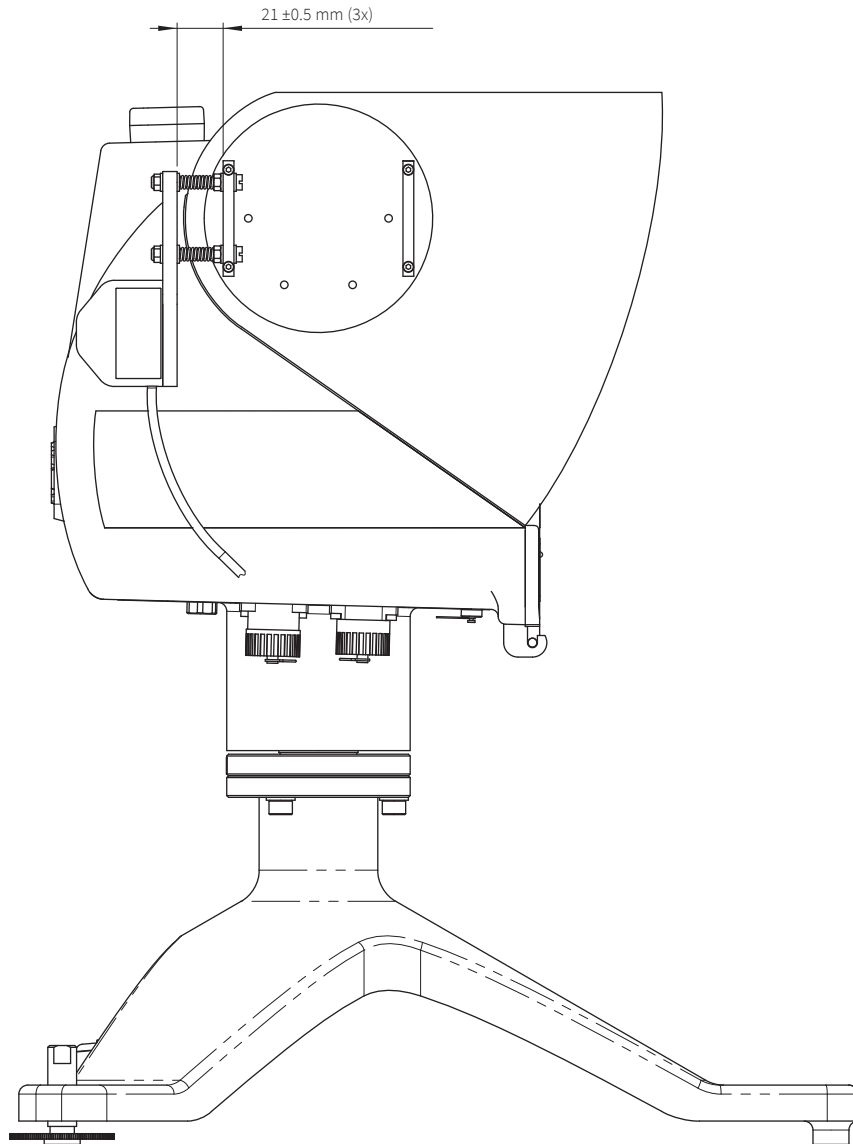

Figure 3.13: Adjustment of the sun sensor

Note Before inserting the cable please check if the pyrheliometer is perfectly aligned and the M8 bolts are secured. Then, unscrew the cap from the sun sensor connector on the underside of the SOLYS and connect the sensor connector.

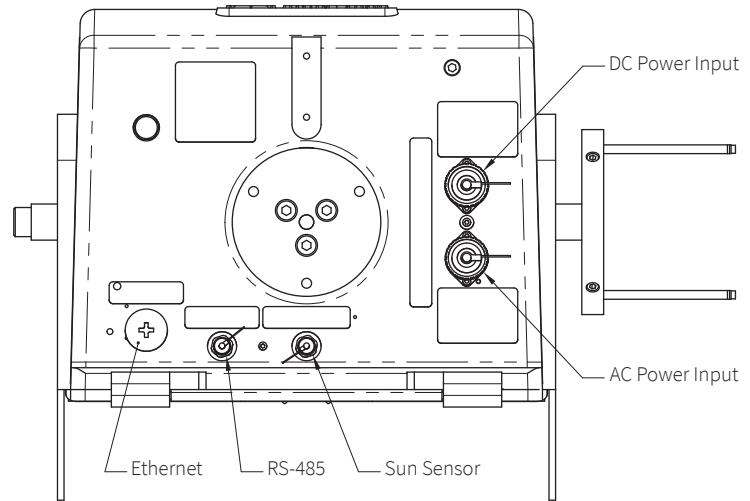

Figure 3.14: The bottom of the SOLYS

When the sun sensor is connected for the first time, the tracker will reset (go to its home position) and return and starts using the sun sensor. Now its needs to be aligned.

3.11.1 Alignment of the sun sensor

It is required to have the SOLYS correctly tracking the sun before adjusting the sun sensor.

The sun sensor can only be aligned when the direct radiation is above 300 W/m^2 . This can be checked by the status LED. When the sun sensor is connected and the status LED is green the radiation is above 300 W/m^2 , when blinking the radiation is too low to align the sun sensor. Once the sun sensor is connected and the direct radiation is above 300 W/m^2 it will correct the tracker position. The initial position of the sun sensor as indicated in figure 3.13 should be 21 mm from the pyrheliometer mounting clamp. This initial adjustment is important; otherwise the sun sensor is too far off to find the sun.

When enough sun is present the sun sensor can be fine-tuned. The correct position can be obtained from the alignment target of the pyrheliometer. If no pyrheliometer is present the alignment targets of the two mounting brackets can be used. Both brackets have a hole and the light beam falling through the first hole should make a circle just around the second hole.

The information from the sun sensor is updated every 10 seconds, so after a changed alignment this interval should be waited before the new position is affected. Of course when the green status LED starts blinking no further adjustments are possible because the direct radiation is too low. The position of the sun sensor has to be adjusted using the 3 screws that hold the sun sensor in place. It is best to start adjusting one of the screws half a turn to see the effect. If the sunspot moves further away from the target, the direction of rotation should be reversed. Every time wait 10 seconds for the SOLYS to update its position according to the new sun sensor angle. Adjust all three sun sensor screws until the alignment target is exactly positioned at the sun.

When the sun sensor is disconnected the SOLYS has to recalculate its position and will first move to the home position before starting tracking again. When reconnected the sun sensor information will be used directly (after 10 seconds) when the status LED is constantly green.

The position information from the sun sensor is not stored because the misalignment can be different for different positions (different times of the day). The sun sensor will start every day with active tracking when the direct radiation is above the 300 W/m^2 .

3.12 Shading ball assembly

The shading ball assembly is comprised of several components which, when assembled to the SOLYS, provide a mechanical assembly to ensure accurate shading during normal solar tracking operations.

Listed below is a recommended sequence of the assembly.

First, install the lower pivot bar on the underside of the SOLYS with the designated screws.

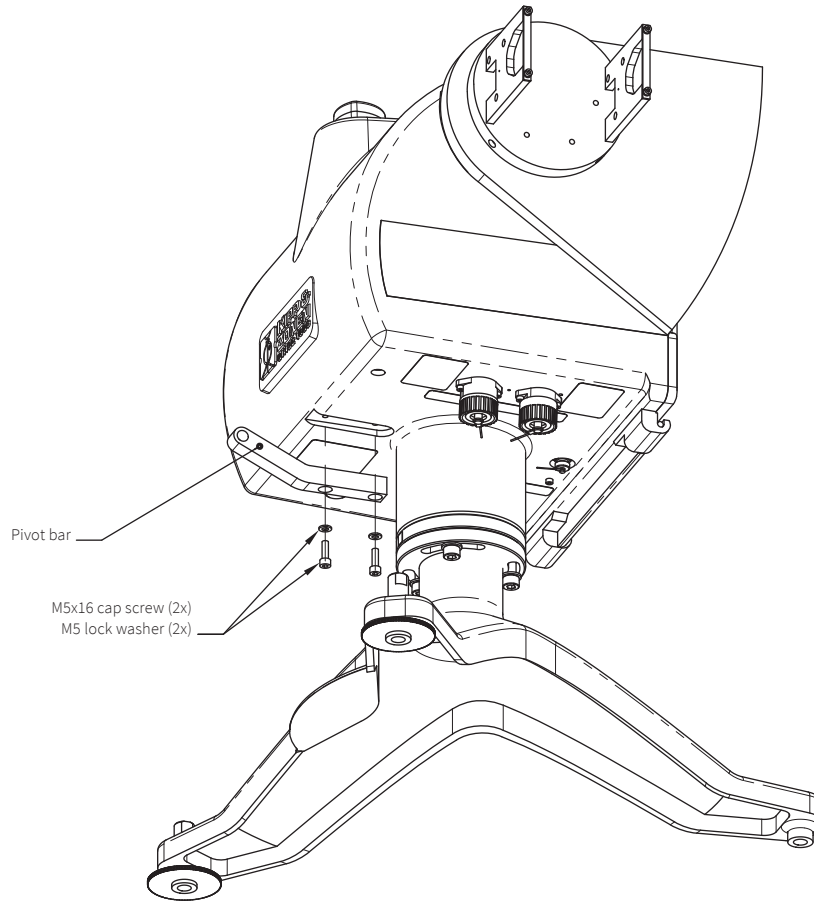

Figure 3.15: Mounting of the pivot bar

- Attach both the shading drive arms with the designated screws. Ensure the counter weights are facing down. Do not completely tighten the screws yet, some movement for installing the T-bar is required, see figure 3.16.
- Install the T-bar (without ball rods). Install the plastic shoulder washers onto the threaded studs of the T-bar. Insert the shoulder washers into the side arm end holes. Install the outer flat washers and the locking nuts ensuring that all the bushings are properly seated into the side arms. Only loosely install the locking nuts at this stage.
- Tighten the shading drive arm screws and mount the second side plate to the axis with its two screws after aligning the two shading drive arms, see figure 3.16.
- Now tighten the T-bar locking nuts until most of the clearance is gone between the arms and shoulder washers. Do not tighten snugly, ensure that the T-bar rotates freely but has minimal sideways movement.
- Install the shading drive arm to the T-bar. Install the shoulder washers into the holes as shown. Only tighten the locking nut to minimize clearances, ensure free rotational movement.

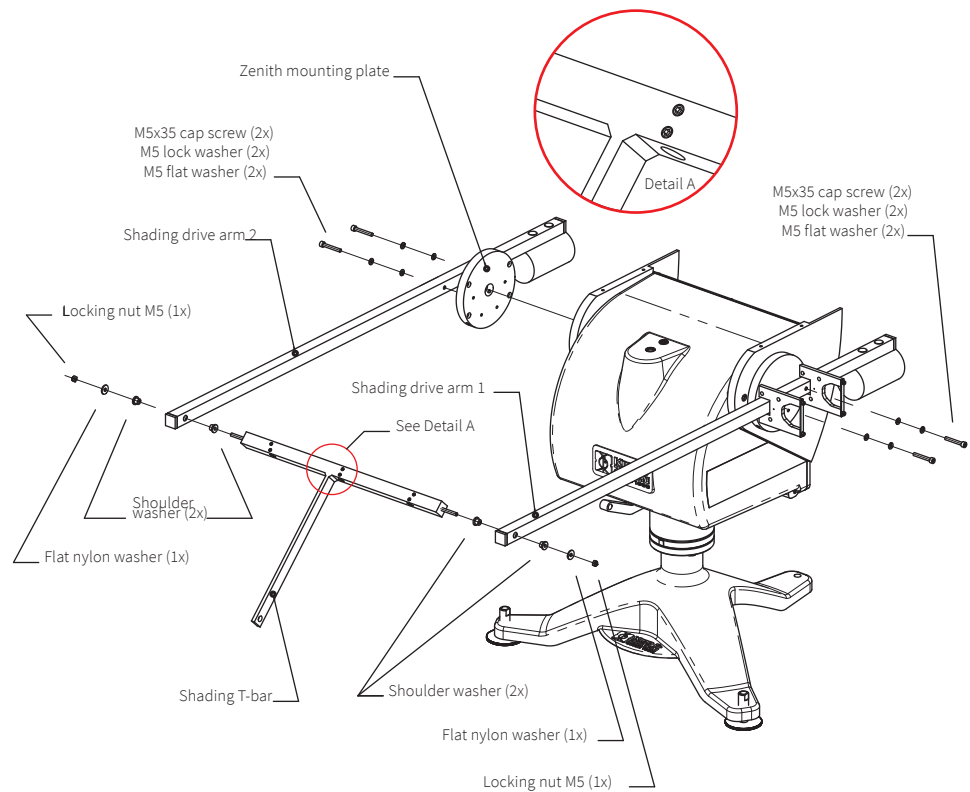

Figure 3.16: Mounting of the shading drive arm

- Install the the shading support arm to the T-bar and shading pivot bar hole with the nylon washers and locking nut. Only tighten the locking nut to minimize clearances, ensure free rotational movement.

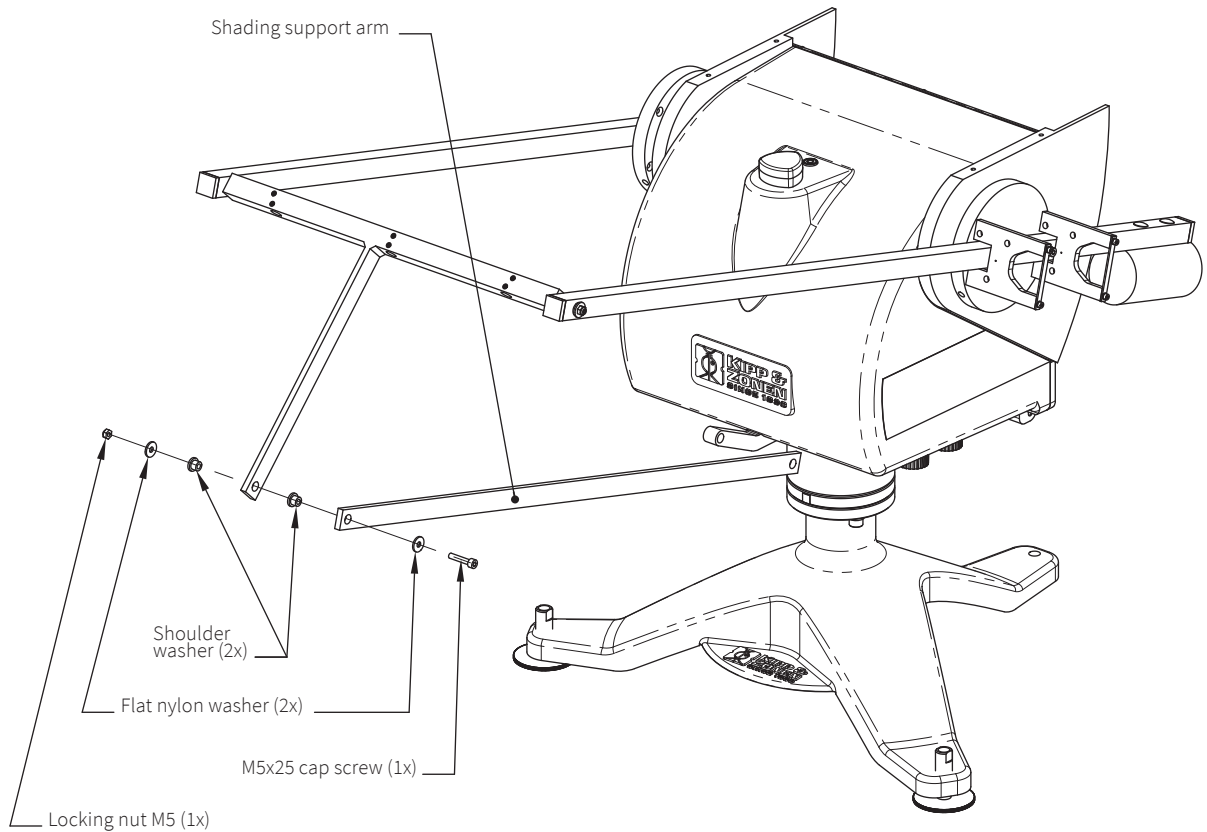

Figure 3.17: Mounting of the top part of the shading support arm

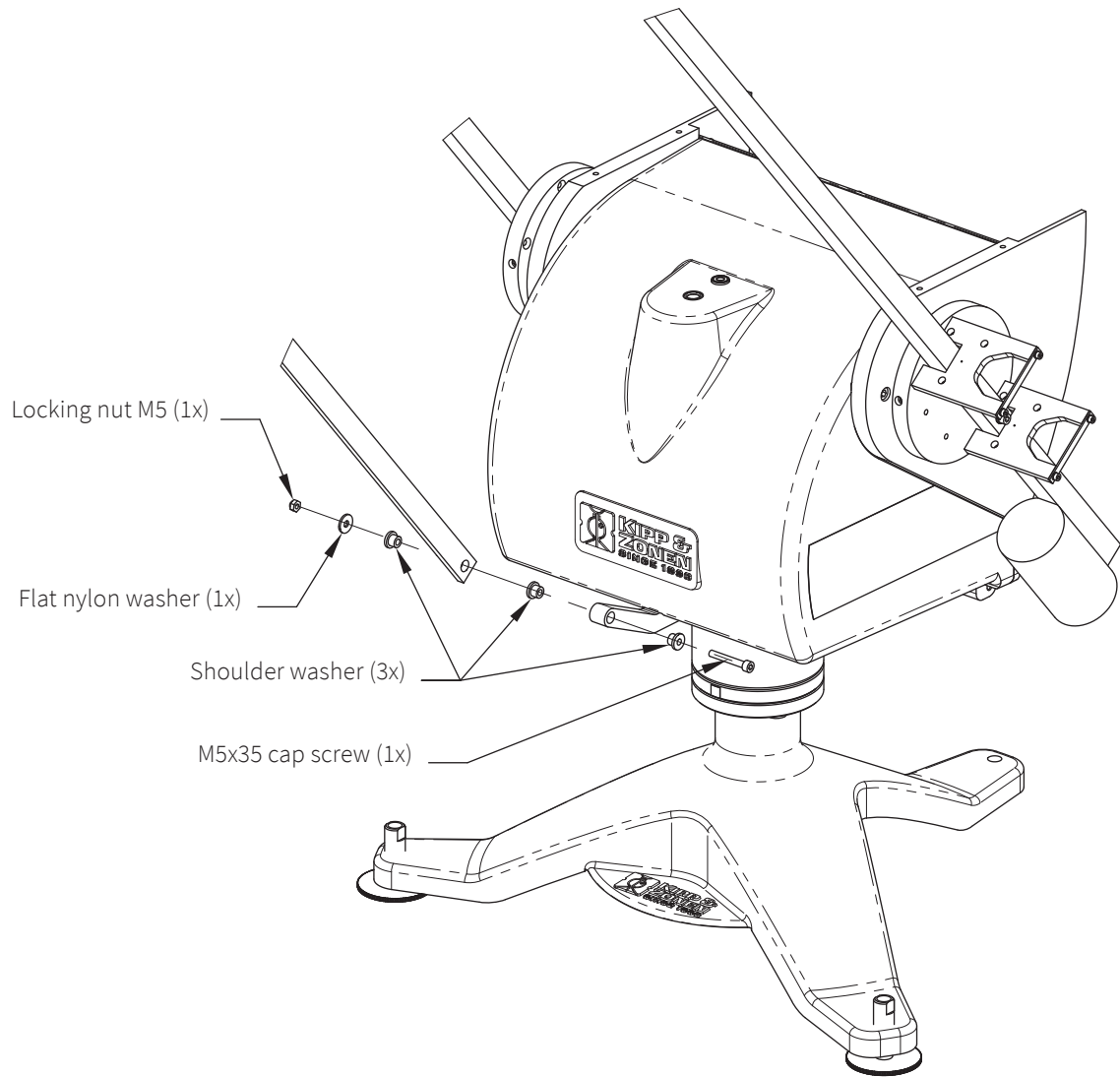

Figure 3.18: Mounting of the lower part of the shading support arm

3.13 Top mounting plate assembly

The next figure indicates how to mount the top mounting plate.

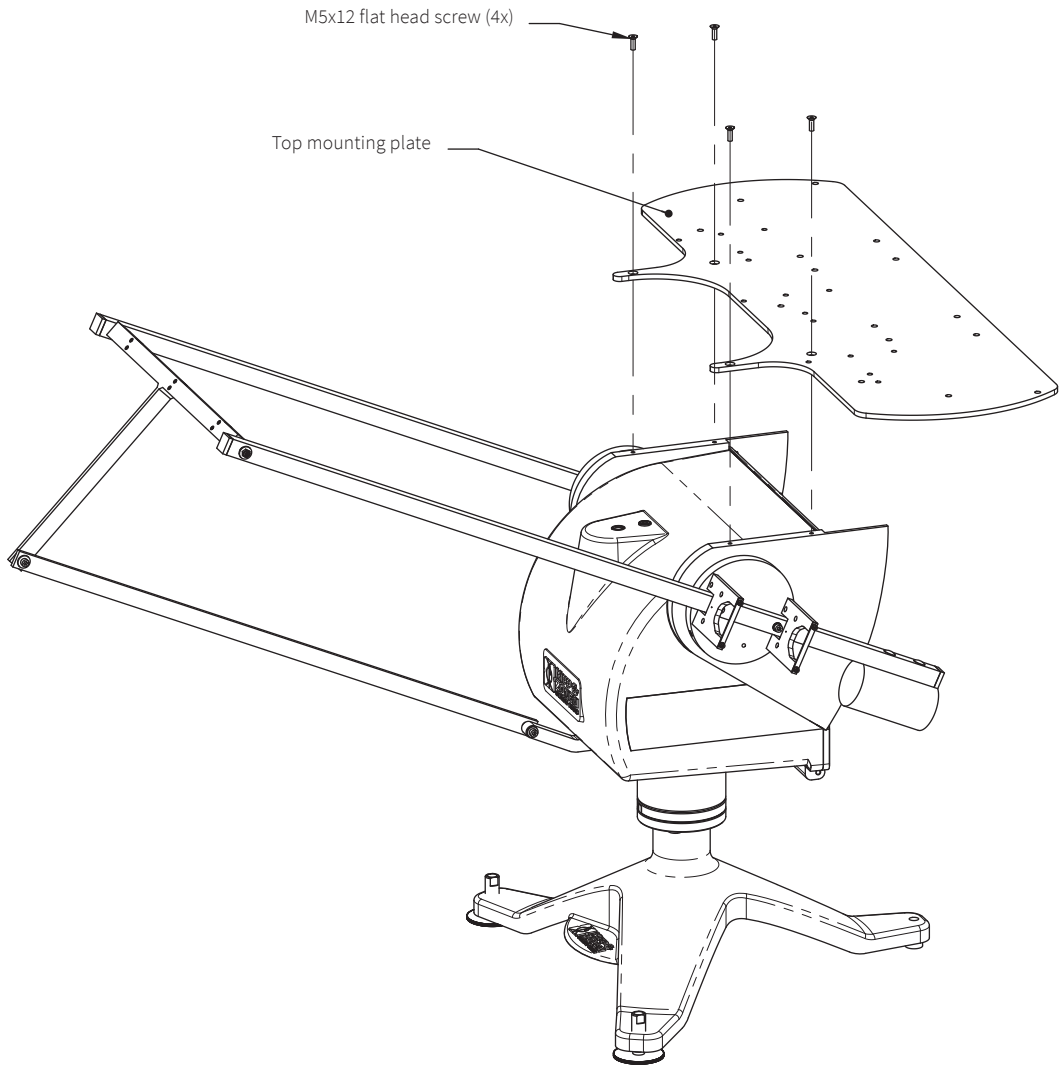

Figure 3.19: Mounting the top mounting plate

3.14 Mounting Kipp & Zonen radiometers without ventilation unit

The figure below indicates in detail the mounting holes for mounting up to three Kipp & Zonen radiometers.

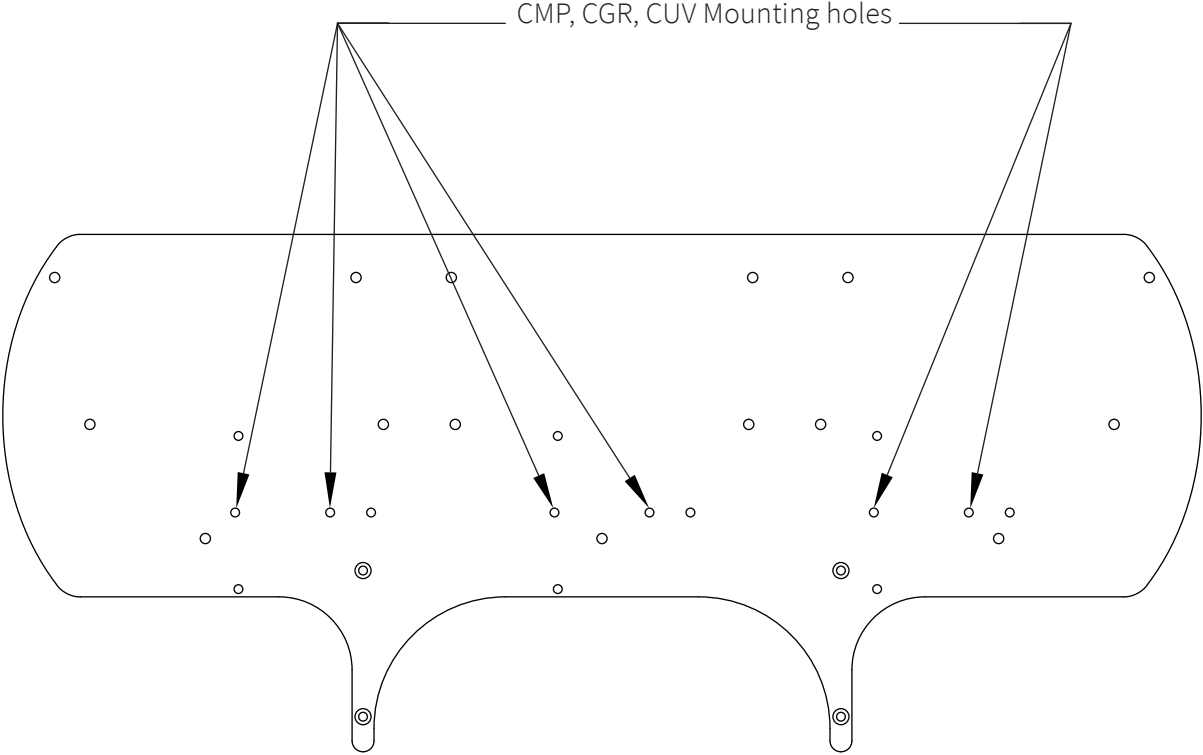

Figure 3.20: Kipp & Zonen radiometers mounting holes without ventilation unit

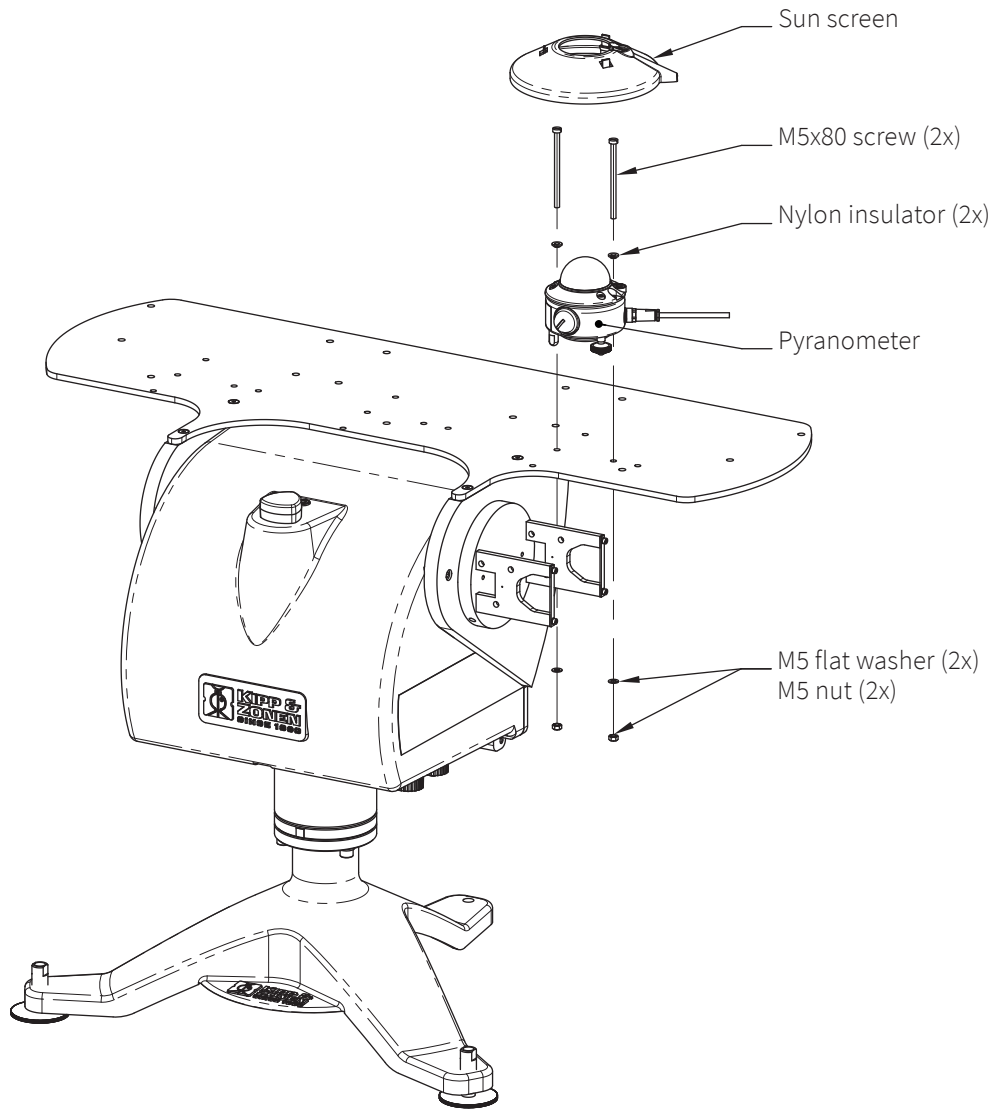

Figure 3.21: Kipp & Zonen radiometers mounting holes without ventilation unit

3.15 Mounting UVS instruments

The next two illustrations are showing the location of the holes inside the top mounting plate, the setup for the shadow balls and a total view for mounting the UVS instruments on top of the SOLYS.

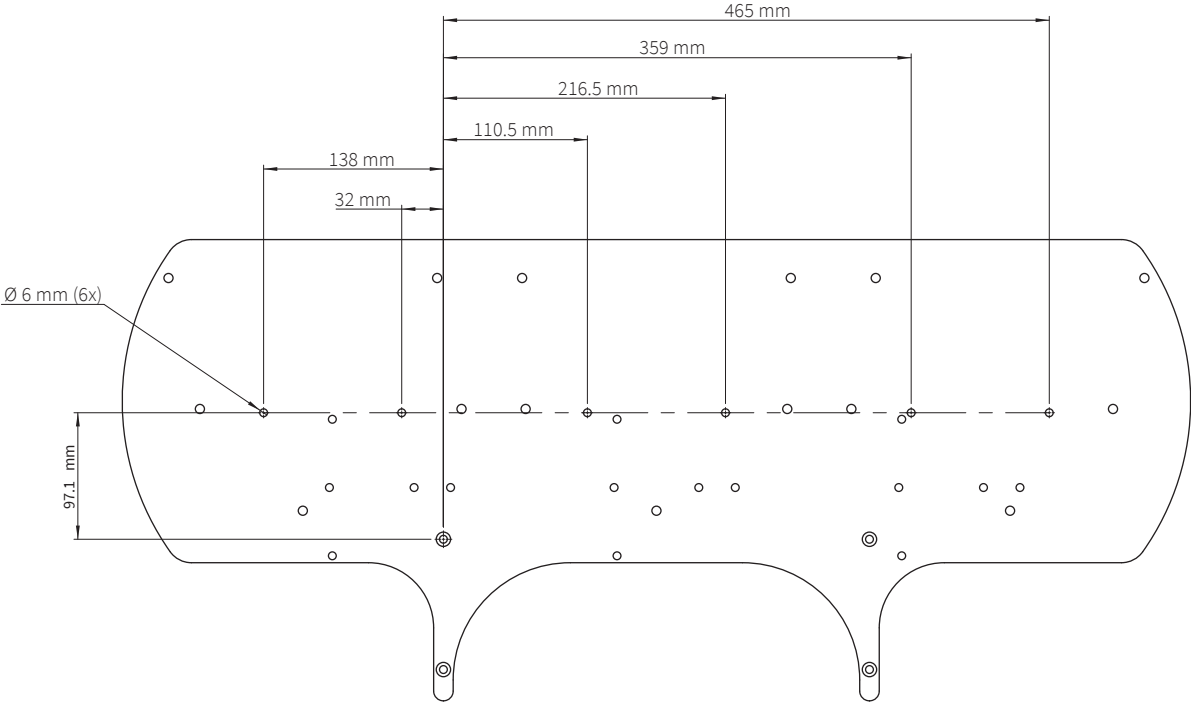

Figure 3.22: Location of the holes inside the top mounting plate

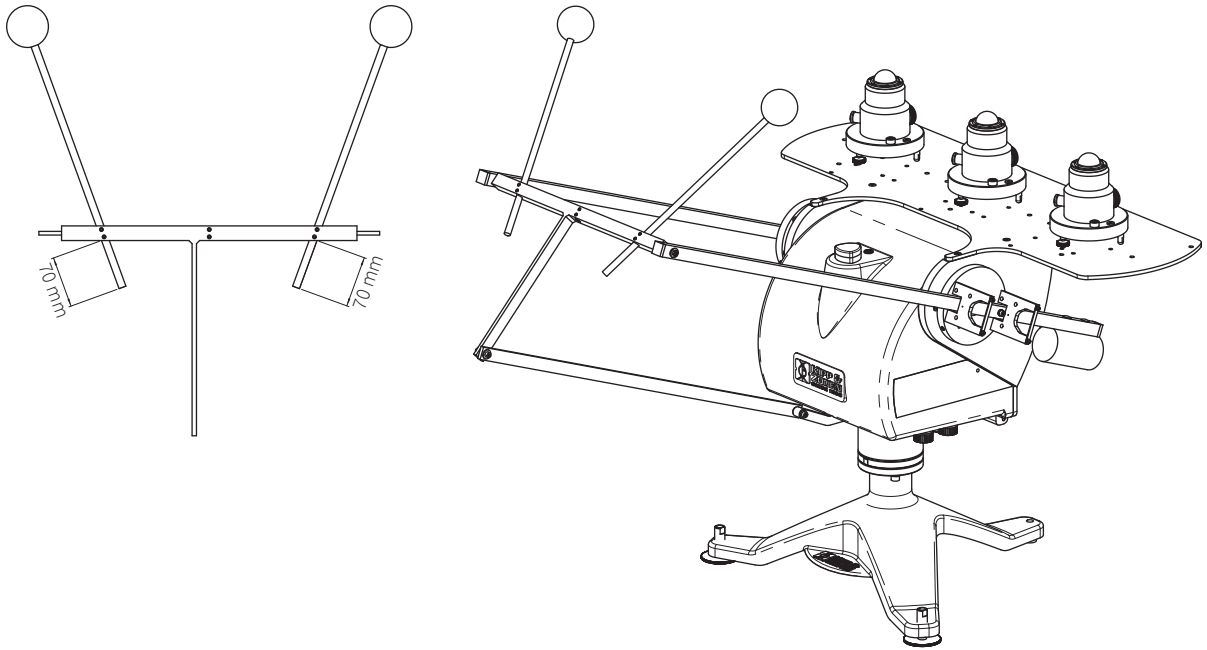

Figure 3.23: The setup for the shadow balls

3.16 Mounting Kipp & Zonen radiometers with ventilation unit

The next illustration indicates in detail the mounting holes for mounting up to three Kipp & Zonen ventilation units.

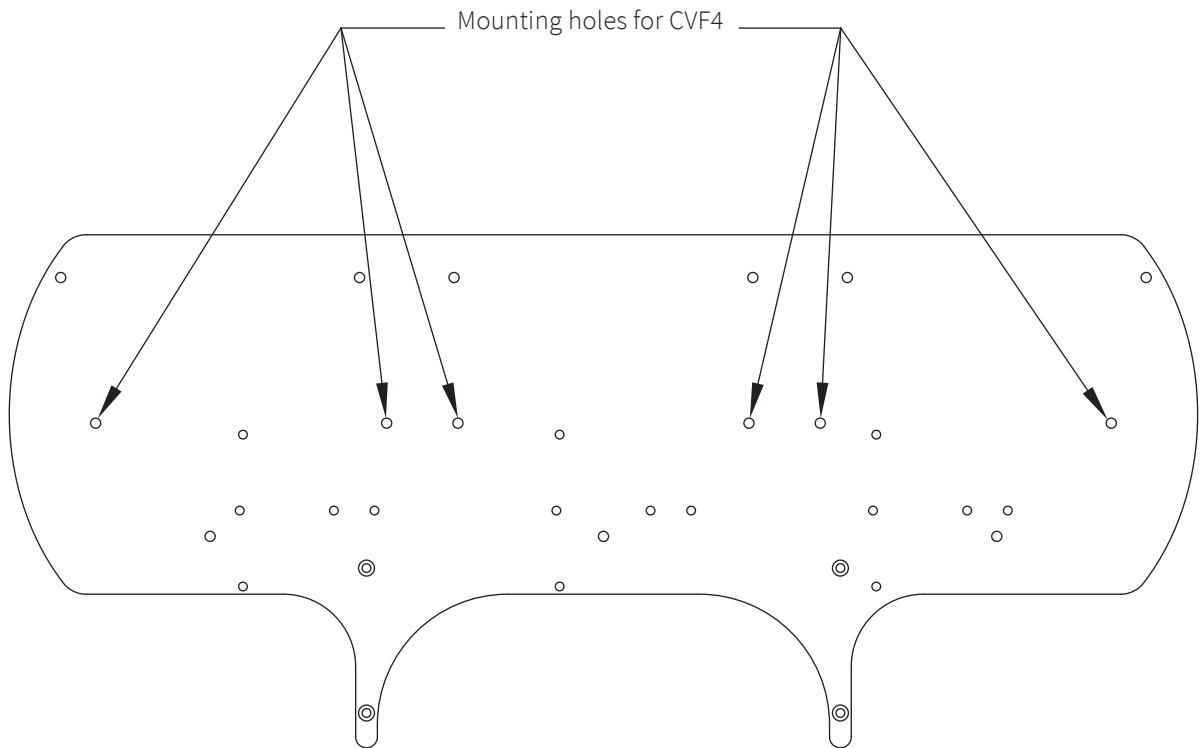

Figure 3.24: Kipp & Zonen radiometers mounting holes with ventilation unit

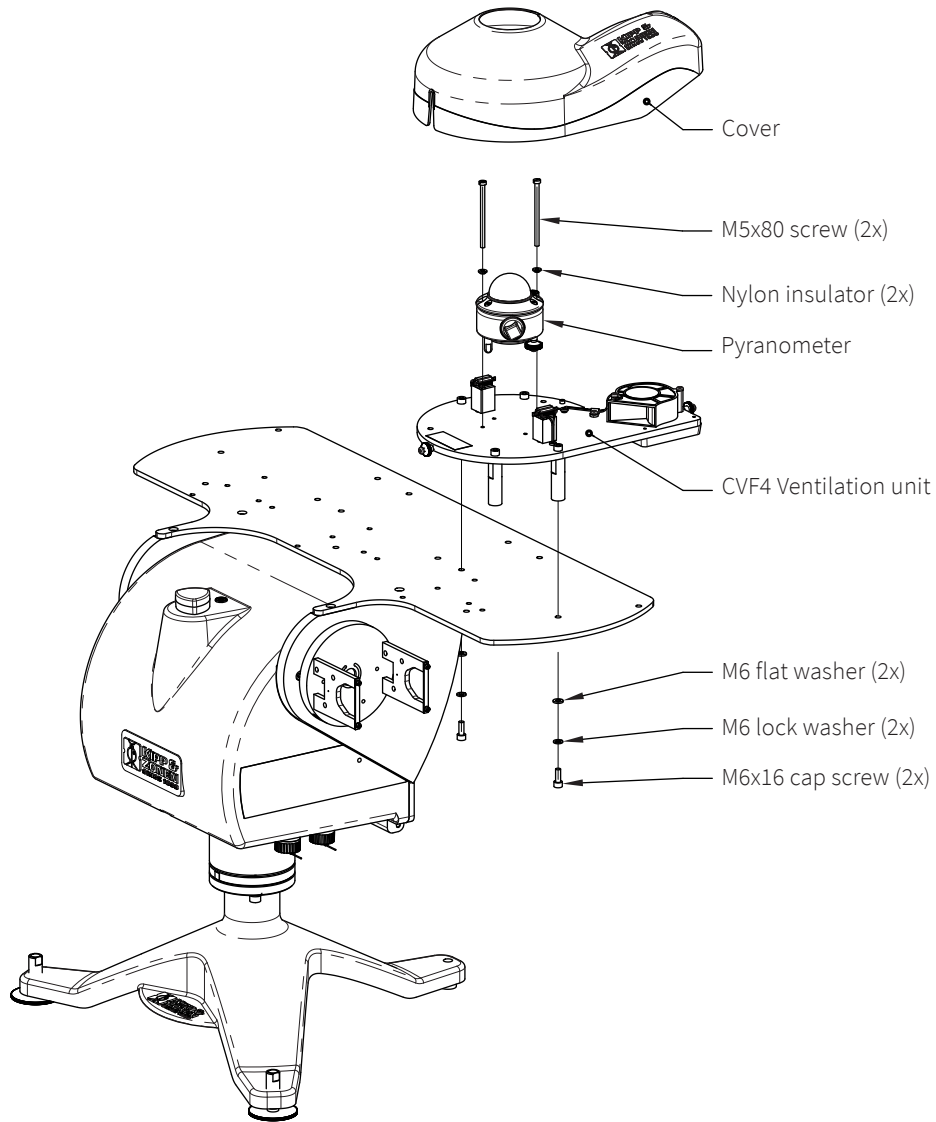

Figure 3.25: Kipp & Zonen pyranometer with ventilation unit diagram

3.17 Mounting Eppley radiometers with or without ventilation unit

The next two illustrations indicate the mounting holes required to mount an Eppley radiometer to the top mounting plate.

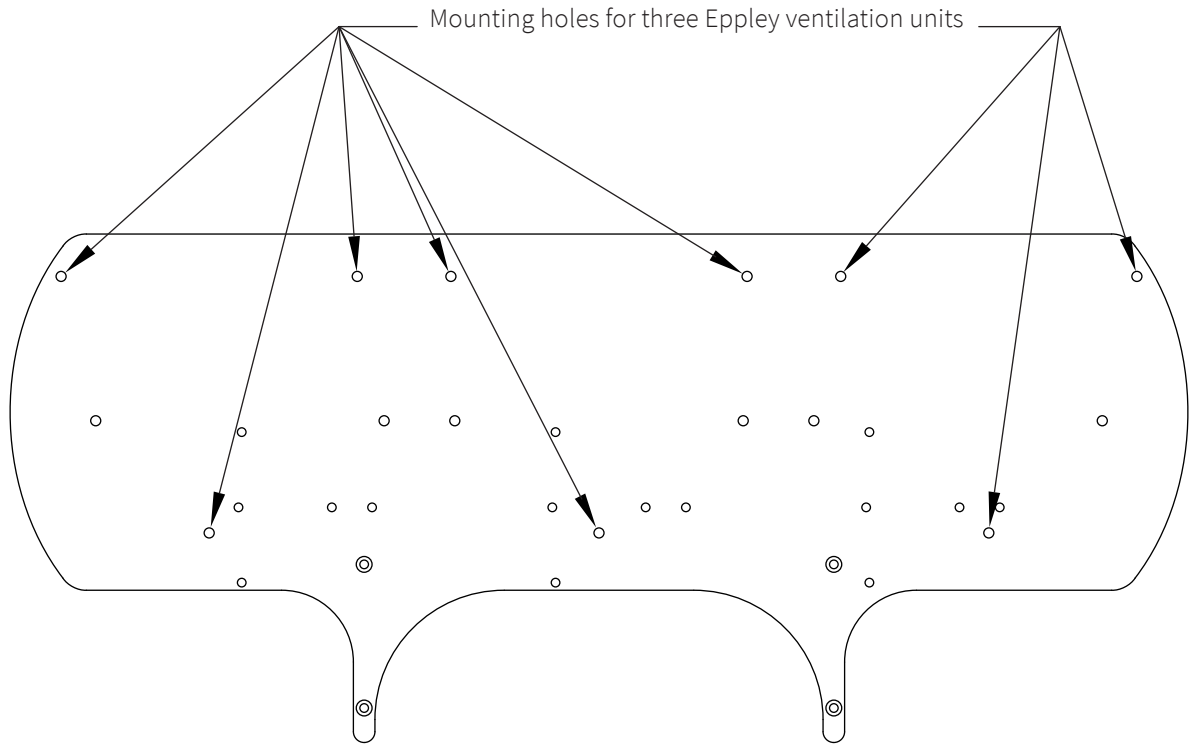

Figure 3.26: Mounting of ventilated Eppley instruments on the top mounting plate

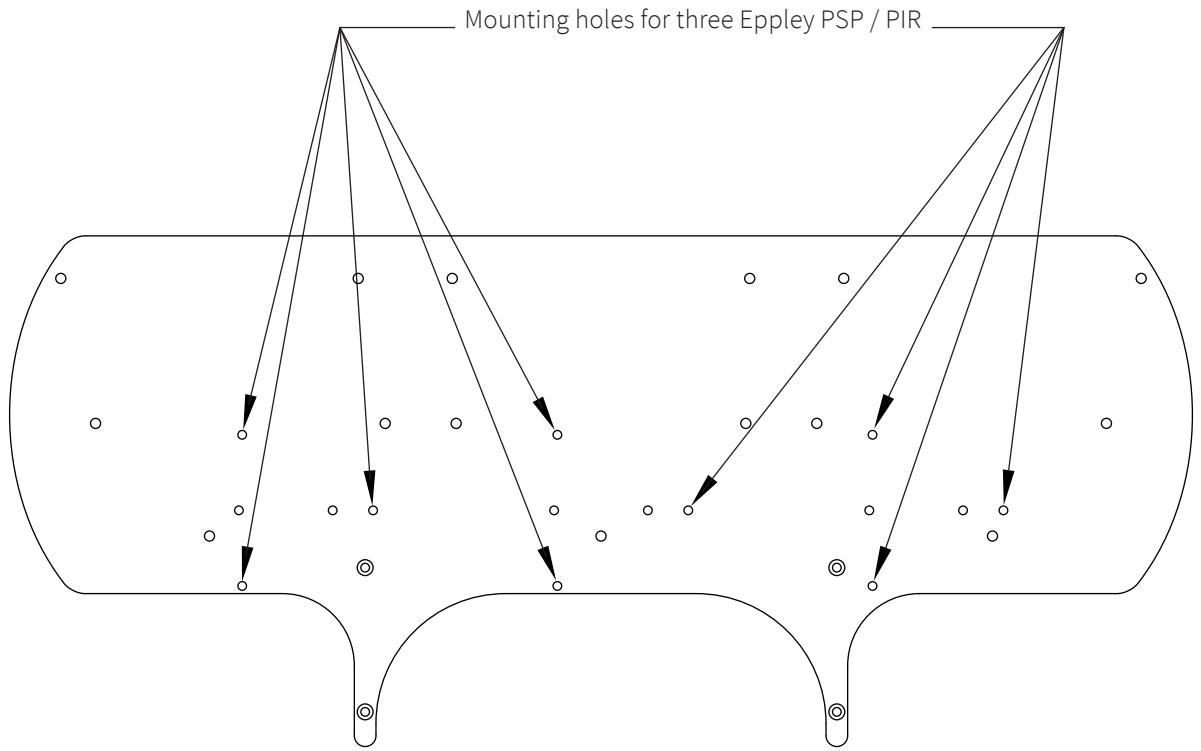

Figure 3.27: Mounting of Eppley radiometers on the top mounting plate

3.18 Large top mounting plate dimensions

The shading assembly is equipped with a top mounting plate. If a top mounting plate is required without shading assembly it can be ordered separately. The part number for the top mounting plate is 0367709.

It might be necessary to adjust the large top mounting plate for suiting specific instruments. The next illustration is the mechanical drawing of the large top mounting plate.

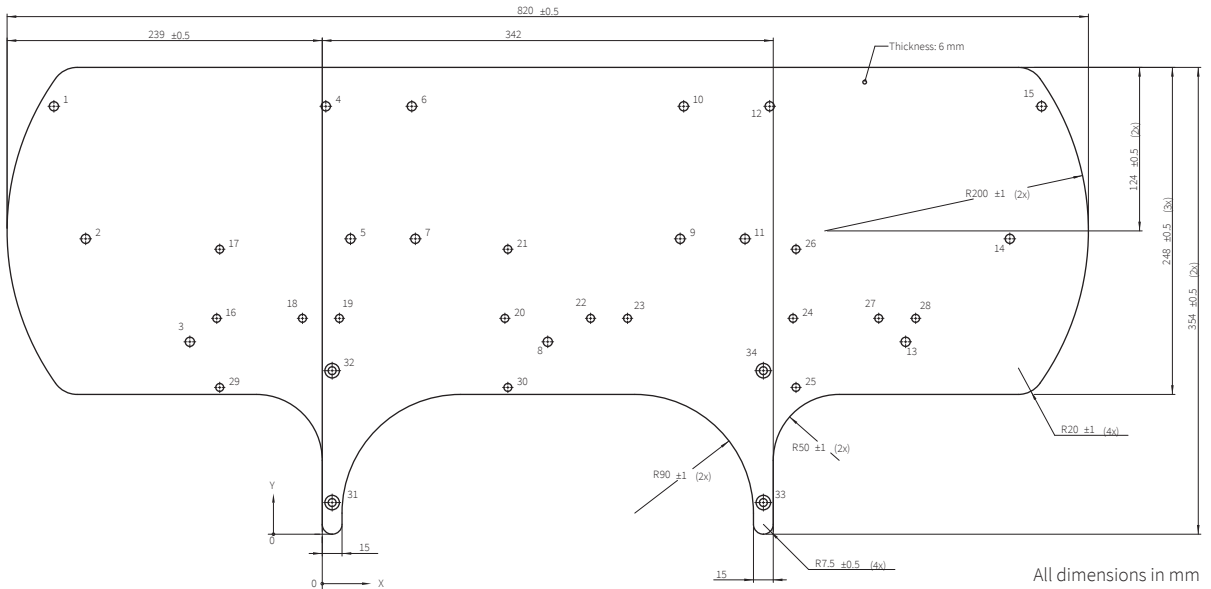

Figure 3.28: Large top mounting plate dimensions

	X ± 0.2	Y ± 0.2	SIZE
1	-203.5	324.5	$\text{Ø}7 \pm 0.2$
2	-179.4	224	
3	-100.4	145.9	
4	2.7	324.5	
5	21.4	224	
6	67.9	324.5	
7	70.6	224	
8	171	145.9	
9	271.4	224	
10	274.1	324.5	
11	320.6	224	
12	339.3	324.5	
13	442.4	145.9	
14	521.4	224	
15	545.5	324.5	
16	-80	163.7	$\text{Ø}6 \pm 0.2$
17	-77.7	216.1	
18	-15	163.7	
19	13	163.7	
20	138.5	163.7	
21	140.8	216.1	
22	203.5	163.7	
23	231.5	163.7	
24	357	163.7	
25	359.3	111.3	
26	359.3	216.1	
27	422	163.7	
28	450	163.7	
29	-77.7	111.3	
30	140.8	111.3	
31	7.5	24	$\text{Ø}6 \pm 0.2 \times \text{Ø}11 \pm 0.2 \times 90^\circ$
32	7.5	124	
33	334.5	24	
34	334.5	124	

3.19 Shading ball rods assembly

Install the shading ball rods by sliding them into the designated holes.. Fine-tuning of the ball rods must be done later in the installation after the verification of levelling procedure. Do not over-tighten the locking screws. It would make fine-tuning adjustments difficult later in the procedure.

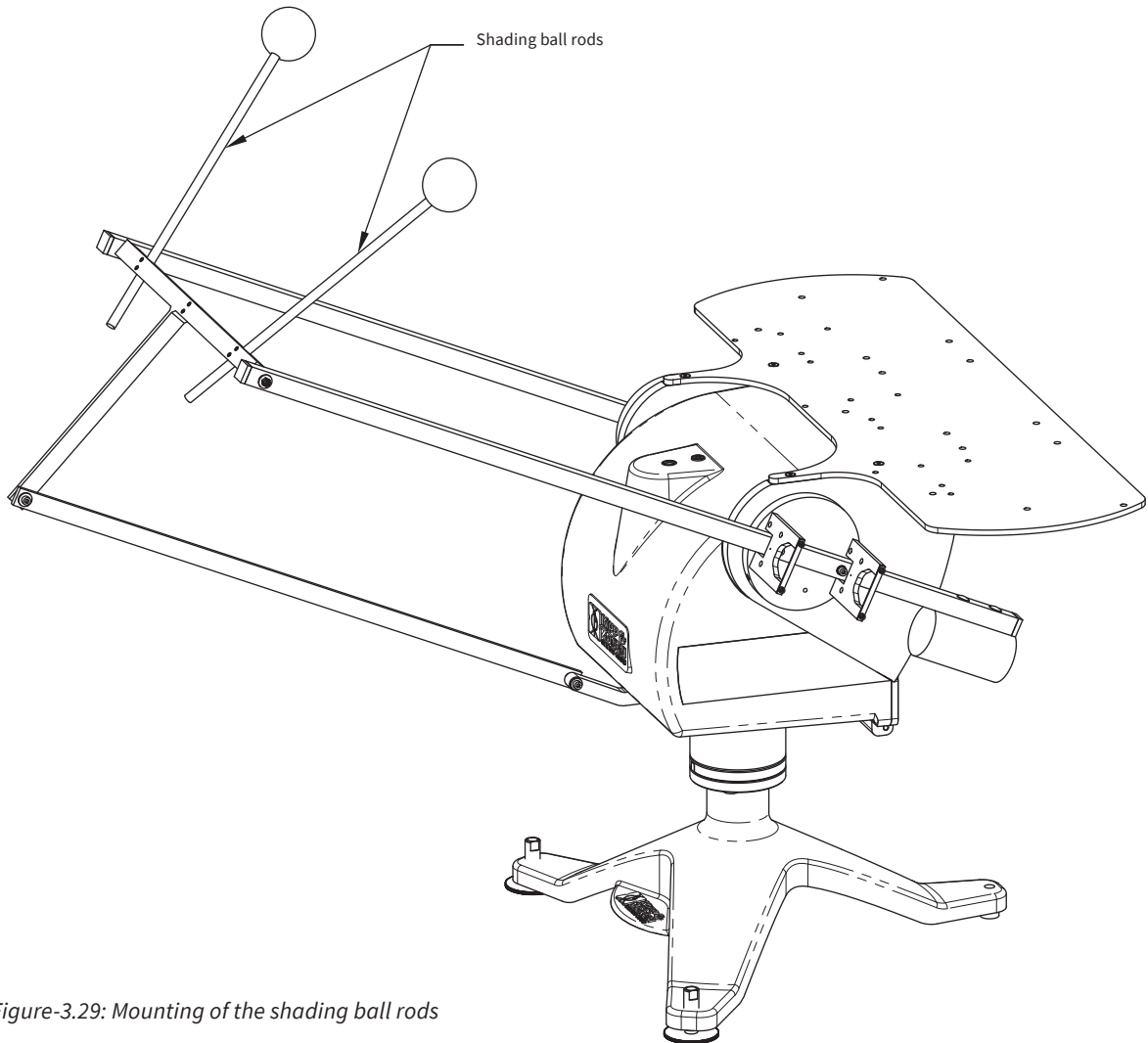

Figure-3.29: Mounting of the shading ball rods

The position of the shading balls depends on the type (height) of the sensor.

In figure 3.30 and 3.31 two different positions are described for pyranometers and pyrgeometers with and without ventilation unit. Be sure to use the right position in your situation. Fine tuning is done when the sun is present.

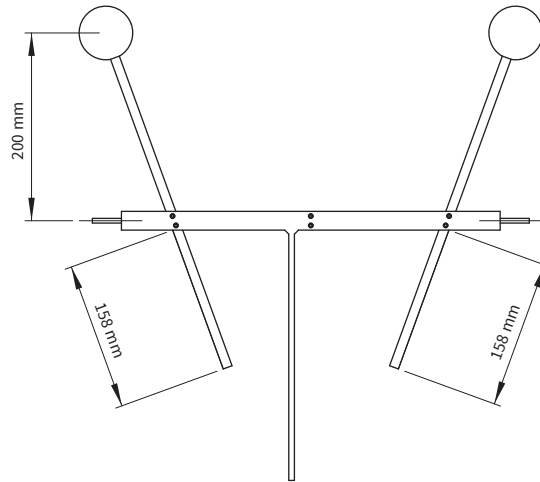

Figure 3.30: Shading ball rods for Kipp & Zonen radiometers without ventilation unit

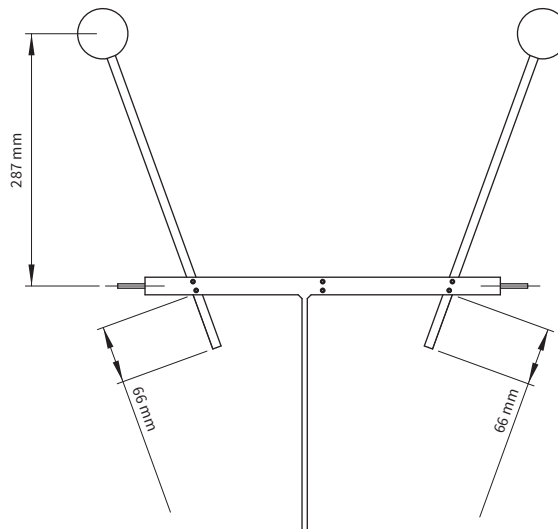

Figure 3.31: Shading ball rods for Kipp & Zonen radiometers with ventilation unit

Note It's important for the detector of the instrument to be fully shaded.
This can be helpful during installation of third party radiometers.

Tip At this time fine adjust the shading ball rods (of the optional pointing & shading ball assembly) such that the balls cast shadows fully covering the sensing elements of the radiometer on the top mounting plate.

3.20 Tilted pyranometer mounting kit targeting the PV market

Pyranometer mounting for measuring tilted (tracking) global radiation.

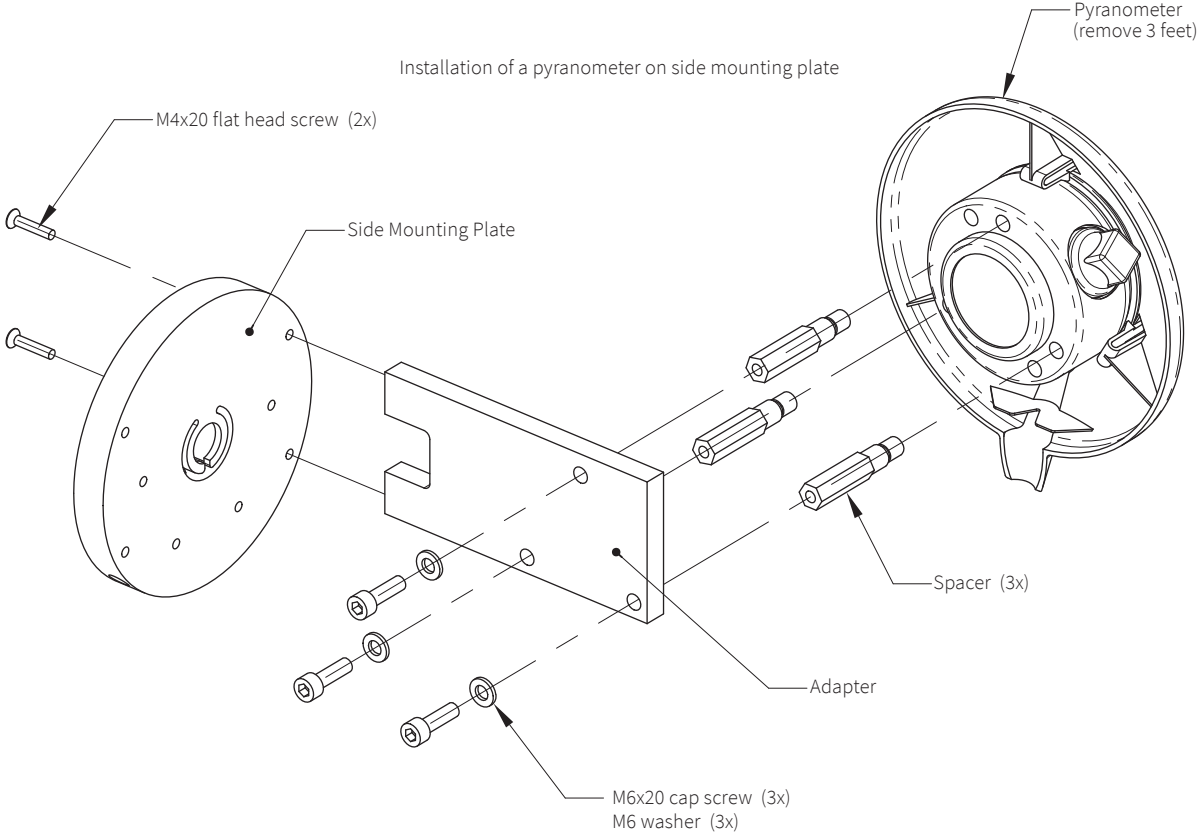

Figure 3.32: Tilted pyranometer mounting kit

3.21 Small top mounting plate for installing a single Kipp & Zonen radiometer

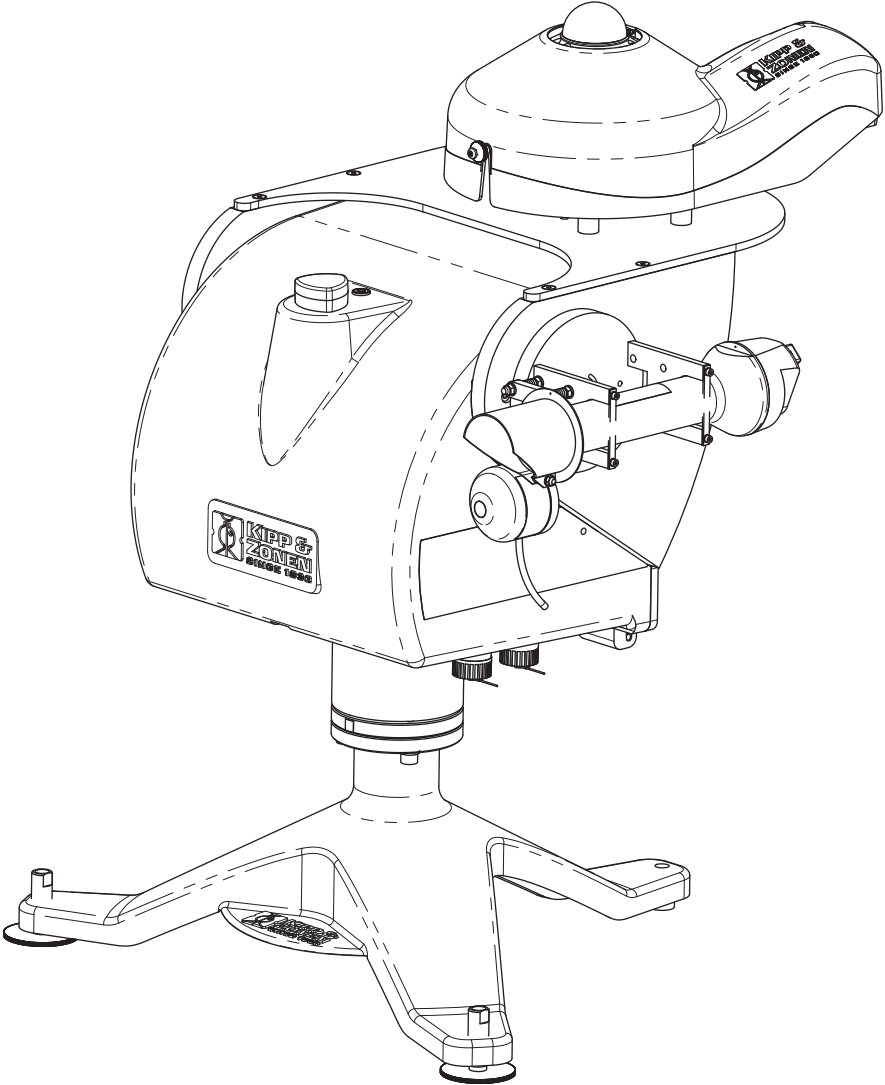
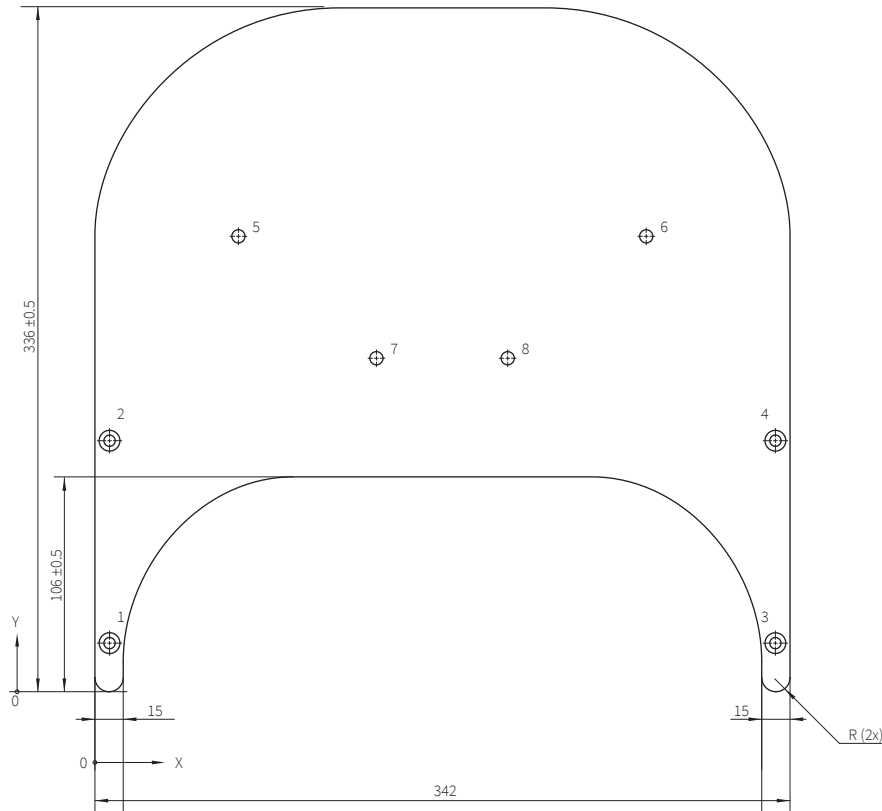

Figure 3.33: Small top mounting plate



	X ±0.2	Y ±0.2	SIZE
1	7.5	24	Ø6 ±0.2 x Ø11 ±0.2 x 90°
2	7.5	124	
3	334.5	24	
4	334.5	124	
5	70.6	224	Ø7 ±0.2
6	271.4	224	
7	138.5	163.7	Ø6 ±0.2
8	203.5	163.7	

3.22 Cold cover

The bare SOLYS Gear Drive is specified up to -50°C at no wind speed. Because wind is always present a cold cover is strongly recommended. With the SOLYS Gear Drive cold cover a constant (or average) wind speed up to 20 m/s is allowed. It also significantly reduces the required (heating) power of the SOLYS Gear Drive. The SOLYS Gear Drive internal heater is switched off when the internal temperature is above 5°C .

The cold cover can be mounted after the installation of the SOLYS Gear Drive is done. The cold cover slides between the housing and the top mounting plate. For all connectors, flaps with Velcro strips are present. For not used connectors, the Velcro strips have to be closed properly.



Figure 3.34: The cold cover

3.23 Sun shield

When the SOLYS is used in extreme climates the temperature could get above 55°C. To protect the SOLYS in this case for direct radiation a sun shield is available. This allows for use in temperatures up to +60°C. The sun shield also protects the bubble level for direct radiation. The sun shield can be used in combination with the shading assembly.

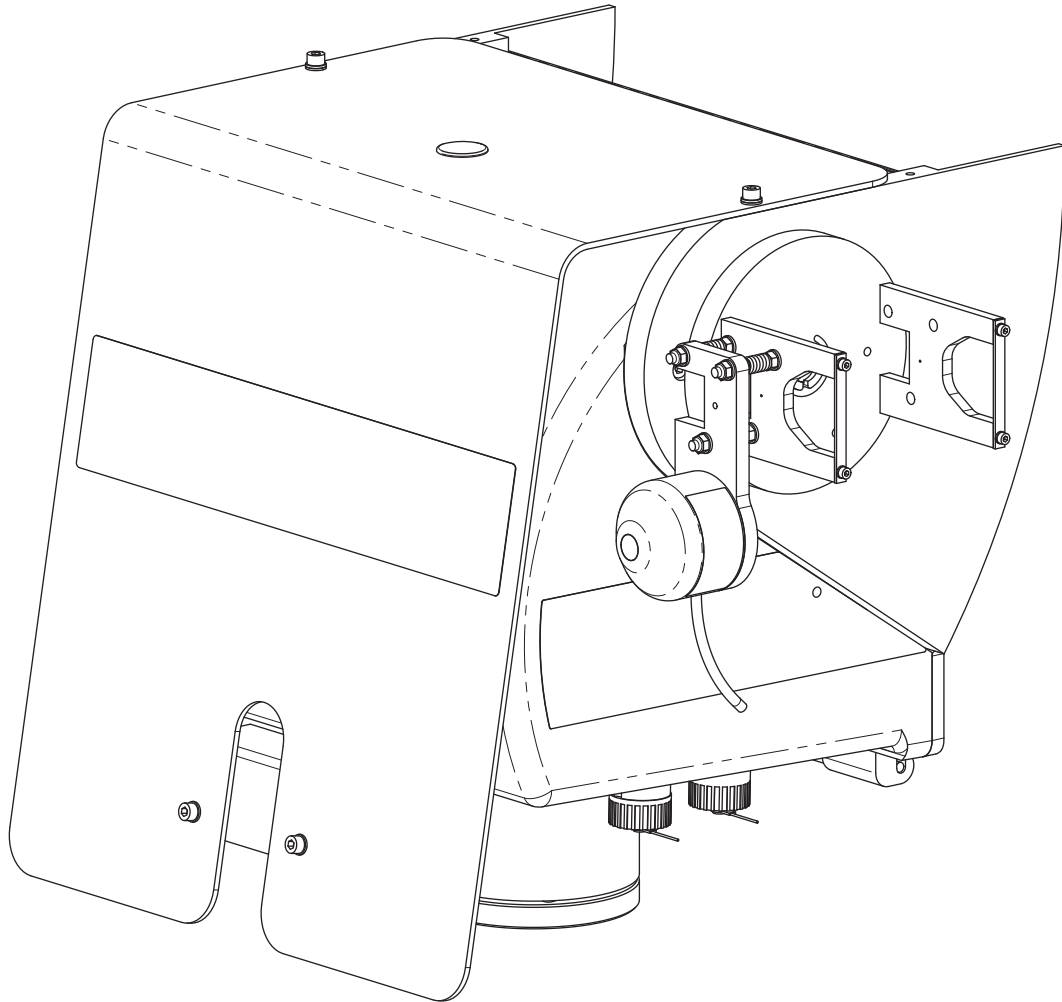

Figure 3.35: The sun shield

3.24 How to guide the cables

The next illustration shows the best way to guide all your cables. It's strongly advised to have the proper cable length as indicated below, so that the SOLYS can move freely throughout the entire year. As a security check, the SOLYS will make a 540 degree rotation lap when powering up.

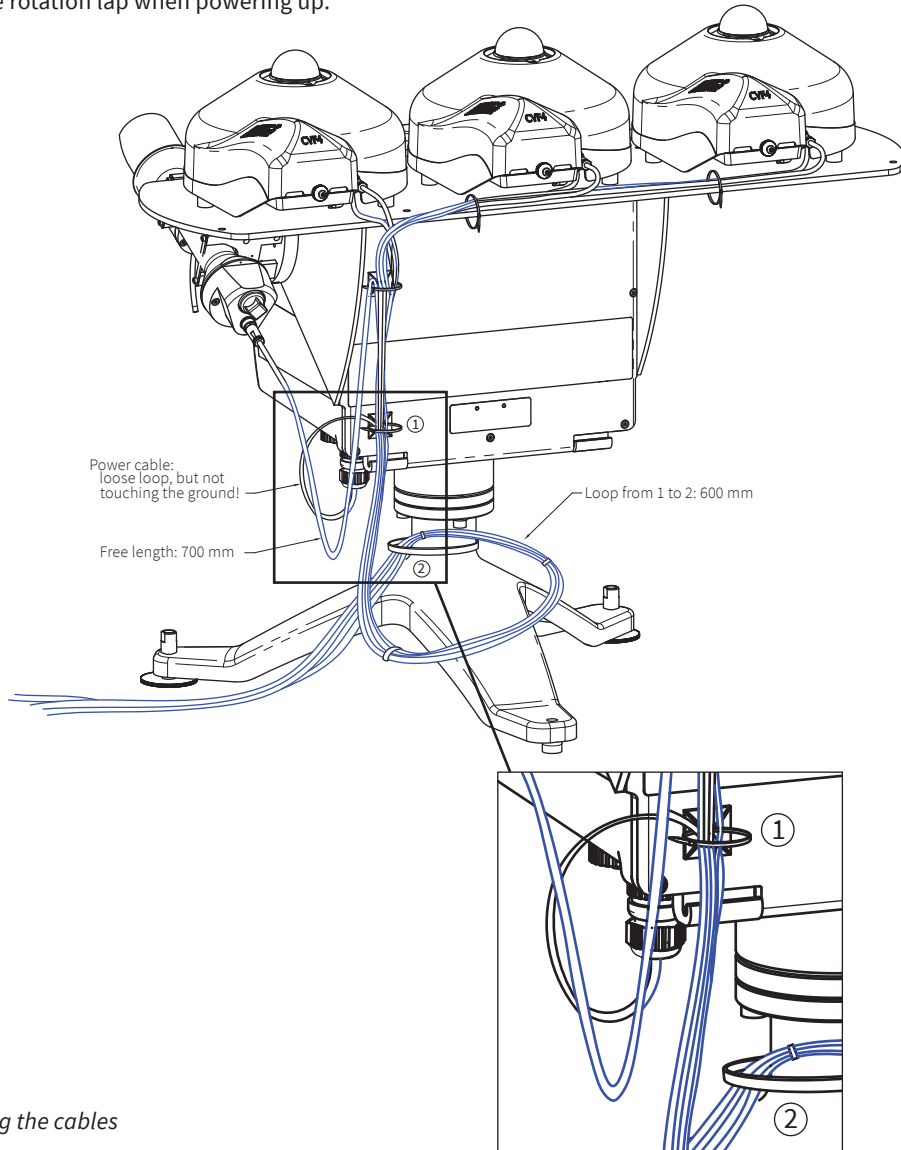

Figure 3.36: Guiding the cables

3.25 Partnumbers shading assembly

The next illustration shows the part numbers for each of the separate components from the shading assembly in case a part is broken or damaged.

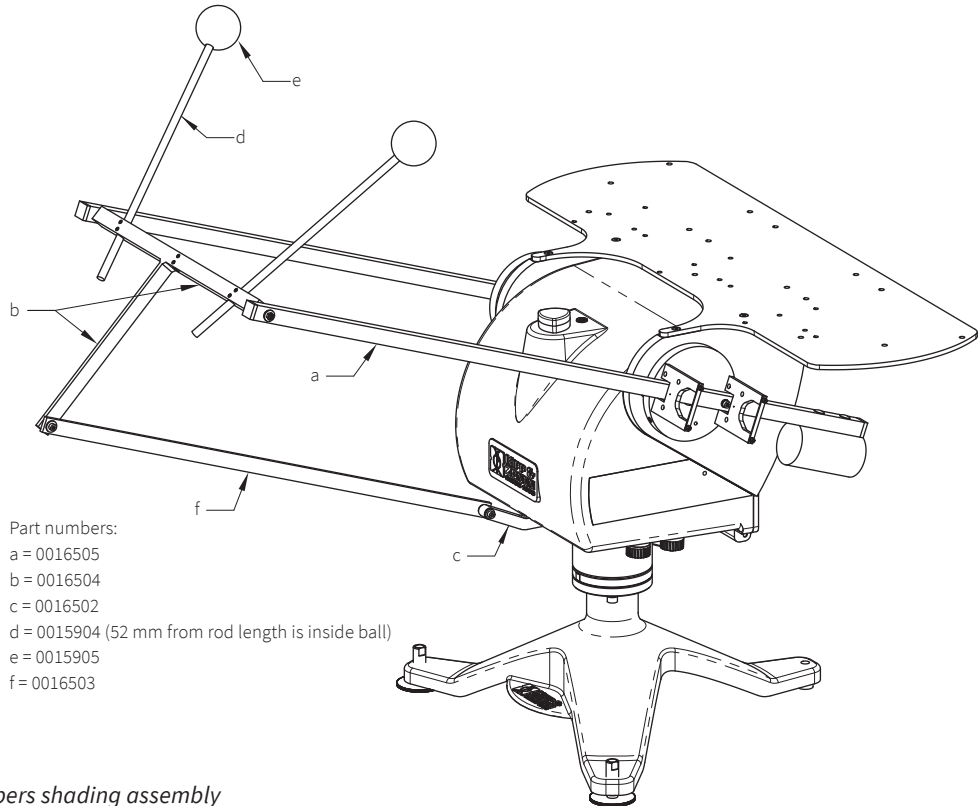

Figure 3.37: Partnumbers shading assembly

3.25.1 Screw kit shading assembly (part number 0367715)

A spare kit is available containing all the screws, rings, washers and tools for the shading assembly. The kit includes the 6 screws to position the shading ball rods. Not including the 3 screws for mounting the SOLYS on the Tripod Floor Stand.

3.25.2 Screw kit for pyr heliometer mounting (part number 0367716)

A spare kit is available containing the screws, washers and small top mounting strip for fixating the Kipp & Zonen pyr heliometers on the side mounting clamps (not including the clamps).

4 Ethernet communication and configuration

This section describes how to communicate with the SOLYS via Ethernet and how to download the LOG files from the SOLYS in case of troubles.

Note Communication with the SOLYS is established via its network interface. However, the SOLYS is not protected by an internal firewall and does not use password encryption. Therefore, the network connected must be secured properly, to avoid hacking of the SOLYS.

The following steps are required to use the Ethernet port for communication with the SOLYS.

Check that all unused connectors on the bottom of the SOLYS have their caps installed during normal operation. The Ethernet connection has a loose gray cap. Both power connections and the sun sensor have attached caps that should be closed when not in use.

4.1 Ethernet connection

1. Download and install Safari for windows from support.apple.com/downloads/safari
2. Remove the plastic plug from the Ethernet connector

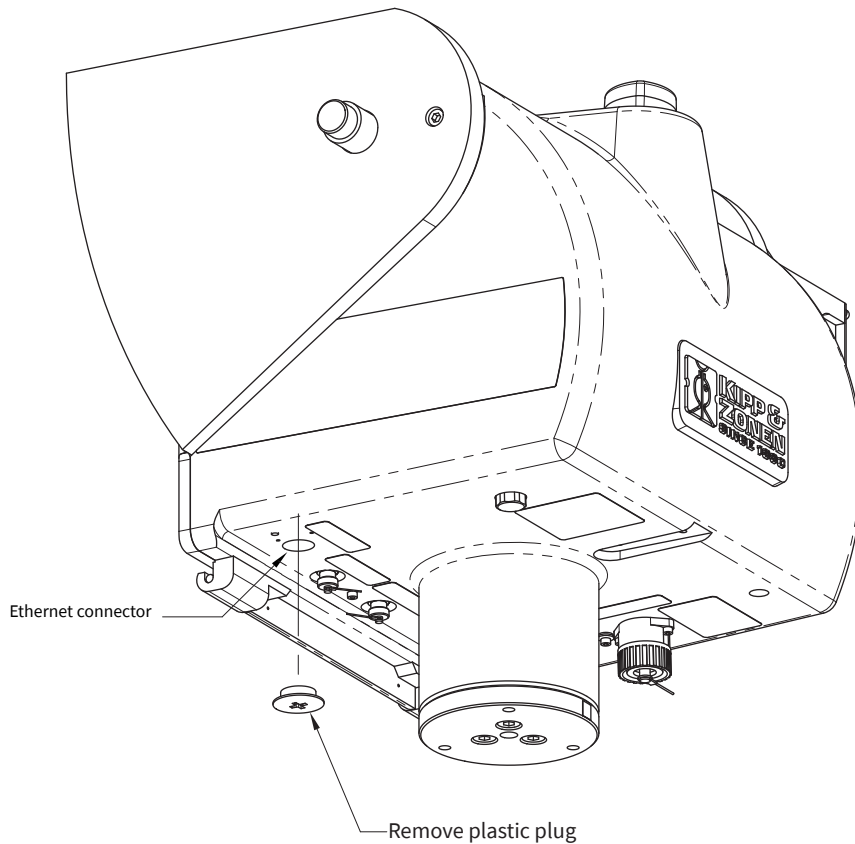

Figure 4.1: Ethernet connector

Recommended cable for Ethernet connection: standard LAN cable, Cat 5e type (4 x 2 x 0.5 mm²; twisted-pair; shielded).
Length: max. 100 m.

Tip The Ethernet interface of SOLYS is equipped with a galvanic isolation to the internal electronics and power supply and with an ESD (Electro-Static-Discharge) protection.

To make the connection waterproof the supplied cable gland for the connector should be fitted to seal the connector against water ingress. The Ethernet connector is fitted with a plastic plug (screw cap) to make it waterproof. If this cap is removed a RJ-45 connector can be fitted.

3. Remove the release clip (and rubber cover) of the Ethernet cable

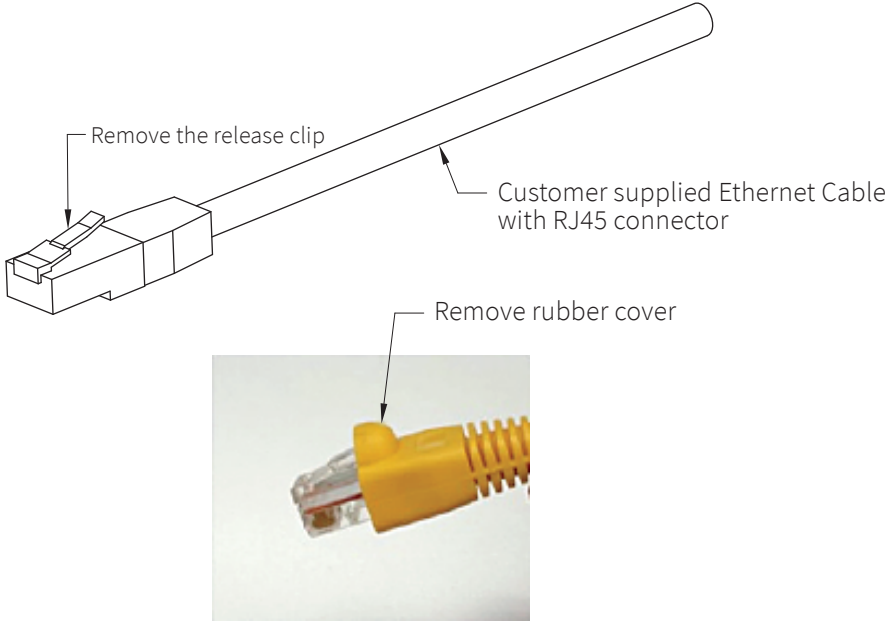

4. Slide cable through cable gland

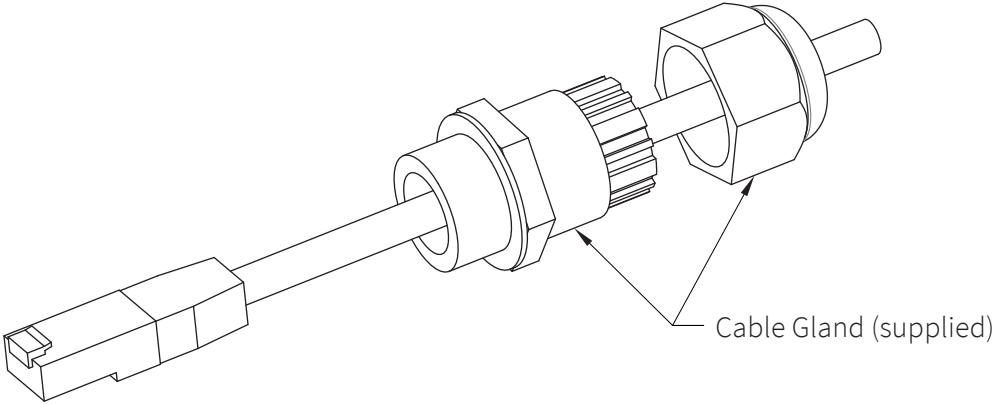

5. Apply self-fusing tape

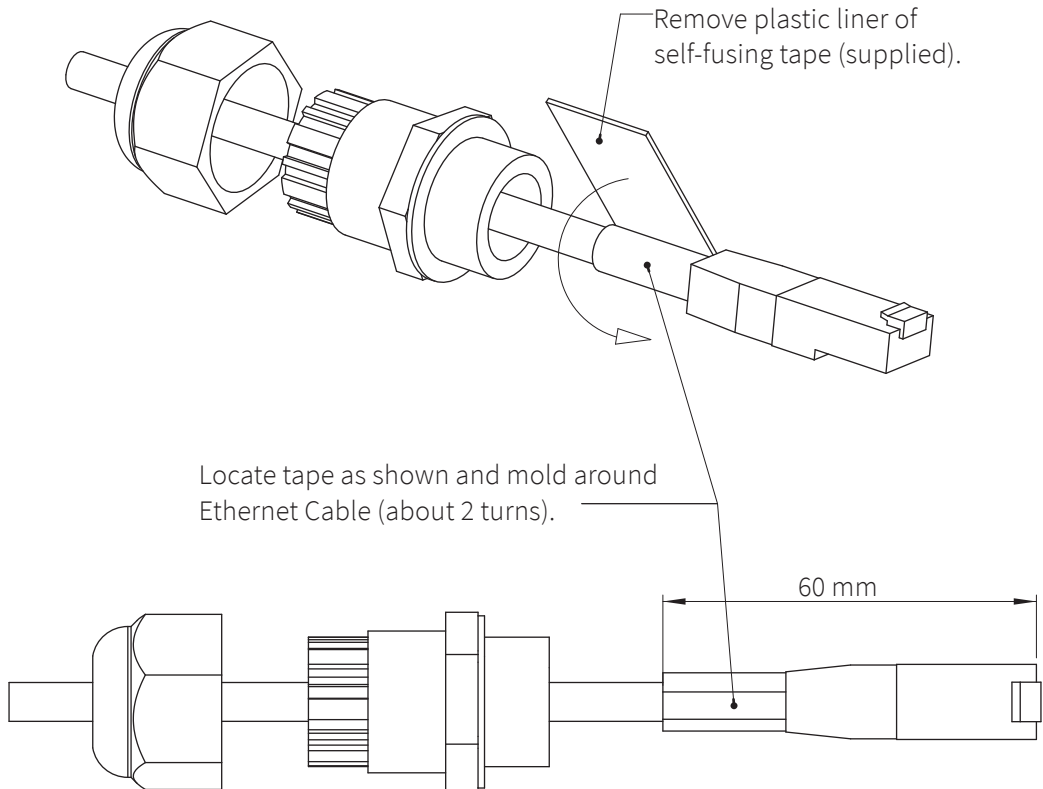

6. Insert the Ethernet cable

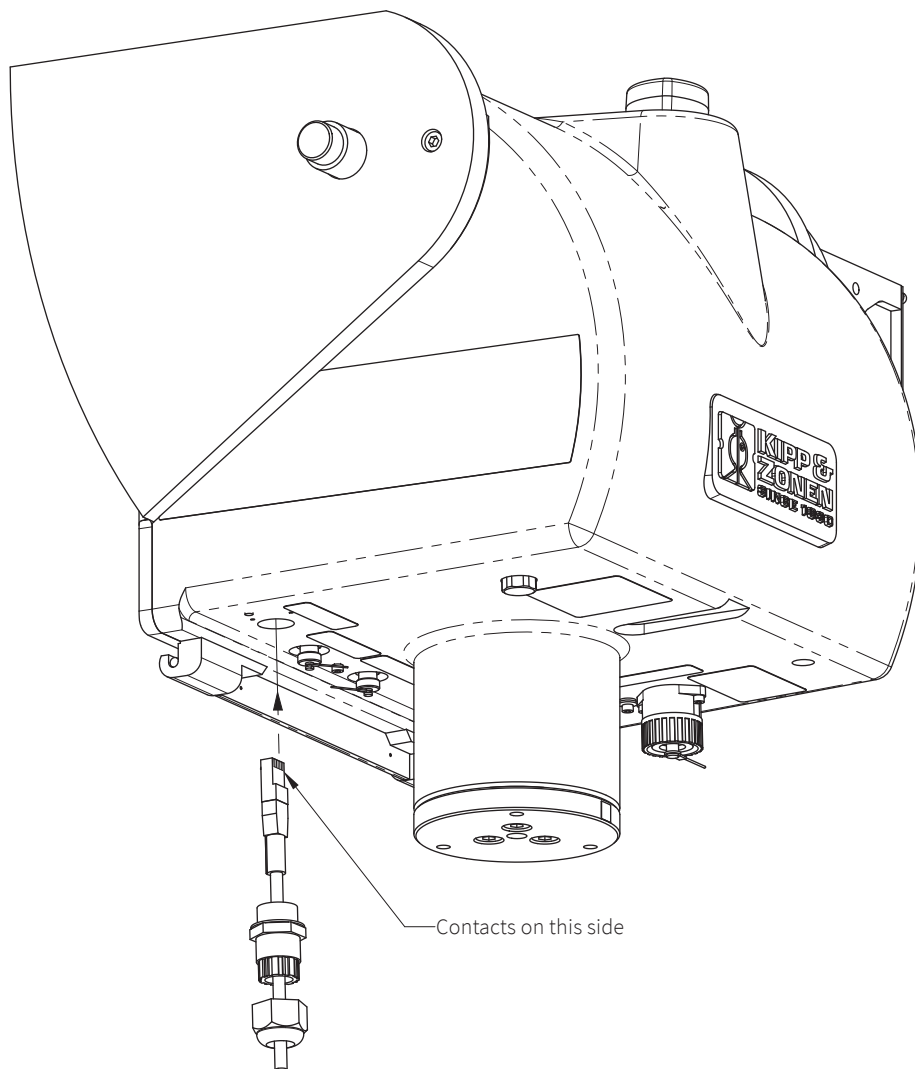

7. Mount the upper part of the Ethernet cable gland.

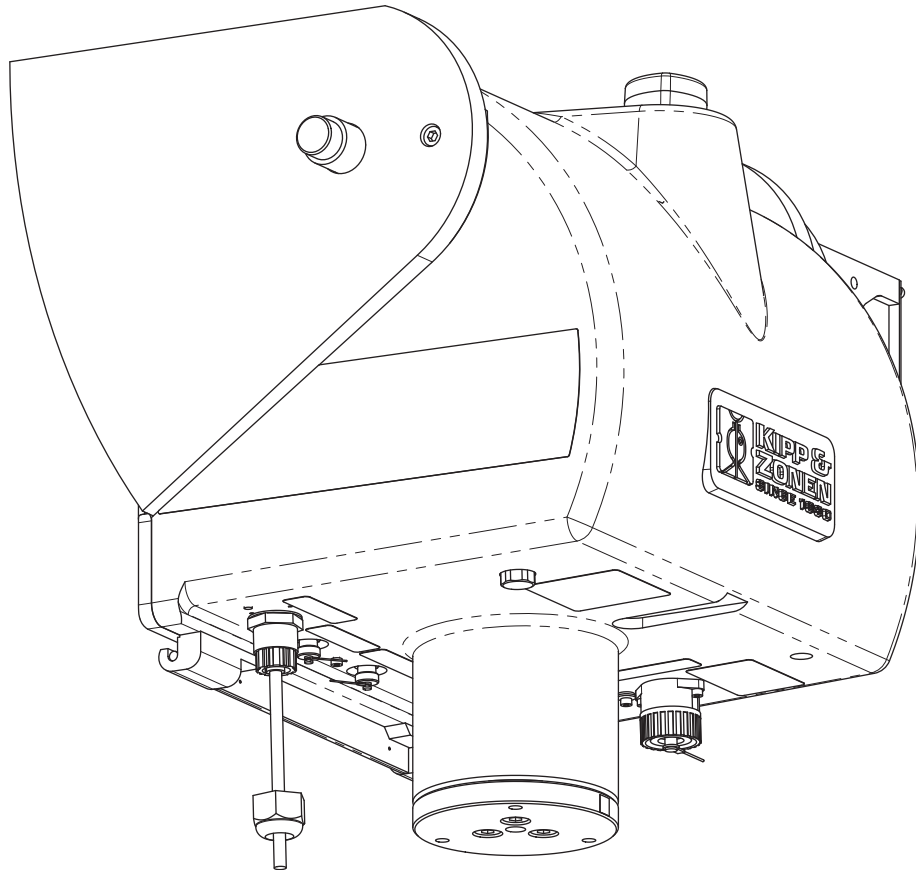

After the Ethernet connector is properly inserted the upper part of the Ethernet cable gland can be screwed in the housing. Push the cable upwards, so the connector remains in place. Please note that only the lower part (nut) of this connector needs to be unscrewed when removing the connector / cable again.

8. Tighten the nut

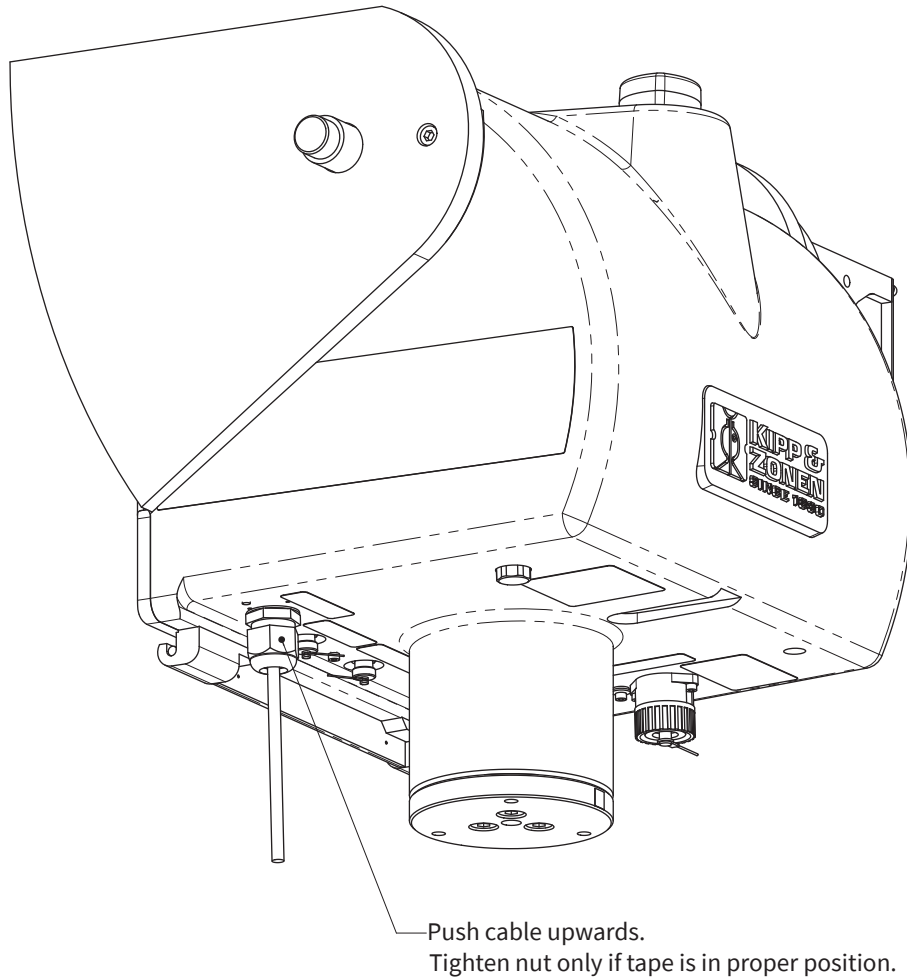

Check if the tape around the cable is still in place, and tighten the nut to make the connection waterproof.

Note Important, communication with the SOLYS is established via its network interface. The Ethernet connection is suitable for permanent use, however, the SOLYS is not protected by an internal firewall. Therefore, the network connected must be secured properly, to avoid hacking of the SOLYS.

4.2 Computer connection

The SOLYS Ethernet connection to your computer can be done in two ways. Choose one of these methods.

- a. Direct connection: connect the SOLYS to the computer with an Ethernet UTP cross-cable. Alternatively a switch may be used to connect both, using 2 straight Ethernet UTP cables.
- b. LAN connection: connect the SOLYS and the computer to the local LAN using straight UTP cables. A DHCP server must be active on the LAN for the SOLYS to be able to obtain an IP address. With the RS-485 connection also a manual setting of the IP address is possible. Check in this case if the selected address fits in your local network range.

4.2.1 SOLYSMonitor

The SOLYS comes with a computer software program called SOLYSMonitor. It allows you to check and log the status and control the communication parameters. Up to 10 SOLYS sun trackers can be connected and monitored.

SOLYSMonitor includes the following functions:

- Finding and connecting a SOLYS on your LAN
- Connecting a SOLYS via RS-485
- Showing the SOLYS instrument parameters on screen
- Showing the Sun Tracking parameters on screen
- Logging the Status information in a file on computer
- Changing the Ethernet communication settings via RS-485
- Starting the SOLYS web interface in your browser

The program can be found on the DVD that comes with the SOLYS and is available on our web site, on the SOLYS sun tracker web page under downloads.

4.2.2 Adding a SOLYS

Add SOLYS System

Remove SOLYS System



By clicking on the 'Add SOLYS System' you get the option to add a SOLYS either Serial (RS-485) or Network (Ethernet) connection. Select the right way your SOLYS is connected.

4.2.3 Adding a SOLYS over RS-485

When the SOLYS tracker is connected via a RS-485 to USB converter to the computer select the assigned COM port for this converter from the pull down menu.

The screenshot shows a dialog box titled "Add SOLYS". At the top, there are two tabs: "Serial" and "Network". The "Serial" tab is highlighted with a red circle. Below the tabs, the "Serial settings" section is visible. It contains five rows of settings, each with a label on the left and a dropdown menu on the right:

Setting	Value
Poort	COM10
Baudrate	19200
Parity	None
Databits	8
Stopbits	One

At the bottom right of the dialog box, there are two buttons: "Cancel" and "Add SOLYS".

The other communication parameters are set correct and are the default values. By clicking the box 'Add SOLYS' this SOLYS will be connected and appear in the next window.

4.2.4 Adding a SOLYS to network

When connecting a SOLYS via Network the program will search (via mDNS) for all available SOLYS's on your network. The SOLYS has to be connected with an Ethernet cable to a LAN socket. When connecting directly to your PC a so called 'cross cable' has to be used.

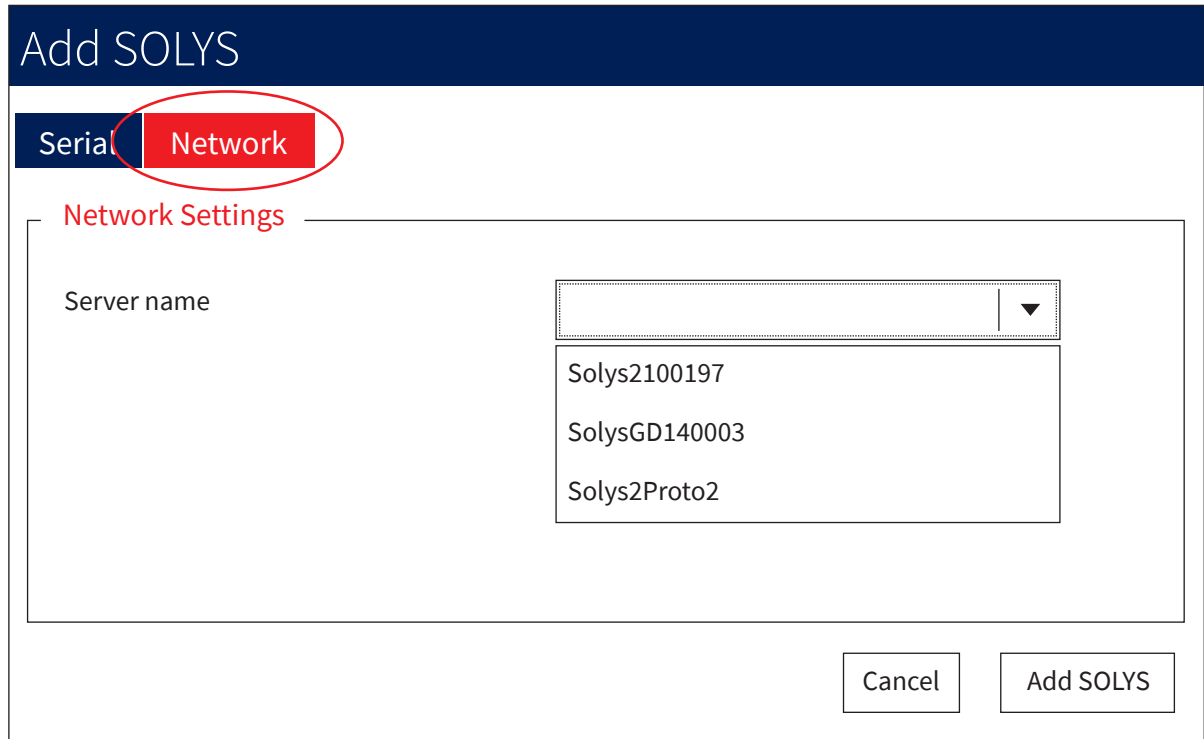



The screenshot shows a software window titled "Add SOLYS" with a dark blue header. Below the header, there are two tabs: "Serial" and "Network". The "Network" tab is selected and highlighted in red, and is also circled in red. Below the tabs, the text "Network Settings" is displayed in red. A "Server name" label is positioned to the left of a text input field. The input field has a pull-down menu icon on its right side. A list of three items is shown below the input field: "Solys2100197", "SolysGD140003", and "Solys2Proto2". At the bottom right of the dialog, there are two buttons: "Cancel" and "Add SOLYS".

By clicking the pull down menu in the selection box the program starts searching on the network for all available SOLYS's. You can click on one of the found SOLYS names or enter its network name or IP address in the selection box.

4.2.5 Tracking status

On the left hand side the connected SOLYS's are shown. Only one is not greyed out and actively monitored on screen. Also the status LED's are visualised (non blinking) as it appears on the SOLYS backplate (for the meaning of the status LED colors see chapter 2.6.5). In total 10 SOLYS's can be monitored and logged at the same time.

Add SOLYS System Remove SOLYS System



SOLYS 2



Tracking Status	Instrument Status	Configuration	Browser
COM10			
SOLYSGD140003			

HostName	SOLYSGD140003
Date	2015/01/07
Time	15:38:33
Suntracking	Using last received GPS latitude, longitude and altitude System clock stratum synchronized Sun sensor intensity < 300 W/m ²
Solar angle azimuth	161.720239
Solar angle zenith	63.070617
Axis angle azimuth	161.697159
Axis angle zenith	63.192314
Latitude	51.996799
Longitude	4.386190
Air pressure	1013.00

4.2.6 Instrument status

The 'Instrument Status' tab (red when active) will give you the status of the monitored SOLYS.

Add SOLYS SystemRemove SOLYS System

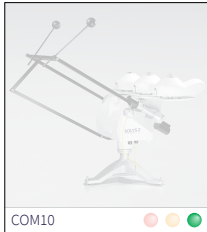

COM10



SOLYSGD140003

Tracking Status	Instrument Status	Configuration	Browser
Suntracking	Using last received GPS latitude, longitude and altitude System clock stratum synchronized Sun sensor intensity < 300 W/m ²		
LED Statuscode	Green-Off		
Instrument flags	Operating autonomously Valid GPS position Valid GPS altitude System time synchronized Fan on Adjustment ok		
Azimuth motor status	Following sun		
Azimuth motor flags	In motion Ref flag set		
Zenith motor status	Following sun		
Zenith motor flags	In motion Ref flag set		

4.2.7 Configuration

The 'Configuration' tab allows you to change the logging location. Select a location that has sufficient space. The default location is: C:\SOLYS\Logging, but can be changed by clicking on the map icon on the right.

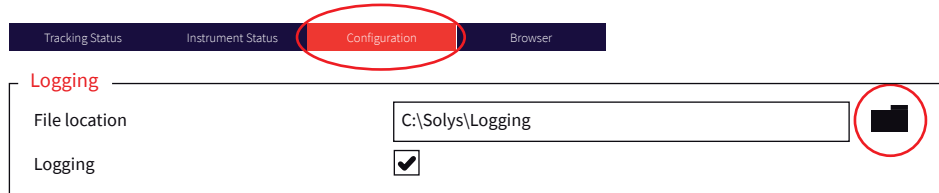

Default logging is on, but can be switched off with the check box. In case multiple SOLYS's are connected a logging file is created for each SOLYS. For Ethernet connection the file name shows the SOLYS name plus date (e.g.: LogInfo_SolysGD140003.26-02-2015.log). For COM port connection the file name shows the COM port plus date (e.g.: LogInfo_COM10.26-02-2015.log).

For both connections this file contains the following information for every second:

2015-02-26 11:29:42,429	computer logging date and time:
- .status=1;	Message type:
SolysGD140003;	SOLYS (network) name:
2015/02/26;	SOLYS, date
10:32:17;	SOLYS, time
156.896621;	Solar Azimuth angle
63.285995;	Solar Zenith angle
156.896652;	SOLYS axis azimuth angle
63.285976;	SOLYS axis zenith angle
51.996799;	Latitude (degrees, North positive)
4.386190;	Longitude (degrees, East positive)
999.40;	Estimated air pressure in millibar, based on altitude
0x012;	Status code
0x0001BA34;	Instrument status
0x210B;	Azimuth motor status
0x210B;	Zenith motor status
0x4F69;	Checksum

See Appendix E.2.3. for detailed explanation of the status codes.

4.2.8 Communication

When a SOLYS is connected via the RS-485 port (via RS-485 to USB connection) an extra tab 'Communication' is available to set communication parameters. This allows you to:

Set and change 'Serial Setting'

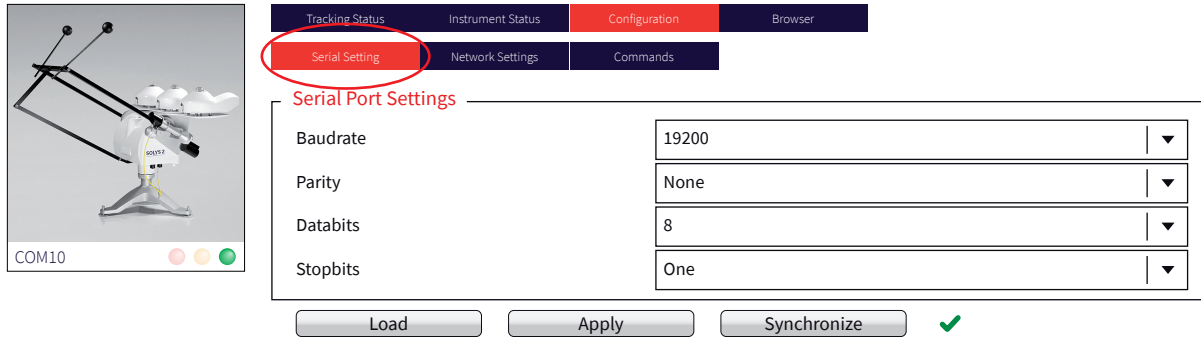

The screenshot shows the SOLYS software interface. On the left is a 3D model of the SOLYS instrument with the label 'COM10' and three status lights (red, yellow, green). The top navigation bar includes 'Tracking Status', 'Instrument Status', 'Configuration', and 'Browser'. Below this, a secondary bar has 'Serial Setting', 'Network Settings', and 'Commands'. The 'Serial Setting' tab is selected and circled in red. The 'Serial Port Settings' panel contains the following fields:

Baudrate	19200
Parity	None
Databits	8
Stopbits	One

At the bottom of the panel are three buttons: 'Load', 'Apply', and 'Synchronize', followed by a green checkmark icon.

Network settings are used to set auto or manual IP address method for network communication. When set to manual, the IP parameters can be entered.

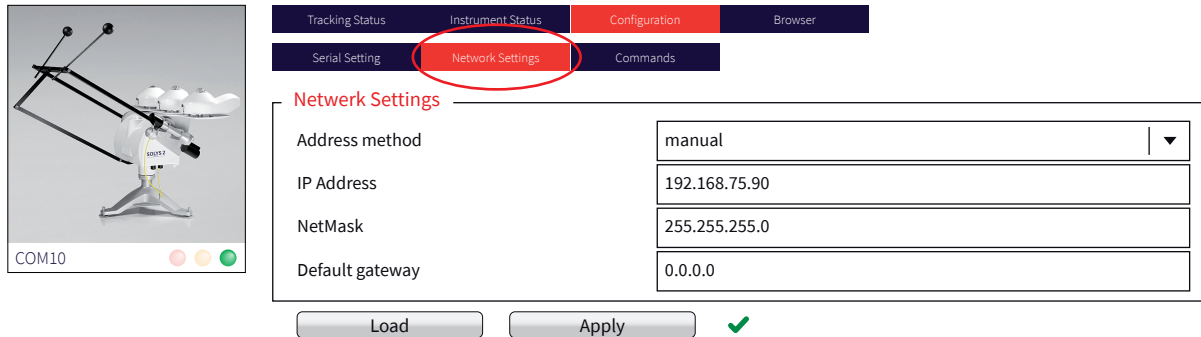

The screenshot shows the SOLYS software interface with the 'Network Settings' tab selected and circled in red. The 'Network Settings' panel contains the following fields:

Address method	manual
IP Address	192.168.75.90
NetMask	255.255.255.0
Default gateway	0.0.0.0

At the bottom of the panel are three buttons: 'Load', 'Apply', and a green checkmark icon.

Finally 'Commands' lets you clear and reset the following parameters:

- Clear Account (revert to defaults)
- Clear IP (Set to default Network parameters, auto IP)
- Clear Serial (Set to default serial parameters)
- Clear Track (reset sun tracking, identical to cold reset)
- Clear All (reset all tracking and communication parameters)
- Serial Break (reset the SOLYS to default comm. Parameters, after 5 seconds switch to stored configuration)
- Reset Track (restart sun tracking)
- Warm Reset (restart the SOLYS)
- Cold Reset (set configuration to default and restart)



Clear Account

Revert user account and operational mode to defaults

Clear Account

4.3 Web interface

The 'Browser' tab will allow you to show the SOLYS web page. When the button 'show' is clicked the SOLYS web page will appear in your default browser.

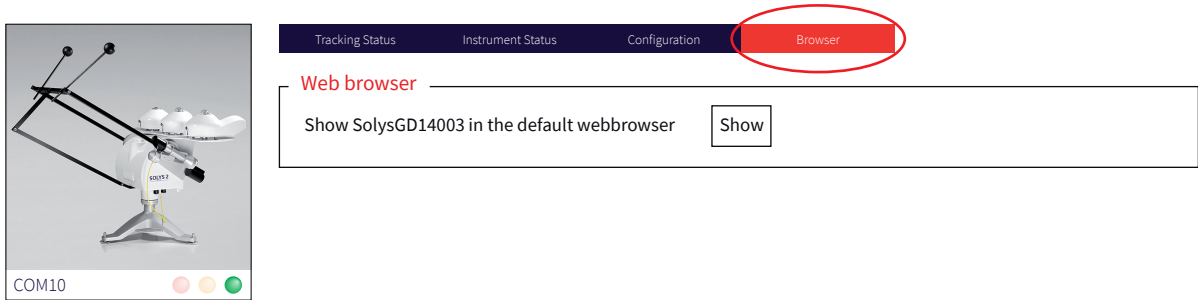

The SOLYS comes up with a window for user name and password. Default settings are, username: user and password: solys



Note that in case of a direct connection, the Windows® computer needs a few minutes to assign itself an Automatic Private IP Address. If it does not, verify that Automatic Private IP Address of the TCP/IP properties of the PC's network connection is enabled.

The status TCP protocol is a subset of the serial communication described in the next chapter

The communication parameters are:

- TCP port 15001
- Number of connections 10

When the server has 10 socket connections and receives a new connection request it will accept the new connection and drop the oldest connection. The oldest connection is determined on base of the 'alive' time. The 'alive' time is initially set to the connection accept time and is updated when any character is received from the HOST.

In order to keep the connection alive at the application level, the HOST may send a character to the server regularly. However, this is not mandatory.

The status TCP interface does not support commands or requests. The description of the messages is identical to the serial protocol. The HOST application must be able to handle disconnection or shutdown of the connection by the server.

The SOLYS communication screen will look like this:

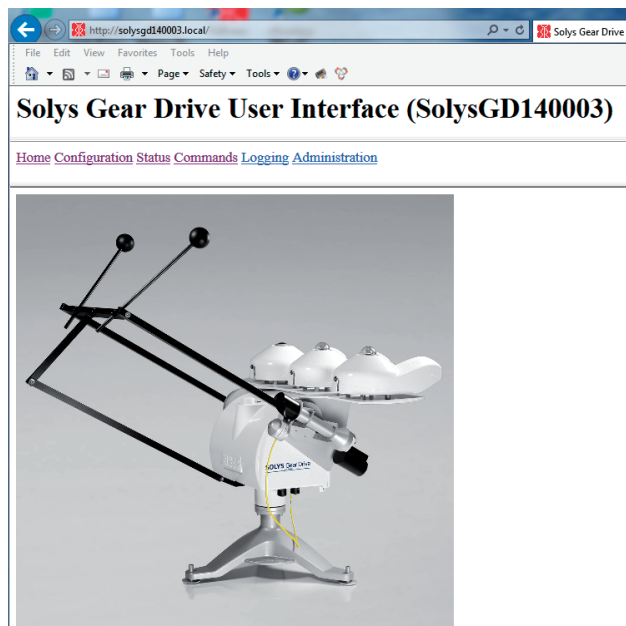

In case of problems with the SOLYS please download the following LOG files.

From the SOLYS User Interface, select 'Logging', and then select the files:

1. Data Archive
2. Sun Log (*.csv.gz.new)
3. Save these file to the computer

Send the saved files to the support department of Kipp & Zonen at support@kippzonen.com for further investigation.

4.4 External commands

The following list of commands is available when connected to the SOLYS. More information is available in the SOLYS user interface (web browser).

- Low level command

This enables to enter any command (two letters) without actually scrolling down the entire list of command (below) to search for the correct one. This is normally used for experienced users. Behind every command in this document we will provide the two letter command that can be entered in the low level command line.

- **Accessory (AC)**

This feature will tell you the presence of any accessory instruments (like a sun sensor).

- **Adjust (AD)**

This will enables to retrieve or set adjustments for the azimuth- and zenith motors.

- **Maximum acceleration (AM)**

This will enables to retrieve or set maximum operating acceleration for the azimuth- and zenith motors.

- **Startup time (BE)**

To retrieve the time at which the most recent session (reset) began.

- **Checkout time (CH)**

With this function you can actually set the SOLYS in sleep mode (and home position) for a desired period.

- **Clear (CL)**

Instantly stops all motors.

- **Cold start (CO)**

Resets the entire configuration to default and will reboot the SOLYS.

- **Current position (CP)**

Retrieves the current positions of all motors.

- Check ref and range (CR)

Sets the check reference and travel range state. 0 is off, 1 is on. Enables waiting in the reference sensors for one minute and moving over the complete travel range. Only executed once after (re)starting tracking. This command is only permitted after protection has been removed with the PWord command.

- Current time and positions (CT)

Retrieves the current time and positions of all motors.

- Error correction (EC)

To retrieve or set the error correction to be enabled (1) or disabled (0).

- Function (FU)

To retrieve or set the actual mode of the SOLYS.

- active tracking mode, tracking the sun using a sun sensor for corrections
- sun tracking mode, tracking the sun & daily time adjustments
- no function, SOLYS will not move
- standard operation mode, positioning mode to manually point the sun tracker to a random point using PO commands
- standard operation (reverse) mode, positioning mode to manually point the sun tracker to a random point using PO commands

- Home (HO)

Tells the SOLYS to go to its home position (ilt will stay there for over 1 minute).

- Checkout at home (HH)

To put the SOLYS in sleep mode after it's returned to its home position.

- Instrument status (IS)

To retrieve the current status (mode) of the SOLYS.

- Lockout GPS altitude (LA)

To retrieve or set enabling of updates to the configuration due to GPS altitude changes (1=updates enabled, 0=updates disabled).

- Location and pressure (LL)

To retrieve or set the latitude, longitude and nominal atmospheric pressure recorded for the site.

- Lockout GPS position (LP)

To retrieve or set enabling of updates to the configuration due to GPS position (longitude, latitude) changes (1=updates enabled, 0=updates disabled).

- Set motor current command (MC)

Set or check the motor current to be <ampère>. This command is only permitted after protection has been removed with the PWord command.

- Move (MO)

Enables to send each motor (as quickly as possible) to its end position.

- Motor Status (MS)

To retrieve the status of each motor (should be successful).

- No hard limits (NL)

To retrieve or set the parameter for enabling the internal pot meters as a security device.

- No soft limits (NX)

To retrieve or set the parameter for enabling the internal Range settings (XT).

- Origin (OR)

To retrieve or set the zero offset from the reference point (East is - 90°).

- Pause (PA)

Enables to pause the actual tracking mode for a specified time (maximum 10 hours).

- Position (PO)

To retrieve or set the final position for all motors.

- Power save (PS)

To retrieve or set the power savings mode (1=enabled, 0=disabled).

- Change protection (PW)

Allows or disallows modification to be done by the web interface to the configuration.

- Change password (PW)

Most of the set commands desire a password which can be changed here.

- Queue status (QS)

To see the actual queue status (every positioning command (PO) is queued).

- Restart sun tracking (RE)

Enables to restart the sun tracking.

- Sun sensor scaling (SC)

To retrieve or set the scaling factor for each sun sensor quadrant along with the nominal scaling of the sensor.

- Serial number (SE)

To retrieve the serial number of the SOLYS.

- Sun intensity (SI)

Retrieves the current sun intensity.

- Sun speed (SP)

To retrieve or set the current sun speed. It is the speed at which the solar algorithm runs.

- Sun sensing parameters (SS)

To retrieve or set the amount of time over which each sun observation takes place and the intensity level below which the sun is deemed to be obscured.

- Steps per revolution (ST)

To retrieve or set, from permanent memory, the number of stepping units in a complete revolution for all motors.

- Synchronize (SY)

To put the SOLYS in sleep mode in the current position after the last segment.

- Time (TI)

To retrieve or set the internal time (Universal).

- Tilt (TL)

To retrieve or set the tilt induced latitude and longitude error of the tracker once it has been levelled.

- Track (TR)

To schedule your own tracking orbit.

- Version (VE)

Just to indicate version information of the I/O board and application.

- Maximum velocity (VM)

To retrieve or set the maximum operating velocity for all motors.

- Warm reset (WA)

Performs a reboot with current configuration.

- Watchdog expire (WD)

Lets the watchdog expire and causes a reboot.

- Where (WH)

To retrieves the end of path information for each specified motor.

- Watermark position (WP)

To retrieve the watermark position of all motors (the watermark position is the most recent position of the motor in which the reference sensor was not activated).

- Range (XT)

To retrieve or set the range for the instrument (azimuth and zenith).

4.5 Serial interface

This chapter describes the serial communication protocol between the SOLYS and the computer or other connected device like server or data logger. The serial communication is based on client-server architecture. The SOLYS is the server, providing the information. The computer is the client, sending commands to or receiving data from the instrument.

The communication protocol has three main roles:

- Sending recovery commands to the SOLYS
- Transmission of the instrument's data (status info) to the computer
- Firmware update
- Instrument hardware configuration

The SOLYS is equipped with a 4-wire RS485 serial interface. The default communication parameters are:

- Baud rate: 19200 bps
- Parity: none
- Data bits: 8
- Stop bits: 1
- Flow control: none

A complete description of the serial communication protocol can be found in the appendix at the end of this manual.

4.6 Interfacing with third party applications

Creating script is possible to retrieve data from the SOLYS via the Ethernet port TCP/IP 15000. The SOLYS sun tracking application has its communication interface on TCP port 15000. Note that it can only handle one connection at a time on this port. In case of a new connection request, the existing socket is disconnected. Note that the web interface of the SOLYS also uses this TCP port to control the sun tracking application. Therefore, do not use the web interface and direct communication to the TCP port at the same time. Also, do not communicate directly with multiple applications to the TCP port. This may lead to unexpected behavior.

4.6.1 Error codes

If an unrecognized command or a command with missing or incorrect parameters is received, the tracker will respond NO followed by one of the following error codes:

- 1 framing error
- 2 reserved for future use
- 3 unrecognized command
- 4 message too long
- 5 unimplemented instruction or non decodable parameters
- 6 motion queue is full, movement command rejected
- 7 travel bounds exceeded
- 8 maximum velocity exceeded
- 9 maximum acceleration exceeded
- A instrument is operating autonomously, command rejected
- B invalid adjustment size
- C invalid total adjustment
- D duration out of range
- E reserved for future use
- F illegal extent specified
- G attempt to change password protected data
- Y hardware failure detected
- Z illegal internal firmware state

5 Maintenance

The SOLYS itself does not need any maintenance. The following things can be checked on visiting intervals:

- Periodically check the condition of all cables and connectors
- Check drying cartridges for mounted radiometers
- Check if bubble level(s) still within range
- Check the pyrhelimeter / sun sensor alignment

The SOLYS itself does not need any re-calibration. However we suggest having the measuring instruments, used on the SOLYS, re-calibrated every two years.

WARNING



Risk of burns due to potentially hot components!

Risk of crushing fingers and hands due to moving mechanical components!

Danger due to electrical voltage!

Inside the SOLYS there are potentially hot, live electrical components that are dangerous to people as well as moving mechanical components!

CAUTION



- > Never open the back plate of the SOLYS!

6 Specifications

6.1 SOLYS Gear Drive specifications

Performance	SOLYS Gear Drive	Comments
Pointing accuracy	< 0.02 °	Active tracking
Torque	> 40 Nm	At 2.5 °/s angular velocity
Torque at sun tracking speed	> 60 Nm	At 0.004 °/s angular velocity
Payload	80 kg	Balanced
Angular velocity	2.5°/s	
Angular acceleration	3.6°/s ²	
Rotation	110° zenith 540° azimuth	
Protection against over rotation/damage	Physical limit stops	

Operating Conditions and Dimensions		
Supply voltage	18 to 30 V _{DC} (nominal 24 V _{DC}) 90 to 264 V _{AC} , 50/60 Hz (nominal 100 to 240 V _{AC})	Auto switching, AC when both connected For world-wide use
Power consumption during Sun cycle	25 W maximum 175 W maximum	DC power AC Power with heater operating
Power consumption after Sun cycle	13 W maximum 163 W maximum	DC power AC Power with heater operating
Maximum operating temperature	+55 °C +60 °C	At 1000 W/m ² without sun shield At 1000 W/m ² with sun shield
Minimum operating temperature	-50 °C -50 °C	AC power without cold cover, wind speed ≤ 1.5 m/s AC power with cold cover, wind speed ≤ 20 m/s
Storage temperature range	-50°C to +60°C	
Weight	26 kg 5 kg 10.5 kg	For standard sun tracker For SOLYS Tripod Floor Stand For Heavy Duty Tripod Floor Stand
Dimensions (w x d x h)	50 x 34 x 38 cm (excluding Tripod Floor Stand)	Includes standard pyrhelioscope mounting
Bubble level accuracy	< 0.1°	Relative to zenith shaft

Compliance to international standards		
Environmental protection	IP 65	Suitable for all-weather outdoor use
CE compliance	Yes	
RoHS compliance	Yes	
Materials	Suitable for coastal use and areas with pollution	

Features		
Transmission	Gear drives	No adjustment or maintenance needed (for 10 years)
Power connections	Socket for AC power, DC power	Plugs for AC and DC supplied
Ethernet interface	RJ-45	DHCP client / Zeroconf Manual network configuration ICMP type 8 and 17 mDNS, UDP port 5353 Web interface, TCP port 80 NTP service, UDP port 123 Track commands, TCP port 15000 Status info, TCP port 15001
RS-485 interface	4 wire isolated, EMI protected Binder 8 pin connector	The interface supports: status info, recovery info and interface configuration
GPS for location and time/date	Standard	Antenna on top of housing
Pyrheliometer mounting	One side plate and mounting kit as standard	For all Kipp & Zonen pyrheliometers
Mounting base	Optional Tripod Floor Stand	Includes adjustable feet for levelling
LED Indicators	Power, internal temperature and status	Multi-color to indicate various modes
Sun sensor kit	For active sun tracking	Plug in unit with alignment adjustment

Customer operation		Comments
Installation	Plug-and-play, no computer required	GPS acquires location and time / date
Functional self test	Standard	Multi-color LED status indicator Cable length test at power on
Test / diagnostic facility	Standard	Via Ethernet port
Sun tracking mode	Standard	Michalsky algorithm (1988)
Computer system requirements	Ethernet connection, web browser, mDNS	Not needed for installation, provides status status and communication parameters
Firmware update possible	Flash memory	Via Ethernet port
Maintenance	No scheduled maintenance required	Annual inspection recommended
Automatic restart after power interruption	Yes	

Options		
Small mounting base	SOLYS Tripod Floor Stand	Includes adjustable feet for levelling
Large mounting base	Heavy Duty Tripod Floor Stand	Includes adjustable feet for levelling Required for height extension tube Advised when not bolted to the floor or with non-balanced loads
Second side mounting plate	For fitting to zenith axis shaft on opposite side to standard pyrheliometer mounting	Does not include instrument mounting brackets
Small top mounting plate	1 position for Kipp & Zonen radiometer (with or without ventilation unit)	No adapters required
Large top mounting plate	3 positions for Kipp & Zonen, Eppley PSP or PIR radiometers (with or without ventilation units)	No adaptors required
Shading ball assembly	Includes large top mounting plate, second side mounting plate, 2 shading balls on adjustable rods	Shading ball height adjustable to suit radiometers above
Extra shading ball and rod	For third position on shading ball assembly	
Extension tube	Can be used in combination with the large mounting base	Extends the height with 60 cm
Sun shield	For extreme hot environments	Up to 60 °C
Cold cover	For extreme cold and windy environments	Down to -50 °C and up to 20 m/s wind speed Needs AC power for heater
Radiometer mounting kits	For Kipp & Zonen pyrheliometers For Kipp & Zonen adjustable tilt mounting kit For Kipp & Zonen CMP/SMP series to the side plate For PMOD-WRC PMO 6 absolute cavity pyrheliometer For Middleton SP02 or SP01-L sun photometer For PGS 100 Sun Photometer For Eppley HF/AHF absolute cavity pyrheliometer For 1 Eppley NIP pyrheliometer, either as a second pyrheliometer or directly to a side plate	All require a side mounting plate

OTT HydroMet reserves the right to make changes to specifications and other product documentation without prior notice

6.2 SOLYS2 specifications

Performance	SOLYS2	Comments
Pointing accuracy	< 0.1 °	Meets BSRN requires requirements
Torque	> 20 Nm	
Payload	20 kg	Balanced
Angular velocity	5°/s	
Angular acceleration	3.6 °/s ²	
Rotation	110 ° zenith 540 ° azimuth	
Protection against over rotation/damage	Physical limit stops	

Operating Conditions and Dimensions		
Supply voltage	18 to 30 V _{DC} (nominal 24 V _{DC}) 90 to 264 V _{AC} , 50/60 Hz (nominal 100 to 240 V _{AC})	Allows for battery charging or under load For world-wide use
Power consumption during Sun cycle	20 W maximum 120 W maximum	DC power AC Power with heater operating
Power consumption after Sun cycle	13 W maximum 113 W maximum	DC power AC Power with heater operating
Operating temperature range	- 20 °C to + 50 °C - 40 °C to + 50 °C	DC Power AC Power (heater standard)
Storage temperature range	-40°C to +50°C	
Weight	23 kg 5 kg	For standard sun tracker For SOLYS Tripod Floor Stand
Dimensions (w x d x h)	50 x 34 x 38 cm (excluding Tripod Floor Stand)	Includes standard pyrheliometer mounting
Bubble level accuracy	< 0.1 °	Relative to zenith shaft

Compliance to international standards		
Environmental protection	IP 65	Suitable for all-weather outdoor use
CE compliance	Yes	
RoHS compliance	Yes	
Materials	Suitable for coastal use and areas with pollution	

Features		
Transmission	Inverted tooth belts	Pre-tensioned, no adjustment needed
Power connections	Plug and socket for AC power, DC power	Male and Female connectors provided
Communication	Ethernet RS-485 interface	Standard waterproof RJ45 connector 4 wire isolated, EMI protected Binder 8 pin connector The interface supports: status info, recovery info and interface configuration
GPS for location and time/date	Standard	Antenna on top of housing
Pyrheliometer mounting	One side plate and mounting kit as standard	For all Kipp & Zonen pyrheliometers
Mounting base	Optional Tripod Floor Stand	Includes adjustable feet for levelling
LED Indicators	Power, internal temperature and status	Multi-color to indicate various modes

Customer operation		
Installation	Plug-and-play, no PC	GPS acquires location and time / date
Functional self test	Standard	Multi-color LED status indicator
Test / diagnostic facility	Standard	Via Ethernet port
Sun tracking mode	Standard	Michalsky algorithm (1988)
Firmware update possible	Flash memory	Via Ethernet port
Maintenance	No scheduled maintenance required	Annual inspection recommended
Auto restart after power interruption	Yes	

Options		
Sun sensor kit	For active sun tracking	Plug in unit with alignment adjustment; 3.12° field of view
Second side mounting plate	For fitting to zenith axis shaft on opposite side to standard Pyrheliometer mounting	Does not include instrument mounting brackets
Top mounting plate	3 positions for Kipp & Zonen radiometers (with or without CVF4 ventilation units) or Eppley PSP / PIR (with or without VEN ventilation units)	No adaptors required
Shading ball assembly	Includes top mounting plate and second side mounting plate & 2 shading balls on adjustable rods	Shading ball height adjustable to suit radiometers above
Radiometer mounting kits	For all Kipp & Zonen pyrheliometers For Kipp & Zonen adjustable tilt CMP/SMP mounting kit For PMOD-WRC PMO 6 absolute cavity pyrheliometer For Middleton SP02 or SP01-L sun photometer For Eppley HF or AHF absolute cavity pyrheliometer For PGS 100 sun photometer For Kipp & Zonen CMP/SMP series to the side plate For 1 Eppley NIP pyrheliometer, either as a second pyrheliometer or directly to a side plate	All require a side mounting plate

6.3 Height specifications SOLYS including instruments

The next illustration displays the actual height of the instruments.

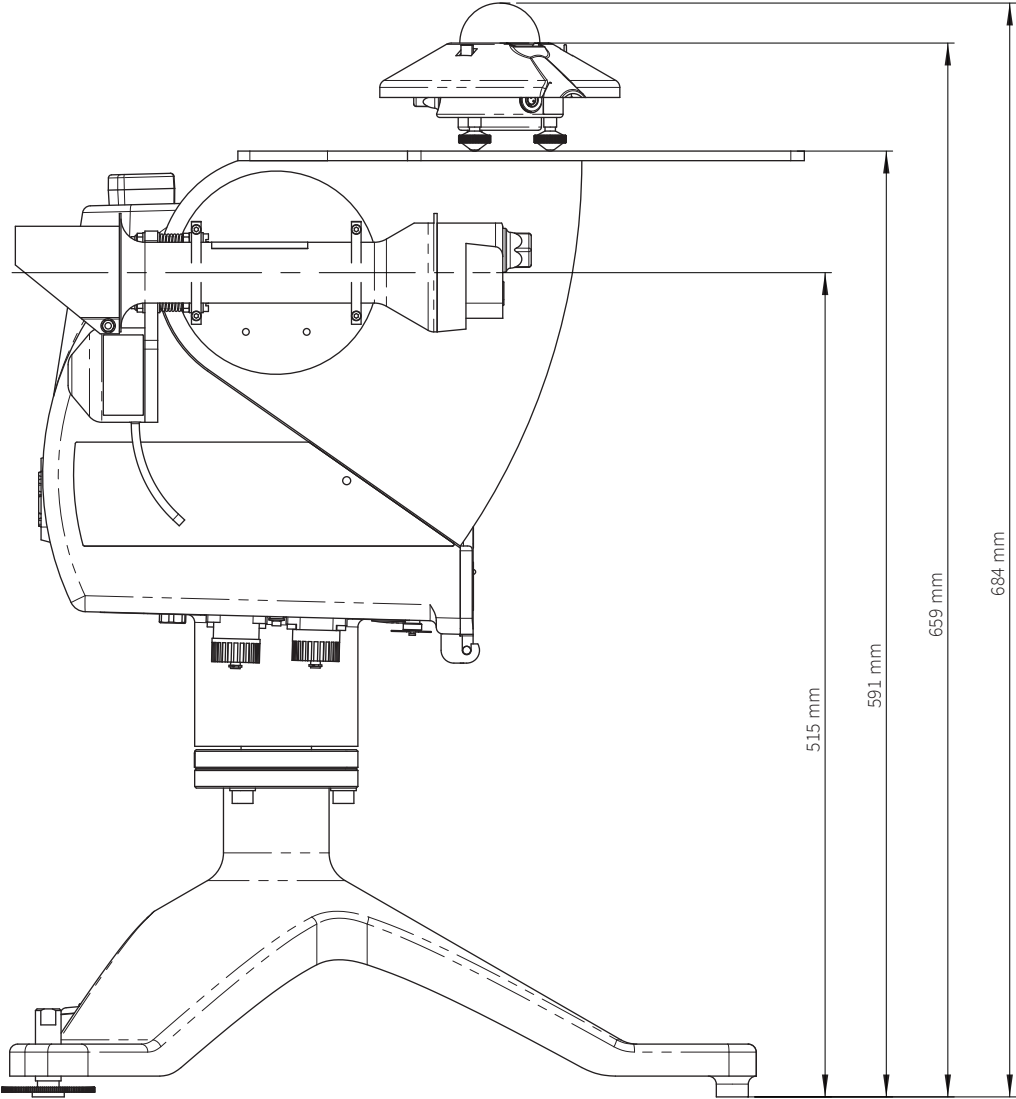



6.4 RS-485 connection

The SOLYS is equipped with a 4 wire RS-485 connection with galvanic isolation to the internal electronics and power supply. All RS-485 wires have an over-voltage protection of 150 V to ground (chassis, V_{DC} ground and V_{AC} protective ground). The RS-485 is ESD and surge protected (IEC 61000-4-2 / 4-5). The serial protocol, commands and messages are described in appendix A to E.

Both the RS-485 and the sun sensor have a 8 pin connector. Identification of the port is on the labels next to the connectors. Exchanging the connectors will not work, but will also not cause any permanent damage.

RS-485 connection

Pin Layout (Sun Tracker)		wire	function	
		8	black	RS-485 / TXD-
		7	white	RS-485 / TXD+
		6	brown	RS-485 / ground
		5	grey	RS-485 / RXD-
		4	yellow	RS-485 / RXD+
		3	green	not connected
		2	blue	not connected
		1	red	not connected
			shield	housing

Recommended cable for RS-485 connection:

cable length	max. 500 m
cable type	shielded low-voltage cable; twisted-pair design
wire cross-section	4 x 2 x 0.5 mm ²

7 Software overview

The software used in the SOLYS contains open source components that are listed in the table below. This software is available from the SOLYS product pages on our website or www.kippzonen.com/Download/847/SOLYS-Labview.

The software and versions listed below were used during the production of this manual. Look on the website for the last revision of this list.

Software	Version	License
Apache	httpd-2.2.8	Apache License 2.0
Avahi	avahi-0.6.17	LGPL 2.1
BusyBox	busybox-1.1.3	GPL 2
Expat XML parser	expat-2.0.0	EXPAT License
GNU C Library	glibc-2.3.3	LGPL 2.1 / Licenses for non-FSF code in GLIBC
GNU Project Debugger	gdb-6.5	GPL 2
GPS Daemon	gpsd-4093 (pre 2.34 + patches)	GPSD License
Grand Unified Bootloader	grub-0.97-33	GPL 2
Ifplugd	ifplugd-0.28	GPL 2
Libdaemon	libdaemon-0.10	LGPL 2.1
Linux Kernel	linux-2.4.31	GPL 2
LinuxThreads Library	glibc-linuxthreads-2.3.3	LGPL 2
Ncurses Library	ncurses-5.5	NCURSES License
Network Time Protocol Daemon	ntp-4.2p3-RC	NTP License
OpenSSL (for configuration data integrity only)	openssl-0.9.8c	OpenSSL License / SSLeay License
PHP	php-5.2.5	PHP 3.01 License
RT-Linux	rtlinux-3.1	OPEN RT LINUX PATENT LICENSE / GPL 2
SOLYS Suntracking Tools	V1R1	Kipp & Zonen SOLYS License
uClibc	uClibc-0.9.28.3	LGPL 2
Vortex86 watchdog driver	vx86wdt	GPL 2
Watchdog Daemon	watchdog-5.4	GPL 1

7.1 Algorithm

The algorithm the SOLYS is using to calculate the sun position is a free to use algorithm developed by J.J. Michalsky. (Working for N.O.A.A.). One of the inputs for this algorithm is time! Six out of ten years the time needs to be corrected due to the earth slowing down. This is what we call the 'leap second'.

The SOLYS has a built in GPS receiver that constantly synchronizes the internal clock with the satellite clock (compensating for drift in the RTC (real time clock) as for the equation of time, the correction is also applied into this algorithm.

8 Firmware

Kipp & Zonen is always looking for implementing improvements by changing the hardware or firmware.

It's advised to check our website on a regular base for the latest version of the firmware. It can easily be upgraded using the network connection available on the SOLYS.

We strongly advise to perform these updates even when your SOLYS seems to operate correct. It can prevent any unwanted situations in the future.

To download the latest firmware update, please check the SOLYS webpage under downloads.

8.1 Firmware upgrade

Step 1/4: Connecting computer

Chapter 4.3 has the appropriate information that explains how to connect a computer/laptop to the SOLYS.

Step 2/4: Download and save the firmware update

Please download the latest firmware from the Kipp & Zonen website.

Save this file (.tar.gz) to any location on your computer.

Step 3/4: Login

Please start the web interface and login to the SOLYS.

See chapter 4.4 for details.

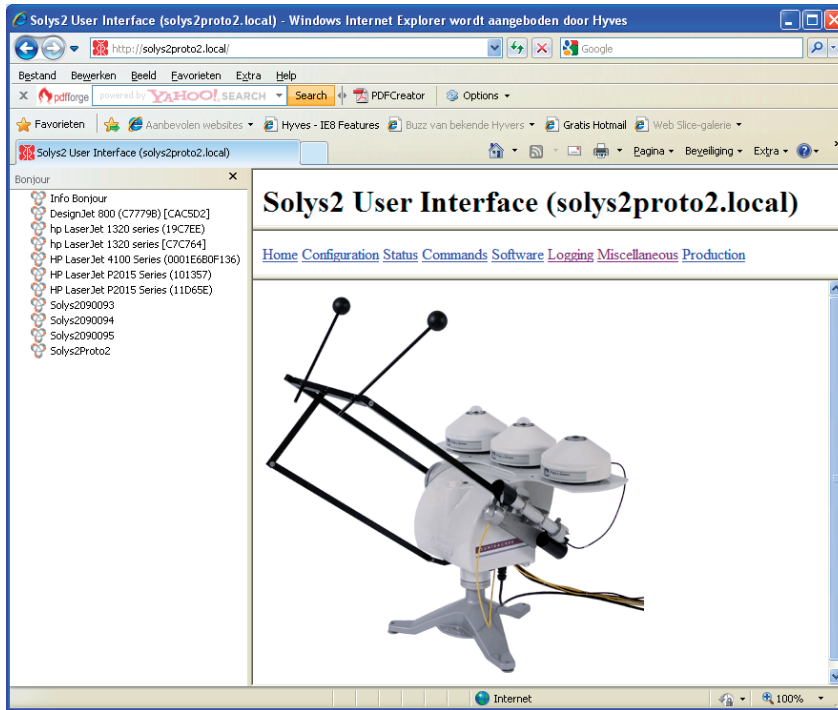

Step 4/4: Update firmware

Note Do not power off the SOLYS while firmware updating!

If the power supply is interrupted during a firmware update, the Solys operating system will not be able to run no longer.

> To perform the firmware update select Administration then select Software Update.

Solys Gear Drive User Interface (SolysGD140003)

[Home](#) [Configuration](#) [Status](#) [Commands](#) [Logging](#) [Administration](#)

Administration

[Password](#)
[Operational Mode](#)
[Network Configuration](#)
[Serial Port Configuration](#)
[Status Interface Configuration](#)

[OS Info](#)
[Timing Daemon Info](#)
[Shared Memory Dump](#)
[GPS Daemon Info](#)
[PHP Info](#)
[Version Info](#)
[Sunta Configuration Dump](#)

[Software Update](#)

Software Update

Select a software update package (*.tar.gz) for upload:

- > Press the 'Browse' button, browse to the software update package file (.tar.gz) and select it.
- > Press the 'Upload' button and wait till the upload is completed. The upload is completed when the message 'Reboot tracker to apply update' appears.
- > Select 'Reboot'. The SOLYS will install the software update package and resume normal operation in a few minutes.
- > To check if the correct firmware is present, select 'Administration' and click on 'version info'.

Solys Gear Drive User Interface (SolysGD140003)

[Home](#) [Configuration](#) [Status](#) [Commands](#) [Logging](#) [Administration](#)

Administration

[Password](#)

[Operational Mode](#)

[Network Configuration](#)

[Serial Port Configuration](#)

[Status Interface Configuration](#)

[OS Info](#)

[Timing Daemon Info](#)

[Shared Memory Dump](#)

[GPS Daemon Info](#)

[PHP Info](#)

[Version Info](#)

[Sunta Configuration Dump](#)

Version Info

SolysLinux V1R4 (Kipp & Zonen B.V., Delft, The Netherlands)

Linux SolysGD140003 2.4.31-rtl-3.1 #1 Mon Feb 9 18:53:27 CEST 2015

BusyBox v1.1.3 (2015.02.09-17:16+0000) multi-call binary

Solys Distribution V2R4 Fri Feb 20 14:38:09 UTC 2015

ifplugd 0.28 (SVN: 124)

udhcpd, version 0.9.9-pre

Server version: Apache/2.2.8 (Unix)

Server built: Feb 9 2015 19:18:54

avahi-daemon 0.6.17

9 Trouble shooting

The SOLYS is designed for long periods of operation with no operator maintenance. However, if a problem occurs that cannot be corrected by using the standard operating information supplied in the preceding sections of this manual, use the information in this chapter to identify and solve the problem.

If the problem cannot be corrected after reviewing the information in the following section, contact Kipp & Zonen. When contacting Kipp & Zonen with technical assistance questions, ensure you have the following information available to aid the technician in solving your problem:

- The serial number of the SOLYS. This information is listed on the serial number label, located on the bottom of the unit
- Mounted options
- Problem description
- Log files (see chapter 4.3)

If you cannot solve the problem by the tips on the next pages, email the problem description to support@kippzonen.com, call us at +31 15 2755 210, or contact the nearest Kipp & Zonen distributor, as listed on our website www.kippzonen.com.

9.1 Problem check-list

Check the items in the following list. If these do not help, see the following section on troubleshooting.

Check that:

- Power is supplied to the unit. Power / Temperature LED should be on and green.

In case the power LED is red and running on AC power, it can take up to 30 minutes before the SOLYS interior is above -20 °C

- In case power LED is red and running on DC power, the SOLYS will only start when environmental temperature gets above -20 °C
- GPS reception is possible; the GPS antenna should not be obstructed by instruments or near by objects (status LED should be green)

9.2 FAQ

Q: The SOLYS does not follow the sun properly, what can be wrong?

A: - Sun sensor connected but not adjusted?
- Check bubble level if the bubble is still in the ring.
- Is alignment target (from pyrhelimeter or mounting clamps) correctly pointing at the sun?

Q: I have a problem with the aligning the SOLYS

A: Proper placement of the SOLYS is important when installing it, as it requires a specific amount of free space to operate.

Make sure the tripod is placed on a solid base. Keep in mind that final alignment is only possible when the sun is shining. The following 8 steps are required to align the SOLYS. In the previous paragraphs additional information is available for each step.

1. Position the tripod with the K&Z logo pointing East.
2. Put the SOLYS on the tripod with the E-marking on the bottom flange pointing East.
3. Put the M8 bolts in by hand but do not tighten them yet.
4. Level the SOLYS by adjusting the tripod feet and checking the bubble level.
5. Connect power to the SOLYS and let it move to its home position.
6. Wait until the green status light is on to indicate the correct GPS position is received.
The SOLYS will now rotate to the sun position.
7. Rotate the SOLYS on its tripod (adjust azimuth) until the alignment target from the pyrhelimeter (or pyrhelimeter bracket) points exactly at the sun.
8. Fasten the 3 x M8 bolts on the tripod
9. The side mounting plate is adjusted in the factory and need no adjustment.
10. If the side mounting plates have been loosened or removed adjust the zenith position as well when the alignment target points at the sun and fasten the screws in the side mounting plates.

Q: Can the SOLYS Gear Drive be moved by hand?

A: Moving the SOLYS Gear Drive by hand, powered or un-powered is not possible. The gear drive inside does not allow this. When the SOLYS has to be moved, azimuth or zenith, this can only be done when power is on. During initialisation (after power on) it will make a full turn both in azimuth (East - West) and in Zenith (up - down) direction for testing the correct cable lengths. If you need the SOLYS to stop at a particular position, just disconnect power on the desired spot.

Q: How to guide the cables and what is the advised cable length.

A: At initial start-up, the SOLYS will make a 540 degree rotation lap. This is checking if the cable length is sufficient. Section 3.24 has a drawing which indicates how to guide the cable.

A Serial Communication

This document describes the serial communication protocol between the instrument and the HOST.

- The SOLYS is referred to as the instrument.
- Data provided by the instrument is collected and processed by the HOST.
- The HOST can be either: a personal computer, an intelligent controller directly connected to the instrument, or a remote server connected to a network.

The serial communication is based on client-server architecture. The instrument is the server, providing the information. The HOST is the client, sending commands to or receiving data from the instrument.

Note: the instrument will regularly send status messages to the host, so the host is kept up to date regarding the current status of the instrument. The interval of the status messages is 1 second.

The communication protocol has two main roles:

1. Sending recovery commands to the instrument.
2. Transmission of the instrument's data (status info) to the HOST.

A.1 Firmware release

This document is valid for the SOLYS firmware release V2R4 and up. In case a higher firmware release supports a changed version of the serial protocol, a new version of this document will describe the new protocol and state the differences.

A.2 Instrument hardware configuration

The instrument is equipped with a 4-wire RS-485 serial interface.

B The protocol layer

B.1 Communication parameters

B.1.1 Default communication parameters

The default communication parameters are:

- Baud rate: 19200 bps
- Parity: none
- Data bits: 8
- Stop bits: 1
- Flow control: none

When the server receives a serial break signal, it will switch to default communication parameters. After 5 seconds of inactivity of the HOST, it will switch back to the configured communication parameters. This feature ensures the HOST can always gain access to the instrument.

B.1.2 Miscellaneous

Command, request and response lines are terminated by a linefeed <LF>. Carriage returns <CR> are discarded in commands and requests.

B.2 Client server protocol

The instrument provides the information and will send a response on every command from the HOST. Every request from the HOST is acknowledged by 0, 1 or more responses and a prompt. See examples 1 to 3. The instruments transmit a status message periodically. A status message should not be acknowledged by the HOST (see example 4).

Direction	Client (host)		Server (instrument)		
Example 1	Action host	Request	Response	Action instrument	
→	Transmit request	Request		Process request	
←			Prompt	Acknowledge	
Example 2					
→	Transmit request	Request		Process request	
←			Response	Send response	
←			Prompt	Acknowledge	
Example 3					
→	Transmit request	Request		Process request	
←			Response1	Send response 1 to 3	
←			Response2		
←			Response3		
←			Prompt	Acknowledge	
Example 4					
←			Status	Send status	

C The application protocol

- Presentation: All data transfers will use 7 bit or 8 bit printable ASCII code.
- Application: The application protocol is a set of commands and responses.

C.1 Command structure

Commands, also referred as requests, are sent from the HOST to the instrument. After each request a response is sent by the instrument. Commands are processed after receiving the linefeed. Carriage returns are discarded. Commands are case sensitive. Commands must start with a dot '.'. Optional parameters are separated by spaces or semicolons. The instrument will send the '.OK;' prompt, after every command or response.

General structure of a command:

```
<dot>command{<space>subcommand1{;subcommand2{...}}};<LF>
```

or

```
<dot>command{<space>param1=value1{;param2=value2{...}}};<LF>
```

Optional parameters and subcommands are placed between parenthesis '{ ... }'.

Examples:

Request .reset track;<LF>

Response .ok;<LF>

Request .rest track;<LF>

Response .error='command .rest not supported';<LF>

Response .ok;<LF>

Request .reset ip0;ser0;<LF>

Response .ok;<LF>

Request .set ip0address=10.1.2.3;<LF>

Response .ok;<LF>

```
Request      .set ip0address=10.1.2.3;ip0netmask=255.255.255.0;ip0gateway=10.1.2.1;<LF>
Response     .ok;<LF>

Request      .show ip0method;ip0address;ip0netmask;ip0gateway;<LF>
Response     .ip0method=auto;<LF>
Response     .ip0address=192.168.75.90;<LF>
Response     .ip0netmask=255.255.255.0;<LF>
Response     .ip0gateway=192.168.75.1;<LF>
Response     .ok;<LF>
```

Requests are sent by the HOST to the instrument. Responses are sent by the instrument to the HOST after processing the request.

C.2 Overview

C.2.1 Overview commands

The following commands are used to manipulate configuration parameters and reset (a function of) the instrument.

COMMANDS	CHAPTER	DESCRIPTION
.set	C.2.2	Set parameter
.show	C.2.3	Show parameter
.clear	C.2.4	Clear parameter
.reset	C.2.5	Reset (a function of) the instrument

C.2.2 Overview command: 'set' parameter

The following commands are used to set configuration parameters. Configuration parameters will keep their value after a power cycle.

COMMAND : SET	CHAPTER	DESCRIPTION
.set opermode	D.1.1	Set the instrument operational mode
.set ip0method	D.3.1	Set the IP address method
.set ip0address	D.3.3	Set the IP address
.set ip0netmask	D.3.5	Set the IP netmask
.set ip0gateway	D.3.7	Set the IP gateway
.set ser0baudrate	D.4.1	Set the serial interface baudrate
.set ser0parity	D.4.3	Set the serial interface parity
.set ser0databits	D.4.5	Set the serial interface number of databits
.set ser0stopbits	D.4.7	Set the serial interface number of stopbits

C.2.3 Overview command: 'show' parameter

The following commands are used to show configuration parameters.

COMMAND : SHOW	CHAPTER	DESCRIPTION
.show opermode	D.1.2	Show the instrument operational mode
.show hostname	D.2.1	Show the instrument hostname
.show ip0method	D.3.2	Show the IP address method
.show ip0address	D.3.4	Show the IP address
.show ip0netmask	D.3.6	Show the IP netmask
.show ip0gateway	D.3.8	Show the IP gateway
.show ser0baudrate	D.4.2	Show the serial interface baudrate
.show ser0parity	D.4.4	Show the serial interface parity
.show ser0databits	D.4.6	Show the serial interface number of databits
.show ser0stopbits	D.4.8	Show the serial interface number of stopbits

C.2.4 Overview command: 'clear' parameter

The following commands are used to clear the configuration of the instrument.

COMMAND : CLEAR	CHAPTER	DESCRIPTION
.clear account	D.1.3	Revert user account and operational mode to defaults
.clear ip0	D.3.9	Revert the IP configuration to defaults
.clear ser0	D.4.9	Revert the serial interface configuration to defaults
.clear track	D.5.1	Revert the suntracking configuration to defaults
.clear all	D.5.2	Issue clear account, ip0, ser0 and track

C.2.5 Overview command: 'reset' parameter

The following commands are used reset (a function of) the instrument.

COMMAND: RESET	CHAPTER	DESCRIPTION
.reset track	D.6.1	Restart the suntracking process
.reset warm	D.6.2	Restart the instrument
.reset cold	D.6.3	Revert the suntracking configuration to defaults and restart the instrument

D Description of the commands

This chapter describes the commands listed in the overview of chapter C.2.

D.1 Instrument operational mode

The instrument should be put in maintenance mode while assembling or servicing the instrument. In maintenance mode the instrument allows assembly and service activities and authenticates against fixed pre-set passwords.

The normal mode should be set when not assembling or servicing the instrument. The normal mode passwords will be kept in maintenance mode and will be reactivated after switching back to normal mode.

D.1.1 Set instrument operational mode

Description

The command: `‘.set opermode=<mode>’` will set the instrument operational mode.

Argument (1)

Description The instrument operational mode.

Type Text string

Range ‘normal’, ‘maintenance’

Default ‘normal’

Example

Request:

```
.set opermode=maintenance;
```

Response:

```
.ok;
```

D.1.2 Show instrument operational mode

Description

The command: `‘.show opermode;’` will show the instrument operational mode.

Argument (none)

Example

Request:

```
.show opermode;
```

Response:

```
.ok;
```

D.1.3 Clear user account (and operational mode)

Description

The command: `‘.clear account;’` will revert the user account passwords and operational mode to defaults. The command may be used to go to a known state when logging in on one if the instrument interfaces fails.

D.2 Hostname

D.2.1 Show hostname

Description

The command: `‘.show hostname;’` will show the network hostname of the instrument. The hostname is a text string consisting of the instrument type and a 6-character serial number: `‘<type><serial>’`

Arguments (none)

Example

Request:

```
.show hostname;
```

Response:

```
.hostname=SolysGD140001; .ok;
```

D.3 Network configuration

The instrument’s IPv4 configuration can be showed, set and cleared via the serial interface. It serves as a last resort in case the operator is locked out. Under normal circumstances the IPv4 configuration should be done using the web interface.

D.3.1 Set IP address method

Description

The command: `‘.set ip0method=<method>;’` will set the IP address method. When the auto method is selected, the manually configured IP address, netmask and gateway remain stored and can be reactivated by selecting the manual method.

Argument (1)

Description	IP address method
Type	text string
Range	‘manual’, ‘auto’
Default	‘auto’

Example

Request:

```
.set ip0method=manual;
```

Response:

```
.ok;
```

D.3.2 Show IP address method

Description

The command: `.show ip0method;` will show the configured IP address method.

Argument (none)

Example

Request

```
.show ip0method;
```

Response

```
.ip0method=auto;  
.ok
```

D.3.3 Set IP address

Description

The command: `.set ip0address=<address>;` will set the IP address.

Argument (1)

Description	IP address
Type	4-octet text string
Range	'0.0.0.0' to '255.255.255.255'
Default	'192.168.75.90'

Example

Request:

```
.set ip0netmask=10.1.2.100;
```

Response:

```
.ok;
```

D.3.4 Show IP address

Description

The command '.show address' will show the configured IP address.

Argument (none)

Example

Request

```
.show ip0address;
```

Response

```
.ip0address=10.1.2.100;  
.ok
```

D.3.5 Set IP netmask

Description

The command: '.set ip0netmask=<netmask>,' will set the IP netmask.

Argument (1)

Description	IP netmask
Type	4-octet text string
Range	'0.0.0.0' to '255.255.255.255'
Default	'255.255.255.0'

Example

Request:

```
.set ip0netmask=255.255.255.0;
```

Response:

```
.ok;
```

D.3.6 Show IP netmask

Description

The command `‘.show ip0netmask’` will show the configured IP netmask.

Argument (none)

Example

Request

```
.show ip0netmask;
```

Response

```
.ip0netmask=255.255.255.0;  
.ok
```

D.3.7 Set IP gateway

Description

The command: `‘.set ip0gateway=<gateway>’` will set the IP gateway.

Argument (1)

Description	IP gateway
Type	4-octet text string
Range	‘0.0.0.0’ to ‘255.255.255.255’
Default	‘255.255.255.0’

Example

Request:

```
.set ip0gateway=255.255.255.0;
```

Response:

```
.ok;
```

D.3.8 Show IP gateway

Description

The command '.show ip0gateway' will show the configured IP gateway.

Argument (none)

Example

Request

```
.show ip0gateway;
```

Response

```
.ip0gateway=255.255.255.0;  
.ok
```

D.3.9 Clear IP configuration

Description

The command '.clear ip0;' will revert the IP configuration parameters to defaults.

Argument (none)

Example

Request

```
.clear ip0;
```

Response

```
.ok
```

D.4 Serial interface configuration

Serial interface configuration command responses are sent before the configuration is changed. The actual change of configuration happens a few seconds later, possibly while sending a status message.

D.4.1 Set serial interface baud rate

Description

The command: `‘.set ser0baudrate=<rate>;’` will set the baud rate.

Argument (1)

Description	baud rate
Type	integer
Range	4800, 9600, 19200, 38400, 57600, 115200
Default value	19200

Example

Request:

```
.set ser0baudrate=115200;
```

Response:

```
.ok;
```

D.4.2 Show serial interface baud rate

Description

The command: `‘.show ser0baudrate;’` will show the configured baud rate.

Argument (none)

Example

Request:

```
.show ser0baudrate;
```

Response:

```
.ser0baudrate=115200;
```

```
.ok;
```

D.4.3 Set serial interface parity

Description

The command: '.set ser0parity=<parity>,' will set the parity.

Argument (1)

Description	parity
Type	string
Range	none, odd, even
Default value	none

Example

Request:

```
.set ser0parity=odd;
```

Response:

```
.ok;
```

D.4.4 Show serial interface parity

Description

The command: '.show ser0parity,' will show the configured parity.

Argument (none)

Example

Request:

```
.show ser0parity;
```

Response:

```
.ser0parity=even;
```

```
.ok;
```

D.4.5 Set serial interface number of data bits

Description

The command: `‘.set ser0databits=<bits>’` will set the number of data bits.

Argument (1)

Description	number of data bits
Type	integer
Range	7 or 8
Default value	8

Example

Request:

```
.set ser0databits=7;
```

Response:

```
.ok;
```

D.4.6 Show serial interface number of data bits

Description

The command: `‘.show ser0databits;’` will show the configured number of data bits.

Argument (none)

Example

Request:

```
.show ser0databits;
```

Response:

```
.ser0databits=8;
```

```
.ok;
```

D.4.7 Set serial interface number of stop bits

Description

The command: `‘.set ser0stopbits=<bits>’` will set the number of stop bits.

Argument (1)

Description	number of stop bits
Type	integer
Range	1 or 2
Default value	1

Example

Request:

```
.set ser0stopbits=2;
```

Response:

```
.ok;
```

D.4.8 Show serial interface number of stop bits

Description

The command: `‘.show ser0stopbits;’` will show the configured number of stopbits.

Argument (none)

Example

Request:

```
.show ser0stopbits;
```

Response:

```
.ser0stopbits=1;  
.ok;
```

D.4.9 Clear serial interface configuration

Description

The command `‘.clear ser0;’` will revert the serial interface configuration parameters to defaults.

Argument (none)

Example

Request

```
.clear ser0;
```

Response

```
.ok;
```

D.5 Miscellaneous commands

D.5.1 Clear suntracking configuration

Description

The command `‘.clear track;’` will revert all suntracking configuration parameters to defaults. The instrument will reset as a result of this command. This command has the same effect as the `‘.reset cold’` command, see paragraph 0.

Argument (none)

Example

Request

```
.clear track;
```

Response

```
.ok;
```

D.5.2 Clear all configuration

Description

The command `‘.clear all;’` will revert user account, operational mode, network configuration, serial interface configuration and suntracking configuration to defaults. The instrument will reset as a result of this command. The command combines `‘.clear account;ip0;ser0;track;’`.

Argument (none)

Example

Request

```
.clear all;
```

Response

```
.ok;
```

D.6 Reset commands

Reset commands restart the suntracking process (track), the instrument (warm) or clear suntracking parameters and restart the instrument (cold).

D.6.1 Suntracking reset

Description

The command `.reset track;` will restart the suntracking process while the instrument's internal computer keeps running.

Argument (none)

Example

Request

```
.reset track;
```

Response

```
.ok;
```

D.6.2 Warm reset

Description

The command `.reset warm;` will restart the instrument.

Argument (none)

Example

Request

```
.reset warm;
```

Response

```
.ok;
```

D.6.3 Cold reset

Description

The command `.reset cold;` will revert all suntracking configuration parameters to defaults and restart the instrument. This command has the same effect as the `.clear track` command, see paragraph D.5.1.

Argument (none)

Example

Request

```
.reset cold;
```

Response

```
.ok;
```

E Description of the messages

This chapter describes the definition of the status messages. Each different record type has a unique record ID to specify the selected type.

E.1 Message types

The following message types are defined:

Message type

- 0 Simple status message
- 1 Extended status message
- 2+ Reserved for future expansion

E.2 Status messages

The status messages are sent automatically every second. There are 2 formats available, a simple format and an extended format.

E.2.1 Simple status message

Description

Pos	Field name	Description
0	Message type	0
1	Hostname	Instrument hostname
2	Date	Current date, YYYY/MM/DD
3	Time	Current time, HH:MM:SS
4	Solar angle azimuth	Calculated solar angles in degrees North 0 degrees, east 90 degrees
5	Solar angle zenith	Sky 0 degrees, horizon 90 degrees
6	Status code	Status code, 3 hexadecimal nibbles. See paragraph E.2.3
7	Checksum	CRC-16 reverse bit order with seed of 0 and XOR polynomial of 0xA001. The checksum is calculated over all characters till (not including) the first character of the checksum. The value is in hexadecimal notation (0x<hex>).

Example

Response

```
.status=0;SolysGDSom001;2014/10/28;14:26:24;-134.747698;75.851923;0x044;0x6648;<LF>
```

E.2.2 Extended status message

Description

Message Type 1		Extended status message
Pos	Field name	Description
0	Message type	1
1	Hostname	Instrument hostname
2	Date	Current date, YYYY/MM/DD
3	Time	Current time, HH:MM:SS
4	Solar angle azimuth	Calculated solar azimuth/zenith angles in degrees. North 0 degrees, east 90 degrees.
5	Solar angle zenith	Sky 0 degrees, horizon 90 degrees.
6	Axis angle azimuth	Actual azimuth/zenith axis angles in degrees. North 0 degrees, east 90 degrees.
7	Axis angle zenith	Sky 0 degrees, horizon 90 degrees.
8	Latitude	Latitude in degrees. North positive, south negative.
9	Longitude	Longitude in degrees. East positive, west negative.
10	Air pressure	Estimated air pressure in millibar. The estimation is based on the altitude, ground level of 1013 millibar and atmospheric scale height of 7400 meters.
11	Status code	Status code. See paragraph E.2.3
12	Instrument status	Instrument status. See paragraph E.2.4
13	Azimuth motor status	Motor status. See paragraph E.2.5
14	Zenith motor status	
15	Checksum	CRC-16 reverse bit order with seed of 0 and XOR polynomial of 0xA001. The checksum is calculated over all characters till (not including) the first character of the checksum. The value is in hexadecimal notation (0x<hex>).

Example

Response

```
.status=1;SolysGD140001;2014/10/28;14:26:24;-134.747698;75.851923;225.252365;75.851952;  
51.996899;4.386230;999.36;0x044;0x00018234;0x210B;0x210B;0x6648;<LF>
```

E.2.3 Status code

The status code reflects the visual indication of the status led on the instrument's rear plate. The led has 4 states (red, green, orange and off). The instrument has a circular buffer with 3 elements, each element holds a led state or may be set to unused. Each element of the circular buffer is displayed by the led for 1 second. In case an element is set to unused, the buffer readout will proceed from the start without delay. This allows for 1, 2 and 3 second led sequences.

The status code consists of 3 nibbles. The values of the nibbles correspond to the instrument's circular buffer. The least significant nibble is displayed first.

Led state	Nibble value
UNUSED	0
OFF	1
GREEN	2
RED	3
ORANGE	4

Status	Status LED Color (1 second per color)	Status Code
Hardware error	Red	0x003
Initializing (until found reference position)	Red-Off	0x013
Initialized (found reference position)	3x Green-Orange-Red	N/A
Check references and range (1 minute in reference position and orientation lap)	Green-Orange-Red	0x342
Positioning	Orange	0x004
• moving to position		
Positioning	Green	0x002
• reached position		
Suntracking	Orange-Orange	0x044
• using stored latitude, longitude and annual mean pressure		
Suntracking	Orange-Orange-Off	0x144
• using stored latitude, longitude and annual mean pressure		
• power save active		
Suntracking	Green-Orange	0x042
• using last received GPS latitude, longitude and altitude		
• system clock stratum > 3		
Suntracking	Green-Orange-Off	0x142
• using last received GPS latitude, longitude and altitude		
• system clock stratum > 3		
• power save active		
Suntracking	Green-Green	0x022
• using last received GPS latitude, longitude and altitude		
• system clock stratum ≤ 3		
• no sunsensor		
Suntracking	Green-Green-Off	0x122
• using last received GPS latitude, longitude and altitude		
• system clock stratum ≤ 3		
• no sunsensor		
• power save active		
Suntracking	Green-Red	0x032
• using last received GPS latitude, longitude and altitude		
• system clock stratum ≤ 3		
• observed adjustment > sunsensor halfscale (1.123°) or axis adjustment > 95% of maximum (95% of 4°)		
Suntracking	Green-Off	0x012
• using last received GPS latitude, longitude and altitude		
• system clock stratum ≤ 3		
• sunsensor intensity < 300 W/m ²		
Suntracking	Green-Off-Off	0x112
• using last received GPS latitude, longitude and altitude		
• system clock stratum ≤ 3		
• sunsensor intensity < 300 W/m ²		
• power save active		
Suntracking	Green-Green	0x022
• using last received GPS latitude, longitude and altitude		
• system clock stratum ≤ 3		
• sunsensor intensity ≥ 300 W/m ²		
Suntracking	Green-Green-Off	0x122
• using last received GPS latitude, longitude and altitude		
• system clock stratum ≤ 3		
• sunsensor intensity ≥ 300 W/m ²		
• power save active		

E.2.4 Instrument status

The instrument status value is in hexadecimal notation (0x<hex>) and is divided into a state field (bits 7 - 0) and a set of flags (bits 31 - 8).

Instrument status	
State bit 7 - 0	Description
2	encoders disabled
3	getting encoder offsets failed
4	failed to find ref sensors
5	ref sensor tests failed
6	slipped
7	not functioning (e.g. FU set illegal)
10	waiting for certain conditions to be met before proceeding (temperature, no motor alarm, LL command)
11	in process of stopping prior to entering next state
15	resetting, requesting encoder offsets
16	resetting, getting encoder offsets
19	resetting, moving to reset position
20	resetting, waiting till reset position reached
21	resetting, testing sensors
22	resetting, moving towards ref sensors
23	resetting, globally finding ref sensors
24	resetting, accurately finding ref sensors
25	resetting, accepting reset
26	resetting, waiting in ref and moving over travel range
27	resetting, preparing for selected function (FU)
28	resetting, preparing for selected function (FU, at home)
29	resetting, preparing for selected function (FU, no default circle)
40	accepting motion commands (not operating autonomously)
50	calculating sun position and pointing at sun, if possible (clear)
51	calculating sun position and pointing at sun, if possible (waiting)
52	calculating sun position and pointing at sun, if possible (tracking)
53	calculating sun position and pointing at sun, if possible (rewinding)
255	undefined
Flags	Description
bit 8	searching for ref
bit 9	operating autonomously
bit 10	unused
bit 11	valid GPS position
bit 12	valid GPS altitude
bit 13	system time synchronized
bit 14	using sun sensor
bit 15	fan on
bit 16	adjustment ok
bit 31 - 17	unused

E.2.5 Motor status

The motor status value is in hexadecimal notation (0x<hex>) and is divided into a state field (bits 7 - 0) and a set of flags (bits 15 - 8).

Motor status	
State bit 7 - 0	Description
0	undefined
1	moving towards reset position
2	on reset position, waiting for other motor
3	moving towards ref sensor
4	accurately finding edge of ref sensor
6	operating normally, moving in response to commands on path
10	finding sun
11	following sun
240	encoder disabled
241	moving due to encoder failure
242	encoder failure
243	movement done
244	moving over travel range
245	waiting in ref
246	wake up
247	power save
248	slipped
249	failed to find ref sensor
252	finding edge of ref sensor
253	synchronizing
254	stopped
255	stopping
Flags	Description
bit 8	in motion
bit 9	ref sensor error
bit 10	ref sensor activated
bit 11	ccw limit sensor activated
bit 12	cw limit sensor activated
bit 13	ref flag set
bit 14	ccw flag set
bit 15	cw flag set

