

WS50PV Compact All-in-One Weather Sensor

Operational Manual



Copyright © OTT HydroMet B.V.

OTT HydroMet B.V.
Delftechpark 36
2628 XH Delft
The Netherlands

+31 15 2755 210
solar-info@otthydromet.com
www.otthydromet.com

All rights reserved.

All content is the intellectual property of OTT HydroMet. Reprinting, duplication and translation (even as excerpts) are only permitted with the prior written consent of OTT HydroMet.

Subject to technical change.

Table of contents

1	Scope of supply	5
2	Order numbers and variant code	6
2.1	Product variants	6
2.2	Accessories and spare parts	6
3	About this manual	7
3.1	Other applicable documents and software	7
3.2	General signs and symbols	7
3.3	Explanation of warnings	8
4	General safety instructions	9
4.1	Intended use	9
4.2	Potential misuse	9
4.3	Personnel qualification	9
4.4	Operator obligations	9
4.5	Personnel obligations	9
4.6	Correct handling	9
4.7	Health hazards	10
4.7.1	Risk of electrical shock	10
4.7.2	Beware of hair being sucked in	10
4.7.3	Beware of warm surfaces	10
4.8	Soiling of the surface	10
4.9	Working outdoor	10
4.9.1	Installation and maintenance at great heights	10
4.9.2	Using long cables	10
4.10	Certification	11
5	Product description	12
5.1	Design and function	12
5.2	Product overview	12
6	Transport, storage, and unpacking	13
6.1	Unpacking	13
6.2	Storage	13
7	Installation	14
7.1	Mechanical installation	14
7.1.1	Required tools and aids	14
7.1.2	Choosing a site	14
7.1.3	Installing device	14
7.1.4	Fastening	15

7.1.5	Aligning to north	15
7.1.6	Installing external rain gauge	16
7.2	Electrical installation	17
7.2.1	Electrical connections	17
7.2.2	Supply voltage	17
7.2.3	RS485 Interface	18
7.2.4	Connecting external sensors	18
8	Commissioning for MODBUS format	19
8.1	Basics	19
8.2	Modbus communication parameter	19
8.3	Supported Modbus functions	19
8.4	Modbus RTU frame	20
8.5	Setup instruction with Modbus Poll	20
8.6	Holding register (configuration settings)	22
8.7	Input register (measurement values)	23
8.8	Status and service register	25
9	Maintenance	26
9.1	Maintenance schedule	26
9.2	Updating firmware with HexLoad	26
10	Troubleshooting	28
10.1	Error elimination	28
11	Repair	29
11.1	Customer support	29
12	Notes on disposing of old devices	30
13	Technical data	31
13.1	General technical data	31
13.2	Electrical data	31
13.3	Dimensions and weight	31
13.4	Measuring range and accuracy	32

1 Scope of supply

The following items are included with delivery:

- Compact All-in-One Weather Sensor
- Instruction Sheet
- Calibration Certificate

2 Order numbers and variant code

2.1 Product variants

Variant	Order number
WS50PV	8373.PV

2.2 Accessories and spare parts

Item	Order number
External rain gauge WTB100	8353.10
External temperature sensor WT1	8160.WT1
Connection cable 10 m	8370.UKAB10
Connection cable 20 m	8370.UKAB20
Connection cable 30 m	8370.UKAB30
Connection cable 50 m	8370.UKAB50

3 About this manual

3.1 Other applicable documents and software

The following documents and software contain further information on installation, maintenance and calibration and can be downloaded at www.otthydromet.com/:

- WS50PV Instruction Manual – Modbus®
- Instruction Sheet
- Firmware
- Data Sheet
- HexLoad Tool

3.2 General signs and symbols

The signs and symbols used in the operational manual have the following meaning:

Practical tip



This symbol indicates important and useful information.

Action

- ✓ Prerequisite that must be met before performing an action.
 - ▶ Step 1
 - ⇒ Intermediate result of an action
 - ▶ Step 2
- ⇒ Result of a completed action

List

- List item, 1st level
 - List item, 2nd level

3.3 Explanation of warnings

To avoid personal injury and material damage, you must observe the safety information and warnings in the operating manual. The warnings use the following danger levels:

WARNING

WARNING

This indicates a potentially hazardous situation. If the hazardous situation is not avoided, it may result in death or serious injuries.

CAUTION

CAUTION

This indicates a potentially hazardous situation. If the hazardous situation is not avoided, it may result in moderately serious or minor injuries.

NOTICE

NOTE

This indicates a situation from which damage may arise. If the situation is not avoided, products may be damaged.

4 General safety instructions

4.1 Intended use

The compact all-in-one weather sensor is used to measure the most critical weather parameters for commercial and industrial PV monitoring.

4.2 Potential misuse

Any use of the product that does not comply with the intended use, be this intentional or negligent, is forbidden by the manufacturer.

- ▶ Use the product only as described in the operational manual.

4.3 Personnel qualification

The equipment described in this manual must be installed, operated, maintained and repaired by qualified personnel only.

- ▶ Obtain training from OTT HydroMet if necessary.

4.4 Operator obligations

The installer is responsible for observing the safety regulations. Unqualified personnel working on the product can cause risks that could lead to serious injury.

- ▶ Have all activities carried out by qualified personnel.
- ▶ Ensure that everybody who works on or with the product has read and understood the operational manual.
- ▶ Ensure that safety information is observed.
- ▶ File the operational manual together with the documentation of the entire system and ensure that it is accessible at all times.
- ▶ The operational manual is part of the product, forward the operational manual together with the product.

4.5 Personnel obligations

To avoid equipment damage and injury when handling the product, personnel are obliged to the following:

- ▶ Read the operational manual carefully before using the product for the first time.
- ▶ Pay attention to all safety information and warnings.
- ▶ If you do not understand the information and procedure explanations in this manual, stop the action and contact the service provider for assistance.
- ▶ Wear the necessary personal protective equipment.

4.6 Correct handling

If the product is not installed, used and maintained correctly, there is a risk of injury. The manufacturer does not accept any liability for personal injury or material damage resulting from incorrect handling.

- ▶ Install and operate the product under the technical conditions described in the operational manual.
- ▶ Do not change or convert the product in any way.
- ▶ Do not perform any repairs yourself.
- ▶ Get OTT HydroMet to examine and repair any defects.
- ▶ Ensure that the product is correctly disposed of. Do not dispose of it in household waste.

4.7 Health hazards

4.7.1 Risk of electrical shock

Live parts can cause electric shocks in the event of contact.

- ▶ Never take measurements on live electrical parts.
- ▶ Never touch live electrical parts.

4.7.2 Beware of hair being sucked in

There is a small fan at the bottom of the device. Hair can be sucked into the fan when the device is connected to power.

- ▶ Tie up long hair.

4.7.3 Beware of warm surfaces

As soon the device is connected to power the dome gets heated up to approximately 40 °C. Incidental touch of the warm dome surface can be painful.

- ▶ Be careful of the warm surface when working on the device.
- ▶ Wear protective gloves if necessary.

4.8 Soiling of the surface

Grease from fingers soils the surface. Dust sticks to it, making it more difficult to clean the dome, and the sun burns the dust in.

- ▶ Wear protective gloves when working on the device.

4.9 Working outdoor

4.9.1 Installation and maintenance at great heights

It is advised to mount the product in a certain height. Therefore, there is a risk of falling down.

- ▶ Observe and follow the local safety regulations.
- ▶ Use suitable safety equipment.
- ▶ Inspect the safety equipment before use.
- ▶ Secure the person mounting or maintaining the device against falling down.
- ▶ Secure the device against falling down.

4.9.2 Using long cables

Long cables are required to mount the product at great heights. Therefore, there is a risk of strangulation.

- ▶ Use long cables properly.
- ▶ Observe manufacturer's instructions.
- ▶ Observe safety regulations.

4.10 Certification

CE (EU)

The equipment meets the essential requirements of EMC Directive 2014/30/EU.

FCC (US)

FCC Part 15, Class "B" Limits

This device complies with part 15 of the FCC Rules. Operation is subject to the following two conditions:

1. This device may not cause harmful interference.
2. This device must accept any interference received, including interference that may cause undesired operation.

IC (CA)

Canadian Radio Interference-Causing Equipment Regulation, ICES-003, "Class B"

This Class B digital apparatus meets all requirements of the Canadian Interference-Causing Equipment Regulations.

5 Product description

5.1 Design and function

The compact all-in-one weather sensor measures the most critical weather parameters such as:

- Air temperature
- Relative humidity
- Air pressure
- Wind direction
- Wind speed

An external temperature or rain sensor can be added to the single-wire digital Modbus interface. The sensor supports the serial transmission mode Modbus®-RTU.

The sensor is suitable for the following applications:

- Commercial PV monitoring
- Community Solar

5.2 Product overview

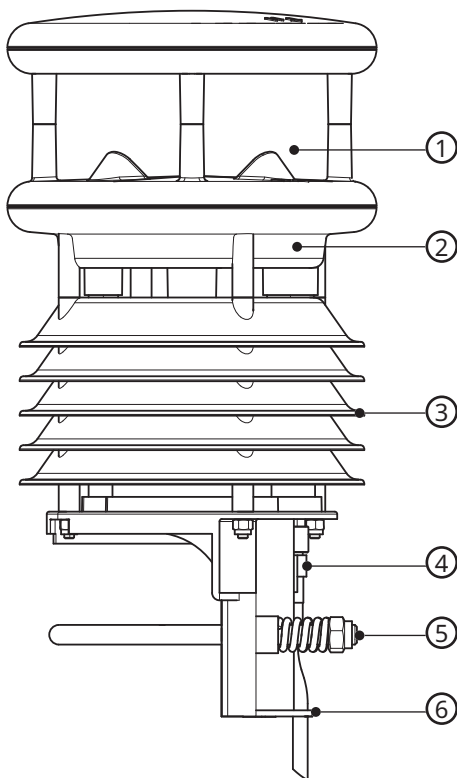

- | | | | |
|---|-------------------------------------------------------|---|--------------------------------------|
| 1 | Ultrasonic anemometer (heated) | 4 | Connector |
| 2 | Air pressure sensor | 5 | Mounting bracket |
| 3 | Air temperature and relative humidity sensor with fan | 6 | Notch for attaching connection cable |

6 Transport, storage, and unpacking

6.1 Unpacking

- ▶ Carefully remove the product from the packaging.
- ▶ Check that the delivery is complete and undamaged.
- ▶ If you find any damage or if the delivery is incomplete, then immediately contact your supplier or manufacturer.
- ▶ Keep the original packaging for any further transportation.

6.2 Storage

- ▶ Store within specified temperature ranges.
- ▶ Store in dry area.
- ▶ Store in original box where possible.

7 Installation

7.1 Mechanical installation

7.1.1 Required tools and aids

The following tools and aids are required:

- open-end or ring spanner, SW 13
- compass

7.1.2 Choosing a site



Risk of injury due to improper installation!

If the mast or the device is installed improperly, damage to the device and injury to people may result.

- ▶ Ensure that the mast stands on a stable surface.
- ▶ Ensure that the mast is sized and anchored appropriately.
- ▶ Ensure that the mast is earthed in accordance with the regulations.
- ▶ Use only approved and tested appliances (conductors, risers etc.) to install the device on the mast.

- ▶ Ensure the following at the site:
 - Free access to the equipment for maintenance works
 - Reliable power supply for permanent operation
 - Good network coverage when transmitting over a mobile communications network

7.1.3 Installing device

For accurate compass readings, an aluminium mast is recommended.

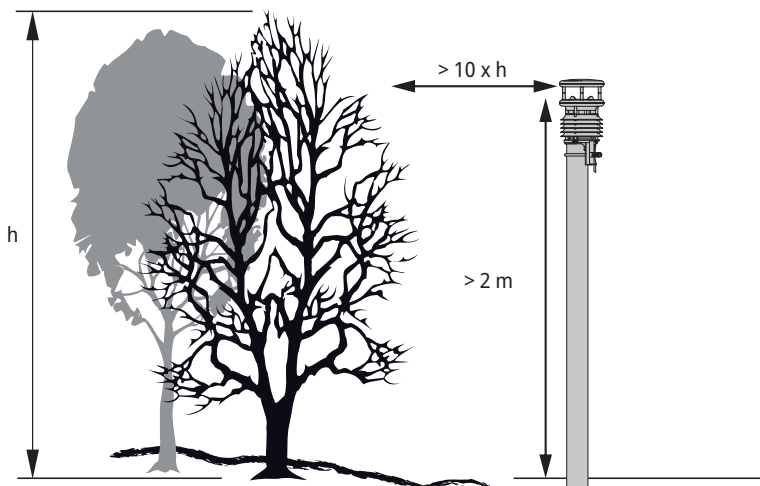

- ▶ Install the device on top of the mast at least 2 m above the ground.
- ▶ Ensure there is free field around the device.

i Buildings, bridges, embankments and trees may corrupt the wind measurement. Passing traffic may cause gusts which may influence the wind measurement.

7.1.4 Fastening

The mounting bracket is designed to be installed on top of a mast with a diameter of 60 to 76 mm or on a suitable mast crossbeam.

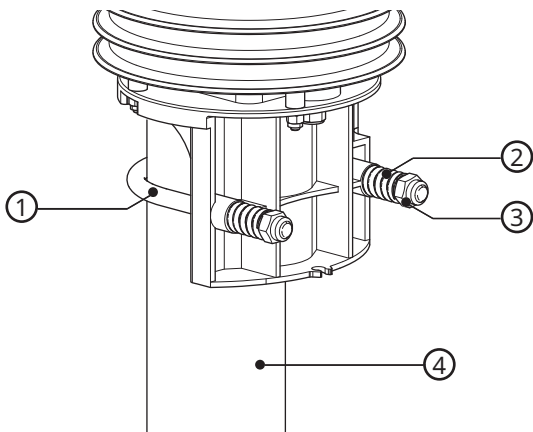

1 Mounting bracket

2 Spring

3 Nut with washer

4 Mast

- ▶ Loosen the nuts.
- ▶ Push the device onto the top of the mast or crossbeam from above.
- ▶ Tighten the nuts evenly until they touch the springs but the device can still be moved easily.
- ▶ Align the device to the north.
- ▶ Tighten both nuts with 3 revolutions.

7.1.5 Aligning to north

In order for the wind direction to be displayed correctly, the device must be aligned to the north. The device has a number of directional arrows for this purpose.

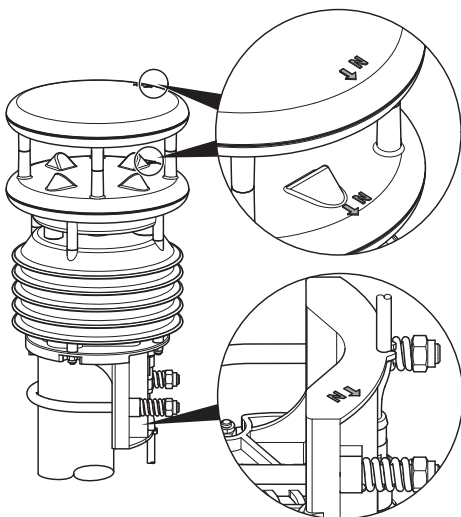

- ▶ If the device is already installed, loosen both nuts evenly until the device can be turned easily.
- ▶ Using the compass, identify the north and fix a point of reference on the horizon.

- ▶ Position the device in such a way that the south and north wind sensors are aligned with the fixed point of reference in the north.

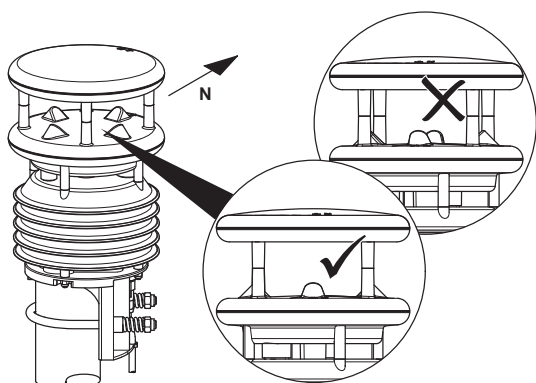

- ▶ Tighten both nuts with 3 revolutions.

i The magnetic North Pole displayed by the compass differs from the Geographic North Pole. When aligning the device, the declination (variation) at the location must be taken into account. Depending on the location, the deviation can be more than 15°, for example in North America. In Central Europe the variation is less than 3° and can be neglected.

7.1.6 Installing external rain gauge

The resolution of the rain gauge can be modified by the reduction ring delivered with the sensor from 0.2 mm to 0.5 mm. All rain sensors with bounce-free reed contact (normally open or normally closed) and with a resolution of 0.1 mm, 0.2 mm, 0.5 mm or 1.0 mm can be used.

- ▶ Mount the reduction ring on the funnel to set the resolution to 0.5 mm.
- ▶ Mount the funnel without the reduction ring to set the resolution to 0.2 mm.
- ▶ Set the resolution in the register address 212. See the WS50PV Instruction Manual – Modbus®

7.2 Electrical installation

i Ultrasonic device do generate noise close-by the device and not hearable by humans.

7.2.1 Electrical connections



WARNING

Electric shock due to incorrectly connected device!

If the device is not connected correctly, it may be permanently damaged and an electric shock may result.

- ▶ Ensure that the device is connected correctly.
- ▶ Ensure that the cable shielding is connected to earth in the electrical cabinet.
- ▶ Remove the yellow protective cap before plugging the device in.

There is an 8-pole screw connector on the underside of the device. This serves to connect the supply voltage and the interfaces via the connection cable.

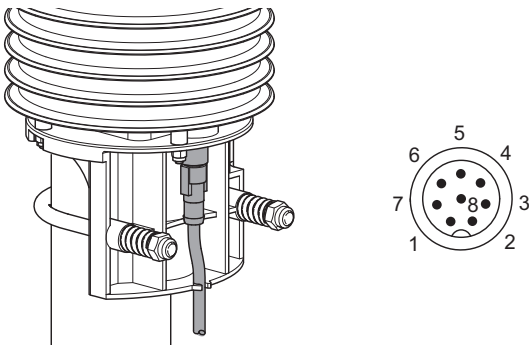

Pin assignment

Number	Color	Assignment
1	White	Supply voltage ground
2	Brown	Positive supply voltage (12 – 24 V)
3	Green	RS485_A (+)
4	Yellow	RS485_B (-)
5	Gray	External sensor a
6	Pink	External sensor b
7	Blue	Heating voltage ground
8	Red	Positive heating voltage

i The supply voltage and the heating voltage are protected against polarity reversal.

7.2.2 Supply voltage

The supply voltage is 4 to 30 V DC. The power supply unit used must be approved for operation with equipment of protection class III (SELV). Operation with a supply voltage of 24 V is recommended. Limitations apply in case of supply voltages lower than 12 V.

7.2.2.1 Limitations in 12 V mode

If the heating is operated on 12 V DC, the functional restrictions in winter operation has to be kept in mind. A heating voltage of 24 V DC is recommended to guarantee full heating duty.

7.2.2.2 Limitations with supply voltage below 12 V

When operating devices with a supply voltage lower than 12 V DC, the fan is not switched on regardless of the fan operating mode. This may influence the accuracy of the temperature and humidity measurement in case of intensive solar radiation or calm wind situations and lead to deviations of the compass measurement values.

7.2.3 RS485 Interface

The device has an electrically isolated, half-duplex, 2 wire RS485 interface for configuration, measurement polling and the firmware update.

7.2.4 Connecting external sensors

External temperature and precipitation sensors can be connected to the device. The connection is made via the standard connector plug of the device and the external sensor will be connected at the end of the delivered cable. All external sensors are unipolar, so any connection sequence can be chosen.

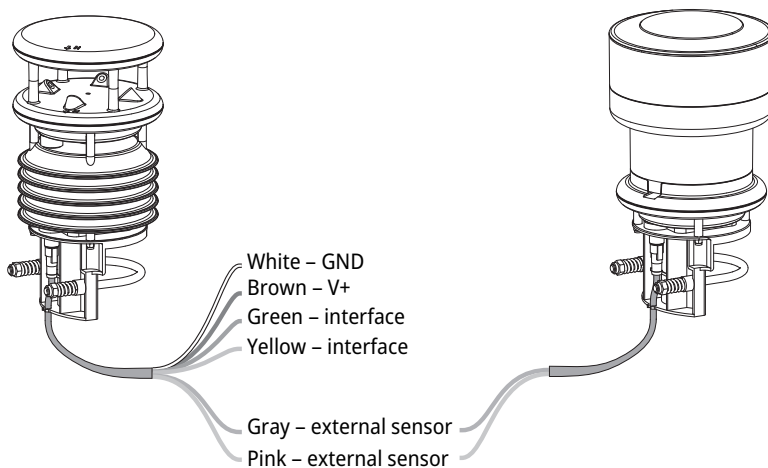

Connection WS50PV and external rain gauge (WTB100)

- ▶ Avoid parasitic coupling when connecting.
- ▶ Use a short cable for the connection.
- ▶ When the external sensor is mounted near to the device while the control cabinet is distant, install an additional distribution box.
- ▶ Connect the external sensor to the gray and pink wires of the connection cable.
- ▶ Set the sensor type in the holding register.

8 Commissioning for MODBUS format

8.1 Basics

The WS50PV supports the serial transmission mode MODBUS-RTU. It is assumed the user has already basic knowledge of Modbus® RTU communications. In addition to this chapter there is a full WS50PV Modbus description available, that includes all available measuring and configuration parameter:



- The WS50PV settings could be read or changed by using 15 Holding Registers, starting from 200. See section
- Measurement values could be read in nearly 200 Input Registers. See section
- All measurement or setting values are mapped to 16-bit integers using suitable scaling factors.

8.2 Modbus communication parameter

Parameter	Value
Modbus operating modes	MODBUS-RTU (Polling Mode only)
Baud rate	19200 (2400, 4800, 9600, 19200, 38400, 57600)
Interface Setting	8E1, 8N1, 8N2
WS50PV Device ID address range	1 ... 99 (ascending order)
Hardware Interface	RS485, 2 wire

8.3 Supported Modbus functions

The functions of conformance class 0 and 1 have been implemented as far as they are applicable for the device, i.e., all functions operating on register level.

Function Code	Conformance Class 0	Used for / Description
0x03	Read Holding Registers	Reading configuration settings from register addresses 200 to 214
0x16	Write Multiple Registers	Writing configuration settings
	Conformance Class 1	
0x04	Read Input Registers	Reading measurement values and status information
0x06	Write Single Register	Writing a single configuration setting
	Diagnostics	
0x11	Report Server ID	Finding device Responds to broadcast with address 255

8.4 Modbus RTU frame

The Modbus remote terminal unit frame starts and ends with a silent mode of 3.5 character times. The first figure shows how the full frame looks like and the second figure shows an example to read input register.

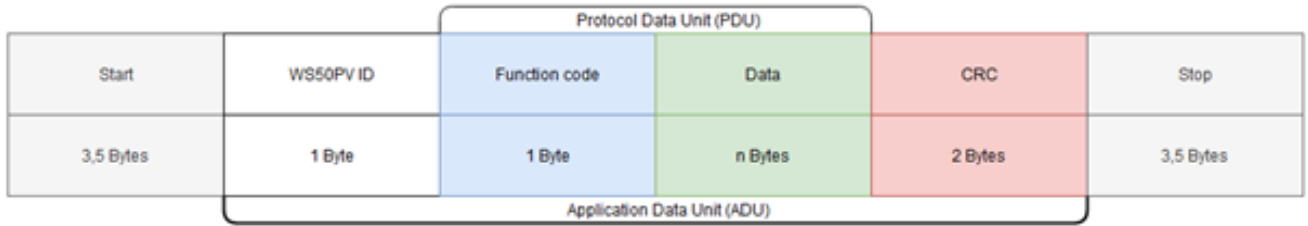

Overview Modbus RTU frame

request message: decimal numbers	1	4	0	0	0	10	112	13
request message: hex code	01	04	00	00	00	0A	70	0D
	WS50PV mit ID1	Function code 4: Read Input Registers	Start Adr.:0		Num. of requested registers:10		2 Bytes CRC	

Example Modbus RTU frame, read input register

request message: write single register	01	06	00	CC	00	52	C8	08
	WS50PV mit ID1	Function code 6: Write Single Register	Start Addr. 204 00CC hex altitude		New Value: 82 0052hex 82m		2 Bytes CRC 08C8	

Example Modbus RTU frame, write single register

8.5 Setup instruction with Modbus Poll

The software Modbus Poll is used on behalf of available software packages in the market to illustrate how to read the configuration setting of the WS50PV.

- ▶ Open the software and configure the interface (WS50PV standard setting).

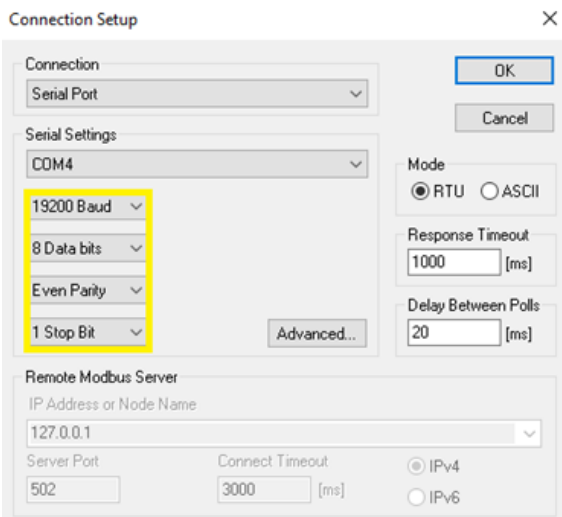

- ▶ Open Setup > Read/Write Definition and read 15 configuration settings starting from register 200.

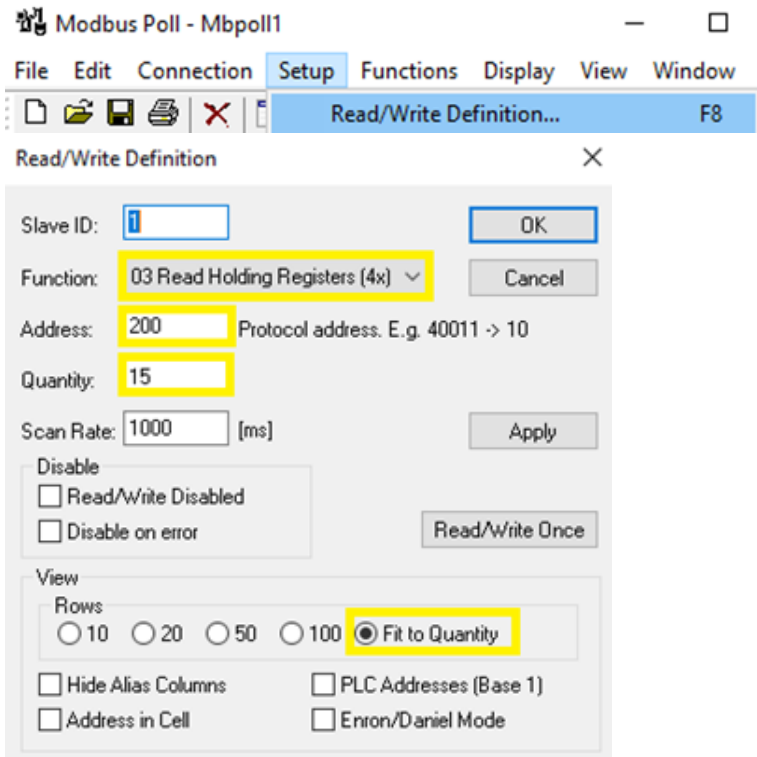

⇒ Output data of holding register:

The screenshot shows the main window of Mbpoll1. The status bar at the top displays 'Tx = 1072: Err = 0: ID = 1: F = 03: SR = 1000ms'. Below the status bar is a table with the following data:

	Alias	00200
200	device ID	1
201		6
202		0
203		1
204		0
205		0
206		0
207		3
208		0
209		50
210		500
211		0
212		0
213		0
214		0

- ▶ For data interpretation, see the following section.

8.6 Holding register (configuration settings)

Reg. addr.	Function R/W	Default	Value	Data type	Scaling
200	R/W device ID	1	Value range: 1 ... 245 (ascending order)	u16	1
201	R/W baud rate	6	6 = 19200; 12 = 9600	u16	1
202	R/W parity	1	0 = no 1 = even	u16	1
203	R/W stop bits	1	1 = 1 Stop Bit 2 = 2 Stop Bit	u16	1
204	R/W altitude	0	Local altitude in m, for calculation of relative air pressure (ref. to sea level) Value range: -99 ... 4999	s16	1
205	R/W compass deviation	0	Local deviation for the correction of compass heading. Dependent on the location of the installation the local declination of the earth magnetic field must be considered. Value range -359 ... 359	s16	1
206	R/W compass correction	0 (off)	0 = off/disabled, manual positioning of the sensor 1 = on/enabled With activated compass correction all wind direction values will be corrected according to the alignment of the sensor, as evaluated by the compass. NOTE: If compass correction is enabled, but the compass returns an error status, the wind direction will also return an error.	u16	1
207	R/W minimum wind speed	3 (is equal to 0.3 m/s)	Minimum wind speed in m/s from which a measurement is transmitted Value Range: 0 ... 100 (is equal to 0 ... 10 m/s) For example, the default setting 3 is equaling to 0.3 m/s. In this case the wind speed less than 0.3 m/s will be reported with 0 m/s by the device.	u16	10
208	R/W Heating Mode	0 (auto)	0 = Auto (recommended) 1 = Mode1 2 = Off 3 = reserved	u16	1
209	R/W temperature threshold for heating mode ' Mode1 '	50 (is equal to 5 °C)	Environment temperature when the heater regulation should be active (only for Mode1 heating mode) If the heater Mode1 was selected (see Register 208) and Mode1 temperature is set to 50, the heater will be activated only below 5 °C. Range: 0 ... 100 (is equal to 0 ... 10 °C)	s16	10

Reg. addr.	Function R/W	Default	Value	Data type	Scaling
210	R/W setpoint temperature for heating	500 (is equal to 50°C)	Target temperature in °C for the wind sensor heating Range: 50 ... 500 (is equal to 5 ... 50 °C)	s16	10
211	R/W external sensor	0: none	0 = none 1 = temperature 2 = rain gauge	u16	1
212	R/W rain gauge resolution	0: (is equal to 0.2 mm)	Resolution setting for external rain gauge 0 = 0.2 mm 1 = 0.5 mm 2 = 0.1 mm 3 = 1.0 mm	u16	1
213	R/W Reset abs. Rain	12871d (0x3247)	Function only when writing to the register, reading will give 0 always. When writing the value 0x3247 (12871d) to this register the stored absolute rain amount will be set to 0. Subsequently a device reset will be initiated.	u16	1
214	R/W Device reset	12871d (0x3247)	Function only when writing to the register, reading will give 0 always. When writing the value 0x3247 (12871d) to this register a device reset will be initiated.	u16	1

Configuration register

8.7 Input register (measurement values)

The input registers are containing the measurement values of WS50PV and the related status information. The most frequently used measurement data can be read with a few or even a single register block request. The figure below shows the address range for imperial and metric units.

The basic input register addresses 0 ... 7 are used to identify the device:

Reg. addr.	Description	Update intvl.	Data type	Scaling
0	Device Type ID, 933	–	u16	1
1	Version of data model (register definition), range 400 to 499, first production version 400	–	u16	1
2	Operation mode Always 1 = Normal	–	u16	1
3	Device status	On event	u16	1
4	4 reserved	–	–	–
5	Consecutive number in batch	–	u16	1
6	Production year and month	–	u16	1
7	Firmware version	–	u16	1

Modus basic device identification parameter

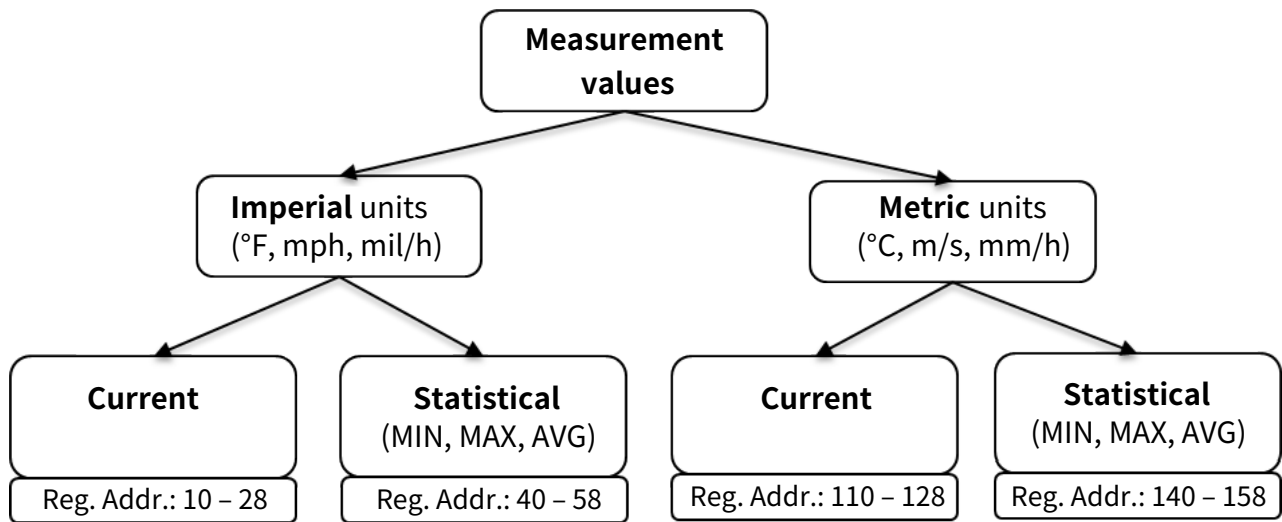

Register address for imperial and metric units

- MIN/MAX Corresponding value is calculated via the circular buffer at 5-minute interval In the case of wind direction, the MIN/MAX value indicates the direction at which the minimum / maximum wind speed was measured.
- AVG Moving average is calculated via the circular buffer at 5-minute interval.
- VCT Vectorially calculated measurements at 5-minute interval.

The following tables show the register addresses for frequently used measurement parameter. "CV" stands for current or actual value. The value of the last measurement in accordance with the specified sampling rate. The statistical value (STAT) in the table can be either MIN/ MAX, AVG or VCT.

Imperial		Metric		Measurement value	Units (Imp. Metric)	Data type	Scaling
CV	STAT	CV	STAT				
10	40	110	140	Device status	-	u16	1
11	41	111	141	Air temperature	°F °C	s16	10
12	42	112	142	Dew point temperature	°F °C	s16	10
13	43	113	143	Relative humidity	%	u16	10
14	44	114	144	Rel. air. pressure	hPa	u16	10
15	45	115	145	Abs. air. pressure	hPa	u16	10
16	46	116	146	Wind direction	°	u16	1
17	47	117	147	Wind speed	mph m/s	u16	10
18	48	118	148	Wind speed	mph m/s	u16	10
19	49	119	149	Wind speed	mph m/s	u16	10

Modbus register for frequently used measurement parameter

External sensors (requires additional accessories)

Imperial		Metric		Measurement value	Units (Imp. Metric)	Data type	Scaling
CV	STAT	CV	STAT				
23	53	123	153	External sensor temperature	°F °C	s16	10
24	54	124	154	Total precipitation high	mil mm	u16	1
25	55	125	155	Total precipitation low	mil mm	u16	1
26	56	126	156	Precipitation diff.	mil mm	u16	1
27	57	127	157	Precip. intensity	mil/h mm/h	u16	1
28	58	128	158	Precip. type code	digit	u16	1

Modbus register for frequently used measurement parameter, external sensors

A full overview including the measuring range for each parameter is available in:
WS50PV Instruction Manual – Modbus®

8.8 Status and service register

The register address range 70 ... 88 contains additional status values related to each measurement parameter that is updated with each measuring interval. As example, in register 78 the absolute humidity (aH) sensor status is available and in 79 the buffer fill rate state of aH for the statistical calculations. A full list of parameter and the different codes per sensor can be found in section 2.3.5 and 2.4 of the WS50PV Instruction Manual – Modbus®.

The following table shows basic housekeeping, service status values.

Register address	Measurement value	Meas. type	Measurement range			Update intvl.	Data type	Scaling
			min	max	unit			
180	Run time high	CV	0	4294967295	sec	1 sec	u16	1
181	Run time low	CV	0	4294967295	sec	1 sec	u16	1
182	Supply voltage	CV	0	50	V	1 min	u16	10
183	Reserved	–	–	–	–	–	–	–
184	SW reset counter	CV	0	65535	digits	on event	u16	1
185	Total operating hours high	CV	0	4294967295	h	1 h	u16	1
186	Total operating hours low	CV	0	4294967295	h	1 h	u16	1

Modbus service register

9 Maintenance

9.1 Maintenance schedule

The frequency of cleaning is dependent upon the local weather and environmental conditions.

The following maintenance intervals are recommended:

Interval	Activity	Performed by
Annually	<ul style="list-style-type: none"> ▶ Check the device for cleanliness. ▶ Check the device by carrying out a measurement request. ▶ Check the operation of the fan. 	Operator
Annually	<ul style="list-style-type: none"> ▶ Have a calibration check performed. 	OTT HydroMet

9.2 Updating firmware with HexLoad

i If one of the below prerequisites is not met by the available installation, the WS50PV must be connected separately with the PC the firmware update is executed on.

- ✓ Only one WS50PV is available on the RS-485-Bus.
- ✓ No RS-485 master is active.
- ✓ The RS-485 infrastructure is able to handle baud rate and parity settings automatically.
- ✓ 19200 baud and 8N1 are supported.
 - ▶ Disconnect the power supply of the sensor.
 - ▶ Connect the PC with installed HexLoad application to the RS-485 interface of the sensor (green and yellow wires). Establish the connection through an USB/RS-485 converter, or through a PC RS232 interface and a RS232/RS-485 converter.
 - ▶ Start the HexLoad application.
 - ▶ Load the latest firmware version (.mot file) with *File > Open*.
 - ⇒ The following text appears in the *Project* window: *WS50PV_Release_vxx.mot*, *xx* specifies the version number.

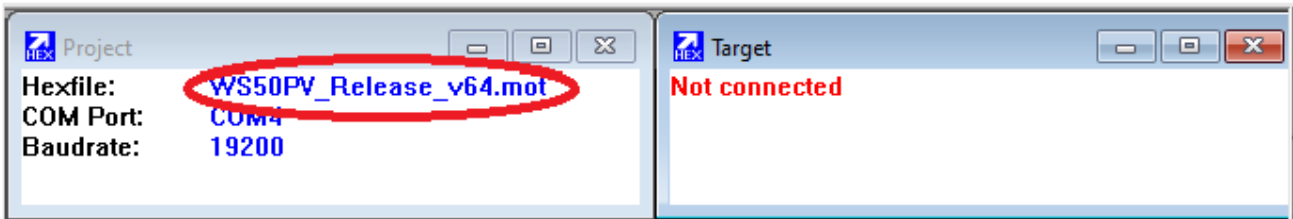

- ▶ Connect the power supply of the sensor.
 - ⇒ The *Target* window is active and the following text appears: *BTL_WSx_V3*.

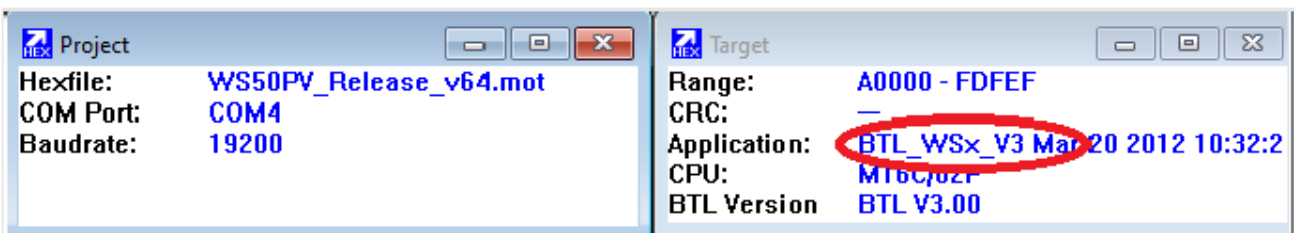

▶ Start the programming with F9.

⇒ If programming is successful, the message *Job succeed* appears.

▶ Exit HexLoad.

⇒ The device is ready for operation with the new firmware.

i Do not disconnect the sensor power supply or the supply of your RS-485 transceiver while the update is being performed.

10 Troubleshooting

10.1 Error elimination

Error	Possible cause	Corrective action
Device does not allow polling or does not respond	Device does not work properly	<ul style="list-style-type: none"> ▶ Check the power supply. ▶ Check the interface connection.
Device does not allow polling or does not respond	Incorrect device ID is applied	<ul style="list-style-type: none"> ▶ Check if the correct device ID is assigned. Devices are delivered with ID 1.
Device measures precipitation, but it is not raining	Device installed incorrectly	<ul style="list-style-type: none"> ▶ Check that the device was installed correctly in accordance with the instructions.
Measured temperature appears too high / measured humidity appears too low	Fan does not work properly	<ul style="list-style-type: none"> ▶ Check whether the fan on the underside of the device is working.
Wind direction values are incorrect	Device is not aligned correctly	<ul style="list-style-type: none"> ▶ Check that the device is aligned to the north.
Quality of the wind measurement is not always 100 %	In normal operation the device should always transmit 90 – 100 %. Values up to 50 % do not represent a general problem. If the device permanently transmits values below 50 %, this may mean that there is a fault.	–
Device transmits an unknown error	–	<ul style="list-style-type: none"> ▶ Check if the error is listed in the input register, register addresses 180 to 186. ▶ If the error is not listed, then contact the technical support department of OTT HydroMet.
Input register transmits an error (65530 for unsigned and 32762 for signed values)	–	<ul style="list-style-type: none"> ▶ Check the status of the corresponding input status register, register addresses 70 to 88. ▶ For the coding of the sensor status see the WS50PV Instruction Manual – Modbus®.

11 Repair

11.1 Customer support

- ▶ Have repairs carried out by OTT HydroMet service personnel.
- ▶ Only carry out repairs yourself, if you have first consulted OTT HydroMet.
- ▶ Contact your local representative: www.otthydromet.com/en/contact-us
- ▶ Include the following information:
 - instrument model
 - instrument serial number
 - details of the fault or problem
 - examples of data files
 - readout device or data acquisition system
 - interfaces and power supplies
 - history of any previous repairs or modifications
 - pictures of the installation
 - overview of the local environment conditions

12 Notes on disposing of old devices

Member States of the European Union

In accordance with the German Electrical and Electronic Equipment Act (ElektroG; national implementation of EU Directive 2012/19/EU), OTT HydroMet takes back old devices in the Member States of the European Union and disposes of them in the proper manner. The devices that this concerns are labeled with the following symbol:

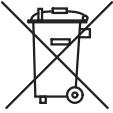

- ▶ For further information on the take-back procedure contact OTT HydroMet:

OTT HydroMet B.V.

Service & Technical Support

Delftechpark 36

2628 XH Delft

The Netherlands

phone: +31 15 2755 210

email: solar-info@otthydromet.com

All other countries

- ▶ Dispose of the product in the proper manner following decommissioning.
- ▶ Observe the country-specific regulations on disposing of electronic equipment.
- ▶ Do NOT dispose of the product in household waste.

13 Technical data

13.1 General technical data

Specification	Value
Fastening	Stainless steel bracket for mast with diameter 60 to 76 mm
Housing	Plastic (PC)
Protection class	III (SELV)
Protection type	IP66
Operating temperature range	-40 to +60 °C
Storage temperature range	-50 to +70 °C
Humidity range	0 to 100 %
Cable length	10 m

13.2 Electrical data

Specification	Value
Power supply and current consumption	12 V DC, 85 mA 24 V DC, 140 mA
Power supply and maximum power consumption with heater on to support full ambient temperature range	24 V DC \pm 10 %, 20 VA
RS-485 interface	2-wire, half-duplex
Communication protocol	Modbus [®]
Output rate	1 min

13.3 Dimensions and weight

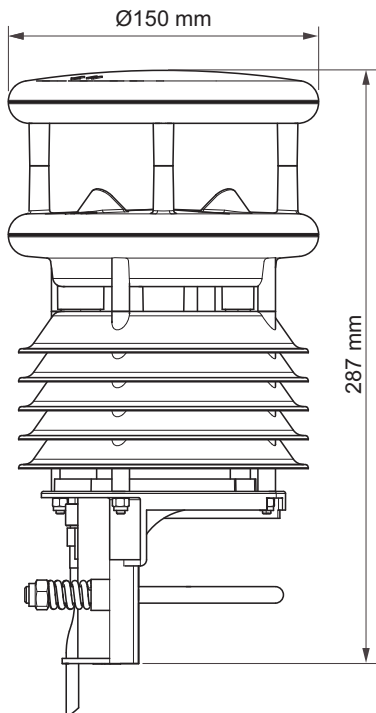

WS50PV, 1200 g

13.4 Measuring range and accuracy

Air temperature

Specification	Value
Measurement process	NTC
Measuring range	-40 °C to +60 °C
Resolution	0.1 °C (-20 °C to +50 °C) otherwise 0.2 °C
Sensor accuracy	±0.5 °C
Units	°C, °F

Relative humidity

Specification	Value
Measurement process	Capacitive
Measuring range	0 to 100 % RH
Resolution	0.1 %
Accuracy	±3 % RH
Units	%

Air pressure

Specification	Value
Measurement process	MEMS capacitive
Measuring range	500 to 1100 hPa
Resolution	0.1 hPa
Accuracy	±0.5 hPa (0 °C to +40 °C)
Units	hPa

Wind speed

Specification	Value
Measurement process	Ultrasonic
Measuring range	0 to 50 m/s
Resolution	0.1 m/s
Accuracy	±0.3 m/s or ±3 % (0 to 35 m/s) otherwise ±5 % RMS
Units	m/s, mph, kts

Wind direction

Specification	Value
Measurement process	Ultrasonic
Measuring range	0 to 359.9°
Resolution	1°
Accuracy	< 5° RMSE (> 1 m/s)
Units	°



The external temperature sensor and rain gauge use the same input, so only one of them can be connected simultaneously.

External temperature sensor WT1/WST1

Specification	Value
Measurement process	NTC
Measuring range	-40 °C to +80 °C
Resolution	0.25 °C
Sensor accuracy	±1 °C (WST1: ±0.3 °C between -10 °C to +10 °C)
Units	°C, °F

External rain gauge WTB100

Specification	Value
Measurement process	Rain gauge with bounce-free reed contact (normally closed)
Resolution	0.2 mm / 0.5 mm (adjustable by reduction ring)
Accuracy	2 %



Contact Information

