

RT1 Rooftop Monitoring System

Operational Manual



Copyright © OTT HydroMet B.V.

OTT HydroMet B.V.
Delftechpark 36
2628 XH Delft
The Netherlands

+31 15 2755 210
solar-info@otthydromet.com
www.otthydromet.com

All rights reserved.

All content is the intellectual property of OTT HydroMet. Reprinting, duplication and translation (even as excerpts) are only permitted with the prior written consent of OTT HydroMet.

Subject to technical change.

Table of contents

1	Scope of supply	5
2	Order numbers and variant code	6
2.1	Product variants	6
2.2	Accessories and spare parts	6
3	About this manual	7
3.1	Other applicable documents	7
3.2	General signs and symbols	7
3.3	Explanation of warnings	8
4	General safety instructions	9
4.1	Intended use	9
4.2	Potential misuse	9
4.3	Personnel qualification	9
4.4	Operator obligations	9
4.5	Personnel obligations	9
4.6	Correct handling	9
4.7	Certification	10
5	Product description	11
5.1	Design and function	11
5.2	Product overview	11
6	Transport, storage, and unpacking	12
6.1	Unpacking	12
6.2	Storage	12
7	Installation	13
7.1	Mechanical installation	13
7.1.1	Preparatory work	13
7.1.2	Required tools and aids	13
7.1.3	Mounting instrument at corner	13
7.1.4	Mounting instrument at edge	14
7.1.5	Installing PV panel temperature sensor	16
7.2	Electrical installation	16
7.2.1	Electrical connections	16
7.2.2	Grounding instrument	17
7.2.3	Power connection	17
7.2.4	Power consumption	17
7.2.5	Connecting to computer	18

8	Commissioning	19
8.1	Instrument set-up	19
9	Operation	21
9.1	Collecting data	21
10	Maintenance	22
10.1	Maintenance schedule	22
11	Troubleshooting	23
11.1	Error elimination	23
12	Repair	24
12.1	Customer support	24
13	Notes on disposing of old devices	25
14	Technical data	26
14.1	Optical and electrical data	26
14.2	Data transfer	26
14.3	Dimensions and weight	27

1 Scope of supply

The following items are included with delivery:

- RT1 housing
- 2 dust caps
- Thumb screw
- Side installation adapter
- Side mounting screw, washer and nut (M5)
- Side mounting PowAR Cinch clamp
- 2-pin plug with 2.9 ± 0.05 m cable with temperature sensor
- 5-pin plug with 20 m cable to host
- 15x cable tie mount and binder, for mounting the cable of the temperature sensor
- Alcohol wipes
- Instruction sheet
- Calibration certificate

2 Order numbers and variant code

2.1 Product variants

Variant	Order number
RT1 Smart Rooftop Monitoring System, PV panel temperature sensor, 20 m cable	0385900

2.2 Accessories and spare parts

Item	Order number
PMU485 Smart Setup Hub converts USB to RS-485 and 12 V DC output for Smart and DustIQ setup and upgrade	0382460

3 About this manual

3.1 Other applicable documents

The following documents and software contain further information on installation, maintenance and calibration:

- Instruction Sheet
- Smart Explorer Software Manual
- Smart Explorer Software

The documents and software can be downloaded at: www.otthydromet.com

3.2 General signs and symbols

The signs and symbols used in the operational manual have the following meaning:

Practical tip



This symbol indicates important and useful information.

Action

- ✓ Prerequisite that must be met before performing an action.
 - ▶ Step 1
 - ⇒ Intermediate result of an action
 - ▶ Step 2
 - ⇒ Result of a completed action

List

- List item, 1st level
 - List item, 2nd level

3.3 Explanation of warnings

To avoid personal injury and material damage, you must observe the safety information and warnings in the operating manual. The warnings use the following danger levels:

WARNING

WARNING

This indicates a potentially hazardous situation. If the hazardous situation is not avoided, it may result in death or serious injuries.

CAUTION

CAUTION

This indicates a potentially hazardous situation. If the hazardous situation is not avoided, it may result in moderately serious or minor injuries.

NOTICE

NOTE

This indicates a situation from which damage may arise. If the situation is not avoided, products may be damaged.

4 General safety instructions

4.1 Intended use

The RT1 radiometer is used to measure solar irradiance on a plane surface and is particularly suitable for monitoring rooftop PV installations.

4.2 Potential misuse

Any use of the product that does not comply with the intended use, be this intentional or negligent, is forbidden by the manufacturer.

- ▶ Use the product only as described in the operational manual.

4.3 Personnel qualification

The equipment described in this manual must be installed, operated, maintained and repaired by qualified personnel only.

- ▶ Obtain training from OTT HydroMet if necessary.

4.4 Operator obligations

The installer is responsible for observing the safety regulations. Unqualified personnel working on the product can cause risks that could lead to serious injury.

- ▶ Have all activities carried out by qualified personnel.
- ▶ Ensure that everybody who works on or with the product has read and understood the operational manual.
- ▶ Ensure that safety information is observed.
- ▶ File the operational manual together with the documentation of the entire system and ensure that it is accessible at all times.
- ▶ The operational manual is part of the product, forward the operational manual together with the product.

4.5 Personnel obligations

To avoid equipment damage and injury when handling the product, personnel are obliged to the following:

- ▶ Read the operational manual carefully before using the product for the first time.
- ▶ Pay attention to all safety information and warnings.
- ▶ If you do not understand the information and procedure explanations in this manual, stop the action and contact the service provider for assistance.
- ▶ Wear the necessary personal protective equipment.

4.6 Correct handling

If the product is not installed, used and maintained correctly, there is a risk of injury. The manufacturer does not accept any liability for personal injury or material damage resulting from incorrect handling.

- ▶ Install and operate the product under the technical conditions described in the operational manual.
- ▶ Do not change or convert the product in any way.
- ▶ Do not perform any repairs yourself.
- ▶ Get OTT HydroMet to examine and repair any defects.
- ▶ Ensure that the product is correctly disposed of. Do not dispose of it in household waste.

4.7 Certification

CE (EU)

The equipment meets the essential requirements of EMC Directive 2014/30/EU.

FCC (US)

FCC Part 15, Class "B" Limits

This device complies with part 15 of the FCC Rules. Operation is subject to the following two conditions:

1. This device may not cause harmful interference.
2. This device must accept any interference received, including interference that may cause undesired operation.

IC (CA)

Canadian Radio Interference-Causing Equipment Regulation, ICES-003, "Class B"

This Class B digital apparatus meets all requirements of the Canadian Interference-Causing Equipment Regulations.

5 Product description

5.1 Design and function

The RT1 radiometer is designed for measuring solar irradiance on a plane surface (radiant flux, W/m^2), which results from the sum of the direct solar radiation and the diffuse sky radiation above the instrument.

The RT1 communicates with readout devices via the RS-485 Modbus® interface. The integrated temperature sensor corrects the temperature dependence of the detector sensitivity. To achieve a low directional error when the sun is low at the horizon the instrument uses a special diffuser.

The instrument is delivered with a waterproof plug pre-wired to a 20 m long signal cable and a PV panel temperature sensor with approx. 2.9 m cable.

5.2 Product overview

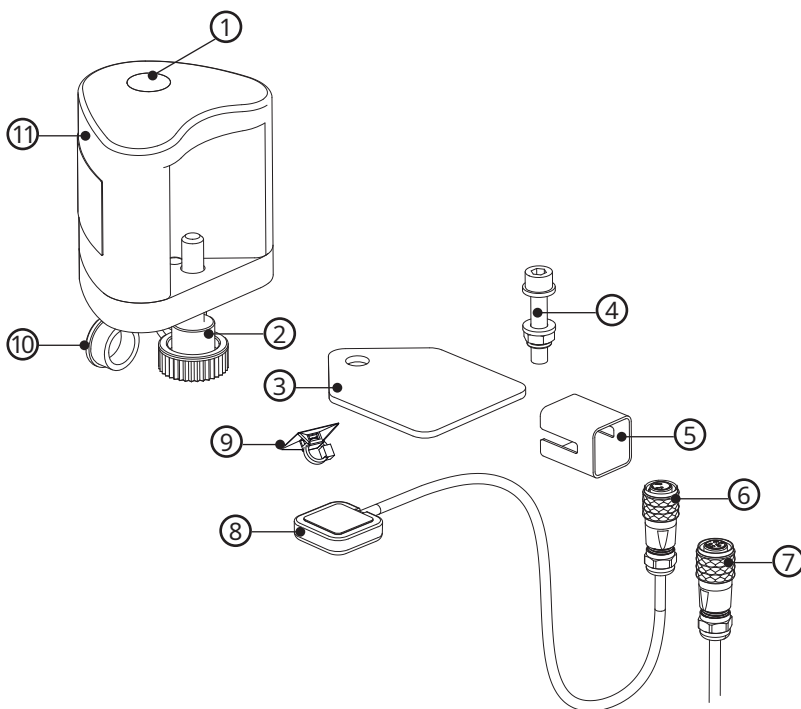

- | | | | |
|---|--|----|---------------------------------|
| 1 | Sensor | 7 | 5-pin plug with 20 m cable |
| 2 | Thumb screw | 8 | PV temperature sensor |
| 3 | Side installation adapter | 9 | 15x cable tie mount with binder |
| 4 | Side mounting screw, washer and nut (M5) | 10 | 2x dust caps |
| 5 | Side mounting PowAR Cinch clamp | 11 | RT1 housing |
| 6 | 2-pin plug with approx. 2.9 m cable | | |

6 Transport, storage, and unpacking

6.1 Unpacking

- ▶ Carefully remove the product from the packaging.
- ▶ Check that the delivery is complete and undamaged.
- ▶ If you find any damage or if the delivery is incomplete, then immediately contact your supplier or manufacturer.
- ▶ Keep the original packaging for any further transportation.

6.2 Storage

- ▶ Store within specified temperature ranges.
- ▶ Store in dry area.
- ▶ Store in original box where possible.

7 Installation

7.1 Mechanical installation

7.1.1 Preparatory work

- ▶ Adjust the RS-485 settings and set the Modbus® address before visiting the site. Otherwise a computer and RS-485 / USB converter is required during installation.

7.1.2 Required tools and aids

No tools are required to fit the instrument to a corner of a PV panel.

If corner mounting is not an option, the following tools are required to secure the adapter plate to the instrument:

- Allen key, 5 mm
- spanner, 10 mm

7.1.3 Mounting instrument at corner

The location of the instrument must be free of any obstructions in the direction of the sky. The instrument must have the same combination of direct, indirect and reflected light as the PV panels. The top corner of a PV panel is the best place to put the instrument as its field of view will be the same as that of the PV panel.

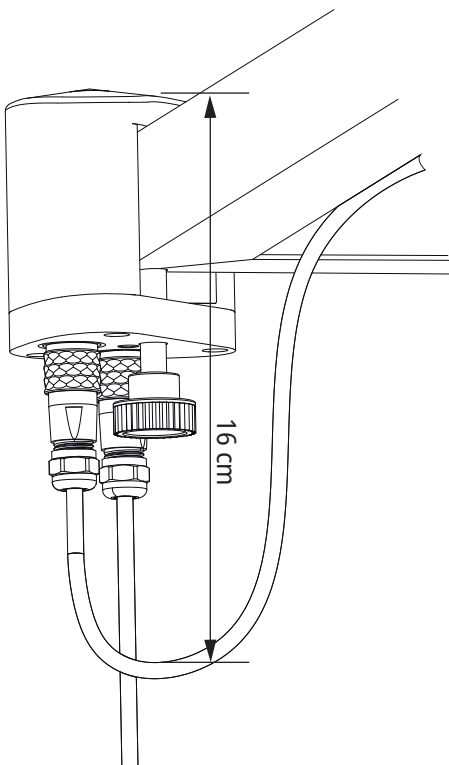

- ▶ Screw out the thumb screw just enough for the instrument to fit over the corner of the PV panel.
- ▶ Position the instrument in such a way that it fits well and snugly to both sides of the PV panel.
- ▶ Turn in the thumb screw until it is hand tight and feels securely fastened. Overtightening the thumb screw can damage the PV panel frame.
- ▶ Once the cable is properly installed, plug in the cable to the host or Modbus® gateway.

7.1.4 Mounting instrument at edge

- ▶ Remove and store the thumb screw.

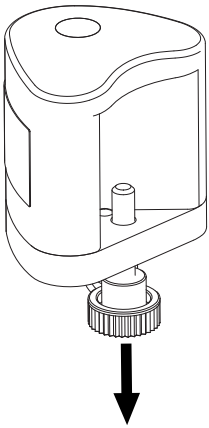

- ▶ Put the adapter plate in the instrument.

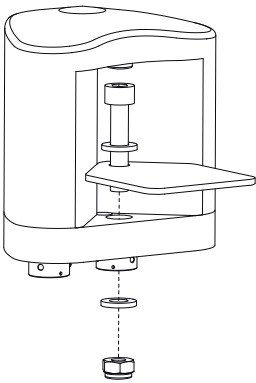

- ▶ Secure the adapter plate with the nut and screw.

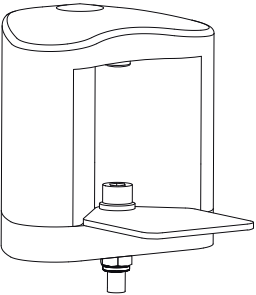

- ▶ Align the instrument with the side of the PV panel.

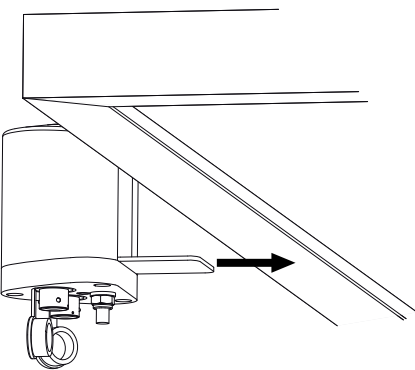

- ▶ Keep the instrument securely in place.
- ▶ Position the PowAR Cinch in front of the adapter plate and ensure that the claws are on the upper side to be in contact with the module aluminum frame.

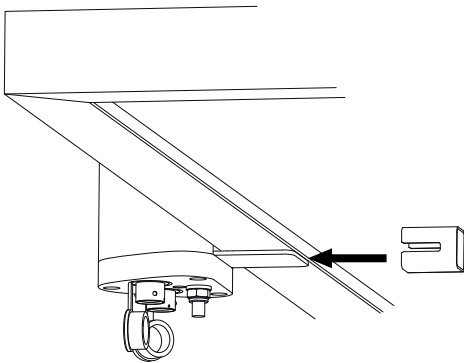

- ▶ Insert the PowAR Cinch and ensure that it is fully engaged. This will require some force or potentially a small hammer.

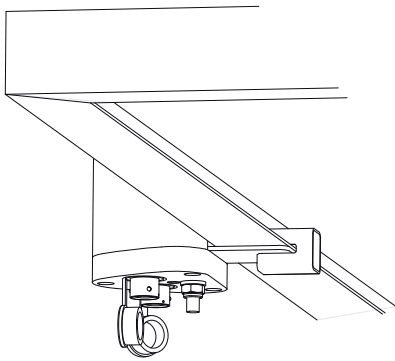

- i** The PowAR Cinch is self-grounding because it serves as a connection between the module frame and the supporting structure and maintains stable electrical contact between the module frame and the adapter plate at several contact points.

7.1.4.1 Dismounting PowAR Cinch

- ▶ Insert a flat-blade, non-insulated screwdriver under the tab to move the two claws up.
- ▶ Pull back the PowAR Cinch until it is disengaged.
- ▶ Dispose of the PowAR Cinch. The PowAR Cinch is for single use.

7.1.5 Installing PV panel temperature sensor

The best location for the temperature sensor is the center back of the PV panel.

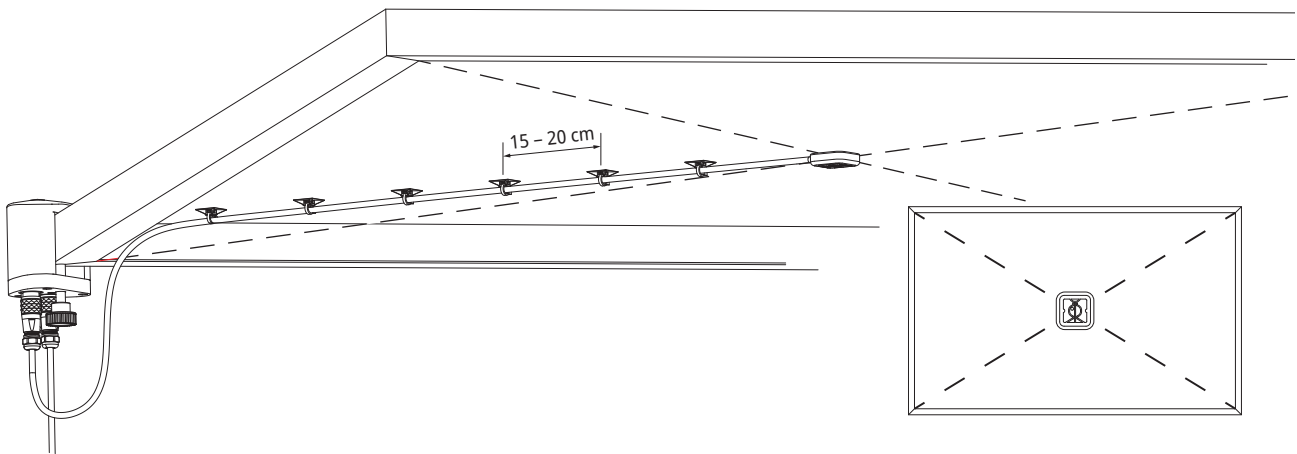

- ▶ From the instrument, pull off the black dust cap of the 2-pin connector.
- ▶ Insert the 2-pin plug in the 2-pin connector of the instrument.
- ▶ Clean the surfaces of the locations for the cable supports and for the PV panel temperature sensor at the back of the PV panel.
- ▶ Stick the temperature sensor to the center back of the PV panel. Place with care as the temperature sensor can not be removed once stuck.
- ▶ Stick the cable tie mounts to the cleaned surfaces at the back of the PV panel.
- ▶ Secure the cable to the cable supports by using tie wraps.

7.2 Electrical installation

7.2.1 Electrical connections

The instrument is supplied with a waterproof connector pre-wired to 20 m of high quality cable with 5 wires and a shield covered with a black sleeve.

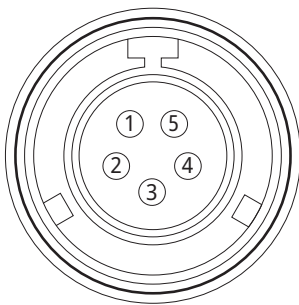

5-pin connector

Pin assignment

Wire Number	Color	Function	Connect to
1	Black	Power ground	Power -
2	White	Power 5 to 30 V DC	Power +
3	Gray	Modbus® RS-485	A/A'/-

Wire			
Number	Color	Function	Connect to
4	Yellow	Modbus® RS-485	B/B'+
5	Green	Modbus® common / Ground	-
Shield		Housing	Ground

i Long cables may be used, but may affect the maximum baud rate of the RS-485 digital connection.

7.2.2 Grounding instrument

NOTICE

Damage due to power or ground loops!

If the instrument is connected to multiple readout devices, this can cause power or ground loops that can damage the instrument.

- ▶ Observe the differential voltage between one of the two Modbus® RS-485 lines (yellow and gray) and the power ground (black) or RS-485 common line (green) and make sure it does not exceed 70 V DC.

The shield of the cable is connected to the aluminum housing of the instrument through the connector body.

- ▶ Secure the instrument on the metal PV panel frame with a good connection to ground, e.g. by using a lightning conductor.
- ▶ Do not connect the cable shield at the data logger or Modbus® gateway.
- ▶ If there is no good ground connection at the instrument, connect the ground at the data logger or gateway.

7.2.3 Power connection

The minimum power supply voltage for the instrument is 5 V DC. 5-volt-power can only be used with a short cable, maximum 10 m. To ensure reliable performance, a voltage of 12 V DC is recommended. For the output of the power supply, it is recommended to protect it with a fast blowing fuse of maximum 250 mA rating.

7.2.4 Power consumption

Voltage (V DC)	Current (mA)	Power (mW)
5	10.0	50
12	4.5	55
24	2.5	60

Typical power consumption for maximum analog output (1 V)

- Maximum power consumption 65 mW at the highest input voltage.
- Maximum input current 12.5 mA at the lowest input voltage.
- Maximum inrush current 200 mA.

7.2.5 Connecting to computer

NOTICE

Damage due to lack of insulation!

The power supply units of portable computers such as laptops can generate large voltage peaks. This may cause damage to the instrument's digital interface.

- ▶ Ensure that the converter has galvanic isolation between the inputs and outputs.

The instrument must be connected to a computer via an RS-485 converter with a USB port.

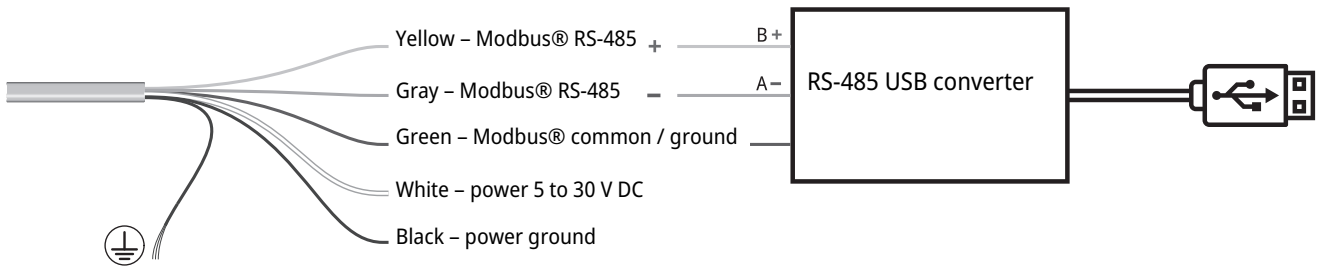

Connection to RS-485 converter

- ▶ Ensure that the power supply is switched off.
- ▶ Connect the white and black wires to the power supply unit.
- ▶ Connect the yellow, gray and green wires to the RS-485 converter.
- ▶ Isolate and seal any other wires when they are not in use.
- ▶ Connect the 5-pin plug to the instrument.
- ▶ Switch on the power supply.
- ▶ Switch on the computer.

8 Commissioning

8.1 Instrument set-up

The Smart Explorer software allows to configure a smart sensor and to collect real-time data.

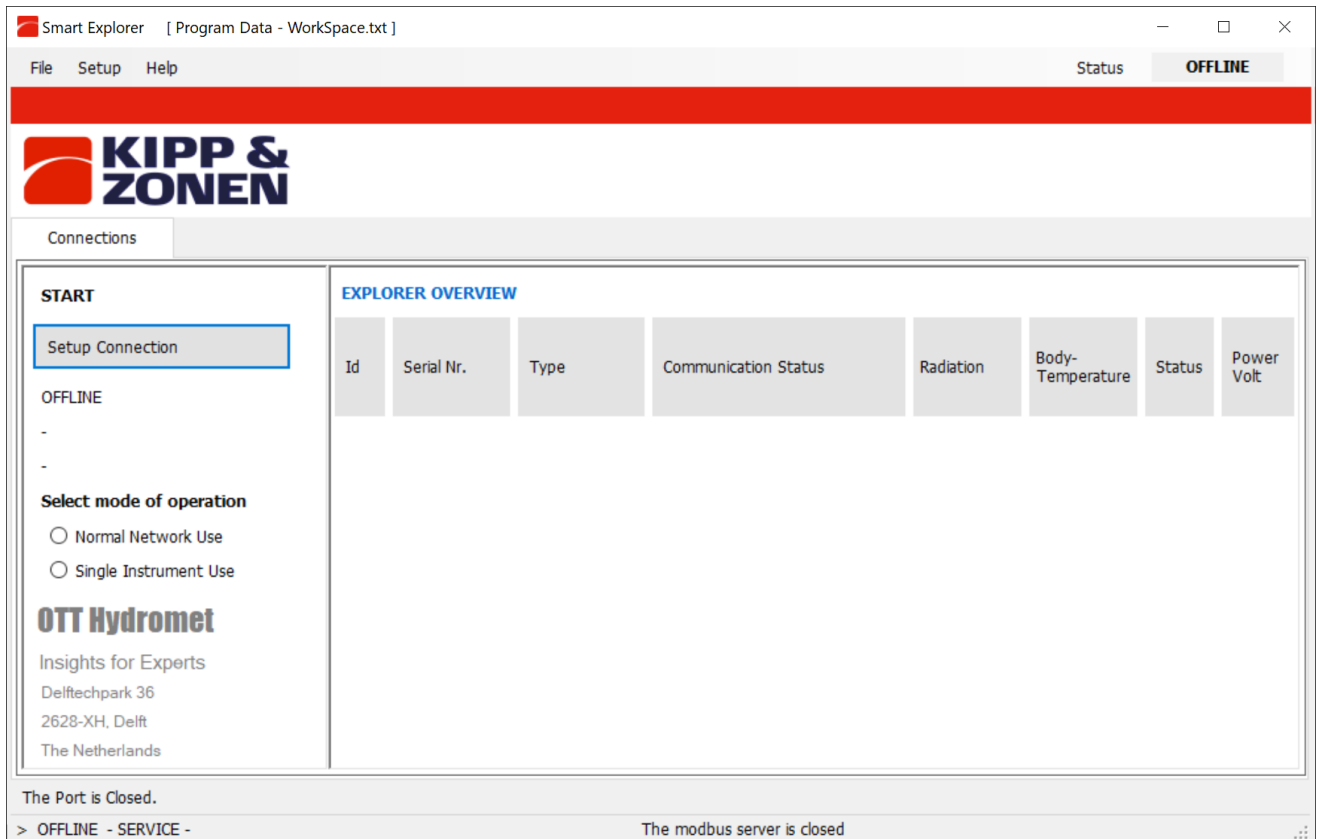

The factory default communication parameters are as follows:

- Modbus® baud rate: 19200
 - Parity: even
 - Data bits: 8
 - Stop bits: 1
 - Address: 1
-
- ▶ If using the software on-site, ensure that the software is already installed on the laptop.
 - ▶ For detailed information about setup, monitoring, and data logging, see the Smart Explore software manual.
 - ▶ Download the Smart Explorer software and the manual at the following address: www.otthydromet.com

From the factory the Modbus® address of the RT1 is set to 1.

- ▶ If the Modbus® address of the RT1 is unknown, connect only 1 instrument to the smart explorer.
 - ▶ Set to *single instrument use*.
 - ▶ Click *send broadcast*.
- ⇒ The RT1 and its Modbus® address will show up in the explorer overview.
- ▶ If communication with the RT1 does not work, connect only 1 instrument to the smart explorer.
 - ▶ Set to *single instrument use*.

▶ Click *start from boot*.

⇒ All communication parameters will be reset to factory default and the Modbus® address of the RT1 will be set to address 1.

9 Operation

9.1 Collecting data

Data collection requirements depend on the application, but a commonly used setting is to sample the data every second and to store one-minute-averages.

10 Maintenance

10.1 Maintenance schedule

The frequency of cleaning is dependent upon the local weather and environmental conditions.

The following maintenance intervals are recommended:

Interval	Activity	Performed by
Monthly	<ul style="list-style-type: none">▶ Clean the sensor using pure alcohol or distilled water and a lint-free cloth. Avoid using harsh chemicals.▶ Ensure that no streaks or residue are left on the sensor surface.▶ Ensure that no streaks or deposits are left on the diffuser.	Operator
Annually	<ul style="list-style-type: none">▶ Check all electrical connections.▶ Check all cables for damage.▶ Loosen and retighten all fixtures to ensure secure attachment and check for corrosion.▶ Check if the instrument mountings and the PV panel temperature sensor are still securely installed.	Operator
2 to 5 years	<ul style="list-style-type: none">▶ Have a recalibration performed.	OTT HydroMet

11 Troubleshooting

11.1 Error elimination

Error	Possible cause	Corrective action
Output signal not available or incorrect	Instrument does not work properly	<ul style="list-style-type: none">▶ Check that the cables are correctly connected to the readout equipment.▶ Check the power supply. 12 - 24 V DC are recommended.▶ Check that the instrument has a unique Modbus® address.▶ Check the location for obstacles that block the direct solar radiation▶ Check the diffusor for contamination. Carry out maintenance work as required.▶ Check the cable to the temperature sensor.▶ Report any malfunctions or damage to the representative of OTT HydroMet.

12 Repair

12.1 Customer support

- ▶ Have repairs carried out by OTT HydroMet service personnel.
- ▶ Only carry out repairs yourself, if you have first consulted OTT HydroMet.
- ▶ Contact your local representative: www.otthydromet.com/en/contact-us
- ▶ Include the following information:
 - instrument model
 - instrument serial number
 - details of the fault or problem
 - examples of data files
 - readout device or data acquisition system
 - interfaces and power supplies
 - history of any previous repairs or modifications
 - pictures of the installation
 - overview of the local environment conditions

13 Notes on disposing of old devices

Member States of the European Union

In accordance with the German Electrical and Electronic Equipment Act (ElektroG; national implementation of EU Directive 2012/19/EU), OTT HydroMet takes back old devices in the Member States of the European Union and disposes of them in the proper manner. The devices that this concerns are labeled with the following symbol:



- ▶ For further information on the take-back procedure contact OTT HydroMet:

OTT HydroMet B.V.

Service & Technical Support

Delftechpark 36

2628 XH Delft

The Netherlands

phone: +31 15 2755 210

email: solar-info@otthydromet.com

All other countries

- ▶ Dispose of the product in the proper manner following decommissioning.
- ▶ Observe the country-specific regulations on disposing of electronic equipment.
- ▶ Do NOT dispose of the product in household waste.

14 Technical data

14.1 Optical and electrical data

Specification	Value
Irradiance	0 to 2000 W/m ²
Spectral range	400 to 1100 nm
Non-stability (change/year)	< 1 %
Non-linearity (0 to 1000 W/m ²)	< 1 %
Directional response (up to 55 ° with 1000 W/m ² beam)	< 1.7 %
Uncertainty in daily total	< 7 %
The combined calibration uncertainty	±3 % against traceable reference pyranometer
PV panel temperature	-40 to +100 °C, ±1 °C, using a 10 k NTC
Calibration	Against traceable reference pyranometer
Signal connections	1 - RS-485 connection to host 2 - PV panel temperature sensor
Voltage and current range	5 to 30 V DC, 2.5 to 10 mA
Power consumption maximum	60 mW
Ambient operating temperature	-40 to +80 °C
Protection rating	IP67 with both plugs securely attached
Supported PV panel heights when mounted on corner	30 to 50 mm
Communication to host	Modbus [®] Slave RTU over 2-wire EIA RS-485 connection 1200 to 38400 baud
Connections on instrument	Two connectors, 5-pin to host and 2-pin to temperature sensor
Cable to host	20 m
Cable to PV temperature sensor	2.9 m ±0.05 m

14.2 Data transfer

Specification	Value
Interface	RS-485
Baud rates	38400, 19200, 9600, 4800, 2400 and 1200
Data bits	8
Parity	Non, even, odd
Stop bits	1, 2

14.3 Dimensions and weight

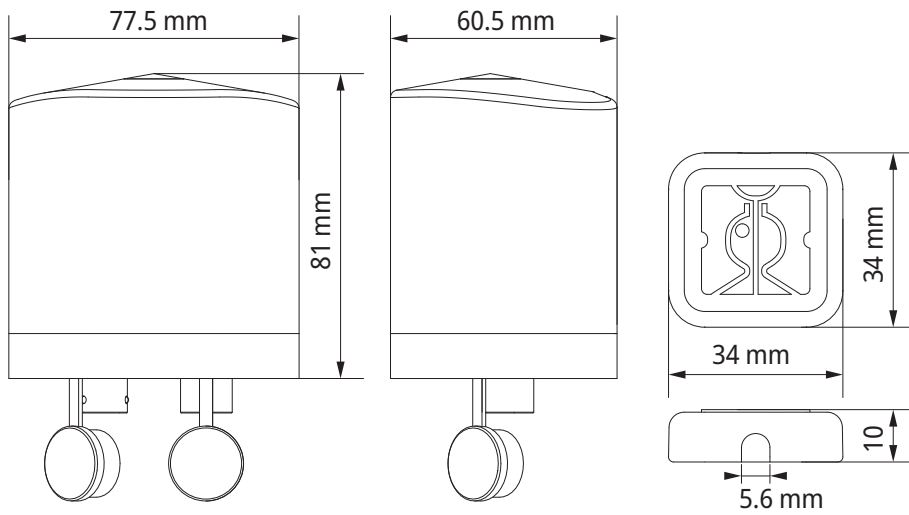

RT1 radiometer and PV panel temperature sensor

Specification	Value
RT1 main body	514 g
Complete boxed unit	1710 g



Contact Information

