

Road Weather Information System

Operational Manual



1	General information.....	5
1.1	<i>Safety information.....</i>	5
1.1.1	Safety information	6
1.1.2	Precautionary labels	7
1.1.3	Chemical and biological safety	8
1.1.4	FCC Statements	8
2	Road Weather Information Systems - Product Overview.....	9
2.1	<i>Typical RWIS Components</i>	10
2.1.1	Communication / Data Transmission.....	10
2.2	<i>System Wiring Diagram – Communication & Power Flow – Typical RWIS Lite</i>	11
2.3	<i>Data Loggers / Cell pro-Router Transmitter</i>	11
2.3.1	LCOM Communicator Datalogger & Controller	11
2.3.1.1	Power Supply Port	13
2.3.1.2	Operation	13
2.3.1.3	GPRS Modem Connection for Wireless TCP/IP Connections, and Analog Modem for PPP-Dial in Connections.	13
2.3.1.4	UMB Connection Terminals	14
2.3.1.5	Ethernet Port.....	14
2.3.1.6	USB Port.....	14
2.3.1.7	Pin Assignment CON220-1 and CON220-2.....	15
2.4	<i>NIRS31 non-invasive road weather Sensor</i>	15
2.5	<i>WS600-UMB Smart Weather Sensor</i>	18
2.6	<i>RV55 Cell Pro-Router Transmitter</i>	19
2.6.1	Process and Meta Data	21
2.7	<i>Power Supply L8366.USV2 TRIO-PS/1AC/24DC/10.....</i>	22
2.8	<i>UMB Interface Converter ISOCON-UMB</i>	23
2.9	<i>SURGE PROTECTION UMB.....</i>	25
2.10	<i>Instrumentation Towers</i>	27
2.11	<i>2J Antennas Saltshaker Antenna - LL100 Cables</i>	28
2.12	<i>Enclosures & Back Panel</i>	29
2.13	<i>Station Wiring.....</i>	31
2.14	<i>Power Distribution.....</i>	32
2.14.2	Cables	32
2.14.3	Terminals	33
2.14.4	Fuse	33
2.14.5	The Surge Protection Device (SPD).....	33
3	Installation	35
	General.....	35
3.1	<i>Mechanical Installation</i>	36
3.1.1	Towers.....	36
3.1.1.1	Safety Guidelines for Erection of the Towers	36
3.1.1.2	Typical Tower Erection	38
3.1.1.3	Base and Guy Anchor Layout	40
3.1.1.4	Tower base installation.....	41
3.1.2	Ultrasonic Wind Speed Mounting	45
3.1.3	Enclosures.....	46

3.1.4	Enclosure Mounting	48
3.2	<i>Electrical Installation</i>	50
3.2.1	Electrostatic discharge (ESD) considerations	50
3.2.2	Grounding.....	51
3.2.3	Earth Grounding of Electrical Enclosure	51
4	Maintenance	55
4.1	<i>Installation Site</i>	55
4.2	<i>Structure</i>	55
4.3	<i>Electrical</i>	55
4.4	<i>Equipment</i>	55
4.4.1	Enclosure	55
4.4.2	LCOM Communicator Datalogger	56
4.4.3	NIRS31 non-invasive road weather Sensor	56
4.4.4	WS600-UMB Smart Weather Sensor.....	56
4.4.5	Weather Considerations	57

Figure 1.	Example of RWIS in the field	9
Figure 2.	Example of RWIS in the field	9
Figure 3.	Inside of RWIS enclosure	10
Figure 4.	Example of a typical RWIS wiring diagram.....	11
Figure 5.	Lufft LCOM Datalogger (Front view)	11
Figure 6.	Lufft LCOM Datalogger ports (Side view).....	12
Figure 7.	Lufft LCOM Datalogger Specifications.....	12
Figure 8.	LCOM/GPRS Modem pinout wiring.....	14
Figure 9.	LCOM/Internal UMB bus pinout wiring.....	14
Figure 10.	Pin assignment for CON220-1	15
Figure 11.	Pin assignment for CON220-2	15
Figure 12.	NIRS31 Sensor.....	16
Figure 13.	ISOCON-UMB	24
Figure 14.	ISOCON-UMB pinout wiring.....	24
Figure 15.	UMB Surge protector	25
Figure 16.	UMB Surge protector specifications	26
Figure 17.	Salt Shaker antenna.....	28
Figure 18.	Salt Shaker antenna specifications.....	28
Figure 19.	Salt Shaker antenna specifications cont.....	29
Figure 20.	Inside of enclosure	29
Figure 21.	Glands on enclosure.....	30
Figure 22.	LCOM/ISOCON/Power supply wiring.....	31
Figure 23.	Examples of surge protectors in RWIS systems.....	34
Figure 24.	Examples of surge protectors in RWIS systems cont.	34
Figure 25.	Example of a tower with a cautionary sign	36
Figure 26.	RWIS tower in the field.....	38
Figure 27.	RWIS tower diagram.....	39
Figure 28.	Tower base diagram.....	40
Figure 29.	Examples of proper tower installation.....	42
Figure 30.	Examples of proper tower installation cont.....	42
Figure 31.	Each section of the tower is secured to the previous section using three bolts.....	43
Figure 32.	Guy wire is attached to the tower using clamps	43
Figure 33.	Guy wire is attached to the turnbuckle.....	44
Figure 34.	Ultrasonic wind speed mounting diagram	45
Figure 35.	Ultrasonic wind speed mounting diagram cont.	45
Figure 36.	Enclosure diagram.....	46
Figure 37.	Enclosure diagram cont	46
Figure 38.	Enclosure diagram cont	47
Figure 39.	Enclosure diagram cont	47
Figure 40.	Diagram for mounting enclosures to pole.....	48
Figure 41.	Mounted enclosure in the field.....	49
Figure 42.	Example of glands on the enclosure	54

1 General information

In no event will the manufacturer be liable for direct, indirect, special, incidental, or consequential damages resulting from any defect or omission in this manual. The manufacturer reserves the right to make changes in this manual and the products it describes at any time, without notice or obligation. Revised editions are found on the manufacturer's website.

For recycling, please contact the equipment producer or supplier for instructions on how to return end-of-life equipment, producer-supplied electrical accessories, and all auxiliary items for proper disposal. No equipment is to be returned without authorization. Local recycling programs may be used. For the manufacturer recycling programs or producer-supplied electrical accessories and auxiliary items, contact the equipment supplier for proper disposal instructions. Connect equipment in accordance with local state or national electrical codes.

1.1 Safety information

NOTICE

The manufacturer is not responsible for any damages due to misapplication or misuse of this product including, without limitation, direct, incidental and consequential damages, and disclaims such damages to the full extent permitted under applicable law. The user is solely responsible to identify critical application risks and install appropriate mechanisms to protect processes during a possible equipment malfunction.

Please read this 'Installation Manual for the Weather Station' and every single Manual from the used Products in this System before unpacking, setting up or operating this equipment. Pay attention to all danger and caution statements. Failure to do so could result in serious injury to the operator or damage to the equipment. Make sure that the protection provided by this equipment is not impaired. Do not use or install this equipment in any manner other than that specified in this manual.

1.1.1 Safety information

DANGER

Indicates a potentially or imminently hazardous situation which, if not avoided, will result in death or serious injury.

WARNING

Indicates a potentially or imminently hazardous situation which, if not avoided, could result in death or serious injury.

CAUTION

















Indicates a potentially hazardous situation that may result in minor or moderate injury.

NOTICE

Indicates a situation which, if not avoided, may cause damage to the instrument.
Information that requires special emphasis.

1.1.2 Precautionary labels

Read all labels and tags attached to the instrument. Personal injury or damage to the instrument could occur if not observed. A symbol on the instrument is referenced in the manual with a precautionary statement.

	This is the safety alert symbol. Obey all safety messages that follow this symbol to avoid potential injury. If on the instrument, refer to the instruction manual for operation or safety information.
	This symbol indicates the need for protective eye wear.
	This symbol indicates that a risk of electrical shock and/or electrocution exists.
	This symbol indicates that the marked item can be hot and should not be touched without care.
	This symbol indicates that a risk of fire is present.
	This symbol identifies the presence of a strong corrosive or other hazardous substance and a risk of chemical harm. Only individuals qualified and trained to work with chemicals should handle chemicals or perform maintenance on chemical delivery systems associated with the equipment.
	This symbol indicates the presence of a harmful irritant.
	This symbol indicates that the marked item should not be touched.
	This symbol indicates a potential pinch hazard.
	This symbol indicates that the object is heavy.
	This symbol indicates the presence of devices sensitive to Electro-static Discharge (ESD) and indicates that care must be taken to prevent damage with the equipment.
	This symbol indicates that the marked item requires a protective earth connection. If the instrument is not supplied with a ground plug on a cord, make the protective earth connection to the protective conductor terminal.
	Electrical equipment marked with this symbol may not be disposed of in European domestic or public disposal systems. Return old or end-of-life equipment to the manufacturer for disposal at no charge to the user.
	Explosion hazard. Do not connect or disconnect electrical components or circuits to the equipment unless power has been removed or the area is known to be non-hazardous.
	This symbol represents hazardous areas that require PPE and personnel granted permission to access.
	This symbol represents the requirement for a safety harness, while climbing and accessing mounted equipment.

1.1.3 Chemical and biological safety



DANGER

Chemical or biological hazards. If this instrument is used to monitor a treatment process and/or chemical feed system for which there are regulatory limits and monitoring requirements related to public health, public safety, food or beverage manufacture or processing, it is the responsibility of the user of this instrument to know and abide by any applicable regulation and to have sufficient and appropriate mechanisms in place for compliance with applicable regulations in the event of malfunction of the instrument.

1.1.4 FCC Statements

FCC statement for unintentional radiators

Note: This equipment has been tested and found to comply with the limits for a Class A digital device, pursuant to part 15 of the FCC Rules. These limits are designed to provide reasonable protection against harmful interference when the equipment is operated in a commercial environment. This equipment generates, uses, and can radiate radio frequency energy and, if not installed and used in accordance with the instruction manual, may cause harmful interference to radio communications. Operation of this equipment in a residential area is likely to cause harmful interference in which case the user will be required to correct the interference at his own expense. The FCC ID#: N7NMC7355 & IC#: N2417C - MC7355.

FCC statement for intentional radiators

Warning: Unauthorized modification or changes to this wireless communication equipment will void the right to use it. Changes or modifications to this unit not expressly approved by the party responsible for compliance will void the user's authority to operate the equipment. Any change to the equipment will void the Industry Canada certification and FCC grant.

2 Road Weather Information Systems - Product Overview

Road Weather Information Systems (RWIS) provide an integrated system of components that are used to measure, monitor, study, and ensure availability of essential weather and road surface information. Keeping roads and highways safe is critically important. In addition to seasonal perils, the increase of weather fluctuations and extreme weather events throughout the year pose further challenges to road decision-makers.

Road Weather Information System (RWIS) consists of towers, poles, rugged lockable aluminum enclosure with mounting accessories, power supply, on site surge, ISOCON-UMB converter, surge protection-UMB. Additionally, the RWIS includes the LCOM-Luft communicator datalogger for collecting measurements from sensors on a regular interval and communicating remotely via the RV55 4G LTE cell Pro-router. The LCOM datalogger is preconfigured for use with non-invasive NIRS31 sensor and WS600-UMB smart weather sensor (SWS). This factory pre-configuration and testing of the RWIS stations offer a high-quality plug and play of the components.



Figure 1. Example of RWIS in the field



Figure 2. Example of RWIS in the field

2.1 Typical RWIS Components

A Typical RWIS system will consist of the Following

1. LCOM Communicator Datalogger
2. Sensors
 - a) NIRS31 non-invasive road weather sensor with 30 meters cable & mounting bracket
 - b) WS600-UMB Smart Weather Sensor with 20 meters cable & WS mounting bracket
3. RV55 4G LTE cell Pro-router
4. Power supply (Battery, Charger, and Solar Panel)
5. ISOCON-UMB converter
6. Surge protection UMB
7. Surge protection
8. NEMA-4X enclosure with Aluminum back panel, DIN rail and mounting hardware
9. RWIS station wiring diagram



Figure 3. Inside of RWIS enclosure

The LCOM Datalogger, the RV55 4G LTE cell Pro-router transmitter, the ISOCON-UMB converter, the power supply, the surge protection will be housed on the aluminum back panel's DIN rail inside the NEMA-4X enclosure. The NIRS31 and WS600 Sensors and NEMA-4X enclosure will be mounted on RWIS tower or pole.

2.1.1 Communication / Data Transmission

The data transmission to a remote base station, running the software ViewMondo, is implemented via a RV55 4G LTE cell Pro-router. The cell pro-router is factory configured for port forwarding for remote access of the LCOM, maintenance and troubleshooting.

2.2 System Wiring Diagram – Communication & Power Flow – Typical RWIS Lite

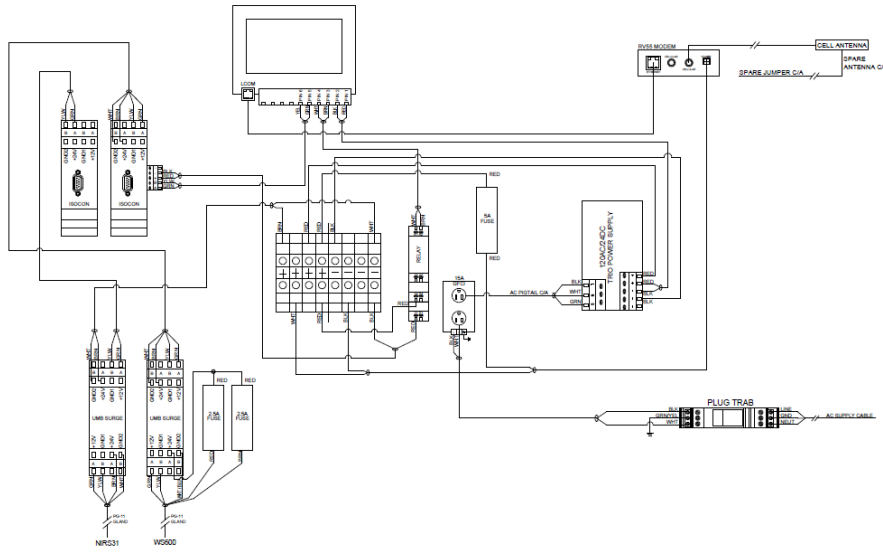

Figure 4. Example of a typical RWIS wiring diagram



DANGER

Electrocution hazard. Always remove power to the instrument before making electrical connections.

2.3 Data Loggers / Cell pro-Router Transmitter

2.3.1 LCOM Communicator Datalogger & Controller

Please Read Before Use

Before using the equipment, please read the operating manual carefully and follow the instructions in every detail.

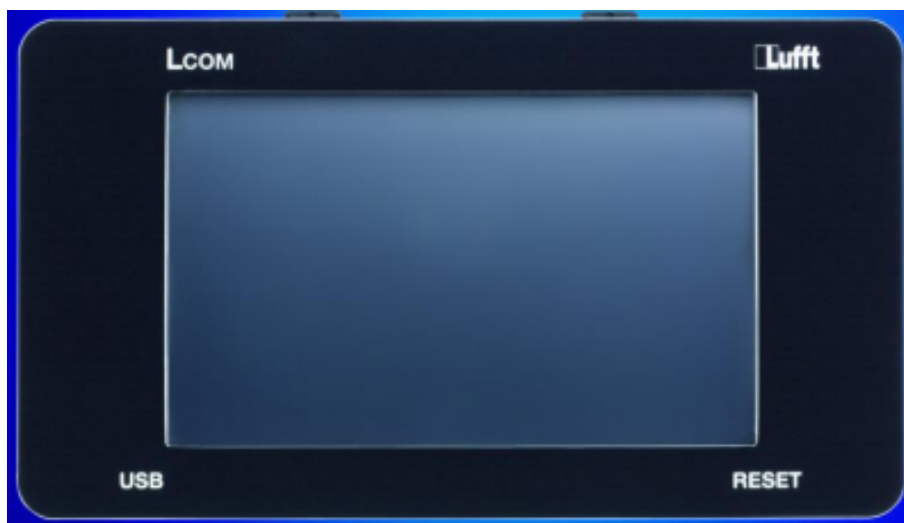

Figure 5. Lufft LCOM Datalogger (Front view)

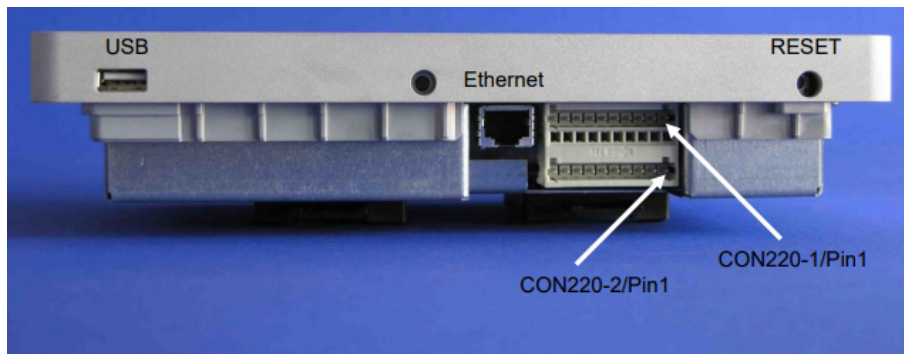

Figure 6. Lufft LCOM Datalogger ports (Side view)

General

Operating conditions

Power supply	10 ... 28 VDC
Power consumption	10 VA
Ambient temperature	-25...70°C
Relative humidity	<90 % RH
Protection type	IP20
Dimensions	230 x 130 x 50 mm
USB interface	USB2.0B
GPRS modem interface	RS232 on Wago Cage Clamp
Partyline modem interface	RS232 on Wago Cage Clamp
UMB bus interface	RS485 on Wago Cage Clamp
Display size	7 inch
Display resolution	800 x 480 pixel

Storage conditions

Ambient temperature	-25...70°C
Relative humidity	<95 % RH

Figure 7. Lufft LCOM Datalogger Specifications

The introduction of UMB technology has enabled Lufft to offer low-cost sensors for road traffic technology. UMB sensors can be combined using ISOCON modules. Additional analog sensors can be integrated using the ANACON module. The LCom, or Lufft Communicator, was developed to provide the UMB sensor data over various communication protocols. LCom consists of an embedded computer with Windows CE operating system, a touchscreen display (resolution 800x480 pixels and CFL backlighting), interfaces for a GPRS modem, party-Line modem, and UMB network, ethernet, and USB interface. In addition, LCom has a real-time clock with battery backup. Currently following protocols are supported:

- TLS97
- TLS2002
- TLS2012
- TLS over IP (Asfinag)
- NTCIP (via SNMP)
- MSSSI (SOAP) (Lufft/Asfinag)
- DGT (Spain)

In TLS mode, LCom operates as an 'integrated control module with EAK' (Inselbus), or as 'EAK on external control module' (Lokalbus).

2.3.1.1 Power Supply Port

LCom is powered via the UB+ and GND ports (according to the CON220-1 wiring. See figure 10) on the UMB-EAK. The allowed voltage range is 10VDC to 28VDC. The input is protected against reverse polarity, surge, and burst. Power supply for the GPRS modem (ports GUB_2 and GND) and Party-Line modem (ports GUB_3 and GND) are provided on connector CON220-1 (Fig. 10). Depending on the status of the modem, LCom can switch these two voltages on and off to reset the respective modem. The power supply for the UMB network (ports GUB1 and GND) is available on CON220-1. The maximum output current is 4 amp. If higher currents are required, the sensor heater tapes must be powered and protected separately.

All output voltages are short-cut proof.

2.3.1.2 Operation

The standard functions of the LCom can conveniently be used via the touch screen display. For configuration purposes, we recommend the connection of a PC keyboard with USB connection or connecting a PC/Laptop via LAN and using the service program.

2.3.1.3 GPRS Modem Connection for Wireless TCP/IP Connections, and Analog Modem for PPP-Dial in Connections.

The supported modem for GPRS Connections is Wavecom Fastrack GPRS Modem. Serial port settings are 115200 baud, 8 data bits, no parity, 1 stop bit, and RTS/CTS hardware handshake enabled.

Alternative modems can be tested on request.

LCom	Connection	GPRS Modem
RXD1 (CON220-1/Pin 7)	RS232	RXD (Pin 6)
TXD1 (CON220-1/Pin 8)	RS232	TXD (Pin 2)
RTS1 (CON220-1/Pin 9)	RS232	RTS (Pin 12)
CTS1 (CON220-1/Pin 10)	RS232	CTS (Pin 11)
GND (CON220-2/Pin 2)	RS232 (if required)	GND
GUB_2 (CON220-2/Pin 1)	Power supply	UB+ - 1V
GND (CON220-2/Pin 2)	Power supply	GND

Figure 8. LCOM/GPRS Modem pinout wiring

For the PPP Dial in Connection, any Hayes compatible modem may be used. Serial port settings are 57600 baud, 8 data bits, no parity, 1 stop bit, and RTS/CTS hardware handshake enabled.

2.3.1.4 UMB Connection Terminals

The data connection and power supply are provided over the UMB connection. Please note that the maximum current on the LCom's power supply output is 4 amp. If higher currents are required, the sensor heater must be powered and protected separately.

Interface settings: 19200 baud, 8 data bits, no parity, and 1 stop bit.

LCom	Connection	UMB Connection (internal bus)
A (CON220-1/Pin 5)	-----	A1
B (CON220-1/Pin 6)	-----	B1
GUB_1 (CON220-1/Pin 3)	-----	UB+ - 1V
GND (CON220-1/Pin 4)	-----	GND

Figure 9. LCOM/Internal UMB bus pinout wiring

2.3.1.5 Ethernet Port

10/100 Mbit with TCP/IP stack

IP address: 192.168.0.50

Net mask: 255.255.255.0

Standard gateway: -

All settings can be changed in Windows CE control panel.

2.3.1.6 USB Port

A USB hub, keyboard, mouse and memory stick can be connected to the USB interface.

2.3.1.7 Pin Assignment CON220-1 and CON220-2

Pin	Name	Comment
1	UB+	Positive power supply of EAK, 10V... 28V
2	GND	Ground
3	GUB_1	Switched UMB power supply
4	GND	Ground
5	A	A-RS485 for UMB communication
6	B	B-RS485 for UMB communication
7	RXD1	GPRS or Analog modem connection, Receive line
8	TXD1	GPRS or Analog modem connection, Transmit line
9	RTS1	GPRS or Analog modem connection, Ready to send
10	CTS1	GPRS or Analog modem connection, Clear to send

Figure 10. Pin assignment for CON220-1

Pin	Name	Comment
1	GUB_2	Switched power supply for GPRS or Analog modem
2	GND	Ground
3	GUB_3	Switched power supply for TLS/Party Line modem (or Camera, see Camera configuration)
4	GND	Ground
5	RXD_MOD	Data modem connection (TLS/Party Line), or Opus200 Receive Data, Input
6	TXD_MOD	Data modem connection (TLS/Party Line), or Opus200 Transmit Data, Output
7	RTS_MOD	Data modem connection (TLS/Party Line), or Opus200 Ready to send, Output
8	DTR_MOD	Data modem connection (TLS/Party Line), Data terminal ready, Output
9	CTS_MOD	Data modem connection (TLS/Party Line), or Opus200 Clear to send, Input
10	DCD_MOD	Data modem connection (TLS/Party Line), Data carrier detect, Input

Figure 11. Pin assignment for CON220-2

2.4 NIRS31 non-invasive road weather Sensor

Please Read Before Use

Please read the operating manual for this sensor (www.lufft.com) carefully and keep it handy for future reference. Please note that various components of the sensor and the described software may look somewhat different from those shown in the illustrations in this operating manual.

The device version is indicated as the last number of the serial number printed on the type plate, e.g.: the device with SN: 063.1010.0707.014 has the device version 14.

Safety Instructions

- Installation and commissioning must only be carried out by suitably qualified specialist personnel.
- Never take measurements on or touch live electrical parts.
- Pay attention to the technical data and storage and operating conditions.

Designated Use

- The equipment must only be operated within the range of the specified technical data.
- The equipment must only be used under the conditions and for the purposes for which it was designed.
- The safety and operation of the equipment can no longer be guaranteed if it is modified or adapted.

Incorrect Use

If the equipment is not correctly installed:

- It may not function, or its operation may be limited.
- It may be permanently damaged.
- Danger of injury may exist if the equipment is allowed to fall.

If the equipment is not correctly connected:

- It may not function.
- It may be permanently damaged.
- The possibility of an electrical shock may exist under certain circumstances.

Guarantee

The guarantee period is 24 months from the date of delivery. The guarantee is forfeited if the designated use is violated.

Brand Names

All brand names referred to are subject without limitation to the valid trademark and ownership rights of the respective owner.

Primary / Secondary (Client / Server) Terminology

In this documentation, the terminology primary / secondary (ISC) is used to describe communication processes.

The NIRS31-UMB is a non-invasive road weather sensor with optical principle. It is mounted several meters above the ground and can even monitor bridges. The NIRS31-UMB road weather sensor works with optical principle and is mounted several meters above the surface at bridges or masts. It measures surface conditions such as wetness, ice, snow, frost, water film heights, ice percentage in water, and freeze point temperature. Through these measurements it generates the friction coefficient on the road or runway.



Figure 12. NIRS31 Sensor

General	
Dimensions	H. ca. 425 mm, W. ca. 225mm, D. ca. 285mm
Weight	10 kg
Storage conditions	
Permissible ambient temperature	-40...70°C
Permissible relative humidity	0 ... 95% R.H. non-condensing
Operating conditions	
Permissible relative humidity	0 ... 100% R.H.
Operating voltage	24 VDC ±10%
Power consumption	Approx. 40VA
Operating temperature	-40...60°C
Protection type	IP65
Layer thickness	
Layer thickness	Water, Snow, Ice
Principle	Optical
Measuring range	0...2mm (snow 0 ... 10 mm)
Resolution	0.01mm
Surface conditions	
Surface conditions	Dry, Damp, Wet, Snow, Ice
Friction	
Friction	Measurement range 0...1 (critical ... dry)
Road surface temperature	
Principle	Pyrometer
Measuring range	-40 bis +70°C
Accuracy	0,8°C
Resolution	0,1°C
Saline Concentration	
Measurement process	Spectroscopic
Measuring range	0% ... 100%
Resolution	0.1%
Sampling rate	<1 minute
Units	%

Figure 13. NIRS31 Specifications

2.5 WS600-UMB Smart Weather Sensor

The Lufft WS600 is a compact all-in-one weather sensor that can measure temperature, relative humidity, precipitation intensity, precipitation type, precipitation quantity, air pressure, wind direction and wind speed.

General	
Dimensions	Ø approx. 150 mm, height approx. 343 mm
Weight	Approx. 1.5 kg
Interface	RS485, 2 - wire, half - duplex
Power supply	11 ... 32 VDC
Power supply	5 ... 11 VDC (electronics with limited precision of measurements)
Power supply	24 VDC +/- 10% (heater)
Power consumption	40 VA (heater)
Operating temperature	-50...60 °C (with heater)
Operating rel. humidity	0...100 % RH
Cable length	10 m
Protection Level housing	IP66
Standards/Regulations	Compliant to IEC 61724-1:2017
Mounting suitable for	Mount diameter 60 - 76 mm
Temperature	
Principle	NTC
Measuring range	-50 ... 60 °C
Unit	°C
Accuracy	±0.2 °C (-20...50 °C), otherwise ±0.5 °C (>-30 °C)
Relative humidity	
Principle	Capacitive
Measuring range	0 ... 100 % RH
Unit	% RH
Accuracy	±2 % RH
Air pressure	
Principle	MEMS capacitive
Measuring range	300 ... 1200 hPa
Unit	hPa
Accuracy	±0.5 hPa (0...40 °C)
Wind direction	
Principle	Ultrasonic
Measuring range	0 ... 359.9 °

Figure 14. WS600 Specifications

Unit	°
Accuracy	< 3 ° RMSE > 1.0 m/s
Resolution	0.1
Wind speed	
Principle	Ultrasonic
Measuring range	0 ... 75 m/s
Unit	m/s
Accuracy	±0.3 m/s or ±3 % (0...35 m/s) ±5 % (>35 m/s) RMS
Resolution	0.1 m/s
Precipitation (liquid)	
Droplet size	0,3 ... 5 mm
Detection sensitivity	0,01 mm/h
Particle velocity	0.9 ... 15.5 m/s
Precipitation types	rain/ snow
Solid precipitation	5.1 ... ~30 mm
Intensity range	0.5 ... 200mm/h
Intensity resolution	0.01 mm/h
Amount resolution	0.1 mm
Accuracy	20 % under laboratory conditions
Reproducibility	Typical >90 % under laboratory conditions

Figure 15. WS600 Specifications cont.

2.6 RV55 Cell Pro-Router Transmitter



Figure 16. RV55 Cell Pro-Router Transmitter (Front view)



Figure 17. RV55 Cell Pro-Router Transmitter (Back view)

The RV55 high-performance LTE-Advanced Pro connectivity modem offers Wi-Fi and GNSS and location-based applications and dual connectivity for vehicle fleets and mobile workforce. An LTE-M/NB-IoT variant is perfectly suited for hard-to-reach conditions. The RV55 supports an extensive range of LTE bands worldwide, and its LTEAdvanced Pro capabilities deliver up to 600 Mbps downlink speeds. The RV55 also supports new unlicensed LTE bands (e.g. CBRS) to support dedicated Private LTE service. The RV55 Regulatory Carrier is FCC, IC, PTCRB for North America and FCC, IC, PTCRB, GCF, CE, RCM globally. The FCC ID#: N7NMC7355 & IC#:N2417C - MC7355.

	North America	EMEA	North America	Global	Global
	LTE		LTE-A Pro		LTE-M/ NB-IoT
LTE CATEGORY	Cat 4 (WP7610/WP7607)		Cat 12 (EM7511/EM7565)		Cat M1/NB1 (WP7702)
Peak D/L	Up to 150 Mbps		Up to 600 Mbps		Cat-M1: 300kbps Cat-NB1: 27kbps
Peak U/L	Up to 50 Mbps		Up to 150 Mbps		Cat-M1: 375kbps Cat-NB1: 65kbps
4G LTE Frequency Bands	1900(B2), AWS(B4), 850(B5), 700(B12), 700(B13), 700(B17), 1700(B66)	2100(B1), 1800(B3), 2600(B7), 900(B8), 800(B20), 700(B28)	2100(B1), 1900(B2), 1800(B3), AWS(B4), 850(B5), 2600(B7), 900(B8), 1800(B9), 700(B12), 700(B13), 700(B14), 850(B18), 850(B19), 800(B20), 850(B26), 700(B29), 2300(B30), 1500(B32), TDD B41, TDD B42, TDD B43, TDD B46, CBRS B48,1700(B66)	2100(B1), 1900(B2), 1800(B3), AWS(B4), 850(B5), 2600(B7), 900(B8), 1800(B9), 700(B12), 700(B13), 850(B18), 850(B19), 800(B20), 850(B26), 700(B29), 2300(B30), 1500(B32), TDD B41, TDD B42, TDD B43, TDD B46, CBRS B48, 1700(B66)	2100(B1), 1900(B2), 1800(B3), AWS(B4), 850(B5), 900(B8), 700(B12), 850(B5), 900(B8), 700(B12), 700(B13), 700(B17), 850(B18), 850(B19), 800(B20), 850(B26), 700(B28)
3G HSPA/HSPA+ Frequency Bands*	1900(B2), AWS(B4), 850(B5)	2100(B1), 900(B8)	2100(B1), 1900(B2), AWS(B4), 850(B5), 800(B6), 900(B8), 1700(B9), 850(B19)	2100(B1), 1900(B2), AWS(B4), 850(B5), 800(B6), 900(B8), 1700(B9), 850(B19)	
2G EDGE/GSM/GPRS Frequency Bands		900, 1800			850, 900, 1800, 1900
APPROVALS Regulatory	FCC, IC, PTCRB	GCF, CE	FCC, IC, PTCRB	FCC, IC, PTCRB, GCF, CE, RCM, IFT, Anatel	FCC, IC, PTCRB, GCF, CE, RCM
Carrier	Verizon, AT&T		Verizon, AT&T/FirstNet, US Cellular, Sprint, Telus	Verizon, AT&T, Telstra(Planned)	Verizon(Cat-M), AT&T(Cat-M)
PART NUMBER Regulatory	1104335	1104337	1104303, 1104302 (Wi-Fi) 1104302 (Wi-Fi)	1104332, 1104331 (Wi-Fi) 1104331 (Wi-Fi)	1104333

*For carrier-specific band support please refer to the hardware user guide.

	Specification	Specification
HOST INTERFACES	10/100/1000 Ethernet (RJ45) RS-232 serial port (DB-9) USB 2.0 Micro-B Connector 3 SMA antenna (cellular, diversity, GNSS) 2 RP-SMA antenna (1x1 Wi-Fi, Optional) LTE-M/NB-IoT: 1 SMA (cellular) only, no GNSS or Wi-Fi Active GPS antenna support	SATELLITE NAVIGATION (GNSS) LTE-A Pro Variant: 30 Channel GPS and GLONASS Receiver (Tracking Sensitivity: -160dBm) LTE Variant: 48 Channel Dedicated GNSS Receiver (Tracking Sensitivity: -162 dBm) Accuracy: <2 m (50%), <5 m (90%), <0.2 m/s Acquisition Time: 1s Hot Start Reports: NMEA 0183 V3.0, TAIP, RAP, XORA Multiple Redundant Servers Reliable Store and Forward
Wi-Fi (Optional)	Dual Band 2.4/5GHz Wi-Fi Dual Radio, 802.11 b/g/n/ac (Wave2 Client Mode) Support for 10 clients, WPA2 Enterprise per radio Output power 16dBm Configurable as Dual Band Access Point (AP) or AP+Client Mode Single SSID Support per radio Captive Portal	SECURITY Remote Authentication (LDAP, RADIUS, TACACS+, DMZ) Inbound and Outbound Port Filtering Inbound and Outbound Trusted IP MAC Address Filtering PCI compatible Secure Firmware Update

Figure 18. RV55 Specifications

	Specification		Specification
INPUT/OUTPUT	Configurable I/O pin on power connector <ul style="list-style-type: none"> Digital Input ON Voltage: 2.7 to 36 VDC Configurable Pull-up for dry contact input Digital Open Collector Output > sinking 500 mA Analog Input: 0.5-36 VDC 	NETWORK MANAGEMENT	Secure mobile network & asset management application available in the cloud or licensed platform in the enterprise data center <ul style="list-style-type: none"> Fleet wide Firmware upgrade delivery Router configuration and template management Router staging over the air and local Ethernet connection Over-the-air software and radio module firmware updates Device Configuration Templates Configurable monitoring and alerting Remote provisioning and airtime activation (where applicable)
LAN (ETHERNET/USB)	DHCP Server IP Passthrough VLAN	Host Interface Watchdog PPPoE	
SERIAL	TCP/UDP PAD Mode Modbus (ASCII, RTU, Variable) PPP DNP3 Interoperability Dual Serial option (with an accessory)		
NETWORK AND ROUTING	Network Address Translation (NAT) Port Forwarding Policy Routing NEMO/DMNR VRRP	Reliable Static Route Dynamic DNS Verizon PNTM IPv6 Gateway	
VPN	IPsec, GRE, and OpenVPN Client Up to 5 concurrent tunnels Split Tunnel Dead Peer Detection (DPD) FIPS 140-2 compatible		
APPLICATION FRAMEWORK	ALEOS Application Framework (AAF) Lua Scripting Language		
POWER	Input Voltage: 7 to 36 VDC LTE Idle Power: 900mW (75 mA @ 12VDC) Standby Mode Power: 53 mW (4.4 mA @ 12 VDC) triggered on low voltage, I/O or periodic timer Low voltage disconnect to prevent battery drain Built-in protection against voltage transients including 5 VDC engine cranking and +200 VDC load dump Ignition Sense with time delay shutdown Configurable features and ports to optimize power consumption		
DIMENSIONS	119 mm x 33 mm x 85 mm (102 mm including wi-fi connectors) 4.69 in x 1.34 in x 3.35 in (3.70 in including connectors) Weight: 320 g		
			
		ROUTER MANAGEMENT	ALMS Local web user interface AT Command Line Interface (Telnet/SSH/Serial) SMS Commands SNMP
		EVENTS ENGINE	Custom event triggers and reports Configurable interface, no programming Event Types: Digital Input, Network Parameters, Data Usage, Timer, Power, Device Temperature and Voltage Report Types: RAP, SMS, Email, SNMP Trap, TCP (Binary, XML, CSV) Event Actions: Drive Relay Output
		ENVIRONMENTAL	Operating Temperature: -40°C to +70°C / -40°F to +158°F Operating Temperature (Wi-Fi variant): -30°C to +70°C / -22°F to +158°F Storage Temperature: -40°C to +85°C / -40°F to +185°F Humidity: 95% RH @ 60°C Military Spec MIL-STD-810G conformance to shock, vibration, thermal shock, and humidity IP64 rated ingress protection
		INDUSTRY CERTIFICATIONS	Safety: IECCE Certification Bodies Scheme (CB Scheme), UL 60950** Vehicle Usage: E-Mark (UN ECE Regulation 10.04), Rail Usage: EN50155 ISO7637-2, SAE J1455 (Shock & Vibration) Hazardous Environments: Class 1 Div 2 - Ambient temperatures of -30°C to +60°C Environmental: RoHS, REACH, WEEE
		SUPPORT AND WARRANTY	Includes 1st Year AirLink Complete: <ul style="list-style-type: none"> AirLink Management Service (ALMS) Direct 24/7 Technical Support 3-year standard warranty, optional 2-year warranty extension 1-day Accelerated Hardware Replacement available through participating resellers
		ACCESSORIES	In the Box: DC Power Cable, and Quick Start Guide Other Accessories (sold separately): 2000579 AC Adapter, 12VDC 6000659 DIN Rail Bracket For Antenna options visit: sierrawireless.com/antennas
			** Ambient temperatures of -30C to +60C

Figure 19. RV55 Specifications cont.

2.6.1 Process and Meta Data

Data transmission follows the process below.

- Retrieve raw data output from sensors
- Data processing in the NTCIP
- Value mapping or scaling
- Alarm processing
- Use quality control parameters
- Formatting of output data

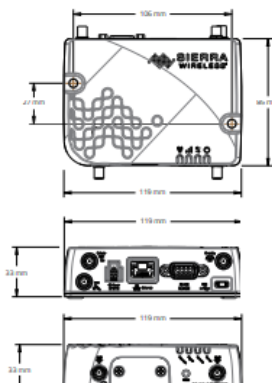
2.7 Power Supply L8366.USV2 TRIO-PS/1AC/24DC/10



Figure 20. Phoenix Contact power supply

Input data

AC operation	
Nominal input voltage range	100 V AC ... 240 V AC
Input voltage range	85 V AC ... 264 V AC (Derating < 90 V AC: 2.5 %/V)
Derating	< 90 V AC (2.5 %/V)
Input voltage range AC	85 V AC ... 264 V AC (Derating < 90 V AC: 2.5 %/V)
Electric strength, max.	300 V AC
Voltage type of supply voltage	AC
Inrush current	< 15 A
Inrush current integral (I^2t)	0.7 A ² s
AC frequency range	45 Hz ... 65 Hz
Mains buffering time	> 24 ms (120 V AC) > 24 ms (230 V AC)
Current consumption	3 A (100 V AC) 1.5 A (240 V AC)
Nominal power consumption	272 VA
Protective circuit	Transient surge protection; Varistor
Power factor (cos phi)	0.99
Typical response time	< 1 s
Input fuse	6.3 A (slow-blow, internal)
Permissible backup fuse	B10 B16
Recommended breaker for input protection	10 A ... 16 A (Characteristics B, C, D, K)
Discharge current to PE	< 3.5 mA

Figure 21. Power supply specifications

Output data

Efficiency	89 % (for 230 V AC and nominal values)
Output characteristic	U/I
Nominal output voltage	24 V DC \pm 1 %
Setting range of the output voltage (U_{Set})	22.5 V DC ... 29.5 V DC (> 24 V DC, constant capacity restricted)
Nominal output current (I_N)	10 A (U_{OUT} = 24 V DC)
Derating	55 °C ... 70 °C (2.5 %/K)
Feedback voltage resistance	35 V DC
Protection against overvoltage at the output (OVP)	< 35 V DC
Max. capacitive load	unlimited
Active current limitation	Approx. 14 A (for short-circuit)
Control deviation	< 1 % (change in load, static 10 % ... 90 %) < 2 % (change in load, dynamic 10 % ... 90 %) < 0.1 % (change in input voltage \pm 10 %)
Residual ripple	< 10 mV _{PP}
Output power	240 W
Peak switching voltages nominal load	< 50 mV _{PP}

Figure 22. Power supply specifications cont.

2.8 UMB Interface Converter ISOCON-UMB

Please read before use

Before using the equipment, please read the operating manual carefully and follow the instructions in every detail.

Safety instructions

- Installation and commissioning must only be carried out by suitably qualified specialist personnel.
- Never take measurements on or touch live electrical parts.
- Only mount the module on the DIN rail when the power is switched off.
- Protect the device from direct sunlight
- The equipment requires an adjustment period of several minutes on being moved to a location with different climate conditions.
- Pay attention to the technical data and storage and operating conditions.



Designated use

- The equipment must only be operated within the range of the specified technical data.
- The equipment must only be used under the conditions and for the purposes for which it was designed.
- The safety and operation of the equipment can no longer be guaranteed if it is modified or adapted.

Guarantee

The guarantee period is 24 months from the date of delivery. The guarantee is forfeited if the designated use is violated.

ISOCON-UMB communication module for all UMB sensors with

- Communication-watchdog for reliable sensor function (reset)
- Galvanic isolation
- LED indication for operation mode

The ISOCON-UMB converts RS-485 into RS232. By installing several ISOCONs connected to a sensor on a standard top-hat rail, the connected sensors can be networked easily.

- Interfaces: RS-485
- Article number: 8160.UISO



Figure 13. ISOCON-UMB

Technical Data

Power supply

Power supply	24VDC +/- 10%
Power consumption	< 50mA at 24V; excluding sensor
Connection	Phoenix bus connector, gold, 5 pole
Function display	Green LED, flashes every 10 seconds

RS232 interface

Transmission type	Protocol-transparent, 8 data bits, 1 stop bit, no parity
Configuration	DIP switch
Transmission rates	1200, 2400, 4800, 9600, 19200, 38400, 57600 baud
Transmission length	0 ... 15 m, from 38400 baud max. 5 m recommended
Connection	9 pole SUB-D socket

RS485 Interface Sensor

Standard	RS485 2 wire, half-duplex
Transmission type	Protocol-transparent, 8 data bits, 1 stop bit, no parity
Tri-State	2 bit after stop bit edge
Transmission rate	19200 baud
Transfer size	0 ... 1200 m, twisted pair, screened
Function display	LED green on data reception, on for approx. 0.5 s
Connection	COMBICON plug-in connector 0.2 – 2.5 mm ² (AWG 24 – 12)

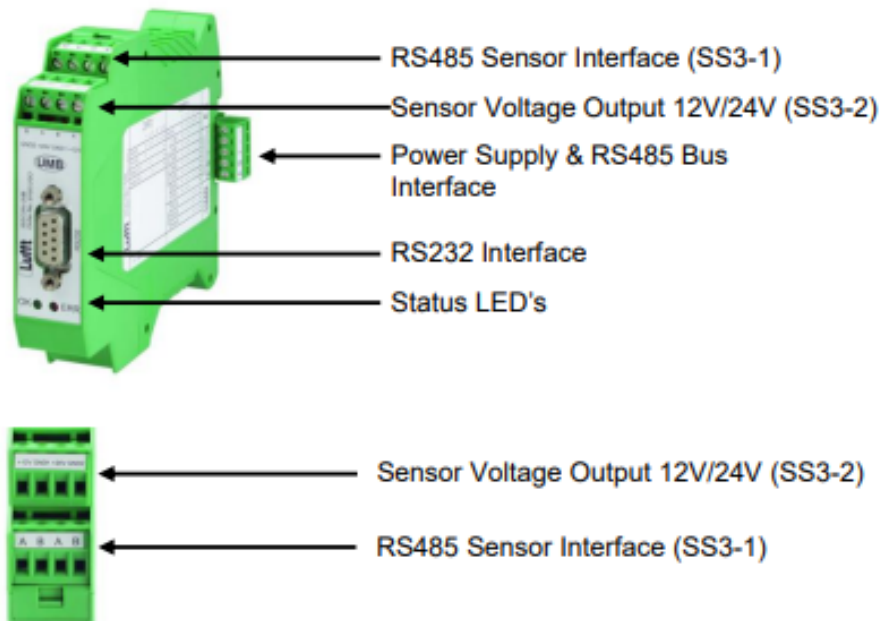

Figure 14. ISOCON-UMB pinout wiring

RS485 interface internal bus

Standard	RS485 2 wire, half-duplex
Transmission type	Protocol-transparent, 8 data bits, 1 stop bit, no parity
Tri-State	2 bit after stop bit edge
Transmission rate	19200 baud
Connection	Phoenix bus connector, gold, 5 pole, maximum 8A

Sensor power supply

12 V output	max. 150 mA, electrically isolated
24 V output	max. 2 A (observe the maximum current of the internal bus)

Storage conditions

Permissible ambient temp.	-40 ... 70°C
Permissible rel. humidity	0 ... 95% RH (non-condensing)

Operating conditions

Permissible operating temp.	-30 ... 60°C
Permissible rel. humidity	0 ... 95% RH (non-condensing)

Housing

Material	PA-V0, green
Width x Height x Depth	22.5 x 99 x 118.6 mm
Protection class	IP20
Weight	approx. 120 g
Connections	COMBICON plug-in connectors 0.2 – 2.5 mm ² (AWG 24 – 12)

2.9 SURGE PROTECTION UMB

Surge protection (for Lufft UMB - weather sensors) protects against voltage spikes. The surge protection serves to protect the LUFFT UMB sensors and is installed between the ISOCON-UMB and the UMB sensor. It is required for each UMB sensor.



Figure 15. UMB Surge protector

Material	Polyamide, yellow
Dimensions	22.5 x 99 x 92 mm
Protection type	IP20
Connections	COMBICON connector 0.2 - 2.5 mm ² (AWG 24 - 12)
Operating temperature	-30 ... +70 °C
Admissible height above absolute altitude	N/A
Storage conditions	
Admissible storage temperature	-40 ... +70 °C
Operating rel. humidity	0 ... 100 % RH
Communication backup path	
Max. operating current	100 mA
Max. operating voltage	33 V
Rated leakage current	20 kA (8/20 μs)
Supply voltage backup path	
Max. operating current	6 A
Max. operating voltage	25 V
Rated leakage current	20 kA (8/20 μs)

Figure 16. UMB Surge protector specification

2.10 Instrumentation Towers

Instrumentation towers are stable structures on which components of RWIS are mounted. The towers varies from 3 to 10 meters. Towers allow greater measurement heights than typical instrument tripods.

A typical 10-meter tower includes three 3 m sections, one extendable mast, and two cable tie kits. The extendable mast has a 1.5 m length and a 3.175 cm outer diameter.

Top 3 m Section - The top section is constructed from 2.5 cm OD aluminum tubing. Its width is 25.7 cm on a side.

Center 3 m Section - The center section is constructed from 2.5 cm OD aluminum tubing. Its width is 33.3 cm on a side.

Bottom 3 m Section - The bottom section is constructed from 3.175 cm OD aluminum tubing. Its width is 43.2 cm on a side.

This tower requires a mounting base and grounding kit.

	Tower-1	Tower-2
Measurement height	6 m (20 ft)	10 m (30 ft)
Shipping weight	23 kg (50 lb)	29 kg (65 lb)
Material	Hardened drawn 6063-T832 Aluminum	
Top tower section 3 m tube OD (outside diameter)	2.5 cm (1 in)	2.5 cm (1 in)
Top tower section width (center of tubing to center of tubing)	33.3 cm (13.1 in)	25.7 cm (10.1 in)
Center tower section tube OD	n/a	2.5 cm (1 in)
Center tower section width (center of tubing to center of tubing)	n/a	33.3 cm (13.1 in)
Bottom tower section tube OD	3.175 cm (1.25 in)	2.175 cm (1.25 in)
Bottom tower section width (center of tubing to center of tubing)	43.2 cm (17 in)	43.2 cm (17 in)
Adjustable mast OD	3.175 cm (1.25 in)	
Adjustable mast length	1.5 m (5.0 ft)	
Cross support pipe OD	0.953 cm (0.375 in)	
Guyed tower area requirements	~3.5 m (11.5 ft) radius	~5 m (17 ft) radius
Required concrete pad dimensions for concrete mounting base	91 L x 91 W x 122 D cm (36 x 36 x 48 in)	
Maximum wind load recommendations	177 km/h (110 mph) for gusts (UTBASE base, unguyed) 177 km/h (110 mph) for gusts (RBM18 base with/UTGUY)	
GUY material	Mixture of galvanized steel and 304 stainless steels	

2.11 2J Antennas Saltshaker Antenna - LL100 Cables



Figure 17. Saltshaker antenna

Key features include CELLULAR / LTE - 698-960 MHz - 1710-2170 MHz - 2500-2700 MHz, screw mount, customizable cable, and connector.

Dimensions: 60 x 69 mm

Certificates IP67, IP69, IK09

1. Antenna and electrical specifications

Cable 1		CELLULAR / LTE Antenna		
Parameters		2G,3G and 4G		
Standards		2G,3G and 4G		
Band (MHz)	700/850/900	1700/1800/1900/2100	2600	
Frequency (MHz)	698-960	1710-2170	2500-2700	
Return Loss (dB)	~-6.9	~-15.3	~-16.7	
VSWR	~-2.9:1	~-1.4:1	~-1.4:1	
Efficiency (%)	~-37.8	~-53.3	~-54.9	
Peak Gain (dBi)	~-0.8	~-3.6	~-4.1	
Average Gain (dB)	~-4.3	~-2.7	~-2.6	
Impedance (Ohm)		50		
Polarisation		Linear		
Radiation Pattern		Omni-Directional		
Max. Input Power (W)		25		
Connector Type		SMA-Male Standard (Other Connectors Available)		
Cable Length		300 cm Standard (Any Cable Length Available)		
Cable Type		LL100 Standard (Other Cables Available)		

Cable 2		CELLULAR / LTE Antenna		
Parameters		2G,3G and 4G		
Standards		2G,3G and 4G		
Band (MHz)	700/850/900	1700/1800/1900/2100	2600	
Frequency (MHz)	698-960	1710-2170	2500-2700	
Return Loss (dB)	~-6.8	~-14.3	~-9.3	
VSWR	~-2.8:1	~-1.5:1	~-2.1:1	
Efficiency (%)	~-38.7	~-52.3	~-42.1	
Peak Gain (dBi)	~-0.6	~-2.9	~-3.0	
Average Gain (dB)	~-4.2	~-2.8	~-3.8	
Impedance (Ohm)		50		
Polarisation		Linear		
Radiation Pattern		Omni-Directional		
Max. Input Power (W)		25		
Connector Type		SMA-Male Standard (Other Connectors Available)		
Cable Length		300 cm Standard (Any Cable Length Available)		
Cable Type		LL100 Standard (Other Cables Available)		

Figure 18. Saltshaker antenna specifications

2. Mechanical and environmental specifications

Specifications	2J7724Ba
Mounting Type	Screw Mount
Dimensions (mm)	Ø 60 x 69
Max. Tighten Torque (Nm)	6 Nm
Radome Type	PC/ABS UV Stable
Radome Color	Black
Antenna Base	Zamak
Gasket	TPE
Operating Temperature (C)	-40 to +85
Storage Temperature (C)	-40 to +85
Substance Compliance	RoHS
Certificates	IP67, IP69, IK09

Figure 19. Saltshaker antenna specifications cont.

2.12 Enclosures & Back Panel

An enclosure is a cabinet for electrical or electronic equipment to mount switches, dataloggers, circuit breakers, surge protection devices, connection terminals, batteries, displays, and other accessories. Regulations may dictate the features and performance of enclosures for electrical equipment. Electronic packaging may place many demands on an enclosure for heat dissipation, radio frequency interference and electrostatic discharge protection. Each enclosure provided for RWIS is a modified 24x20x10 Aluminum Enclosure, Nema 4X, non-painted with holes for cable glands. Glands are included; In addition, an aluminum back panel along with DIN rail and components are mounted inner the enclosure.

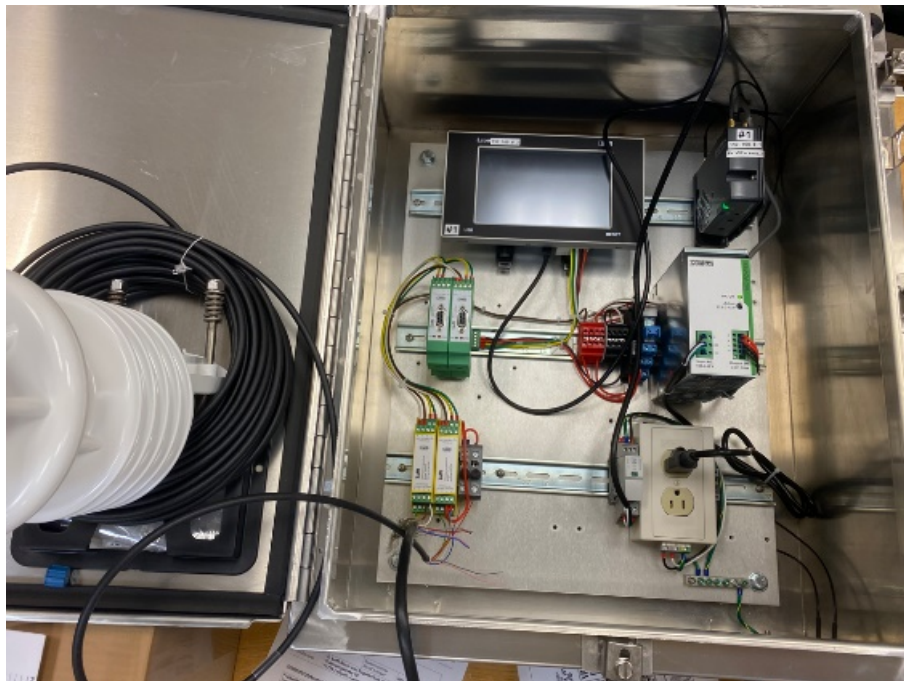

Figure 20. Inside of enclosure



Figure 21. Glands on enclosure

2.13 Station Wiring

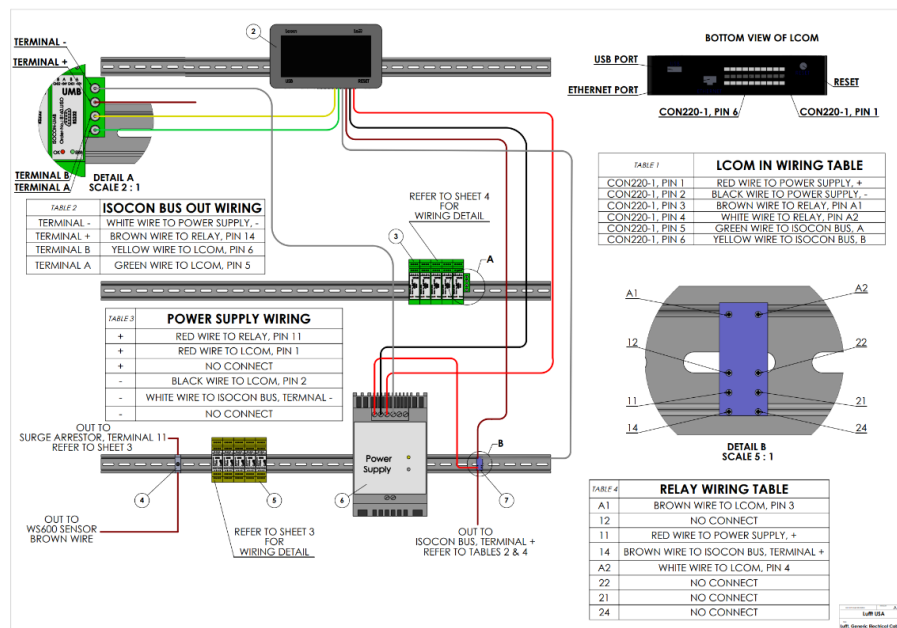

Figure 22. LCOM/ISOCON/Power supply wiring



! DANGER

Electrocution hazard. Always remove power to the instrument before making electrical connections.



! DANGER

Explosion hazard. Do not connect or disconnect electrical components or circuits to the equipment unless power has been removed or the area is known to be non-hazardous.

2.14 Power Distribution

Power distribution, surge protection, and grounding inside the Enclosures are all critical features of the integration systems and include all of the electrical, signal, and human safety considerations. The main incoming AC power flows through the provided AC/DC power supply, then is distributed to various equipment in the panels through terminals, power distribution blocks, fuses, and Surge protection devices.

2.14.1 Power Supply L8366.USV2 TRIO-PS/1AC/24DC/10

TRIO POWER power supplies are used in RWIS stations. TRIO POWER is particularly suited to standard machine production, thanks to 1- and 3-phase versions up to 960 W. The wide-range input and the international approval package enable worldwide use. The robust metal housing, high electric strength, and the wide temperature range ensure a high level of power supply reliability.

Advantages to TRIO POWER power supplies include:

- Use the third negative terminal block as a grounding terminal block and minimize installation costs
- Rugged design with metal housing and wide temperature ranges from -25 to +70°C
- Maximum operational reliability thanks to high MTBF (mean time between failures) of more than 500,000 hours and high dielectric strength of up to 300 V AC
- Compensation of voltage drops by means of output voltage that can be adjusted on the front

2.14.2 Cables

Cables of 2 types are used, one for power and another for signal. Cables consist of three major components: conductors, insulation, protective jacket. The makeup of individual cables varies according to application. The construction and material are determined by three main factors:

- Working voltage, determining the thickness of the insulation
- Current-carrying capacity, determining the cross-sectional size of the conductor(s)
- Environmental conditions such as temperature, water, chemical or sunlight exposure, and mechanical impact, determining the form and composition of the outer cable jacket.

A power cable is an electrical cable, an assembly of one or more electrical conductors, usually held together with an overall sheath. The assembly is used for transmission of electrical power. Power cables may be installed as permanent wiring within buildings, buried in the ground, run overhead, or exposed. Power cables that are bundled inside thermoplastic sheathing and that are intended to be run inside a building are known as NM-B (nonmetallic sheathed building cable). Power cables use stranded copper or aluminum conductors, although small power cables may use solid conductors in sizes of up to 1/0. (For a detailed discussion on copper cables, see: Copper wire and cable). The cable may include uninsulated conductors used for the circuit neutral or for ground (earth) connection. Signal cable is used in data transmission applications that demand superior signal protection. These applications require some of the smallest, most flexible, and highly screened cables on the market. Signal cables are used in a multitude of industries and can be found in everything from computers, medical equipment, and appliances.

2.14.3 Terminals

A terminal block is a modular, insulated block that secures two or more wires together. Factories use terminal blocks to secure and/or terminate wires. In their most basic form, terminal blocks consist of several individual terminals which are arranged in a long strip.

Fuse modular terminal block - Fuse terminal blocks are made up of one terminal block bottom section with a fuse insertion carrier. The fuses vary from pivoting fuse levers and pluggable fuse holders to screwable closures and flat plug-in fuses.

Feed-through terminal block - A feed-through terminal block is suitable for joining and/or connecting one or more conductors. They could have one or more connection levels that are on the same potential or insulated against one another.

Shortlinks - Removable shorting links are used to interconnect two adjacent terminal blocks temporarily and make switchable cross connection. The links are fitted onto the terminal blocks with long studs and screws. As the links rest above the top surface of the terminal blocks, they can be readily opened.

2.14.4 Fuse

Safety is the first concern when choosing electrical appliances or devices. When the power fluctuates or excess current flows, it causes damage resulting in an overload or short circuit. Fuses are one of the most common devices used in the early days to protect the circuit. A fuse contains a metal wire or strip that melts when an overflow of current occurs by stopping or interrupting the current.

2.14.5 The Surge Protection Device (SPD)

Surge Protection Devices (SPD) are used for electric power supply networks, and communication networks. The Surge Protection Device (SPD) is a component of the electrical installation protection system. Surge Protective Devices are designed to protect against transient surge conditions. Large single surge events, such as lightning, can reach hundreds of thousands of volts and can cause immediate or intermittent equipment failure. However, lightning and utility power anomalies only account for 20% of transient surges. The remaining 80% of surge activity is produced internally. Although these surges may be smaller in magnitude, they occur more frequently and with continuous exposure can degrade sensitive electronic equipment within the facility. This device is connected in parallel on the power supply circuit of the loads that it must protect. It can also be used at all levels of the power supply network. This is the most used and most efficient type of overvoltage protection. Surge protectors are designed to be installed inside of an enclosure and in very close proximity to the sensitive equipment that is being protected. The SPD is wired in series or parallel with the load.

RS485 COMMUNICATION OUTPUT

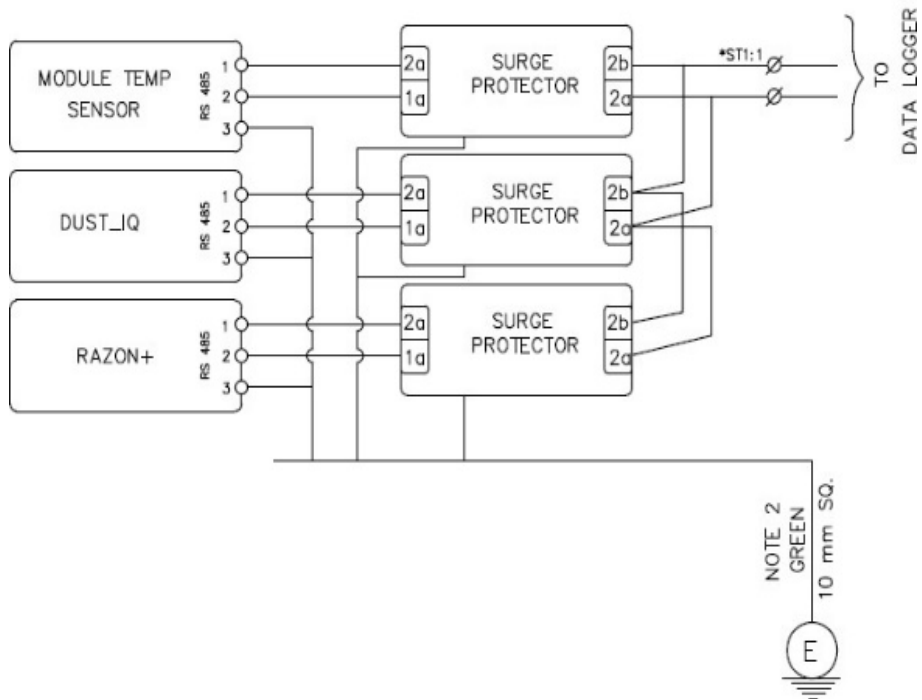

Figure 23. Examples of surge protectors in RWIS systems

ETHERNET CONNECTION DIAGRAM

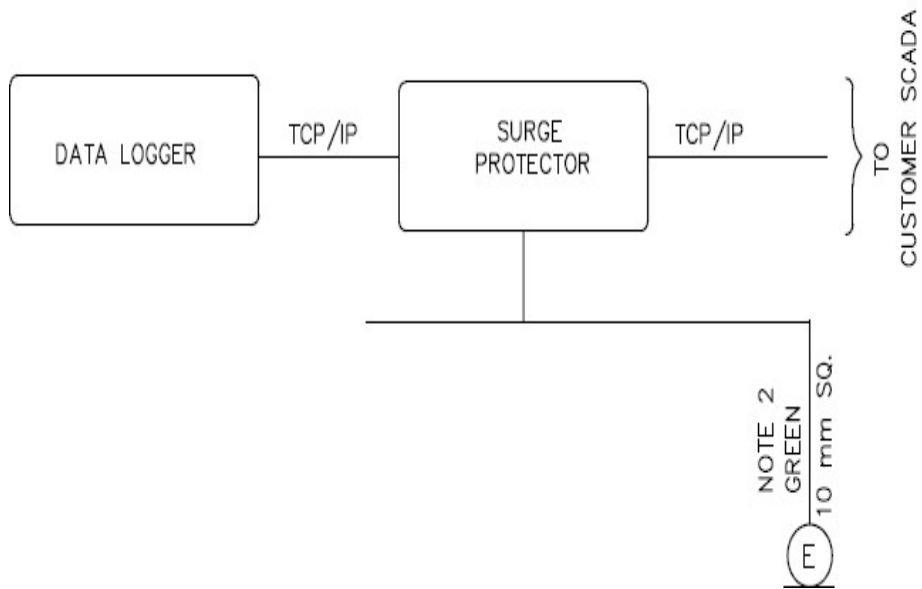

Figure 24. Examples of surge protectors in RWIS systems cont.

3 Installation

DANGER



Multiple hazards. Only qualified personnel must conduct the tasks described in this section of the document.



Live parts may be accessible inside the inner sensor housing if a fault occurs. Touching live parts may result in electric shock, which can cause serious or fatal injury.

Do not open the inner sensor housing door. Maintenance work may only be carried out by a trained service personnel. All maintenance work requires a technical qualification in electrical safety.

Switch off the external circuit breaker before carrying out any maintenance and repair work and secure against reconnection.



Touching live parts may result in electric shock, which will cause serious or fatal injury.

Switch off the external circuit breaker before starting the installation and secure against reconnection.

Multiple hazards are associated with installing, using, maintaining, and working on RWIS System. Failure to properly and completely assemble, install, operate, use, and maintain the entire installation, increases the risk of accident, serious injury, property damage, product failure and fatality. All reasonable precautions to be taken to avoid these hazards. Ensure conformance with statutory regulations, safety regulations.

General

- All required approvals and permits shall be obtained before starting the work at site.
- Only qualified personnel shall be utilized for installation, use, and maintenance of the RWIS systems
- All applicable instructions & procedures in various manuals shall be read carefully and understood thoroughly before beginning work.
- Personal Protection Equipment's like hardhat, Harnesses, gloves and eye protection shall be used as applicable.
- Use only OEM recommended parts, materials, and tools for installation & maintenance.

3.1 Mechanical Installation



WARNING

Multiple hazards. Only qualified personnel must conduct the tasks described in this section of the document.



WARNING

Personal injury hazard. Instruments or components are heavy.
Use assistance to install or move.



WARNING

Personal injury hazard.
Make sure that the wall mounting can hold 4 times the weight of the equipment.

3.1.1 Towers

3.1.1.1 Safety Guidelines for Erection of the Towers



Figure 25. Example of a tower with a cautionary sign

Working on tower involves hazards and dangers, being aware of the safety rules and regulations, can reduce the chances of such accidents and even save the lives of the workers. Ensure the following:

- Exercise extreme precaution while performing elevated work.
- Adapt required safety practices.
- Ensure use of appropriate equipment
- Take into account the weather conditions and forecast while performing work in wind, rain, snow, lightning seasons.

1. Training

Trained workers must be engaged only after confirmation & validation of certificates undergoing rigorous training and after they have done specific courses on the safety methods, how to operate safely and reduce the risk of a mishap. It is mandatory that subcontractors provide a training program for each employee who might be exposed to fall hazards. Not only is it important for everyone to take training courses, but it's even more crucial that everyone follows these safety recommendations. Safety procedures and certifications can mean life or death when it comes to cell tower work.

2. Safety Equipment

All tower construction and maintenance workers shall be supplied with the proper safety equipment & made sure that the equipment is always fully functional. Below is some of the equipment that shall be available when working on cell towers.

1. Helmet
2. Gloves
3. Safety Harness
4. Lifeline
5. Carabiners
6. Rope Grabs
7. Tool Belts
8. Lanyards

3. Team Coordination

Building, climbing, and repairing towers is more than a one-person job. Communicate with your team to have a plan and make sure everyone is aware of it.

4. Weather Conditions

Be aware of current and upcoming weather conditions. A little rain or snow can make the conditions more dangerous when working on cell towers. Take extra safety precautions as needed or delay work until conditions have improved.

5. Lower or Turn Off Power to RF Emitters

Being exposed to high radio frequency levels can be hazardous to a person's health. Make sure the power to the RF emitters is lowered or turned off, if possible, when working on towers.

3.1.1.2 Typical Tower Erection



Figure 26. RWIS tower in the field

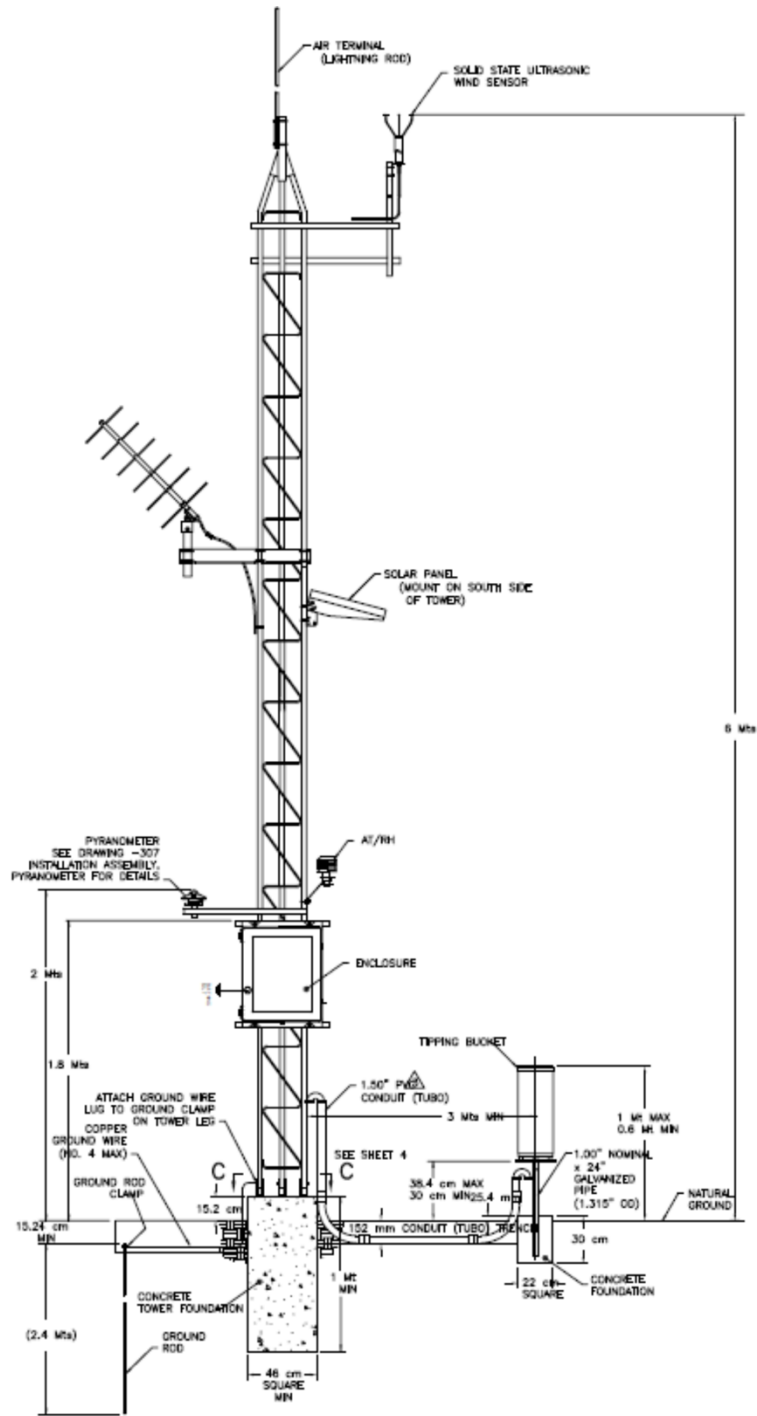

Figure 27. RWIS tower diagram

3.1.1.3 Base and Guy Anchor Layout

The tower attaches to a user-supplied concrete foundation as shown in FIGURE 7-1 (p. 9). The base brackets, anchor bolts, and nuts are included with the tower.

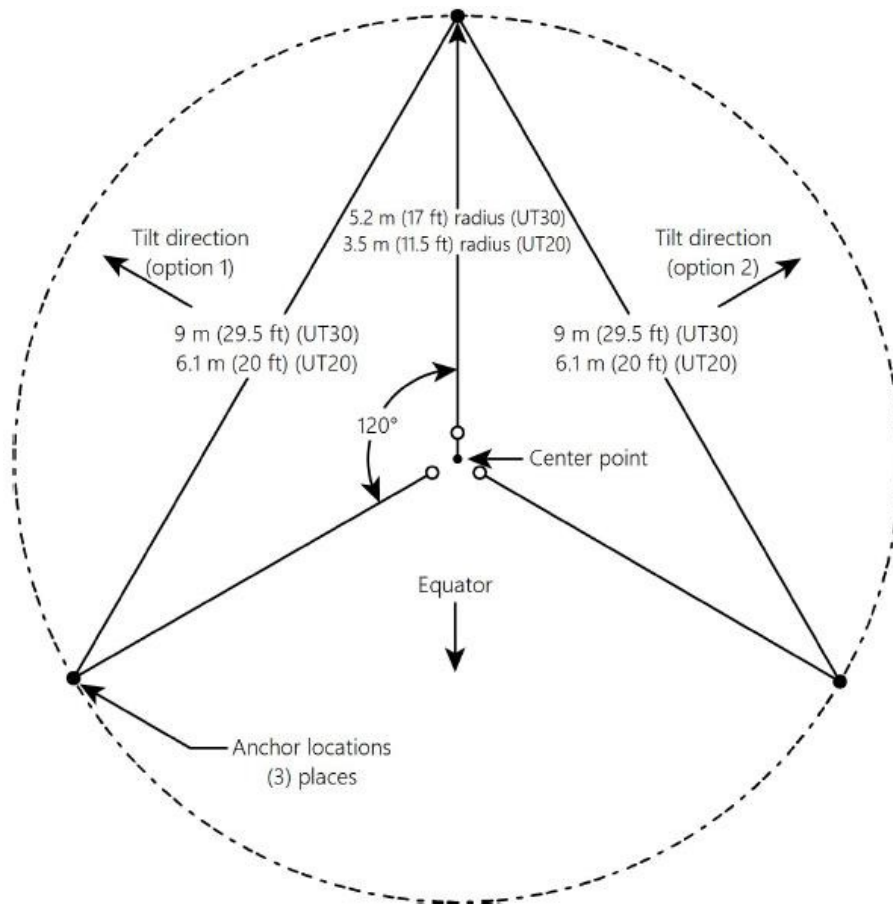

Figure 28. Tower base diagram

Drive a stake where the base of the tower will be located. Attach a line to the stake and scribe a circle with a 5.2 m (17 ft) radius for the 30 Foot Tower. The tower is typically positioned so two legs will be parallel to the equator as well as closest to the equator. The tower will then tilt away from the equator at an angle for servicing. Drive a stake on the scribed line opposite the direction the tower will hinge for the first guy anchor location. On unlevel ground, use a compass at the base stake to lay out the remaining two anchor locations 120 degrees from the first. Vary the distance between the tower and each anchor so that the angle between the tower and the guy wire will be approximately 30 degrees.

3.1.1.4 Tower base installation

The installation requires approximately 1 cubic meter of 3000 PSI concrete.

1. Dig a hole 0.9 m square and 1.2 m deep where the tower base will be located
2. Assemble the template and anchor bolts as shown. Each template piece is secured to the next with a template screw.
3. Once the three pieces are connected, thread a nut onto each anchor bolt, insert the bolt through the template, and thread a second nut onto the bolt. Tighten the lower nuts to secure the template against the upper nuts.
4. Wrap the visible threads next to the lower nut with masking tape to keep the threads clean as the concrete is placed.
5. If using the concrete form, assemble the form, then center the concrete form over the hole. Orient the concrete form so one side of the form faces the equator. Drive a wooden stake into the ground at each corner of the concrete form. Level the form and secure it in position.
6. Fill the hole with concrete. If using the concrete form, fill the form to the top of the wood frame. Screed the concrete, making sure it is level.
7. Immediately after screeding the concrete, determine the orientation of the BASE template. Orient the BASE template so one side of the template faces the equator. This arrangement is optimal for mounting a solar panel on two tower legs facing the equator. In instances where a crossarm needs to run perpendicular to the equator, such as precision pyranometer measurements, rotate the BASE template 90° so one side faces East or West.
8. Center the BASE template over the concrete and press the anchor bolts straight down into the concrete. Use a bouncing motion while working the anchor bolts into the concrete to help prevent any voids from forming around the anchor bolts. Continue pressing the anchor bolts into the concrete only until reaching the tape applied to the threads.
9. Remove the top nut from each anchor bolt and lift the BASE template off. Remove the remaining nuts and masking tape from the anchor bolts.
10. Apply anti-seize lubricant to the anchor bolt threads. Thread a clevis onto each anchor bolt until three threads are visible inside each clevis.
11. Place a connecting tube inside each clevis and attach it with two 3/8-16 x 2.75-inch bolts and locknuts. Each connecting tube is unique and is numbered 1 to 3
12. With the help of a second person, lower the bottom section of the tower into the three connecting tubes. Secure the tower section to the tubes.
13. Ensure the tower section is plumb. If the tower is not plumb, choose which leg needs to be adjusted and have a second person support the tower section while adjusting the clevis for the leg needing adjustment.
 - a. Remove both bolts from the clevis.
 - b. Turn the clevis clockwise to lower the leg and counterclockwise to raise the leg.
 - c. Reinsert the two bolts and finger-tighten the nuts.
 - d. Check the tower section again to see if it is plumb. If not, repeat steps a through c to refine the tower position as needed.
14. Fully tighten all the bolts on each leg.

3.1.1.4.1 Base installation



DANGER

Working at height hazards.



WARNING

Access for authorized climbers only.



WARNING

Wear safety harness.

Dig a hole 0.9 m square and 1.2 m deep where the tower base will be located. Attach the bottom section of the tower to the base using one bolt per leg, making sure that the hinge direction is common for all legs.



Figure 29. Examples of proper tower installation



Figure 30. Examples of proper tower installation cont.

3.1.1.4.2 Tower assembly

1. After installing the base and bottom tower section, remove the two bolts from leg 1. Remove the top bolt from the other two legs and loosen the remaining bolt in those legs so the bottom tower section is free to hinge. Tilt the tower section to the ground and assemble the remaining tower sections by using the hardware provided with the tower. Each section is secured to the section below it with three bolts. Route any cables from the upper sensors down the tower to where the enclosure will be mounted. Extend the mast to the height appropriate for the application and tighten the mast.

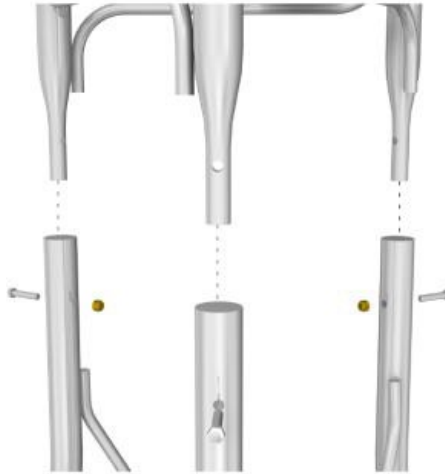

Figure 31. Each section of the tower is secured to the previous section using three bolts

2. Install the guy wires to the top of the tower. Cut the 36.5 m (120 ft) piece of guy wire into three pieces; lengths will vary with slope. Attach the guy wires to the tower by using two clamps for each guy wire.

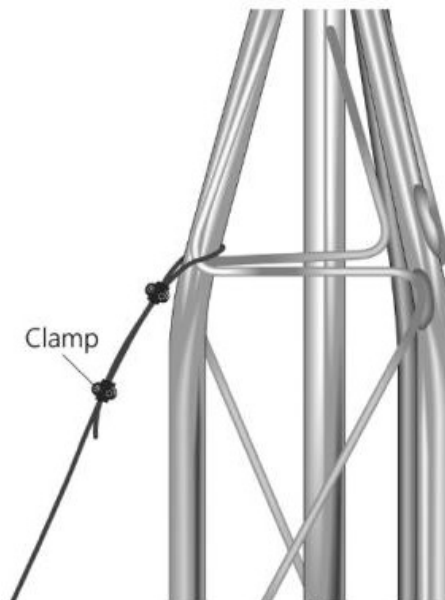

Figure 32. Guy wire is attached to the tower using clamps

3. The mounting brackets, sensors, and lightning rod that attach to the upper tower sections easily while the tower is lying on the ground.
4. 'Walk' the tower to its upright position and install the remaining bolts in the tower base.

5. Attach the guy wires to the anchors. Unscrew the jaw and eye bolts until 2.5 cm (1 in) of thread extends through the turnbuckle body. Attach the jaw end of the turnbuckles to the anchors. While holding the tower plumb, attach the guy wires to the eye end of the turnbuckles by using a thimble and two clamps for each guy wire. Tighten the turnbuckles until the guy wires are snug and the tower is plumb. Do not overtighten the turnbuckles.

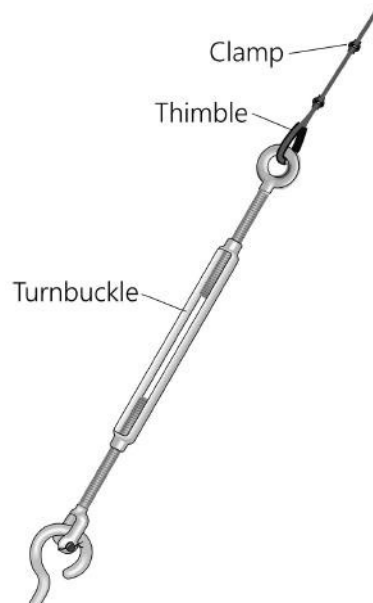

Figure 33. Guy wire is attached to the turnbuckle

Assembly

The method followed for the erection of towers shall ensure the points mentioned below-

- Straining of the members shall not be permitted for bringing them into the position. If, however, it is, necessary to match hole positions at joints to facilitate this tommy bars to be used.
- Before starting erection of an upper sections, the lower section shall be completely braced, and all bolts provided in accordance with approved drawings.
- All plan diagonals relevant to a section of tower shall be placed in position before assembly of upper section in taken up.

Checking as per Drawing

The tower erection shall be done in strict accordance with the approved drawings. If the stubs of super structures after the erection are found to differ from approved drawing or to be put off alignment, the tower shall be dismantled and re-erected.

Vertically

The towers must be truly vertical after erection and no straining will be permitted to bring them in alignment.

Tightening and Punching of Bolts & Nuts

All nuts shall be tightened properly using correct size spanners. Before tightening, it will be seen that filler washers and plates are placed in relevant gaps between members and bolts of proper size and length are used with flat washers. The tightening shall progressively be carried out form the top downwards, care being taken that all bolts at every level are tightened simultaneously. The threads of bolts projecting outside the nuts shall punched by chamfering the threads at three positions on the diameters to ensure that the nut are not loosened in course of time. During tightening, if a nut is found to be slipping or running over the bolt threads, the bolt together with the nut shall be replaced.

3.1.2 Ultrasonic Wind Speed Mounting

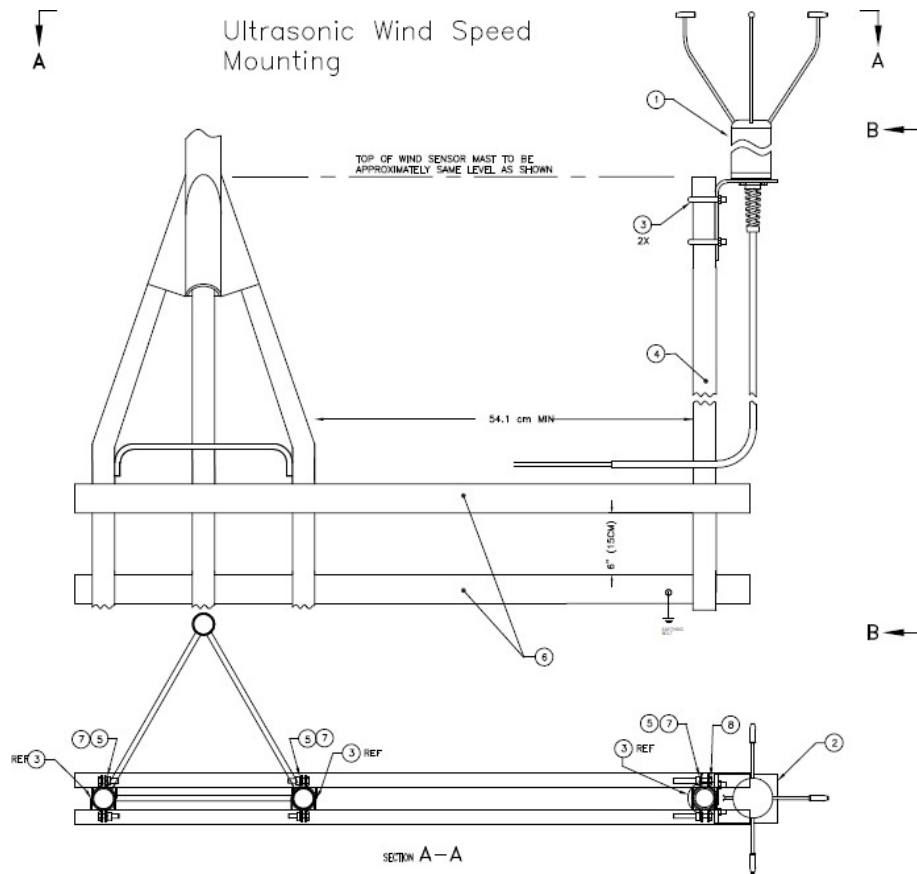

Figure 34. Ultrasonic wind speed mounting diagram

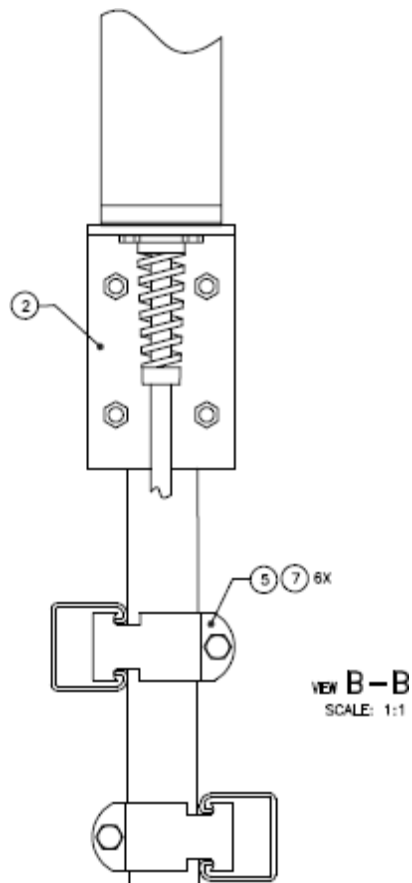

Figure 35. Ultrasonic wind speed mounting diagram cont.

3.1.3 Enclosures

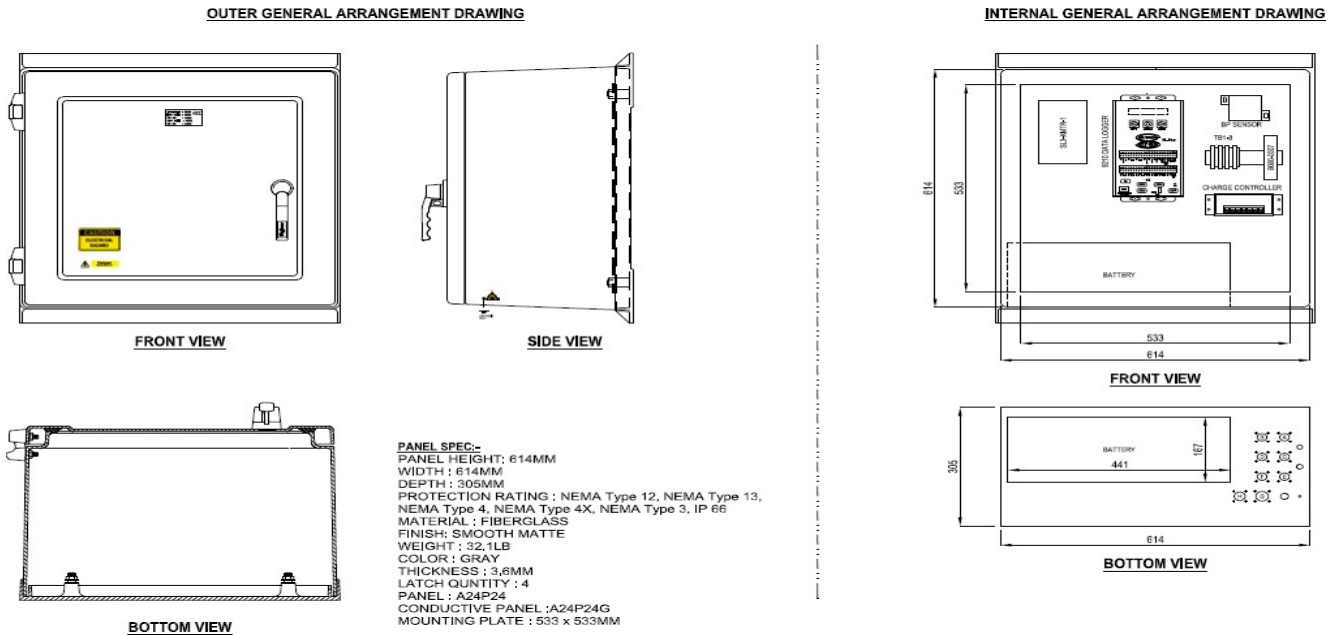

Figure 36. Enclosure diagram

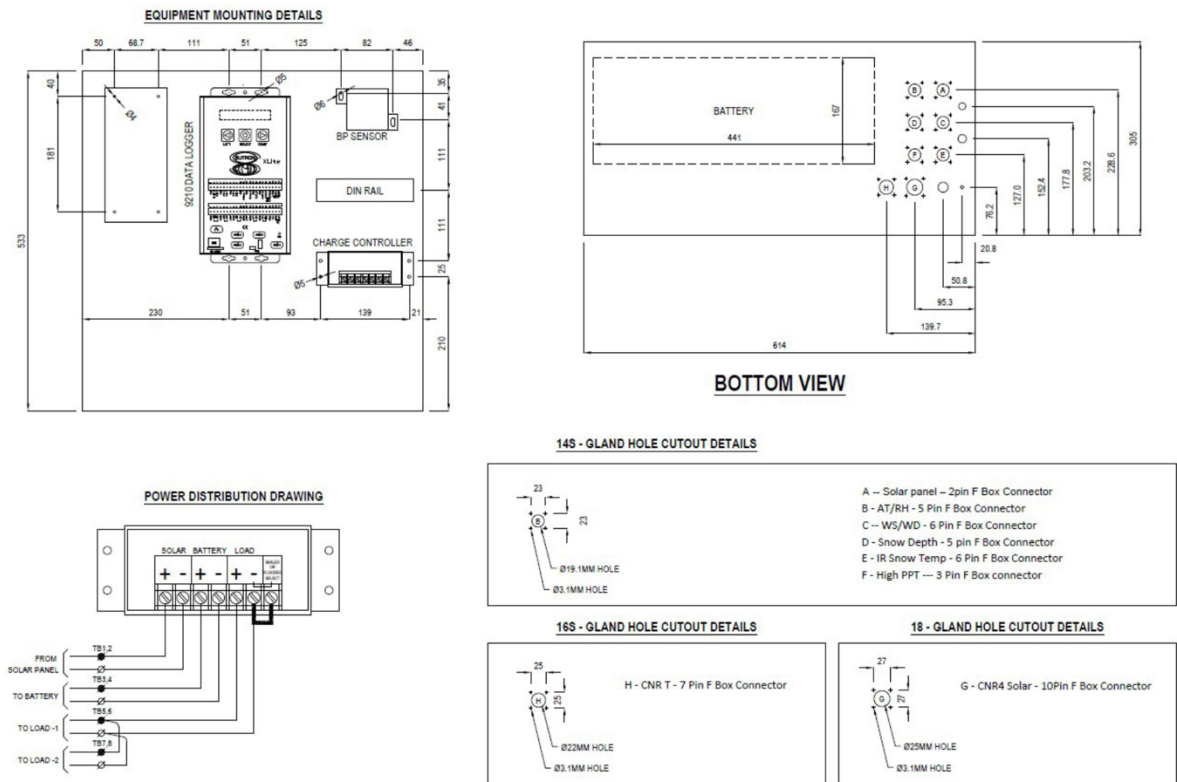

Figure 37. Enclosure diagram cont.

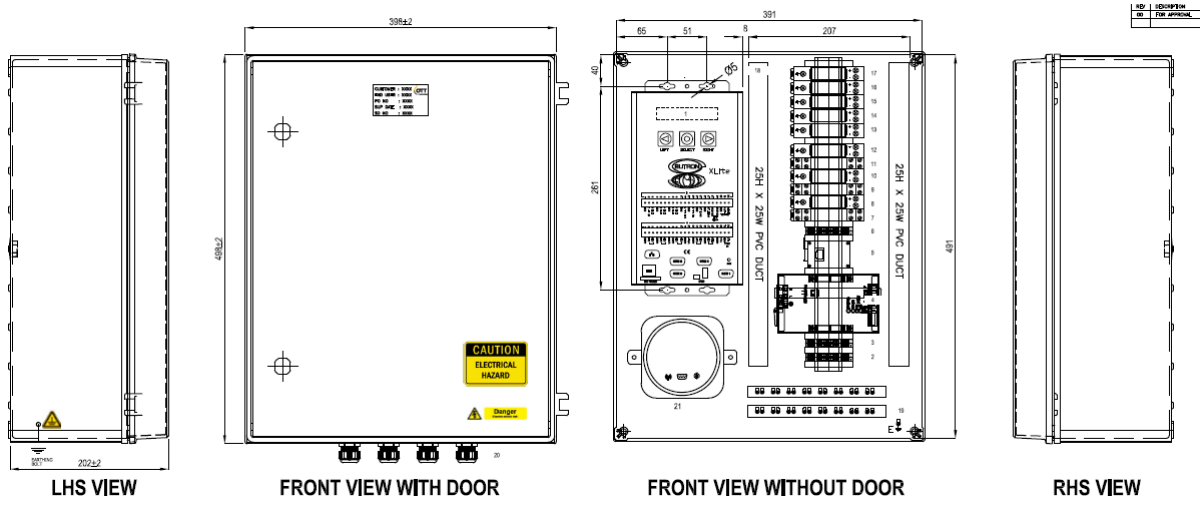

Figure 38. Enclosure diagram cont.

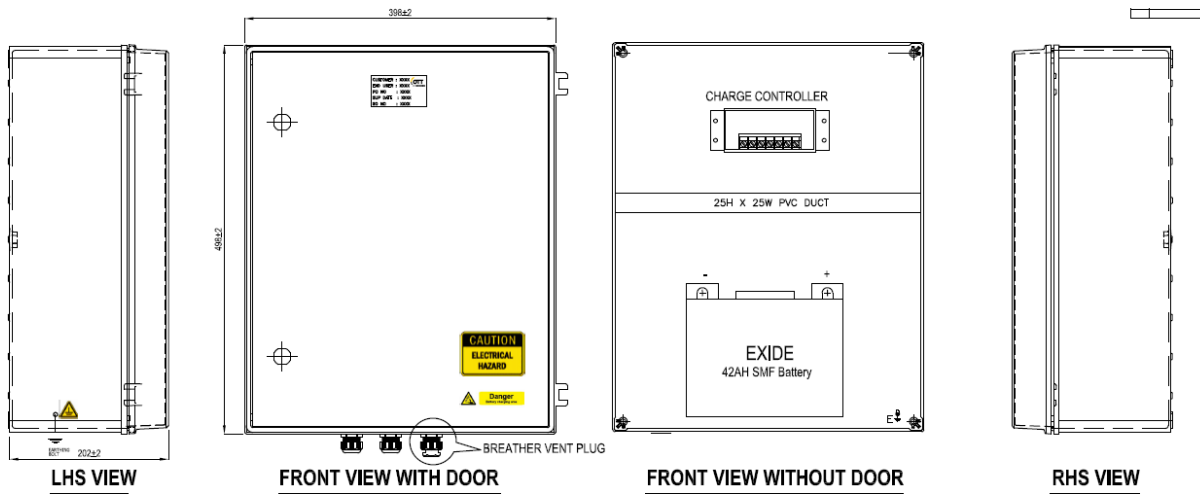

Figure 39. Enclosure diagram cont

3.1.4 Enclosure Mounting



! WARNING

Personal injury hazard. Instruments or components are heavy.
Use assistance to install or move.

The U Clamp is used to attach an enclosure to a tower which comes with a three-piece bracket mounted to the top of the enclosure and an identical three-piece bracket mounted to the bottom of the enclosure.

Attach the enclosure to the tower legs as follows:

- Remove the bolts and nuts connecting the bracket to the enclosure.
- Slide out the flange sections so that the distance between the centers of each flange is 43 cm (17 in)
- Reattach the bracket to the enclosure using the original bolts and nuts.
- Position the enclosure on a side of the tower facing away from the equator.
- Place the enclosure at the desired height, typically 1 m (3 ft) from the ground.
- Use the furnished 1.5-inch U-bolts to secure the enclosure to the tower legs.
- Route the 14 AWG wire from the tower ground clamp to the enclosure ground lug.
- Strip 2.5 cm (1 in) of insulation from each end of the wire and insert the end of the wire into the ground lugs and tighten.

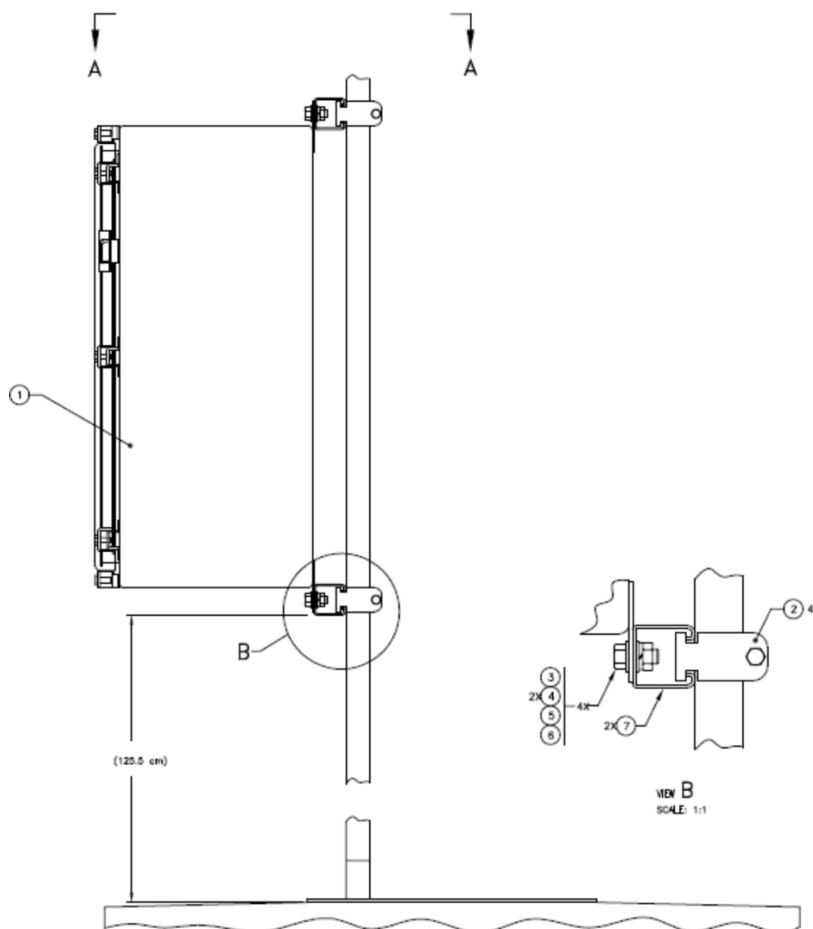

Figure 40. Diagram for mounting enclosures to pole



Figure 41. Mounted enclosure in the field

1. Structure

The solar panel mounts to the mast or leg of a tripod, to a tower leg, or any 1 5/8-inch schedule 40 pipe.

Select type of structure i.e Ground Mount, Rooftop Mount, Pole Mount or Tracker. A group of Modules mounted on single unit of structure and interconnected together is called PANEL.

This is made up of galvanized iron frames and angles. In this structure flexibility is provided to change the module- mounting angle seasonally. This structure is grouted by small civil work and modules are mounted subsequently. Also, this mounting structure should be earthed suitably at several places if voltage of the array is more than 50 Volts.

- Modules can be installed in both landscape and portrait modes - It is recommended to install the same size and the same type of module in one PV array.
- The PV modules shall be installed high enough to keep it away from potential shading, flying sands, snow and water

2. Earthing kit

Earthing kit is provided to earth the mounting structure. Provision of earthing shall be done as follows: The installation shall have proper earth terminals and shall be properly earthed.

3. Cables

We require different types of cables to connect module to module, modules to charge controller, charge controller to battery, or connect battery to load as required. The cable size used for interconnection of SPV module, Charge Controller and battery shall be minimum 2 X 2.5 sq. mm Cu. Cable.

3.2 Electrical Installation

Safety is a primary goal within the electrical industry, In an electrical circuit, there is what is known as a hot wire, which supplies the power, and a neutral wire, which carries that current back.



DANGER

Electrocution hazard.

Always remove power to the instrument before making electrical connections.



DANGER

Explosion hazard. Do not connect or disconnect electrical components or circuits to the equipment unless power has been removed or the area is known to be non-hazardous.

Keep Clear of Utility Lines: Danger of sustaining serious bodily injury any of the installations come in contact with overhead or underground utility lines. Comply with all local electrical codes. Electrical equipment and related grounding devices should be installed by competent personnel.

3.2.1 Electrostatic discharge (ESD) considerations



NOTICE

Potential Instrument Damage. Delicate internal electronic components can be damaged by static electricity, resulting in degraded performance or eventual failure.

Refer to the steps in this procedure to prevent ESD damage to the instrument:

- Touch an earth-grounded metal surface such as the chassis of an instrument, a metal conduit or pipe to discharge static electricity from the body.
- Avoid excessive movement.
- Wear a wrist strap connected by a wire to earth ground.
- Work in a static-safe area with anti-static floor pads and work bench pads.

3.2.2 Grounding



! DANGER

Electrocution hazard.

Always remove power to the instrument before making electrical connections.

Proper Grounding enables the overcurrent parts to positively and speedily open and de-energize the circuitry to remove the power source. Therefore, it can stay operating and energized, likely making the electrical enclosure to have a non-zero voltage.

People working around or within this enclosure box might get an electrical shock from the floating voltage. An additional 'grounding wire' can be attached to outlets and other electrical devices and securely connected to the ground. This ground wire is an additional path for electrical current to return safely to the ground without danger to anyone in the event of a short circuit. If a short circuit did occur, the current would flow through the ground wire, causing a blown fuse or tripped circuit breaker – an outcome much preferable than the fatal shock that could result if the current was not grounded.

Having electrical system grounded means it will be easy for power to be directed straight to wherever needed, allowing electrical currents to travel throughout the electrical system safely and efficiently.

A grounded electrical system also makes it easier for the right amount of power to be distributed to all the right places, which can play a huge role in helping to ensure circuits aren't overloaded and blown. The earth provides a common reference point for the many voltage sources in an electrical system.

One of the reasons why grounding helps to keep you safe is because the earth is such a great conductor, and because excess electricity will always take the path of least resistance.

By grounding your electrical system, you are giving it somewhere to go other than into you - Prevents damage, injury and death.

Without a properly grounded electrical system, a risk is being carried on appliances connected to the system being burnt beyond repair. In the worst-case scenario, an overload of power can even cause a fire to start, risking not just extensive property and data loss but physical injury as well.

3.2.3 Earth Grounding of Electrical Enclosure

From a safety perspective, an electrical enclosure should be positively and correctly grounded to rid any electrical faults. This is the first step that should be taken in setting up an enclosure.

Ungrounded or improperly grounded electrical enclosure will not get rid of a fault as speedily in case it does. Resistance of the ground path from the electrical enclosure box back to source ground should be very low. This ensures that when an energized conductor touches the enclosure, the consequential fault current gets low- impedance path to securely conduct to ground. Proper electrical enclosure grounding is a vital facet for providing safety, performance, and uptime. The electrical enclosure will perform as usual with incorrect grounding, though will result in a danger if a fault happens. Enclosures typically feature an input power feed having a grounding conductor that is ultimately bonded to the electrical enclosure.

The electrical system components are linked to the earth ground by a grounding bar within the electrical enclosure. In case an electrical fault happens, like ground fault or short circuit, the ground acts as safety feature guard against associated hazards.

It is in effect to revert the power to its source, where the surge in current sets off overcurrent gadgets like circuit breakers and SPD's. These breakers then launch and stop the current flow.

Some of the usual termination ways for ground wires include:

- Grounding Lug: The fitting features a compression section that receives the incoming cable. There is a hole enabling you to bolt it to an appropriate back panel or enclosure stud.
- Grounding Terminal / Grounding Stud: A compression terminal block, commonly colored green/yellow or green, that grounds to DIN rail if installed or back panel / Mounting Plate.

Enclosures are typically metal and feature an interior metal back panel/mounting plate used for mounting components. Even non-metallic electrical enclosures consist of a metal back panel. A UL-listed electrical enclosure will come accompanied with the relevant documents, which must be followed during installation. It will include the hardware that is used for grounding all the metallic components of the enclosure cabinet. Connect the incoming ground onto a back panel-installed grounding terminal, bar, or lug. This connector links the ground conductor to enclosure back panel. Back panels are mounted using machine screws or nuts and star washers to make sure they are attached to the metal electrical enclosure. Metal doors, regardless of removeable-hinge or continuous-hinge type, will have independent bonding jumper from back panel or enclosure to the door. The doors feature studs for this role. Electrical enclosure grounding connections done at painted exteriors have the paint scrapped to bare metal.



! DANGER

Electric shock risk.



! CAUTION

Electrical hazard.

VRLA batteries:

- Remove all personal metal objects (watches, rings, etc.)
- Use insulated tools.
- Wear full eye protection and rubber gloves.
- Observe circuit polarities.
- Do not make or break live circuits.
- Prior to handling batteries on a metal rack, assure the battery is not accidentally grounded by observing the ground fault detector indicator. In its absence, measure the voltage between the battery and the rack. It should be zero. If not, determine the cause and correct prior to proceeding.
- Do not lay metal tools and hardware on top of the batteries.
- As appropriate, use an insulating blanket to cover exposed portions of the battery system when performing extended maintenance that could result in personal or equipment contact with the energized conductors.

VRLA Battery Chemical Hazards



⚠ DANGER

Batteries contain acid.



⚠ WARNING

Avoid contact with skin and eyes.

- Any gelled or liquid emissions from a VRLA battery is electrolyte which contains dilute sulfuric acid that is harmful to the skin and eyes.
- The electrolyte is also electrically conductive and corrosive.
- If the electrolyte contacts the skin, wash the area immediately and thoroughly with water.
- If electrolyte enters the eyes, wash your eyes thoroughly for a 10-minute period with clear water or a special neutralizing eye wash solution and seek immediate medical attention.

Fire, Explosion and Heat Hazards



⚠ DANGER



⚠ DANGER

- Lead acid batteries can contain an explosive mixture of hydrogen gas which can vent under overcharging conditions.
- Do not smoke or introduce sparks in the vicinity of the battery.
- Prior to handling the battery, touch a grounded metal object, such as the rack, to dissipate any static charge that may have developed on your body.
- Do not charge batteries in a sealed container. The individual batteries should have 5 to 10 millimeters of space between them to allow for proper cooling. If contained, assure the container, cabinet or room has adequate ventilation to prevent an accumulation of potentially vented gas

A VRLA battery or Valve Regulated Lead Acid Battery is a sealed battery or maintenance-free battery. This is one type of Lead-acid rechargeable battery. Also, we can mount the battery in any orientation. The reduced ventilation requirement is an added advantage of VRLA. The VRLA battery occupies less mounting space and moderate room ventilation.

The electrolyte is captive, preventing it from spilling even when its case is punctured. VRLA batteries are 'maintenance free' and it does not require additional electrolyte or water.

When the lead-acid battery charging is near completion, hydrogen (H^2) gas liberates at the negative plate. Similarly, at the end of battery charging oxygen (O^2) gas liberates at the positive plate. Hydrogen gas is released before mixing with water inside the battery. It happens because the reverse process of battery discharging to charging is not perfect.

To prevent the build-up of the explosive hydrogen gas, a battery has a vent to release the pressure. The electrolyte may spill out from the vents with tilting of the battery. This is a hazard during the shipping of the batteries and makes the battery unsuitable for many applications. Also, proper ventilation is required in the room.

The valve-regulated lead-acid batteries hinder the movement of the electrolyte inside the battery container and it traps the hydrogen gas near the plates. Thus, this process makes readily available hydrogen gas for re-combination during battery charging.

This type of construction greatly reduces water loss during the charging and discharging cycle. Thus, this technology makes the battery sealed and maintenance-free (no need to add water). This is the reason why we can use VRLA batteries in any position or orientation. There is no possibility of electrolyte spillage in VRLA. also, no water needs to add to the electrolyte in VRLA sealed maintenance-free batteries.

Protection in Enclosure

Safety Breather Vents are used in the enclosures to allow the air inside of an enclosure to breathe with the surrounding atmosphere and to allow any moisture that enters the enclosure to drain, or vent while maintaining Increased Safety method and overall integrity of the installation. These drains are certified for Increased Safety use.

When charging rechargeable batteries, certain amounts of hydrogen and oxygen gas (hydroxide gas) can be released from the chemical reactions inside the batteries. This released gas is extremely flammable, hence Safety Breather Vents are provided in the enclosure to allow the hydroxide gas inside of an enclosure to dissipate outside the enclosure in the surrounding atmosphere thus preventing the build-up of the explosive hydroxide gas in the enclosure.



Figure 42. Example of glands on the enclosure

4 Maintenance

The purpose of this section in the manual is to establish guidelines for maintenance of the Installed RWIS over the course of each year. These tasks are very important to ensure not only the life of the equipment but, also to ensure the accuracy and validity of the data.

Site visits should be made frequently to weather stations for general upkeep and site maintenance. Each visit should be documented (according to the Weather Station Field Checklist). Typically, maintenance to specific parts, sensors, and replaceable materials is on a six-to-twelve-month basis (according to the Maintenance Schedule). Careful planning of maintenance activities and general station maintenance will help keep visits to a minimum. This section describes the tasks that should be performed during each maintenance routine at scheduled regular interval. It is very important that prior to performing any maintenance work on the sensors or datalogger, the data needs to be backed up to prevent any data loss of data. After completion of each maintenance routine, a detailed maintenance logs documenting all the actions taken during the visit.

4.1 Installation Site

The area inside the fencing should be kept in good order. High grass and weeds should be removed from time to time as it will pose a problem for access to the station and may impede the measurements performed by the sensors.

4.2 Structure

It is important to carry out maintenance at regular intervals as detailed in this section to preserve the integrity of the structure. Regular inspection of bolts, guy wires, clips and ground anchors for any rust or corrosion.

4.3 Electrical

Check all the wiring and electrical connections regularly for any signs of wear or damage, including all earth connections. Where mains power is involved, it is essential that you check for effective earthing of components before any maintenance work or testing is carried out.

4.4 Equipment

4.4.1 Enclosure

Ensure Sealing the cable gland used for cable entry. Desiccant packets inside the enclosure should be replaced with fresh packets as per the recommendation to control humidity inside the Enclosure.

Below are the recommended battery's actions to check at regular intervals:

- the vent openings of the battery housing to ensure unhindered air circulation. Remove any contamination.
- the rechargeable battery for damage, deformation of the housing and any leaking battery acid.
- the connection terminals of the rechargeable battery for dirt and tightly connected leads.
- the battery voltage (fully charged, not loaded $U_{min} \geq 12 V$).
- the remaining capacity of the rechargeable battery with an appropriate battery tester. Replace the rechargeable battery after 10 years of operation at the latest; earlier if the remaining capacity is low or in extreme climatic conditions.

4.4.2 LCOM Communicator Datalogger

The LCOM Datalogger requires very little maintenance. The datalogger utilizes non-volatile memory, which means that the memory of the datalogger is kept powered using an internal battery.

4.4.3 NIRS31 non-invasive road weather Sensor

The following are required for maintenance:

- Hexagon socket wrench, size 6
- Reflector unit (spare part)

Maintenance on the sensor must be performed in accordance with the indication 'Remaining Time to Next Service'; this is due approximately once every two years. The following work must be carried out:

- Replace the reflector unit
- Clean the transmitter and receiver plate
- Function test / renew Adaption

Note: Maintenance works must be performed by trained specialists only and in dry weather, as the housing must be opened. Otherwise, the equipment can be damaged due to the presence of moisture inside the unit.

Important note: When carrying out maintenance, the same conditions that are required for commissioning must be met and the instructions for commissioning must be observed, as a new adjustment of the sensor takes place automatically after maintenance.

Replacing the Reflector Unit

To replace the reflector unit it is necessary to open the device by loosening the two screws on the front.

Note: Hold the front of the sensor while loosening the screws to ensure that the front of the sensor does not fall downwards. Remove the reflector unit connection cable and the 3 retaining springs. Refer to the NIRS31 manual page 31 thru 33 for further maintenance details.

4.4.4 WS600-UMB Smart Weather Sensor

In principle the equipment is maintenance-free. However, it is recommended to carry out a functional test on an annual basis. When doing so, pay attention to the following points:

- Visual inspection of the equipment for soiling
- Check the sensors by carrying out a measurement request
- Check the operation of the fan (not on WS200-UMB)

In addition, an annual calibration check by the manufacturer is recommended for the humidity sensor (not on WS200-UMB). It is not possible to remove or replace the humidity sensor. The complete Smart Weather Sensor must be sent to the manufacturer for testing. Cleaning of the glass dome at regular intervals is suggested for devices with global radiation measurement. The length of the interval should be adapted to the local degree of pollution. Devices with precipitation measurement by rain gauge (WS401-UMB, WS601-UMB): The rain gauge funnel needs to be cleaned at regular intervals (see below). The length of the interval should be adapted to the local degree of pollution.



WARNING

Devices with precipitation radar must be disconnected from power during maintenance service.

Repair/Corrective Maintenance Please arrange for any faulty equipment to be checked and, if necessary, repaired by the manufacturer exclusively. Do not open the equipment and do not under any circumstances attempt to carry out your own repairs.

4.4.5 Weather Considerations

During winter months, special considerations should be observed, especially regarding ice accumulation on sensors. Wind measurements are most affected by this. The wind sensor housing can accumulate ice and snow causing an inaccurate and may report reduced speed measurements and incorrect direction measurements. For this reason, it is important to turn the wind sensor heater on under icy/snow conditions.



Contact Information

