



WS50PV

Compact All-in-One Weather Sensor

Measuring the most critical parameters for commercial and industrial PV monitoring



1.2 kg

FC IP 66

-40 °C to 60 °C
-40 °F to 140 °F

Delivery Contents

- ① WS50PV device
- ② Cable
- ③ Instruction sheet
- ④ Calibration Certificate

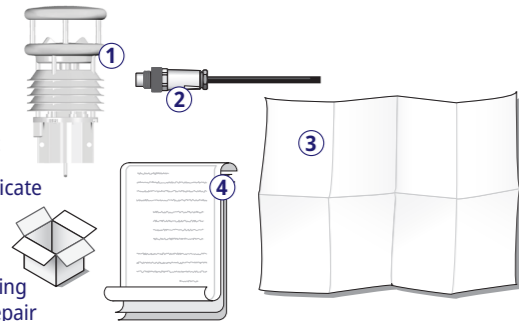

Keep original packaging for recalibration or repair

Available accessories [only one accessory can be added at a time]

- WT1 Ext. temp. sensor. Order no.: 8160.WT1
- WBT100 Rain gauge. Order no.: 8353.10

Safety instructions

Installation and commissioning must be carried out by suitably qualified specialist personnel only. Never take measurements on or touch live electrical parts. Pay attention to the technical data and storage and operating conditions.

Warranty

The warranty period is 12 months from the date of delivery. The warranty is forfeited if the designated use is violated.

Brand names

All brand names referred to are subject without limitation to the valid trademark and ownership rights of the respective owner.

Maintenance

Please arrange for any faulty equipment to be checked and, if necessary, repaired by the manufacturer exclusively. Do not open the equipment and do not under any circumstances attempt to carry out your own repairs.

Disposal

Please comply with the applicable regulations for the proper disposal of waste electrical and electronic equipment in your respective country.

In matters of warranty or repair please contact technical support at +1 (800) 949-3766 or NAtechsupport@otthydromet.com



FCC/ICES Suppliers Declaration of Conformity (SDoC)
EMC Emissions Compliance Information

PRODUCT MODEL : WS50PV

TEST FACILITY & REPORT NUMBER : Phoenix Testlab, Blomberg - Germany / F200299E2

US FCC VERIFICATION STATEMENT:
Per 47 CFR Section §15.107 (b) (3) and §15.109 (b) (3)

This device complies with FCC Part 15 Rules (Class B limits).
Operation is subject to the following two conditions:
(1) this device may not cause harmful interference, and
(2) this device must accept any interference received, including interference that may cause undesired operation.

US RESPONSIBLE PARTY : Ott Hydromet Corporation (importer)

- ADDRESS (USA) : 22400 Davis Drive, Sterling, VA 20164
- TELEPHONE (USA) : +1 (703) 406-2800
- WEBSITE : www.otthydromet.com

CANADA ICES VERIFICATION STATEMENT:
Per Section 8 ISSED STANDARD ICES-003 Issue 6

This device complies with / Cet appareil est conforme à la norme CAN ICES-003 (B) / NMB-003 (B)
Operation is subject to the following two conditions / Le fonctionnement est soumis aux deux conditions suivantes :

(1) this device may not cause interference, and
cet appareil ne doit pas causer d'interférences, et
(2) this device must accept any interference, including interference that may cause undesired operation of the device.
(2) cet appareil doit accepter toutes les interférences, y compris celles susceptibles de provoquer un fonctionnement indésirable de l'appareil.

CANADA RESPONSIBLE PARTY : Chris Bartheaux

- ADDRESS : 2571 Crystalview Drive, Victoria, BC V9B6M8
- TELEPHONE : +1 (703) 406-2800
- WEBSITE : www.otthydromet.com

WS Part #: 8373.PV

Rev 1.4

© 2021 | All rights reserved

www.otthydromet.com
48.7235-WS50PV-210217

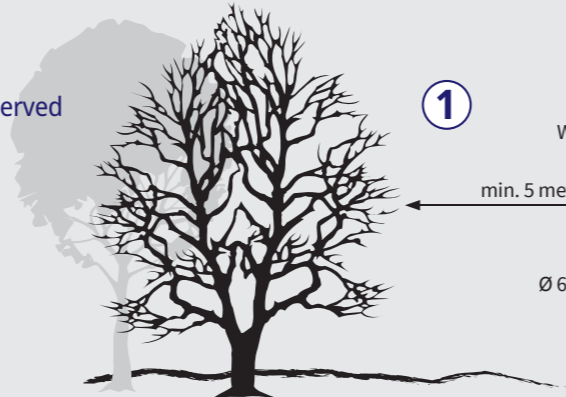

Imperial		Metric		Measurement value	Unit	Scaling
Actual	Statistical	Actual	Average			
10	40	110	140	Device status	digit	1
11	41	111	141	Air temperature	°F °C	10
12	42	112	142	Dew point temperature	°F °C	10
13	43	113	143	Relative humidity	%	10
14	44	114	144	Relative air pressure	hPa	10
15	45	115	145	Absolute air pressure	hPa	10
16	46	116	146	wind direction	°	10
17	47	117	147	Wind speed	mph m/s	10
18	48	118	148	Wind speed (min)	mph m/s	10
19	49	119	149	Wind speed (max)	mph m/s	10
23	53	123	153	External sensor temperature	°F °C	10
24	54	124	154	Total precipitation [high-word]	mil mm	100
25	55	125	155	Total precipitation [low-word]	mil mm	100
26	56	126	156	Precipitation diff.	mil mm	100
27	57	127	157	Precipitation intensity	mil/h mm/h	100
28	58	128	158	Precipitation type code	digit	1

Please note that all references to external temperature and precipitation need external accessories. Registers 23-28, 53-58, 123-128 and 153-158.



Pin Layout (Instrument)

Wire	Function
1 White	Supply voltage ground
2 Brown	Positive supply voltage (12-24 V)
3 Green	Modbus® RS-485 A (+)
4 Yellow	Modbus® RS-485 B (-)
5 Grey	External sensor A
6 Pink	External sensor B
7 Blue	Heating voltage ground
8 Red	Positive heating voltage

The cable shielding shall be connected to earth in the electrical cabinet



- Only approved and tested appliances (conductors, risers etc.) should be used to install the device on the mast.
- All relevant regulations for working at this height must be observed.
- The mast must be sized and anchored appropriately.
- The mast must be earthed in accordance with regulations.
- The corresponding safety regulations for working at the installation site must be observed.



The yellow protective cap must be removed before plugging in the equipment.

If the equipment is not connected correctly

- It may not function
- It may be permanently damaged
- The possibility of an electrical shock may exist

The supply voltage and the heating voltage are protected against polarity reversal.

If the heating is operated on 12 VDC, account must be taken of the functional restrictions in winter operation. A heating voltage of 24 VDC is recommended to guarantee full heating duty.

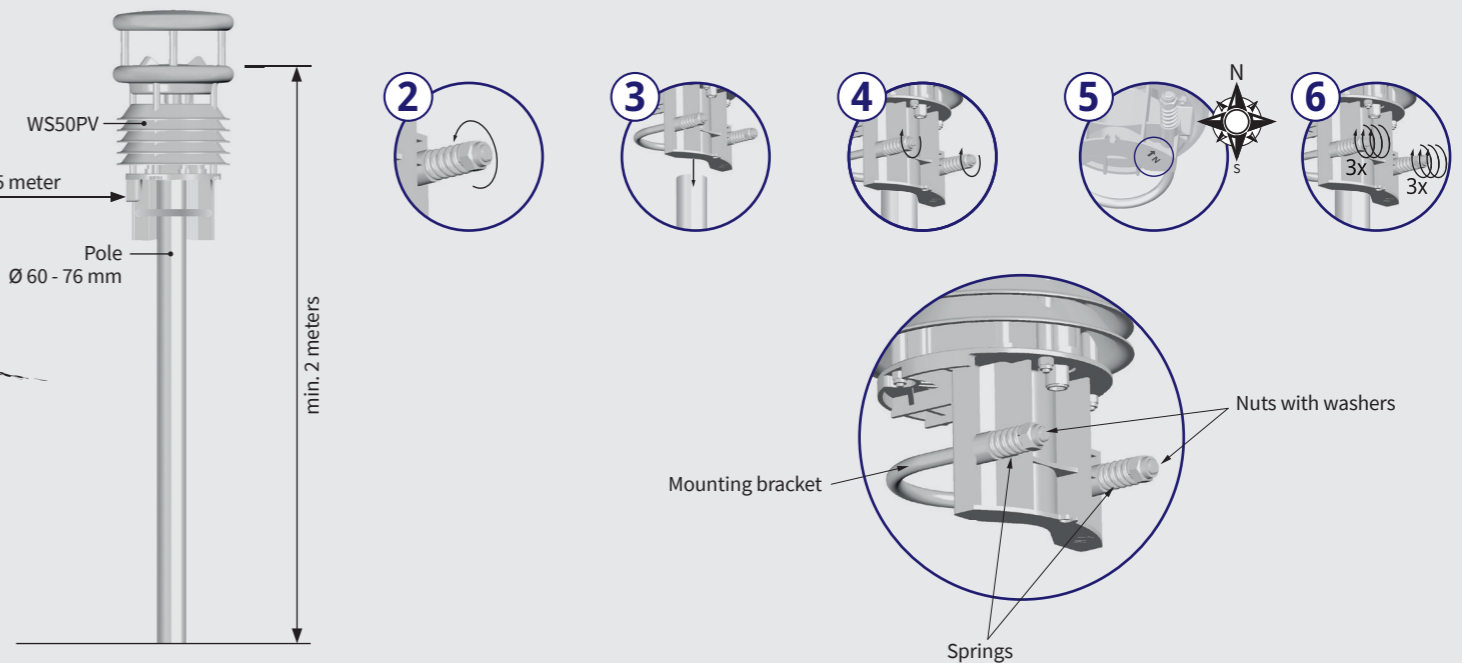

RS-485 interface	
Modbus® protocol	RTU
Modbus® default address	1
Modbus® default configuration	8E1, 19200 baud
Technical data	
Supply voltage	24 VDC ±10 % 12 VDC ±10 % (*)
Power consumption	±3.5 W
Protection class	III (SELV)
Protection type	IP66
Storage conditions	-50 °C ... 70 °C and 0 % RH ... 100 % RH
Operating conditions	-50 °C ... 60 °C and 0 % RH ... 100 % RH

(*) If heating is operating at 12 VDC, functional restrictions may occur during winter season

- ① Ensure unobstructed surroundings ⁽¹⁾
- ② Loosen nuts
- ③ Push the sensor onto the top of the mast from above ⁽²⁾
- ④ Tighten the nuts evenly until contact is made with the springs but the sensor can still be moved easily
- ⑤ Align the sensor to the North ⁽³⁾
- ⑥ Tighten both nuts with 3 revolutions

⁽¹⁾ Buildings, bridges, embankments and trees may corrupt the wind measurement. Equally, passing traffic may cause gusts which may influence the wind measurement.

⁽²⁾ For accurate compass readings, an aluminium mast is recommended.

⁽³⁾ As the magnetic North Pole indicated by the compass differs from the Geographic North Pole, account must be taken of the declination (variation) at the location when aligning the sensor. Depending on the location, the variation can be more than 15° (in North America for example). In Central Europe the variation can be largely ignored at present (< 3°).

Configuration details can be found in the Instruction Manual - Modbus® Only. Please refer to <https://www.otthydromet.com/en/Ott/p-kippzonen-ws50pv-compact-all-in-one-weather-sensor/8373.PV#resources> for more details or scan the QR code.



Parameter	Min.	Max.	Unit
Air temperature	-40.0	60.0	°C
Dewpoint temperature	-40.0	60.0	°C
Relative humidity	0	100.0	%
Air pressure	500	1100	hPa
Wind speed	0	50.0	m/s
Wind direction	0	359	°
Precipitation volume ⁽¹⁾	0	∞	mm
Precipitation intensity ⁽¹⁾	0	144	mm/h

⁽¹⁾ Requires additional accessories